

19



LE GOUVERNEMENT
DU GRAND-DUCHÉ DE LUXEMBOURG
Ministère de l'Économie

11

N° de publication :

LU100373

12

BREVET D'INVENTION**B1**

21

N° de dépôt: LU100373

51

Int. Cl.:
C21B 7/16

22

Date de dépôt: 18/08/2017

30

Priorité:

72

Inventeur(s):
THINNES Claude – 8284 Kehlen (Luxembourg)

43

Date de mise à disposition du public: 26/03/2019

74

Mandataire(s):
OFFICE FREYLINGER S.A. –
8001 STRASSEN (Luxembourg)

47

Date de délivrance: 26/03/2019

73

Titulaire(s):
Paul Wurth S.A. – 1122 Luxembourg (Luxembourg)

54

Extraction Device for a Tuyere Part.

57

Abstract: Extraction device for extracting a tuyere part, in particular a tuyere or a tuyere cooler, from a shaft furnace, the device comprising a supporting frame with positioning elements configured to position the device against a furnace wall. The device also comprises a carriage supported by the supporting frame. The carriage is movable in a direction radial to the furnace wall. The device further comprises an extraction rod having a first end attached to the carriage and a second end for connecting to the tuyere part, wherein the first end of the extraction rod comprises a stopper. The device also comprises a percussion system acting on the stopper of the extraction rod in a direction away from the furnace wall. The device comprises a pretensioning mechanism on the supporting frame. The pretensioning mechanism is configured to apply a load to the carriage, in a direction away from the furnace wall. (Fig. 2) LU100373

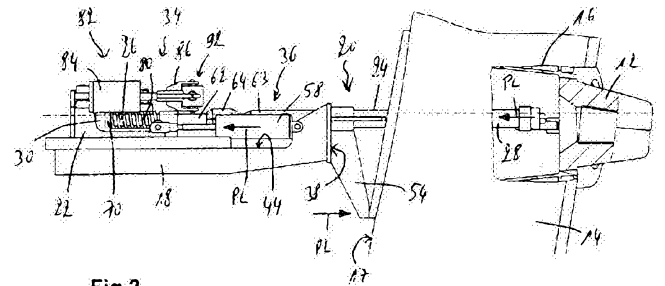

Fig.2

Extraction Device for a Tuyere Part

Technical field

[0001] The invention relates in general to removal devices for components of a gas injection system or tuyere parts in a blast furnace. The invention relates in particular to an extraction device for extracting a tuyere or a tuyere cooler from a blast furnace wall.

Background of the Invention

[0002] The maintenance work carried out during the shutdown of a blast furnace generally comprises changing tuyere parts. A tuyere comprises a nozzle through which gases are blown into the furnace. Modern blast furnaces commonly comprise more than 20 such tuyeres all around the furnace wall. The tuyeres are usually inserted into a tuyere cooler comprising a circuit for a cooling fluid. Tuyere and tuyere cooler are tightly pressed into an opening of the furnace wall.

[0003] Because of the very harsh conditions in the tuyere breast, the tuyere and often the tuyere cooler can be heavily damaged and may require replacing. The tuyere parts are often burnt or deformed, impeding the normal functioning of the furnace. Their damage may also provoke gas or water leakages outside of the furnace with high risks for the health and safety of the workers around the furnace.

[0004] The lifetime of a tuyere varies from several days to several months, which demands recurrent maintenance operation in relatively short intervals of time. In addition, tuyere parts are metal pieces weighting about 100 kg to 1000 kg, making their manual replacement a complicated task. Development of solutions for quicker and safer replacement of the tuyere parts in a blast furnace is hence important in the development of blast furnaces itself.

[0005] Solutions have been developed to mechanize and simplify the removal of a tuyere part. Most of them involve either a pulling mechanism or a hammer. Amongst the solutions known in the art, DE 1583205 discloses an apparatus comprising a percussion hammer installed on a trolley with an adjustable height. The trolley is fixed to the furnace wall with bolts. The hammer is provided with gripping means in order to engage with the tip of the tuyere. The hammer may be a regular electrical hammer.

[0006] Another solution is disclosed in EP 0443126, wherein an apparatus for mounting and dismantling a tuyere from a blast furnace comprises a hydraulic piston connected to a shaft. The shaft is provided with a handling element connected to the tuyere. The piston is configured to move the shaft in two directions for either inserting the tuyere into the furnace or removing the tuyere from the furnace.

[0007] Further, WO 2012177964 also discloses an apparatus for removing a tuyere from a blast furnace. The apparatus is adapted to be carried by a boom of a small excavator vehicle. The apparatus comprises a hammer activated by the operator of the vehicle. The hammer is also equipped with component handling means for pulling on the tuyere.

[0008] All the solutions of the state of the art share the same disadvantages. They imply heavy installation systems with numerous steps required to set and unset them, thereby slowing down the maintenance operation. They also need to be operated by an operator that will have to stay close to the machine. The operator is consequently exposed to eventual toxic gases released from the furnace.

[0009] In addition, when extracting a tuyere part, the fitting between the tuyere part and its holder is often jammed by material from inside the furnace, or just because of the deteriorated state of the parts. The traction force of state of the art pullers is generally not sufficient to extract the tuyere or tuyere cooler out of its conical seat. Even percussion hammers providing percussion power of up to 500 J may not solve this problem. As a result, the tuyere parts often have to be removed manually under risky conditions for health and safety.

Object of the invention

[0010] It is therefore desirable to provide an improved solution for removing tuyere parts from a blast furnace wall. More particularly, it is an object of the invention to provide an improved extraction device with higher extraction strength and better usability.

General Description of the Invention

[0011] The invention overcomes the above discussed deficiencies and disadvantages by providing an extraction device for extracting a tuyere part, in particular a tuyere or a tuyere cooler, from a shaft furnace, the device comprising a supporting frame with positioning elements configured to position the device against a furnace wall. The invention is particularly advantageous when used to remove a jammed part of the tuyere installation. The device also comprises a carriage supported by the supporting frame. The carriage is movable in a direction radial to the furnace wall. The furnace wall is commonly a circular wall so the carriage moves in a direction perpendicular to the wall. The device further comprises an extraction rod having a first end attached to the carriage and a second end for connecting to the tuyere part, wherein the first end of the extraction rod comprises a stopper. The device also comprises a percussion system acting on the stopper of the extraction rod in a direction away from the furnace wall, or a direction radial to the furnace wall with an orientation away from the wall. The device comprises a pretensioning mechanism on the supporting frame. The pretensioning mechanism is configured to apply a load to the carriage, in a direction away from the furnace wall.

[0012] The pretensioning mechanism pushes the carriage away from the furnace wall. As the extraction rod is attached to the carriage, the extraction rod is pushed away from the furnace wall together with the carriage. The force applied to the extraction rod by the pretensioning mechanism is further transmitted to the tuyere part. This force may, in some cases, be sufficient to move the tuyere part out of the wall. If however, the tuyere part cannot be removed from the furnace wall, the pretensioning mechanism maintains the pretensioning force, while the percussion system is used to provide further force.

[0013] Indeed, the extraction device has two mechanisms configured to provide mechanical forces in order to move the tuyere part out of the furnace wall: the pretensioning mechanism, and the percussion system. The combination of the forces provided by these two mechanisms provides a greater extraction force than prior art extraction devices.

[0014] An advantage of the invention is that the extraction device does not require any complex mechanical components. All the elements of the extraction

device may be connected together through common mechanical connections, like bolts or screws. The extraction device is thus very easy to maintain and repair. The invention helps reducing the maintenance time and the down time of the shaft furnace.

[0015] Moreover, the elements may be quickly replaced in order to adapt the device to a different tuyere part, or to modify the performances of the extraction device when more or less extraction power is required. The extraction device brings flexibility to the tuyere part removal process.

[0016] The extraction device according to the invention may be moved by a fork lift, but is light enough to be moved using a hand pallet truck.

[0017] Advantageously, the percussion system comprises: a striker configured to abut against the stopper of the extraction rod; at least one spring connected between the striker and the carriage; a loading mechanism; and a release mechanism. The at least one spring is configured to bias the striker against the stopper. The loading mechanism is configured to move the striker against the bias of the spring. The release mechanism is configured to engage and disengage the striker with/from the loading mechanism. During the loading phase, the release mechanism is engaged with the striker thereby building up energy in the spring. Upon activation of the release mechanism, the striker is disengaged from the loading mechanism and the buildup of the energy in the spring is suddenly released, allowing the striker to rapidly move towards the stopper of the extraction rod. As the striker hits the stopper, a sudden force is exerted on the extraction rod, which helps the extraction of the tuyere part.

[0018] The percussion system may have a hammering function. The loading and release mechanism may be operated alternately to throw the striker against the stopper of the extraction rod. These operations may be repeated as many times as necessary until the tuyere part is extracted from the furnace wall. The release mechanism using the reaction of the spring provides fast acceleration and efficient percussion effect. The loading and release operations may be operated with a predetermined frequency in order to achieve a vibrating effect of the tuyere part inside the furnace wall, which may help extraction of the tuyere part.

[0019] The striker may be a cylinder coaxially arranged around the extraction rod. Such a stopper may e.g. have a circular or square base. Other shapers are however also possible. Preferably, the stopper is also a cylinder. In these embodiments, the striker hits the stopper providing a balanced distribution of the forces acting on the end of the extraction rod. The extraction rod is always pushed in the same straight direction, thereby limiting uncontrolled vibrations and potential damage to the extraction device. These embodiments are also advantageous to provide better stability of the connection between the rod and the tuyere part.

[0020] Advantageously, the loading mechanism comprises at least one loading actuator. The loading actuator may be a pneumatic actuator. A pneumatic actuator is cheaper, more secure and easier to maintain than for instance a hydraulic actuator.

[0021] In preferred embodiments, the release mechanism comprises a hook adapted to engage or disengage the striker. The hook is a simple and reliable solution to quickly connect and disconnect the loading mechanism with/from the striker. It is also easy to repair.

[0022] Preferably the hook engages with a radial protrusion on the striker. This solution is again advantageous for its mechanical simplicity, providing quick and easy maintenance.

[0023] The hook is advantageously operated by a release actuator. The release actuator is preferably a pneumatic actuator. A pneumatic actuator is sufficiently reliable with the advantages described above.

[0024] In preferred embodiments, the pretensioning mechanism comprises at least one pretensioning actuator, which may be a pneumatic actuator. As described above, a pneumatic actuator has numerous advantages. In addition, it is possible to use more than one actuator in order to provide higher pretensioning mechanical forces.

[0025] Advantageously, the impact power of the percussion system on the extraction rod is between 1000 J and 1500 J. The impact power results from a combination of the forces applied the pretensioning mechanism and the percussion system. This impact power is superior to the power obtained using state of the art extraction devices and enables the extraction device to extract a

tuyere part from a furnace wall even in cases where the tuyere part is heavily jammed inside the wall.

[0026] The extraction device may be remotely controlled. There is no action that requires the proximity of an operator once the extraction device is installed against the furnace wall. This reduces health and safety risks for the operator during the extraction of the tuyere part.

[0027] In embodiments, the second end of the extraction rod comprises an engagement tool for engaging the tuyere part. The engagement tool may be an exchangeable tool improving the flexibility of the device. The extraction tool may be connected to any surface of the tuyere part or to a complementary part that is specifically created during the design of the tuyere part.

[0028] It is another object of the invention to provide a method for extracting a tuyere part, in particular a tuyere or a tuyere cooler, from a shaft furnace. The method comprises the steps of:

- providing an extraction device as described above;
- positioning the extraction device against the furnace wall;
- connecting the extraction rod to the tuyere part;
- operating the pretensioning mechanism to apply a pretensioning force to the tuyere part;
- operating the percussion system in order to remove the tuyere part.

[0029] The method retains all the advantages of the extraction device of the invention. The extraction of the tuyere part is performed quickly and does not require the assistance of an operator proximate to the extraction device.

[0030] In embodiments, the method is applied using an extraction device comprising a striker; at least one spring; a loading mechanism; and a release mechanism as described above. In these embodiments, the step of operating the percussion system comprises the steps of:

- operating the loading mechanism into an engaging position, wherein the release mechanism may engage the striker with the loading mechanism;
- operating the release mechanism into a closed position, wherein the striker engages with the loading mechanism;

- operating the loading mechanism into a release position, wherein the striker is away from the stopper;
- operating the release mechanism into an open position, wherein the striker disengages from the loading mechanism.

[0031] If necessary, the step of operating the percussion system may be repeated several times until the tuyere part is detached from the furnace wall and may be removed.

Brief Description of the Drawings

[0032] Further details and advantages of the present invention will be apparent from the following detailed description of not limiting embodiments with reference to the attached drawing, wherein:

Fig.1 is a perspective view of an embodiment of an extraction device according to the invention;

Fig.2 is a cross-sectional side view of the extraction device of Fig. 1 in a first operational step;

Fig.3 is a cross-sectional top view of the extraction device of Fig. 1 in a first operational step;

Fig.4 is a cross-sectional top view of the extraction device of Fig. 1 in a second operational step;

Fig.5 is a cross-sectional top view of the extraction device of Fig. 1 in a third operational step; and

Fig.6 is a cross-sectional top view of the extraction device of Fig. 1 in a fourth operational step.

Description of Preferred Embodiments

[0033] An extraction device 10 according to a preferred embodiment of the invention is shown in Figs 1 to 3. In a blast furnace, a number of tuyeres 12 are generally located inside the furnace wall 14 in order to feed hot gas into the furnace. In order to remove the tuyere 12, it is necessary to first remove the pipe portions, not shown, that connect to the tuyere 12. These operations are not part

of the context of the invention. We will here consider that the tuyere is already accessible and that other pipe portions have been preliminarily removed.

[0034] The extraction device 10 itself will be described by referring simultaneously to Figs 1 to 3. Figs 3 to 6 are thereafter used to show operational steps of the extraction device 10 in use.

[0035] A tuyere 12 is arranged in a furnace wall 14, usually within a tuyere cooler 16. Both the tuyere 12 and tuyere cooler 16 are securely wedged in a conical seat narrowing in the direction of the interior of the furnace.

[0036] In operation, the extraction device 10 is positioned against an exterior surface 17 of the furnace wall 14 so as to access the tuyere 12 to be removed. While, for the sake of conciseness, the present description is limited to the removal of a tuyere 12, it should be noted that the extraction device equally adapted to also remove the tuyere cooler 16 from the furnace wall 14, generally in a separate step.

[0037] The extraction device 10 comprises a supporting frame 18 with positioning elements 20 for contacting the exterior surface 17 of the furnace wall 14.

[0038] The extraction device 10 also comprises a carriage 22 supported by the supporting frame 18. The carriage 22 is movable in a direction radial to the furnace wall 14. The carriage may comprise wheels, not shown, in order to roll over the supporting frame 18. Alternatively, the carriage 22 may be glidingly arranged on the supporting frame 18.

[0039] The extraction device 10 comprises an extraction rod 24, which has a first end 26 attached to the carriage 22 and a second end 28 configured for connecting to the tuyere 12. The first end 26 of the extraction rod 24 comprises a stopper 30, while second end 28 of the extraction rod 24 comprises an engagement tool 32 gripping the tuyere 12 to be removed.

[0040] The extraction device 10 further comprises a percussion system 34, acting on the stopper 30 of the extraction rod 24 in a direction away from the furnace wall 14.

[0041] Finally, the extraction device 10 comprises a pretensioning mechanism 36 on the supporting frame 18. The pretensioning mechanism 36 is configured to

apply a mechanical load to the carriage 22, in a direction away from the furnace wall 14.

[0042] The supporting frame 18 may be a metallic casing that is adapted to support the other elements of the device 10. The supporting frame 18 comprises a vertical front face 38 oriented in direction of the furnace wall 14, the front face 38 having the positioning elements 20 connected thereto, and a top face 44 carrying the carriage 22.

[0043] The top face 44 of the supporting frame 18 comprises an essentially horizontal plane on which the carriage 22 is movably arranged. The carriage 22 may comprise wheels (not shown) which engage with rails (not shown) arranged on the top face 44 of the supporting frame 18.

[0044] Fixed to the front face 38 of the supporting frame 18, the positioning element 20 comprises three metallic feet 54 adapted to contact the furnace wall 14. In the embodiments shown, when the device 10 is positioned on the furnace wall 14, two of the metallic feet 54 may be on a same horizontal plan on each side of the device 10 and the third one may be below the others, creating a T configuration. The positioning element 20 impedes a rotation or translation movement of the device 10 in operation. Other configurations of the metallic feet may be envisaged. Indeed, the three metallic feet may be equidistantly arranged. More than three feet may be provided.

[0045] The positioning element 20 is preferably removably fixed to the front face 38, e.g. by screws or similar means. The positioning element 20 may then be replaced to adapt to the configuration of another furnace wall, making the device customizable.

[0046] In the embodiment shown, the pretensioning mechanism 36 comprises two pretensioning actuators 58. The pretensioning actuators 58 are two pneumatic pistons fixed between the supporting frame 18 and the carriage 22 such that, when the pretensioning actuators 58 are extended, the carriage 22 is pushed away from the furnace wall 14. Inversely, a retraction of the pretensioning actuators 58 pulls the carriage 22 in the direction of the furnace wall 14.

[0047] The connection between the pretensioning actuators 58 and the supporting frame 18, as well as the connection between the pretensioning actuators 58 and the carriage 22 may be formed by any suitable means.

[0048] In preferred embodiments, the pretensioning actuators 58 are dimensioned to apply a pushing mechanical load on the carriage between 1.2 and 2.0 to.

[0049] The carriage 22 has the first end 26 of the extraction rod 24 connected thereto. Thus, as the pretensioning actuators 58 exert a force on the carriage 22 in a direction away from the furnace wall 14, the same force is also exerted on the extraction rod 24 connected with its second end to the tuyere 12. Consequently, the force exerted on the carriage 22 is also transferred, via the extraction rod 24, to the tuyere 12.

[0050] The extraction rod 24 may be removably connected to the carriage 22, e.g. by means of screws, thereby allowing for the extraction rod 24 to be exchangeable. Alternatively, the extraction rod 24 may comprise a first rod portion 62 connected to the carriage 22 and a second rod portion 63 removably connected to the first rod portion 62 via a connector portion 64. Thus, the second rod portion 63 is exchangeable. The connector portion 64 may connect the second rod portion 63 to the first rod portion 62 by means of e.g. a screw fit or bayonet fit. Such a connector portion 64 allows to the second rod portion 63 to be quickly exchanged. This may be of importance if a second rod portion 63 or the engagement tool 32 has become damaged. Also, it may be replaced with a second rod portion 63 having a different engagement tool, better adapted for removing a different tuyere part such as e.g. a tuyere cooler 16.

[0051] As explained above, the second end 28 of the extraction rod 24 comprises an engagement tool 32 with a plurality of engagement arms 65. The engagement arms 65 are designed to be inserted in a complementary arm receiver 67 of the tuyere 12. This way, a movement of the extraction rod 24 in a direction away from the furnace wall 14 provokes a movement of the tuyere 12 in the same direction.

[0052] The carriage 22 further carries the percussion system 34 comprising striker 70 configured to abut against the stopper 30 of the extraction rod 24. The percussion system 34 comprises a loading mechanism 82 configured to move the

striker 70 against the bias of preferably at least two springs 80 away from the stopper 30.

[0053] To this effect, the loading mechanism 82 comprises two loading actuators 84. The loading actuators 84 may be pneumatic pistons; hydraulic pistons or any other actuator may however also be used.

[0054] The loading actuators 84 are operatively connected between the carriage 22 and a common loading bar 86.

[0055] In preferred embodiments, the loading actuators 84 are dimensioned to exert a pushing load on the loading bar 86 between 2.0 and 3.5 to.

[0056] The striker 70 is preferably formed by a striking cylinder coaxially arranged around the extraction rod 24. The striker 70 is configured to translate along the extraction rod 24. The striker 70 may for example weigh around 40 to 50 kg.

[0057] Two springs 80 are mounted between the striker 70 and the carriage 22. The springs 80 are preferably heavy duty helical springs. The springs 80 are configured to bias the striker 70 against the stopper 30.

[0058] In preferred embodiments, the springs are dimensioned to apply a pushing mechanical load on the striker between 2.0 and 3.5 to.

[0059] The percussion system 34 further comprises a release mechanism 92 configured to engage and disengage the striker 70 with/from the loading mechanism 82.

[0060] The release mechanism 92 is mounted on the loading bar 86 of the loading mechanism 82 and comprises a hook 94 and a release actuator 96. The hook 94 is adapted to engage or disengage with a radial protrusion 100 on the striker 70. The hook 94 projects on one side of the loading bar 86 with a shape configured to engage with the protrusion 100 so as to block a translation of the striker 70 along the extraction rod 24 relative to the hook 94. The hook 94 also projects on the other side of the loading bar 86 where it is connected to the release actuator 96.

[0061] The release actuator 96 may be a pneumatic actuator, and more particularly a pneumatic piston.

[0062] The release actuator 96 is connected the hook 94 such that the translational movement of the piston 96 rotates the hook 96 like a lever in order to engage or disengage with/from the striker 70.

[0063] In the following description, the functioning of the extraction device 10 will be explained with regard to Figs 3 to 6.

[0064] In order to remove the tuyere 12 from the tuyere cooler 16, the extraction device 10 is first brought in front of the tuyere 12. The extraction device 10 may have an estimated total weight of about 1300 kg and may be carried on a forklift or a hand pallet truck to be easily manipulated in the surroundings of the furnace. Once the extraction device 10 is in front of the conical seat, the extraction rod 24 is inserted in the furnace wall 14. During that step, the pistons 58 of the pretensioning mechanism 36 are in a retracted position.

[0065] The engagement arms 65 of the engagement tool 32 are connected with a respective arm receiver 67 of the tuyere 12. The step of connecting the engagement tool to the tuyere may comprise more intermediary manoeuvres depending on the configuration of the engagement tool 32.

[0066] Fig. 3 shows the extraction device 10 in a first operational step, wherein the pistons 58 of the pretensioning mechanism 36 are in extended position and the three feet 54 of the positioning element 20 are against the furnace wall 14 with the extraction rod 24 engaged in the tuyere 12. Control of the extraction device 10 is achieved by operating the pneumatic actuators mentioned above. The extraction device 10 may comprise a controller in order to be remotely operated and no operator is required around the extraction device 10, reducing the risks for human health and safety.

[0067] A pretensioning force is then applied by the pretensioning actuators 58 pushing the carriage 22 away from the furnace wall 14. Fig. 3 shows arrows PL representing the pretensioning forces applied on the carriage 22, the tuyere 12, and the reaction of the metallic feet 54 against the furnace wall 14. We note that the two pretensioning actuators 58 are operated simultaneously applying a total force of 1.2 - 2.0 to against the tuyere 12.

[0068] In the figures, all arrows representing forces are only schematically represented to improve the understanding of the functioning of the extraction device 10.

[0069] The resulting pretensioning force PL may in some cases be sufficient to remove the tuyere 12 from the furnace wall. Experience as shown however that, due to the state of the tuyere and the harsh conditions inside the furnace, the fitting between the tuyere 12 and the tuyere cooler 16 is often jammed and the force applied by the pretensioning mechanism alone is not sufficient to extract the tuyere 12.

[0070] In the following steps, shown in Figs 4 to 6, the percussion system 34 is operated. At the beginning of this step, the loading mechanism 82 is in an engaging position.

[0071] First, as shown in Fig. 4, the loading mechanism 82 is operated. The percussion system 34 is operated with the release mechanism 92 in a closed position, wherein the hook 94 engages the radial protrusion 100 of the striker 70.

[0072] The loading mechanism 82 is controlled to extend the loading actuators 84 and thereby push the loading bar 86 away from the stopper 30. The loading forces are represented by arrows L. As the release mechanism 92 is in the closed position, the striker 70 is driven away from the stopper 30, against the bias of the springs 80. Here again, the two loading actuators 84 are operated simultaneously.

[0073] Once the loading mechanism 82 has reached its release position, which may e.g. be defined by the maximum extension of the loading actuators 84 or the maximum allowed compression of the springs 80 by mechanical stopper, operation of the loading mechanism 82 is stopped.

[0074] The release mechanism 92 is now operated by activating the release actuator 96 which moves the hook 94 into an open position so as to disengage from the radial protrusion 100 of the striker 70. The hook 94 disengages from the radial protrusion 100 and releases the connection between the release mechanism 92 and the striker 70. The springs 80 are allowed to move back to their resting position, thereby thrusting the striker 70 towards the stopper 30 as shown in Fig.5.

[0075] When the striker 70 hits the stopper 30 as shown in Fig. 6, a percussion force P is transmitted from the stopper 30 to the extraction rod 24 and via the

engagement tool 32, to the tuyere 12. The percussion creates a sudden and instantaneous increase in the pulling force applied to the tuyere 12 by the combination of the pretensioning force and the percussion force, represented by a arrows PL+P in Fig. 6.

[0076] The resulting combination force PL+P provokes a small movement of the tuyere 12 in the direction of the extraction device 10. As the pretensioning force PL is continuously applied by the pretensioning pistons 58, if the tuyere 12 is freed from the tuyere cooler 16, the pretensioning pistons 58 may continue to move the carriage 22 away from the furnace wall 14, thus extracting the tuyere 12. In case the tuyere 12 remains wedged in the tuyere cooler 16, the percussion system 34 may be operated again.

[0077] In order to operate the percussion system 34 again, the loading actuators 84 of the loading mechanism 82 are retracted back to the engaging position, bringing the hook 94 closer to the radial protrusion 100 of the striker 70. The release actuator 96 rotates the hook 94 in the opposite direction as above into the closed position. The hook 94 thus engages with the radial protrusion 100 of the striker 70. The device 10 is now in a similar configuration as shown in Fig. 3.

[0078] The steps of operating the percussion system 34 may be repeated as many times as necessary until the tuyere 12 is fully extracted from the tuyere cooler 16. The recurring percussion may also create a vibration effect applied after each successive release of the striker 70.

[0079] For example the frequency of the percussion may be about 8 hits per minute at an operating piston pressure of 4 bar(g), or 12 hits per minute at 6 bar(g).

[0080] Using the combination of the pretensioning mechanism 58 and the percussion system 34, the extraction device 10 achieves greater extraction forces to a tuyere or tuyere cooler than the solutions currently known in the art.

List of Reference Symbols

10	extraction device	58	pretensioning actuator
12	tuyere	62	first rod portion
14	furnace wall	63	second rod portion
16	tuyere cooler	64	connection portion
17	exterior surface	65	engagement arm
18	supporting frame	67	arm receiver
20	positioning elements	70	striker
22	carriage	80	springs
24	extraction rod	82	loading mechanism
26	first end	84	loading actuator
28	second end	86	loading bar
30	stopper	92	release mechanism
32	engagement tool	94	hook
34	percussion system	96	release actuator
36	pretensioning mechanism	100	radial protrusion
38	front face	PL	pretensioning force
44	top face	L	loading force
54	metallic feet	P	percussion force

P-PWU-767/LU

REVENDEICATIONS

1. Dispositif d'extraction pour extraire une partie de tuyère, en particulier une tuyère ou un refroidisseur de tuyère, d'un four à cuve, le dispositif comprenant :
 - 5 - un cadre support avec un élément de positionnement configuré pour positionner le dispositif d'extraction contre une paroi de four ;
 - un chariot supporté par le cadre support, ledit chariot étant mobile dans un sens radial par rapport à la paroi de four ;
 - une tige d'extraction ayant une première extrémité fixée au chariot et une deuxième extrémité pour se connecter à la partie de tuyère,
10 dans lequel la première extrémité de la tige d'extraction comprend une butée d'arrêt ; et
 - un système de percussion agissant sur la butée d'arrêt de la tige d'extraction dans un sens à l'opposé de la paroi de four ;
 - un mécanisme de prétension sur ledit cadre support, le mécanisme
15 de prétension étant configuré pour appliquer une charge au chariot, dans un sens à l'opposé de la paroi de four.

2. Dispositif d'extraction selon la revendication 1, dans lequel le système de
20 percussion est fixé au chariot.

3. Dispositif d'extraction selon la revendication 1 ou 2, dans lequel le système de percussion comprend :
 - un perceur, configuré pour buter contre la butée d'arrêt de la tige
d'extraction ;
 - 25 - au moins un ressort connecté entre le perceur et le chariot, l'au moins un ressort étant configuré pour pousser le perceur contre la butée d'arrêt ;

- un mécanisme de chargement configuré pour déplacer le percuteur à l'encontre de la poussée du ressort ; et
- un mécanisme de libération configuré pour engager et désengager le percuteur avec le/du mécanisme de chargement.

5

4. Dispositif d'extraction selon la revendication 3, dans lequel le percuteur est un cylindre agencé coaxialement autour de la tige d'extraction.
5. Dispositif d'extraction selon la revendication 3 ou 4, dans lequel le mécanisme de chargement comprend au moins un actionneur de chargement, ledit actionneur de chargement étant préférablement un actionneur pneumatique.
6. Dispositif d'extraction selon l'une quelconque des revendications 3 à 5, dans lequel le mécanisme de libération comprend un crochet adapté à engager ou désengager le percuteur.
7. Dispositif d'extraction selon la revendication 6, dans lequel le crochet s'engage avec une saillie radiale sur le percuteur.
8. Dispositif d'extraction selon la revendication 6 ou 7, dans lequel le crochet est opéré par un actionneur de libération, ledit actionneur de libération étant préférablement un actionneur pneumatique.
9. Dispositif d'extraction selon l'une quelconque des revendications précédentes, dans lequel le mécanisme de prétension comprend au moins un actionneur de prétension, ledit actionneur de prétension étant préférablement un actionneur pneumatique.
10. Dispositif d'extraction selon l'une quelconque des revendications précédentes, dans lequel la puissance d'impact du système de percussion sur la tige d'extraction est entre 1 000 J et 1 500 J.

11. Dispositif d'extraction selon l'une quelconque des revendications précédentes, dans lequel le dispositif d'extraction comprend un contrôleur afin de commander à distance le dispositif d'extraction.
- 5 12. Dispositif d'extraction selon l'une quelconque des revendications précédentes, dans lequel la deuxième extrémité de la tige d'extraction comprend un outil d'engagement pour engager la partie de tuyère.
- 10 13. Procédé pour extraire une partie de tuyère, en particulier une tuyère ou un refroidisseur de tuyère, d'un four à cuve, le procédé comprenant les étapes de :
- fourniture d'un dispositif d'extraction selon l'une quelconque des revendications précédentes ;
 - positionnement du dispositif d'extraction contre la paroi de four ;
 - 15 - connexion de la tige d'extraction à la partie de tuyère ;
 - utilisation du mécanisme de prétension pour appliquer une force de prétension à la partie de tuyère ;
 - utilisation du système de percussion afin de sortir la partie de tuyère.
- 20 14. Procédé selon la revendication 13, dans lequel l'étape d'utilisation du système de percussion comprend les étapes de :
- utilisation du mécanisme de chargement dans une position d'engagement, dans laquelle le mécanisme de libération peut engager le percuteur avec le mécanisme de chargement ;
 - 25 - utilisation du mécanisme de libération dans une position fermée, dans laquelle le percuteur s'engage avec le mécanisme de chargement ;
 - utilisation du mécanisme de chargement dans une position de libération, dans laquelle le percuteur est à l'écart de la butée d'arrêt ;
 - 30 - utilisation du mécanisme de libération dans une position ouverte, dans laquelle le percuteur se désengage du mécanisme de chargement.

15. Procédé selon la revendication 13 ou 14, dans lequel l'étape d'utilisation du système de percussion est répétée.

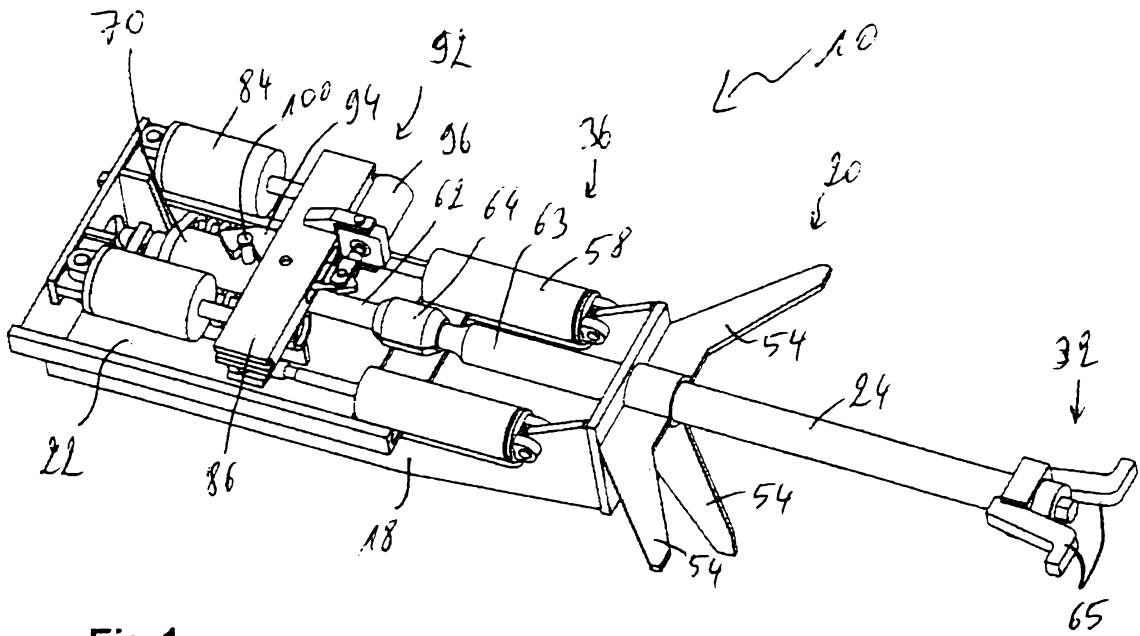

Fig. 1

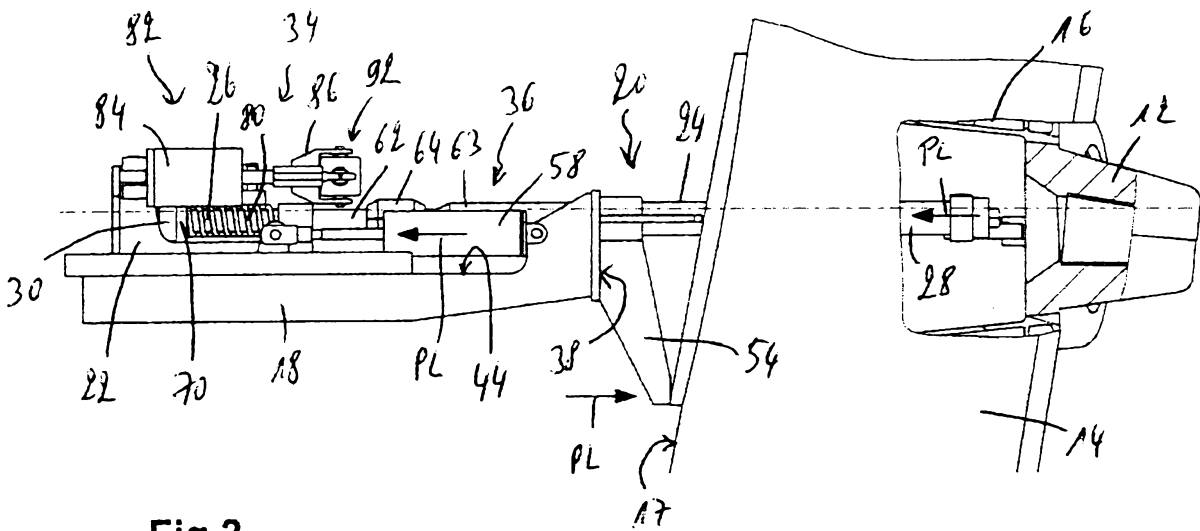

Fig. 2

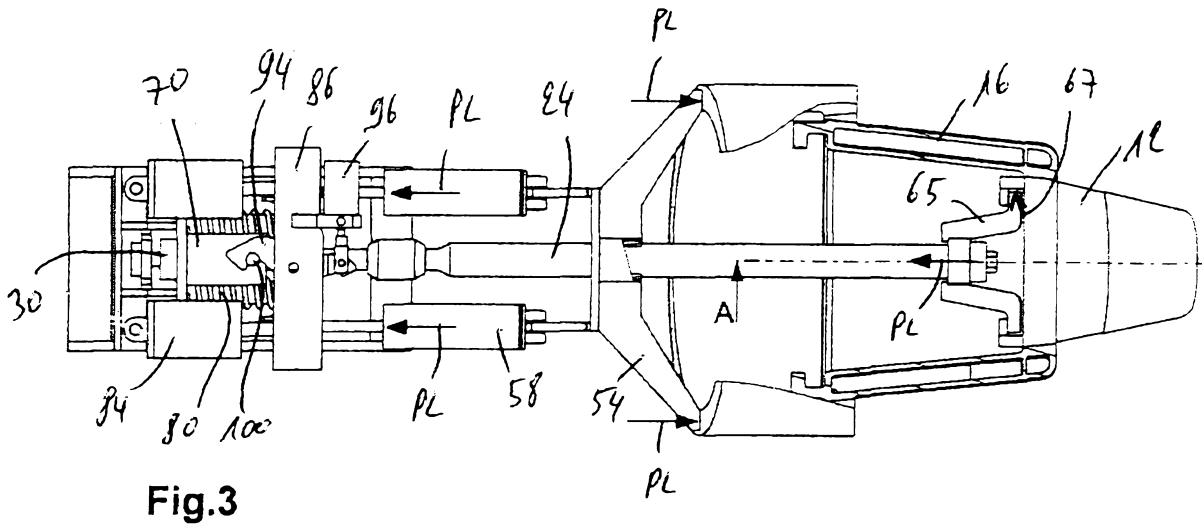

Fig.3

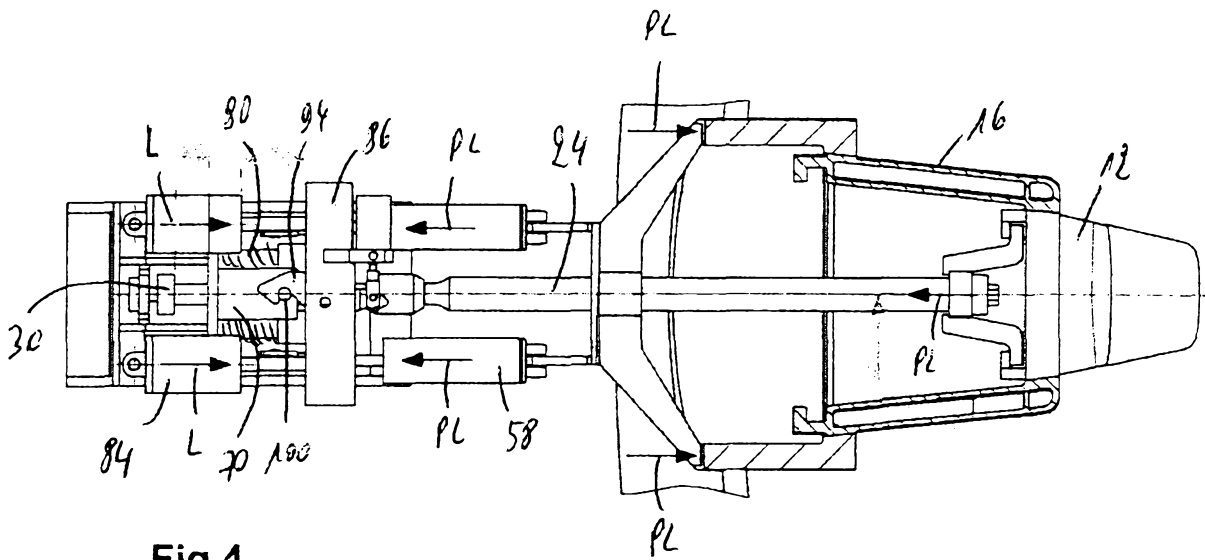

Fig.4

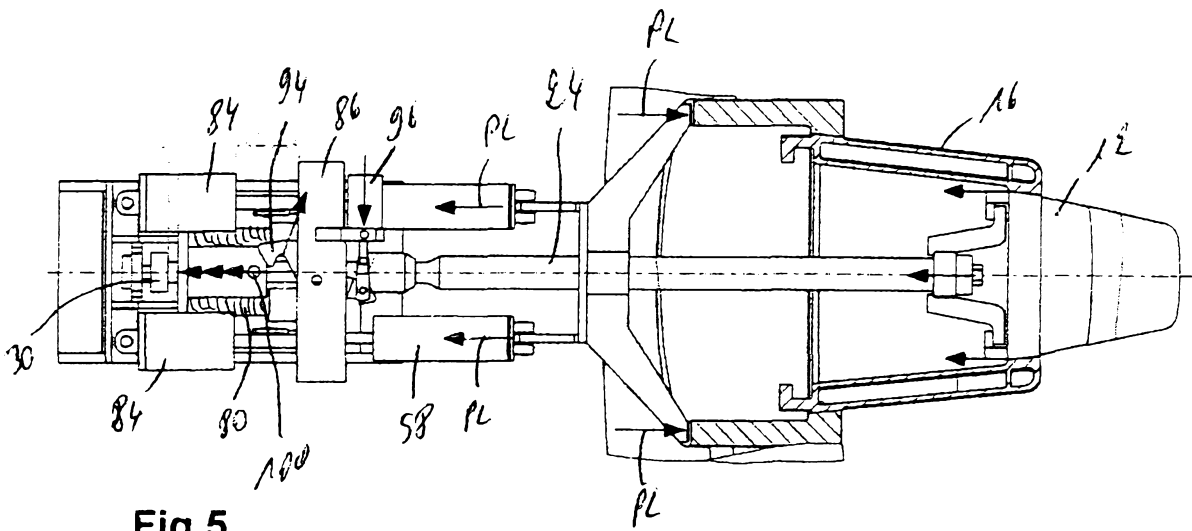

Fig. 5

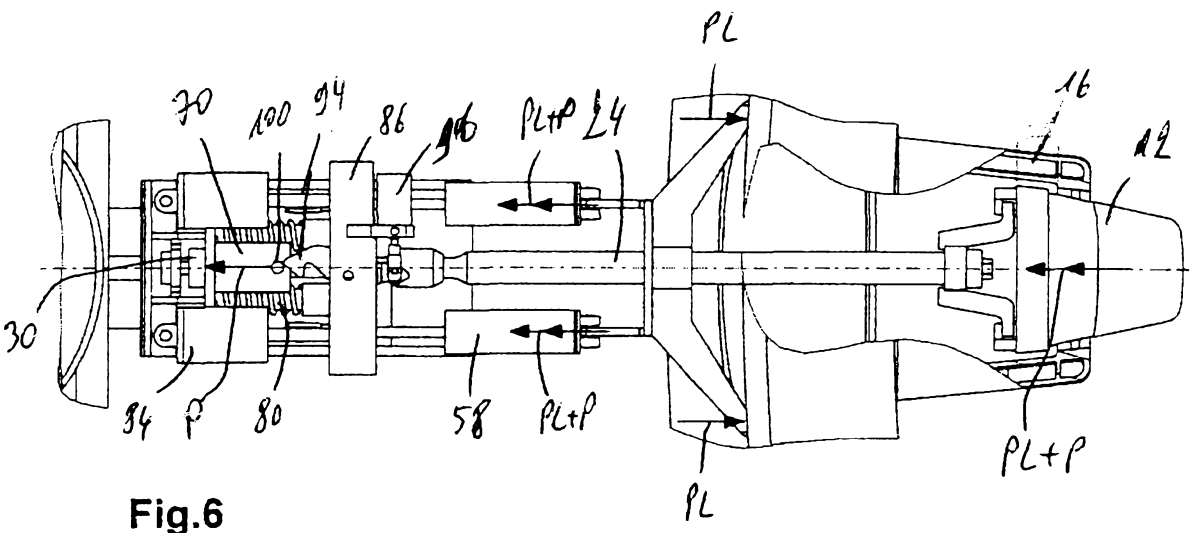

Fig. 6

Abstract

Extraction device for extracting a tuyere part, in particular a tuyere or a tuyere cooler, from a shaft furnace, the device comprising a supporting frame with positioning elements configured to position the device against a furnace wall. The device also
5 comprises a carriage supported by the supporting frame. The carriage is movable in a direction radial to the furnace wall. The device further comprises an extraction rod having a first end attached to the carriage and a second end for connecting to the tuyere part, wherein the first end of the extraction rod comprises a stopper. The device also comprises a percussion system acting on the stopper of the extraction
10 rod in a direction away from the furnace wall. The device comprises a pretensioning mechanism on the supporting frame. The pretensioning mechanism is configured to apply a load to the carriage, in a direction away from the furnace wall.

(Fig. 2)



SEARCH REPORT
in accordance with Article 35.1 a)
of the Luxembourg law on patents
dated 20 July 1992

LO 1751
LU 100373

DOCUMENTS CONSIDERED TO BE RELEVANT			
Category	Citation of document with indication, where appropriate, of relevant passages	Relevant to claim	CLASSIFICATION OF THE APPLICATION (IPC)
X	SU 1 289 886 A1 (VNI PK T I MEKH TRUDA V CHERNO [SU]) 15 February 1987 (1987-02-15) * abstract * * figures 1, 4 *	1-15	INV. C21B7/16
A	US 3 456 739 A (SAGAE MAKOTO) 22 July 1969 (1969-07-22) * figures 1,2 *	1-15	
			TECHNICAL FIELDS SEARCHED (IPC)
			C21B
The present search report has been drawn up for all claims			
		Date of completion of the search	Examiner
		25 January 2018	Gimeno-Fabra, Lluís
CATEGORY OF CITED DOCUMENTS			
X : particularly relevant if taken alone Y : particularly relevant if combined with another document of the same category A : technological background O : non-written disclosure P : intermediate document		T : theory or principle underlying the invention E : earlier patent document, but published on, or after the filing date D : document cited in the application L : document cited for other reasons & : member of the same patent family, corresponding document	

**ANNEX TO THE SEARCH REPORT
ON LUXEMBOURG PATENT APPLICATION NO.**

LO 1751
LU 100373

This annex lists the patent family members relating to the patent documents cited in the above-mentioned European search report.
The members are as contained in the European Patent Office EDP file on
The European Patent Office is in no way liable for these particulars which are merely given for the purpose of information.

25-01-2018

Patent document cited in search report		Publication date	Patent family member(s)	Publication date
SU 1289886	A1	15-02-1987	NONE	
US 3456739	A	22-07-1969	NONE	



WRITTEN OPINION

File No. LO1751	Filing date (day/month/year) 18.08.2017	Priority date (day/month/year)	Application No. LU100373
International Patent Classification (IPC) INV. C21B7/16			
Applicant Paul Wurth S.A.			

This report contains indications relating to the following items:

- Box No. I Basis of the opinion
- Box No. II Priority
- Box No. III Non-establishment of opinion with regard to novelty, inventive step and industrial applicability
- Box No. IV Lack of unity of invention
- Box No. V Reasoned statement with regard to novelty, inventive step or industrial applicability; citations and explanations supporting such statement
- Box No. VI Certain documents cited
- Box No. VII Certain defects in the application
- Box No. VIII Certain observations on the application

Form LU237A (Cover Sheet) (January 2007)	Examiner Gimeno-Fabra, Lluís
--	---------------------------------

WRITTEN OPINION

Application No.
LU100373

Box No. I Basis of the opinion

1. This opinion has been established on the basis of the latest set of claims filed before the start of the search.
2. With regard to any **nucleotide and/or amino acid sequence** disclosed in the application and necessary to the claimed invention, this opinion has been established on the basis of:
 - a. type of material:
 - a sequence listing
 - table(s) related to the sequence listing
 - b. format of material:
 - on paper
 - in electronic form
 - c. time of filing/furnishing:
 - contained in the application as filed.
 - filed together with the application in electronic form.
 - furnished subsequently.
3. In addition, in the case that more than one version or copy of a sequence listing and/or table relating thereto has been filed or furnished, the required statements that the information in the subsequent or additional copies is identical to that in the application as filed or does not go beyond the application as filed, as appropriate, were furnished.
4. Additional comments:

Box No. V Reasoned statement with regard to novelty, inventive step and industrial applicability; citations and explanations supporting such statement

1. Statement

Novelty	Yes: Claims	3-9, 13-15
	No: Claims	1, 2, 10-12
Inventive step	Yes: Claims	
	No: Claims	1-15
Industrial applicability	Yes: Claims	1-15
	No: Claims	

2. Citations and explanations

see separate sheet

WRITTEN OPINION

Application No.
LU100373

Box No. VII Certain defects in the application

The following defects in the form or contents of the application have been noted:

see separate sheet

Re Item V

Reasoned statement with regard to novelty, inventive step or industrial applicability; citations and explanations supporting such statement

Reference is made to the following document:

D1 SU 1 289 886 A1 (VNI PK T I MEKH TRUDA V CHERNO [SU]) 15
February 1987 (1987-02-15) EPODOC Abstract cited.

The present application does not meet the criteria of patentability, because the subject-matter of claim 1 is not new.

D1 discloses a tuyère replacement apparatus for extracting a tuyère from a shaft furnace body, wherein:

a supporting frame is positioned against the wall of the furnace (e.g. it is not a cart-based extractor but action-reaction type against the furnace wall),

a carriage (wherein the extractor is supported) is slidably placed on the supporting frame, moving longitudinally thereon and hence radially to the furnace,

an extraction rod comprising a stopper (16-20)

wherein a percussion system (abstract) acts on said stopper,

and mechanical pre-tensioning means configured to apply a load to the carriage in direction away from the furnace wall (see cylinders and operating handle, Fig. 4).

All of the technical features of claim 1 and corresponding method claim 13 are disclosed in D1. Said claims are therefore not novel. The same applies to claim 2 and 12 (see percussion means in Fig. 4 in combination with Abstract) and latches).

Claims 10 and 11 provide no technical apparatus features and are therefore not novel either.

The Division was hesitant in view of the inventive step of claim 3, as it does not appear that D1 discloses a spring. Taking into account that no precise technical effects are derivable from said construction means, the Division considers that Claims 3-9 and *mutatis mutandis* 13-15 refer to slight constructional changes the apparatus of claim 1 or process steps (such as the repetitions of the hammering process) which come within the scope of the customary practice followed by persons skilled in the art, especially as the advantages thus achieved can readily be foreseen. Consequently, the subject-matter said claims lacks an inventive step.

Re Item VII

Certain defects in the application

The applicant is requested to use reference signs in claims and briefly discuss D1 in the description, as its content seems highly relevant to the application.