

No. 640,388.

Patented Jan. 2, 1900.

H. G. KELLEY.
REINFORCED SWITCH POINT.

(Application filed Nov. 9, 1899.)

(No Model.)

2 Sheets—Sheet 2.

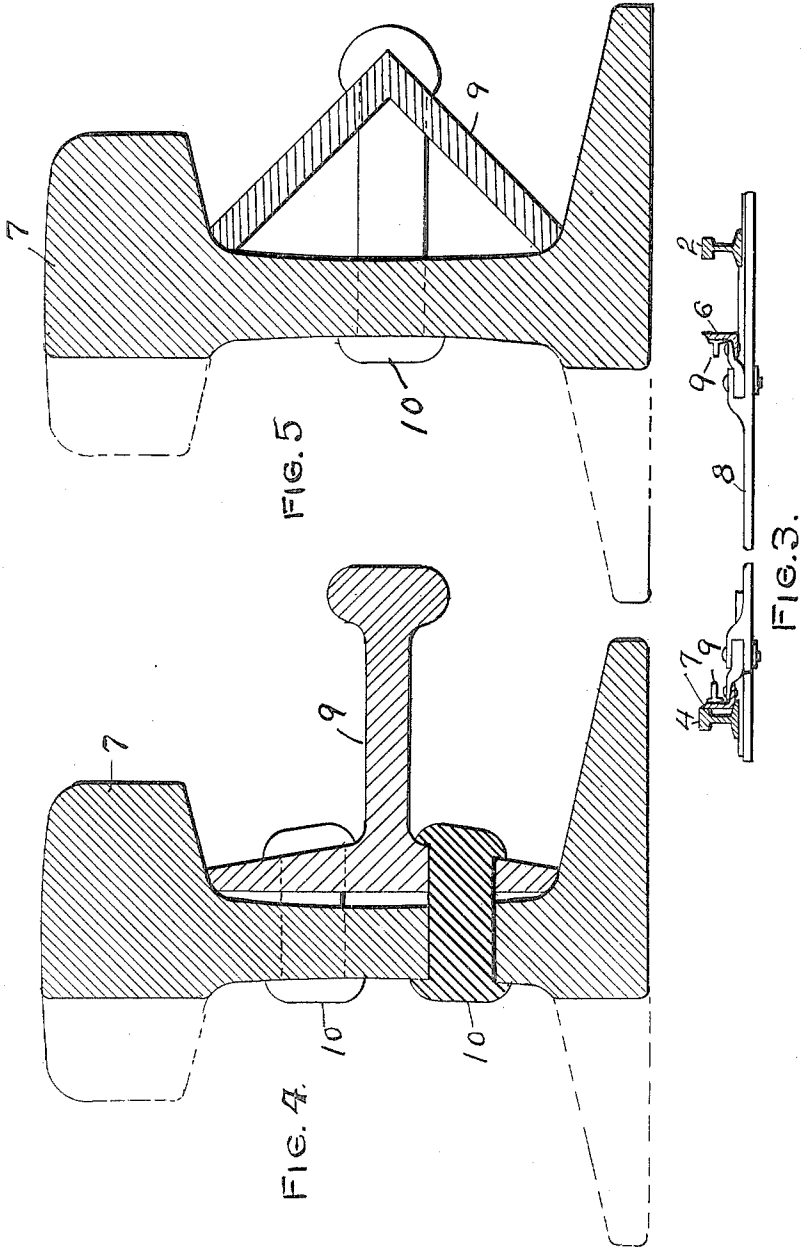

WITNESSES
E. J. Stause
Richard Paul

INVENTOR
HOWARD G. KELLEY
BY *Paulo Hawley*
HIS ATTORNEYS.

UNITED STATES PATENT OFFICE.

HOWARD G. KELLEY, OF MINNEAPOLIS, MINNESOTA.

REINFORCED SWITCH-POINT.

SPECIFICATION forming part of Letters Patent No. 640,388, dated January 2, 1900.

Application filed November 9, 1899. Serial No. 736,332. (No model.)

To all whom it may concern:

Be it known that I, HOWARD G. KELLEY, of the city of Minneapolis, county of Hennepin, State of Minnesota, have invented a new and Improved Reinforced Switch-Point, of which the following is a specification.

My invention relates to railroad-switches, and particularly to means for reinforcing or strengthening switch-points, whereby accidents from the breaking of points may be avoided.

The object of the invention is to strengthen the switch-point close to the end thereof from and before the point where strain or pressure is exerted thereon by the flange of the locomotive-driver or car-wheel in passing over the switch.

My invention consists generally in the combination, with the rail comprising the switch-point, of a lateral reinforcement upon the inner side of the rail; and the invention further consists in particular constructions and combinations of parts, all as hereinafter described, and particularly pointed out in the claims.

The invention will be more readily understood by reference to the accompanying drawings, forming part of this specification, and in which—

Figure 1 illustrates a railroad-switch embodying my invention. Fig. 2 is an enlarged section of the switch-point on the line *x x* of Fig. 1. Fig. 3 is a section of Fig. 1 on the line *y y*, slightly enlarged. Fig. 4 shows a modification of the reinforced rail. Fig. 5 illustrates a further modification thereof.

In the drawings, 2 and 3 represent the main rails of the track, and 4 represents the stock-rail leading to the side track. 5 is the other side-track rail. The switch-points 6 and 7 extend from the ends of the rails 5 and 3, respectively. These points are of the usual construction, with the exception of the reinforcements hereinafter defined and the further exception of the omission of the bridle-rods connecting the switch-points. The head-rod 8, which joins the free ends of the switch-points and which extends to the switch-stand, may be of any desired construction or type.

Various plans have been devised heretofore to hold together the pieces of a switch-point when broken, and these have in many in-

stances prevented wrecks, while in other instances wrecks have been occasioned by such looseness between the pieces of a broken point as to permit the derangement thereof, throwing the same into the flangeway of the wheels. A particular object, therefore, of this invention is not only to provide means to tie the switch-point at close distances, as provided for heretofore, but also to provide means that will certainly and surely hold the parts of a broken rail in line, so that the same cannot interfere with the wheels of the locomotive or cars, which will pass safely. To this end I attach to the side, preferably only the inner side, of the switch-point a long reinforcing rod or rail 9, extending close up to the points or toes of the tapered switch-rails. This reinforcement is secured by rivets 10, closely arranged and preferably staggered, the same passing through the web of the rail and drawing the reinforcing parts so closely to the rail that the same is, in effect, as strong as though integral therewith, while possessing the advantage of cheap manufacture and repair. The reinforcing part may be of any desired cross-section, so long as it effects lateral resistance. It is further desirable that the lateral brace or alining bar shall have its lateral projection at a point below the flanges of the wheels resting upon the rail.

The preferred construction is shown in Fig. 2, where it will be seen that the reinforcement or alining bar 9 has the form of a T in cross-section, with the stem, web, or flange thereof extending laterally from the side of the rail, perpendicular thereto, and somewhat below half the height of the rail. The upper and lower edges of the T are preferably formed to fit the under part of the rail-head and the top of the rail-flange. The T is secured by rivets 10 passing through the upper and lower parts thereof above and below the lateral portion, and these rivets, preferably staggered, are arranged within a few inches of one another, and it is practically impossible that any part of the switch-point should become detached from the reinforcing or alining bar, even when the switch-point is broken in several places.

It is obvious that an angle-iron of suitable cross-section could be employed in place of

the T-iron; but there are objections thereto which make preferable the cross-sections that I have illustrated.

In place of the T illustrated in Fig. 2 I may employ a light deck-beam the cross-section of which is illustrated in Fig. 4, and I may further modify the section of the lateral reinforcement or alining bar 9, as shown in Fig. 5, the same being a channel or angle bar the edges of which are set against the head and flange of the rail, with rivets 10 passing through the rail-web.

The reinforcing-bar 9 adds strength to the switch-point, rendering the same less liable to breakage, also holding the broken pieces together when the switch-point is fractured, and, furthermore, holding the broken parts in line, so that the switch will serve for a short time until repairs are possible.

A particular advantage of this switch follows from the great rigidity that is afforded the switch-points, rendering it possible to dispense with the usual bridle-rods, and, further, making the operation therewith of an automatic switch-stand absolutely positive when the switch is thrown by a train running through the same when the switch was set against it.

It is obvious that my invention admits of various modifications, which will readily suggest themselves to one skilled in the art, and I therefore do not confine the same to the specific construction herein shown and described.

Having thus described my invention, I claim as new and desire to secure by Letters Patent—

1. The combination, with a movable switch-rail, of a laterally-extending inflexible reinforcement thereon, upon the gage side thereof.

2. The combination, with the movable switch-rail, of a laterally-extending inflexi-

ble reinforcement extending beyond the gage side of the rail-head.

3. The combination, with the movable switch-rail, of a bar secured to the gage side of the rail, and having a part extending laterally therefrom, for the purpose specified.

4. The combination, with the movable switch-rail, of the reinforcement or alining bar having a laterally-extending portion projecting beyond the gage side of the rail and below the path of a wheel-flange thereon, substantially as described.

5. The combination, with the movable switch-rail, of an alining-bar secured to the gage side thereof by rivets or equivalent devices passing through the rail-web, said bar having a horizontal portion of substantially the length thereof, substantially as described.

6. The combination, with the movable switch-rail, of the T-bar, the head-flanges of which are riveted to the gage side or inside of the rail-web.

7. A railroad-switch comprising the main and side track rails, and the swinging switch-points having their free ends only connected, and the laterally-extending alining-bars upon the gage sides of said switch-points.

8. A railroad-switch comprising the main and side track rails and the swinging switch-points, having their free ends connected, and the alining-bars secured to the gage sides of said switch-points and having horizontal webs or projections below the parts of the wheel-flange, substantially as described.

In testimony whereof I have hereunto set my hand, this 4th day of November, 1899, at Minneapolis, Minnesota.

HOWARD G. KELLEY.

In presence of—

C. G. HAWLEY,
M. E. GOOLEY.