



(51) International Patent Classification:

A61F 7/00 (2006.01) A61F 7/08 (2006.01)
A61F 7/02 (2006.01) A61F 7/10 (2006.01)
A61F 7/03 (2006.01)

(21) International Application Number:

PCT/US2019/039625

(22) International Filing Date:

27 June 2019 (27.06.2019)

(25) Filing Language:

English

(26) Publication Language:

English

(30) Priority Data:

62/690,875 27 June 2018 (27.06.2018) US

(71) Applicant: COOLSYSTEMS, INC. [US/US]; 1800 Sutter Street, Suite 500, Concord, California 94520 (US).

(72) Inventors: HUFF, Bryan D.; 355 Sussex Cir, Vacaville, California 95687 (US). LOWE, Mark H.; 353 Merrilee Place, Danville, California 94526 (US).

(74) Agent: KEESEE, Jessica A. et al.; Meunier Carlin and Curfman LLC, 999 Peachtree Street NE, Suite 1300, Atlanta, Georgia 30309 (US).

(81) Designated States (unless otherwise indicated, for every kind of national protection available): AE, AG, AL, AM, AO, AT, AU, AZ, BA, BB, BG, BH, BN, BR, BW, BY, BZ,

CA, CH, CL, CN, CO, CR, CU, CZ, DE, DJ, DK, DM, DO, DZ, EC, EE, EG, ES, FI, GB, GD, GE, GH, GM, GT, HN, HR, HU, ID, IL, IN, IR, IS, JO, JP, KE, KG, KH, KN, KP, KR, KW, KZ, LA, LC, LK, LR, LS, LU, LY, MA, MD, ME, MG, MK, MN, MW, MX, MY, MZ, NA, NG, NI, NO, NZ, OM, PA, PE, PG, PH, PL, PT, QA, RO, RS, RU, RW, SA, SC, SD, SE, SG, SK, SL, SM, ST, SV, SY, TH, TJ, TM, TN, TR, TT, TZ, UA, UG, US, UZ, VC, VN, ZA, ZM, ZW.

(84) Designated States (unless otherwise indicated, for every kind of regional protection available): ARIPO (BW, GH, GM, KE, LR, LS, MW, MZ, NA, RW, SD, SL, ST, SZ, TZ, UG, ZM, ZW), Eurasian (AM, AZ, BY, KG, KZ, RU, TJ, TM), European (AL, AT, BE, BG, CH, CY, CZ, DE, DK, EE, ES, FI, FR, GB, GR, HR, HU, IE, IS, IT, LT, LU, LV, MC, MK, MT, NL, NO, PL, PT, RO, RS, SE, SI, SK, SM, TR), OAPI (BF, BJ, CF, CG, CI, CM, GA, GN, GQ, GW, KM, ML, MR, NE, SN, TD, TG).

Declarations under Rule 4.17:

— of inventorship (Rule 4.17(iv))

Published:

— with international search report (Art. 21(3))

(54) Title: THERMAL PERFORMANCE OPTIMIZATION IN A THERMAL THERAPY DEVICE

(57) Abstract: A rapid contrast therapy system can provide cold, heat/hot/warm (hereafter referred to as "hot"), and/or rapid contrast therapy, which involves rapidly alternating between cold therapy and hot therapy. The system can circulate cold or hot fluid, such as water, through a hose, into a therapy wrap, and then back to the fluid reservoirs of the system. The system can utilize a vapor compression system or other chiller technology to cool the cold water reservoir, and immersion heaters can be used to heat the hot water reservoir.

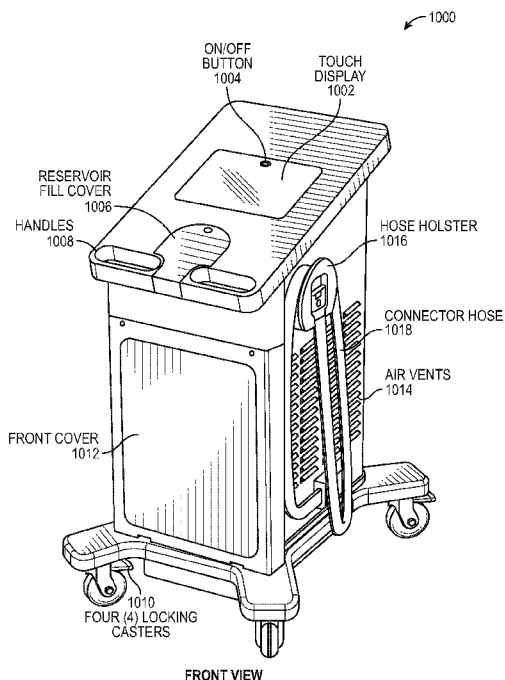

FIG. 1A



THERMAL PERFORMANCE OPTIMIZATION IN A THERMAL THERAPY DEVICE**CROSS REFERENCE TO RELATED APPLICATIONS**

[0001] This application claims priority to U.S. Provisional Application No. 62/690,875, filed June 27, 2018. This application may be related to International Application No. PCT/US2018/14556, filed January 19, 2018, which claims priority to U.S. Provisional Application No. 62/448,367, filed January 19, 2017, which is herein incorporated by reference in its entirety.

INCORPORATION BY REFERENCE

[0002] All publications and patent applications mentioned in this specification are herein incorporated by reference to the same extent as if each individual publication or patent application was specifically and individually indicated to be incorporated by reference.

FIELD

[0003] The present invention relates generally to thermal therapy of an animate body, and more particularly to rapid contrast therapy which alternates rapidly between cold therapy and hot therapy.

BACKGROUND

[0004] It is now common to apply cold and compression to a traumatized area of a human body to facilitate healing and prevent unwanted consequences of the trauma. In fact, the acronym RICE (Rest, Ice, Compression and Elevation) is now used by many.

[0005] Typically thermally-controlled therapy involves cold packing with ice bags or the like to provide deep core cooling of a body part. Therapy often involves conventional therapy wraps with a fluid bladder for circulating a cooled heat exchange medium. Elastic wraps are often applied over the therapy wrap to provide compression.

[0006] More recently therapy wraps including a pair of compliant bladders to contain fluids have been disclosed. The therapy wrap typically has a compliant bladder for containing a circulating heat exchange liquid alone or in combination with a compressive bladder which overlays the compliant bladder for pressing the bladder against the body part to be subjected to heat exchange. In general, the body heat exchanging component(s) of such an apparatus include a pair of layers defining a flexible fluid bladder through which a liquid is circulated. The structure embodying both the liquid bladder and compressive bladder component is often

referred to as a “wrap.” The liquid fed to the wrap is maintained at a desired temperature by passing the liquid through a heat exchanging medium such as an ice bath or a refrigeration unit. One such system is disclosed, for example, in U.S. Pat. No. 6,178,562 to Elkins, the disclosure of which is herein incorporated for all purposes by reference.

[0007] In some cases, heat treatment in conjunction with cryotherapy can provide benefits to the patient when provided in a rapidly alternating manner called rapid contrast therapy. Historically, this was done by alternating immersion in hot and cold water baths. However, use of hot and cold water baths is cumbersome and inconvenient to apply. Therefore, it would be desirable to provide a system and method for conveniently delivering rapid contrast therapy, cold therapy alone, heat therapy alone, and/or compression therapy.

SUMMARY OF THE DISCLOSURE

[0008] The present invention relates generally to thermal therapy of an animate body, and more particularly to rapid contrast therapy which alternates rapidly between cold therapy and hot therapy.

[0009] In some embodiments, a system for providing rapid contrast therapy is provided. The system includes a cold reservoir configured to hold a cold liquid; a hot reservoir configured to hold a hot liquid; a cold fill port in fluid communication with the cold reservoir; a hot fill port in fluid communication with the hot reservoir, wherein both the cold fill port and the hot fill port are housed in a receptacle that is configured to accommodate fluid overflow from the cold reservoir and the hot reservoir by allowing the cold liquid to overflow from the cold reservoir and into the hot reservoir or the hot liquid to overflow from the hot reservoir and into the cold reservoir; a chiller configured to cool the cold liquid; a first pump configured to pump the cold liquid from the cold reservoir to the chiller; a heater configured to heat the hot liquid; a second pump configured to pump the hot liquid from the hot reservoir to the heater; a user interface configured to allow a user to set one or more parameters of the rapid contrast therapy; and a controller configured to operate the chiller, the heater, the first pump, and the second pump based on the parameters selected by the user using the user interface.

[00010] In some embodiments, the system further includes a first pressure sensor located on the bottom of the cold reservoir and a second pressure sensor located on the bottom of the hot reservoir.

[00011] In some embodiments, the system further includes a first liquid level sensor in the cold reservoir and a second liquid level sensor in the hot reservoir.

[00012] In some embodiments, the system further includes an overflow conduit extending from an upper portion of the cold reservoir to an upper portion of the hot reservoir, wherein the overflow conduit provides fluid communication between the cold reservoir and the hot reservoir.

[00013] In some embodiments, the heater is disposed in the hot reservoir.

[00014] In some embodiments, the system further includes a heating element disposed in the cold reservoir.

[00015] In some embodiments, the system further includes a heater baffle disposed proximate the heater, wherein the heater baffle is configured to induce convection of the hot liquid around the heater.

[00016] In some embodiments, the system further includes temperature sensors configured to measure a temperature of the hot liquid and a temperature of the cold liquid.

[00017] In some embodiments, the system further includes a third pump configured to pump cold liquid from the cold reservoir to a therapy wrap, and a fourth pump configured to pump hot liquid from the hot reservoir to the therapy wrap.

[00018] In some embodiments, the system further includes a compressor configured to pressurize and depressurize a therapy wrap.

[00019] In some embodiments, the controller is configured to level the liquids in the hot reservoir and the cold reservoir when the system is not being used to actively treat a patient.

[00020] In some embodiments, the controller is configured to level the liquids in the hot reservoir and the cold reservoir when the first liquid level sensor or the second liquid level sensor detects a critical liquid level.

[00021] In some embodiments, the system further includes a plurality of valves configured to control the flow of liquids throughout the system.

[00022] In some embodiments, the valves are solenoid valves.

[00023] In some embodiments, a system for providing rapid contrast therapy is provided. The system includes a cold reservoir configured to hold a cold liquid; a cold therapy supply valve in fluid communication with the cold reservoir, the cold therapy supply valve directing the flow of the cold liquid to a therapy device; a hot reservoir configured to hold a hot liquid; a hot therapy supply valve in fluid communication with the hot reservoir, the hot therapy supply valve directing the flow of the hot liquid to the therapy; and a return valve directing return flow from the therapy device to at least one of the hot and cold reservoirs; and a controller directing operation of the cold and hot therapy supply valves to control the flow of the cold liquid and the hot liquid to the therapy device, the controller directing operation of the return valve to control the return liquid flowing from the therapy device to at least one of the cold and hot reservoirs.

[00024] In some embodiments, the system further includes a first liquid level sensor in the cold reservoir to measure a level of the cold liquid; a second liquid level sensor in the hot reservoir to measure a level of the hot liquid; a first temperature sensor to measure a temperature of the cold liquid; a second temperature sensor to measure a temperature of the hot liquid; and a return temperature sensor for measuring a temperature of the return flow from the therapy device.

[00025] In some embodiments, the first temperature sensor is provided in cold liquid recirculation manifold and the second temperature sensor is provided in the hot liquid recirculation manifold.

[00026] In some embodiments, the first temperature sensor is provided in the cold liquid reservoir and the second temperature sensor is provided in the hot liquid reservoir.

[00027] In some embodiments, the controller directs return flow from the therapy device to at least one of the cold and hot reservoirs after determining that the measured liquid level within each of the cold and hot reservoirs is within a target liquid level range, wherein the controller directs the return flow to either the cold reservoir or the hot reservoir depending on the temperature of the return flow such that the return flow is directed to the reservoir containing the liquid having a closest temperature with the temperature of the return flow. The target liquid level range in each of the cold and hot reservoirs is greater than a corresponding minimum liquid level and less than a corresponding maximum liquid level.

[00028] In some embodiments, the controller directs return flow from the therapy device to at least one of the cold and hot reservoirs after determining that the measured liquid level within each of the cold and hot reservoirs is within a target liquid level range, wherein the controller directs the return flow to the hot reservoir when the temperature of the return flow is greater than an average of the temperatures of cold and hot liquids.

[00029] In some embodiments, the controller directs return flow from the therapy device to at least one of the cold and hot reservoirs after determining that the measured liquid level within each of the cold and hot reservoirs is within a target liquid level range, wherein the controller directs the return flow to the hot reservoir when the temperature of the return flow is greater than an average of the temperatures of cold and hot liquids by more than a predetermined offset amount.

[00030] In some embodiments, the predetermined offset amount is 0.5°F.

[00031] In some embodiments, the controller directs return flow from the therapy device to at least one of the cold and hot reservoirs after determining that the measured liquid level within each of the cold and hot reservoirs is within a target liquid level range, wherein controller directs

return flow to the hot reservoir when the temperature of the return flow is equal to or greater than the temperature of the hot liquid in the hot reservoir.

[00032] In some embodiments, the controller directs return flow from the therapy device to at least one of the cold and hot reservoirs after determining that the measured liquid level within each of the cold and hot reservoirs is within a target liquid level range, wherein controller directs the return flow to the hot reservoir when the temperature of the return flow is greater than the temperature of the cold liquid in the cold reservoir.

[00033] In some embodiments, the controller directs return flow from the therapy device to at least one of the cold and hot reservoirs after determining that the measured liquid level within each of the cold and hot reservoirs is within a target liquid level range, wherein the controller directs the return flow to the hot reservoir when the temperature of the return flow is greater than a maximum cold reservoir return temperature.

[00034] In some embodiments, the maximum cold reservoir return temperature corresponds to the temperature of the cold liquid in the cold reservoir (measured in °F) plus an offset amount,

[00035] In some embodiments, the wherein the offset amount is 0.5 °F.

[00036] In some embodiments, the system further includes one or more conduits extending between the cold reservoir and the hot reservoir, the conduit providing fluid communication therebetween; and one or more cross-tank valves for controlling flow through the conduit; wherein the controller directs operation of the one or more cross-tank valves to control flow between the cold and hot reservoirs, wherein the controller directs operation of the one or more cross-tank valves in response to the measured liquid level in each of the cold and hot reservoirs such that the liquid level in either the cold and hot reservoirs does not exceed a maximum liquid level or fall below a minimum liquid level.

[00037] In some embodiments, the one or more cross-tank valves of the conduit is biased in a closed position.

[00038] In some embodiments, the system further includes a pump for moving liquid through the conduit.

[00039] In some embodiments, the conduit is connected to a recirculation pump for moving fluid through the conduit between the cold and hot reservoirs.

[00040] In some embodiments, the minimum liquid level of the cold and hot reservoirs is 60% of a full operating liquid level of the corresponding cold and hot reservoir.

[00041] In some embodiments, the minimum liquid level of the cold and hot reservoirs is 72% of a full operating liquid level of the corresponding cold and hot reservoirs.

[00042] In some embodiments, the minimum liquid level of the cold and hot reservoirs is 3.75". In some embodiments, the full operating liquid level of the cold and hot reservoir ranges between 5–6".

[00043] In some embodiments, the minimum liquid level is 3.6". In some embodiments, the full operating liquid level of the cold and hot reservoir ranges between 5–6".

[00044] In some embodiments, the controller directs flow through the conduit from the hot reservoir to the cold reservoir when the first liquid level sensor measures a liquid level below the minimum liquid level for the cold reservoir, wherein the controller directs flow through the conduit from the cold reservoir to the hot reservoir when the second liquid level sensor measures a liquid level below the minimum liquid level for the hot reservoir.

[00045] In some embodiments, the controller directs flow through the conduit from the cold reservoir to the hot reservoir when the first liquid level sensor measures a liquid level above the maximum liquid level for the cold reservoir, wherein controller directs flow through the conduit from the hot reservoir to the cold reservoir when the second liquid level sensor measures a liquid level above the maximum liquid level for the hot reservoir.

[00046] In some embodiments, during operation at least one of the cold and hot liquids is provided to a therapy device and the return flow is received from the therapy device and directed to the cold or hot reservoirs, wherein, during operation the controller directs operation of the cross-tank valve to open fluid communication between the reservoirs for a first time period.

[00047] In some embodiments, the controller directs cycled operation of the cross-tank valve to open and close fluid communication between the reservoirs, such that during each open-close cycle the cross-tank valve is open for the first time period and closed for a second time period until the difference between the measured liquid levels in the cold and hot reservoirs is within a predetermined deviation amount.

[00048] In some embodiments, the first time period is 5 seconds and the second time period is 5 seconds.

[00049] In some embodiments, the minimum liquid level of the cold and hot reservoirs corresponds to a liquid level where the cold and hot reservoirs indicate a critically low operating condition.

[00050] In some embodiments, the predetermined deviation amount is $1/4" \pm 1/8"$.

[00051] In some embodiments, the system is not operating when at least one of the cold and hot liquids have not been provided to the therapy device for a predetermined off period, wherein, when the system is not operating, the controller directs operation of the cross-tank valve to open fluid communication between the reservoirs for a first time period.

[00052] In some embodiments, the predetermined off period that the therapy system is not operating is less than or equal to 20 seconds.

[00053] In some embodiments, the predetermined off period that the therapy system is not operating is at least 5 second.

[00054] In some embodiments, the predetermined off period that the therapy system is not operating is at least 10 seconds.

[00055] In some embodiments, the controller directs operation of the cross-tank valve to open fluid communication between the reservoirs until the difference between the measured liquid levels in the cold and hot reservoirs is within a predetermined deviation amount.

[00056] In some embodiments, the predetermined deviation amount is $1/4'' \pm 1/8''$.

[00057] In some embodiments, the controller directs cycled operation of the cross-tank valve to open and close fluid communication between the reservoirs, such that during each open-close cycle the cross-tank valve is open for the first time period and closed for a second time period until the difference between the measured liquid levels in the cold and hot reservoirs is within a predetermined deviation amount.

[00058] In some embodiments, the first time period is 5 seconds and the second time period is 5 seconds.

[00059] In some embodiments, the predetermined deviation amount is $1/4'' \pm 1/8''$.

[00060] In some embodiments, the return valve comprises a cold reservoir return valve and a hot reservoir return valve, wherein the cold reservoir return valve directs return flow from the therapy device to the cold reservoir, wherein the hot reservoir return valve directs return flow from the therapy device to the hot reservoir.

[00061] In some embodiments, the system further includes at least one of the cold therapy supply valve, the hot therapy supply valve, the return valve and the cross-tank valve can be adjusted by the controller to vary at least one of a flow rate, volume, flow pressure, and temperature of the flow of liquid therethrough.

[00062] In some embodiments, the return temperature sensor is provided upstream of the return valve such that the return temperature sensor is between an output of the therapy device and the return valve.

[00063] In some embodiments, the therapy device comprises a therapy wrap configured for wrapping to a portion of an animate body for delivering treatment.

[00064] In some embodiments, the cold reservoir includes a cold reservoir fill port and the hot reservoir includes a hot reservoir fill port, wherein the cold and hot reservoir fill ports are housed in a receptacle that is configured to accommodate fluid overflow from the cold reservoir and the hot reservoir by allowing the cold liquid to overflow from the cold reservoir and into the hot reservoir or the hot liquid to overflow from the hot reservoir and into the cold reservoir.

[00065] In some embodiments, the system further includes a first pump configured to pump cold liquid from the cold reservoir to the therapy device; and a second pump configured to pump hot liquid from the hot reservoir to the therapy device.

[00066] In some embodiments, the system further includes a chiller configured to cool the cold liquid, and a third pump (recirculating pump) configured to pump the cold liquid from the cold reservoir to the chiller.

[00067] In some embodiments, the third pump (recirculating pump) is configured to pump cold liquid to the hot reservoir.

[00068] In some embodiments, the third pump is located upstream of the first pump.

[00069] In some embodiments, the cold therapy supply valve is located downstream from the first pump

[00070] In some embodiments, the system further includes a heater configured to heat the hot liquid; and a fourth pump (recirculating pump) configured to pump the hot liquid from the hot reservoir to the heater.

[00071] In some embodiments, the heater is disposed in the hot reservoir.

[00072] In some embodiments, the system further includes a heater baffle disposed proximate the heater, wherein the heater baffle is configured to induce convection of the hot liquid around the heater.

[00073] In some embodiments, the fourth pump (recirculating pump) is configured to pump hot liquid to the cold reservoir.

[00074] In some embodiments, the fourth pump is located upstream of the second pump.

[00075] In some embodiments, the hot therapy supply valve is located downstream from the second pump.

[00076] In some embodiments, the system further includes a first pressure sensor located on the bottom of the cold reservoir, and a second pressure sensor located on the bottom of the hot reservoir.

[00077] In some embodiments, the system further includes a heating element disposed in the cold reservoir.

[00078] In some embodiments, the system further includes an overflow conduit extending from an upper portion of the cold reservoir to an upper portion of the hot reservoir, wherein the overflow conduit provides fluid communication between the cold reservoir and the hot reservoir.

[00079] In some embodiments, the system further includes a compressor configured to pressurize the therapy device.

[00080] In some embodiments, the system further includes a user interface configured to allow a user to set one or more parameters of the rapid contrast therapy; and wherein the controller operates at least one of a chiller, a heater, the first pump, and the second pump based on the parameters selected by the user using the user interface.

[00081] In some embodiments, a method for providing rapid contrast therapy using a rapid contrast therapy device is provided. The method includes applying a therapy wrap to a patient; connecting a therapy wrap connector to a treatment device connector, the therapy device connector providing fluid communication between the therapy wrap and a cold therapy supply line, a hot therapy supply line and a pressurized gas supply line; measuring a liquid level of a cold and hot liquid within a cold and hot liquid reservoir provided in the therapy device; confirming a measured liquid level within each of the cold and hot reservoirs is within a target liquid level range; providing at least one of a temperature therapy and a pressure therapy to the patient via the therapy wrap by directing at least one of a cold liquid, a hot liquid and a pressurized gas through therapy wrap via a corresponding cold therapy supply valve, hot therapy supply valve and gas therapy supply valve; controlling via a return valve a return flow of the liquid from the therapy wrap to at least one of the cold and hot reservoirs to minimize the unnecessary thermal pollution of hot water from entering the cold tank or cold water from entering the hot tank upon return from the therapy wrap.

[00082] In some embodiments, the method the return flow is directed to either the cold reservoir or the hot reservoir depending on the temperature of the return flow such that the return flow is directed to the reservoir containing the liquid having a closest temperature with the temperature of the return flow.

[00083] In some embodiments, the return flow is directed to the hot reservoir when the temperature of the return flow is greater than an average of the temperatures of cold and hot liquids.

[00084] In some embodiments, the return flow is directed to the hot reservoir when the temperature of the return flow is greater than an average of the temperatures of cold and hot liquids by more than a predetermined offset amount.

[00085] In some embodiments, the predetermined offset amount is 0.5°F.

[00086] In some embodiments, the return flow is directed to the hot reservoir when the temperature of the return flow is equal to or greater than the temperature of the hot liquid in the hot reservoir.

[00087] In some embodiments, the return flow is directed to the hot reservoir when the temperature of the return flow is greater than the temperature of the cold liquid in the cold reservoir.

[00088] In some embodiments, the return flow is directed to the hot reservoir when the temperature of the return flow is greater than a maximum cold reservoir return temperature.

[00089] In some embodiments, the maximum cold reservoir return temperature corresponds to the temperature of the cold liquid in the cold reservoir (measured in °F) plus an offset amount,

[00090] In some embodiments, the offset amount is 0.5 °F.

[00091] In some embodiments, the measured liquid level within either of the cold and hot reservoirs is not within a target liquid level range the return flow is directed to either the cold reservoir or the hot reservoir depending on the measured liquid level in each of the cold and hot reservoirs such that the measured liquid level in the cold and hot reservoirs does not exceed the corresponding maximum liquid level or fall below the corresponding minimum liquid level.

[00092] In some embodiments, the return flow is directed to the cold reservoir when the first liquid level sensor measures a liquid level below the minimum liquid level for the cold reservoir, and wherein the return flow is directed to the hot reservoir when the second liquid level sensor measures a liquid level below the minimum liquid level for the hot reservoir.

[00093] In some embodiments, the return flow is directed to the hot reservoir when the first liquid level sensor measures a liquid level above a maximum liquid level for the cold reservoir, and wherein return flow is directed to the cold reservoir when the second liquid level sensor measures a liquid level above the maximum liquid level for the hot reservoir.

[00094] In some embodiments, the method further includes directing a cross-tank flow of the cold and hot liquids between the cold and hot reservoirs via a conduit operated by a cross-tank valve, where the cross-tank flow is directed in response to the measured liquid levels in each of the cold and hot reservoirs such that the liquid level in either the cold and hot reservoirs does not exceed a maximum liquid level or fall below a minimum liquid level.

[00095] In some embodiments, the method further includes directing flow through the conduit from the hot reservoir to the cold reservoir when the first liquid level sensor measures a liquid level below the minimum liquid level for the cold reservoir.

[00096] In some embodiments, the method further includes directing flow through the conduit from the cold reservoir to the hot reservoir when the second liquid level sensor measures a liquid level below the minimum liquid level for the hot reservoir.

[00097] In some embodiments, the method further includes directing flow through the conduit from the cold reservoir to the hot reservoir when the first liquid level sensor measures a liquid level above the maximum liquid level for the cold reservoir.

[00098] In some embodiments, the method further includes directing flow through the conduit from the hot reservoir to the cold reservoir when the second liquid level sensor measures a liquid level above the maximum liquid level for the hot reservoir.

[00099] In some embodiments, the during operation of the therapy device at least one of the cold and hot liquids is provided to the therapy wrap and the return flow is received from the therapy wrap and directed to the cold or hot reservoirs, wherein during operation of the therapy device, directing operation of the cross-tank valve to open fluid communication between the reservoirs for a first time period.

[000100] In some embodiments, the method further includes directing cycled operation of the cross-tank valve to open and close fluid communication between the reservoirs, such that during each open-close cycle the cross-tank valve is open for the first time period and closed for a second time period until the difference between the measured liquid levels in the cold and hot reservoirs is within a predetermined deviation amount.

[000101] In some embodiments, the minimum liquid level of the of the cold and hot reservoirs corresponds to a liquid level where the cold and hot reservoirs indicate a critically low operating condition.

[000102] In some embodiments, the therapy device is not operating when at least one of the cold and hot liquids have not been provided to the therapy wrap for a predetermined off period, when the therapy device is not operating, directing operation of the cross-tank valve to open fluid communication between the reservoirs for a first time period.

[000103] In some embodiments, the method further includes directing cycled operation of the cross-tank valve to open and close fluid communication between the reservoirs, such that during each open-close cycle the cross-tank valve is open for the first time period and closed for a second time period until the difference between the measured liquid levels in the cold and hot reservoirs is within a predetermined deviation amount.

BRIEF DESCRIPTION OF THE DRAWINGS

[000104] The novel features of the invention are set forth with particularity in the claims that follow. A better understanding of the features and advantages of the present invention will be obtained by reference to the following detailed description that sets forth illustrative embodiments, in which the principles of the invention are utilized, and the accompanying drawings of which:

[000105] FIGS. 1A–1B illustrate a system for providing cold, heat/hot/warm (hereafter referred to as “hot”), and/or rapid contrast therapy.

[000106] FIG. 2 illustrates an embodiment of a user interface that can serve as a control panel.

[000107] FIG. 3 illustrates various pressure curve profiles.

[000108] FIGS. 4A and 4B illustrate an embodiment of a therapy wrap.

[000109] FIGS. 5A–5C illustrate an embodiment of the system being refilled using the refill port and drained using the drain ports.

[000110] FIGS. 6, 7, 8A and 8B are schematic diagrams that illustrate various embodiments of the system.

[000111] FIGS. 9A and 9B illustrate an embodiment of a cold reservoir and a hot reservoir.

[000112] FIG. 10A–10B present various parameters that are used by the system.

[000113] FIGS. 11A–11O illustrate various screens displayed by the touch screen interface.

[000114] FIG. 12 is graph of tank temperatures using various temperature control algorithms.

DETAILED DESCRIPTION

[000115] FIGS. 1A–1B and illustrate a system 1000 for providing cold, heat/hot/warm (hereafter referred to as “hot”), and/or rapid contrast therapy, which involves rapidly alternating between cold therapy and hot therapy. The system can circulate cold or warm fluid, such as water, through a hose, into a therapy wrap, and then back to the fluid reservoirs of the system. The system can utilize a vapor compression system or other chiller technology to cool the cold water reservoir, and immersion heaters can be used to heat the hot water reservoir. The system can have two or more ports, in order to serve two or more patients simultaneously. Two or more air pumps can be utilized (one for each port) in order to provide pneumatic compression along with the thermal therapy. In other embodiments, the system may have a single port and single air pump to treat just a single patient.

[000116] In some embodiments, the system 1000 can have a user interface 1002 on an upper front facing panel. The user interface 1002 can be a touch display. An on/off power button 1004

can be provided. The on/off power button can be located on, in or near the user interface 1002. The upper front facing panel can also have a reservoir fill cover 1006 that can be opened to provide access to fill ports. Handles 1008 can also be provided to allow the user to move the system, which can have a base with 4 locking casters 1010. A removable or openable front cover 1012 can provide access to the internal components of the system. Air vents 1014, a hose holster 1016, and a connector hose 1018 can be located on one or both the sides of the system. [000117] The rear of the system can have a fan 1020, additional air vents 1022, drain ports 1024, a USB port 1026 and/or network port, an additional on/off power switch 1028, a power cord inlet 1030, and equipotential ground pins 1032.

Therapy Modalities:

[000118] **COOLING:** water can be supplied and returned to the cold reservoir as controlled by the flow control valves associated with the port. Since there is only one cold reservoir in some embodiments, the cold reservoir temperature control may be common to both ports, or all ports for embodiments with more than 2 ports, and the temperature may be adjustable from the user interface, such as the home screen which can be the default display screen. Each port can have individual settings for treatment parameters, including treatment temperatures and duration and air pressure, which allow the system to deliver customized treatment to each wrap connected to the system.

[000119] **HEATING:** water can be supplied and returned to the hot reservoir as controlled by the flow control valves associated with the port. Since there may be only one hot reservoir in some embodiments, the hot reservoir temperature control may be common to both ports, or all ports for embodiments with more than 2 ports, and its temperature may be adjustable from the user interface, such as the home screen which can be the default display screen. Each port can have individual settings for treatment parameters, including treatment temperatures and duration and air pressure, which allow the system to deliver customized treatment to each wrap connected to the system.

[000120] **CONTRAST:** water supplied to the wraps can alternate between the hot and cold reservoirs based on the separate and customizable hot duration and temperature and cold duration and temperature settings. A typical treatment is alternating 3 min hot and 1 min cold. In some embodiments, durations of less than one min on either hot or cold therapy to prevent the wraps from being half filled with warm/hot water and half filled with cold water. Air pressure can also be adjustable separately for the hot and cold treatments. For example the pressure could be set to high (i.e., 75mmHg) during cold and med low (i.e., 25 mmHg) during hot. In some

embodiments, the pressure applied during cold treatment can be higher during cold treatment than hot treatment to work alongside with vasoconstriction during cold treatment. Heat causes vasodilation, and blood rushes in – so air pressure may be counterproductive with heat therapy, which means using a lower pressure during heat treatment may be beneficial. In some embodiments, treatment duration selections may be limited to whole cycle values to end in a certain mode. For example, a hot and cold cycle may be limited to minute increments, and a combined hot and cold cycle duration may be limited to a set value or upper limit. For example, the single combined hot cold cycle may not exceed 4 minutes in some embodiments, meaning if the hot treatment is 3 minutes, then the cold treatment is 1 minute. In some embodiments, a hot cold cycle may be limited to 2 to 10 minutes, or 4 to 20 minutes, or 2 to 30 minutes. In some embodiments, the total treatment is configured to end with cold treatment or hot treatment by configuring the treatment times and number of cycles.

[000121] COMPRESSION ONLY: water is not pumped through the wraps but air or another gas can be pumped into the wrap. Treatment duration, air pressure, and optionally the pressure curve profile (the ramping up, maintenance, and release of pressure over time) will be adjustable.

[000122] COMPRESSION WITH THERMAL THERAPY: The thermal therapies described herein can be combined with the compression therapy.

CONTROL PANEL(S):

[000123] FIG. 2 illustrates an embodiment of a user interface 2000 that can serve as a control panel. The user interface 2000 can be a touch screen with graphical icons that represent the different treatment modalities and can include adjustable parameter settings, such as hot and cold temperature settings for example. For example, the control panel can use a 7" touchscreen TFT set in a traditional domed membrane switch. Most of the controls can be on the TFT display. A few buttons like power, STOP, home, etc. can be on the membrane switch. In some embodiments, a capacitive touch screen can be used.

AIR PRESSURE PROFILES:

[000124] In various embodiments, in the cooling mode the pressure of gas furnished by the control unit is between about 0.25 psig and about 20 psig, preferably between about 0.25 psig and about 5 psig, and more preferably about 0.25 to about 1.5 psig. In various embodiments, the control unit maintains a compressive force of between about 0.25 psig and about 5 psig. In various embodiments, the control unit maintains a compressive force of between about 0.25 psig

and about 0.5 psig. In various embodiments, the pressure of gas furnished by the control unit is user selectable in increments of 5 mm Hg from 0 mm to about 75 mm.

[000125] In various embodiments, the pressure of gas furnished by the control unit is based on the patient's response. For example, if the patient is wearing the wrap during exercise, the pressure may vary based on how strenuous the exercise is. If the patient is having trouble breathing, the control unit may decrease the compressive force around the lungs. The pressure profile map may be set to adjust based on a predetermined routine. In various embodiments, the pressure profile map includes 3 minutes of slowly increasing pressure followed by 2 minutes of decreasing pressure. In various embodiments, the pressure profile map includes 30 seconds of increasing pressure followed by 15 seconds of decreasing pressure. In various embodiments, the pressure fluctuates at random. In various embodiments, the pressure profile map includes 2 minutes of compression followed by 1 minute with no compression.

[000126] The strength and frequency of the pulses may be modified depending on the application. In various embodiments, the control unit delivers pulses of compression for massaging therapy.

[000127] In various embodiments the wrap can be used with a rigid or semi-rigid support such as a brace. In various embodiments, the control unit can apply and maintain a low pressure or no pressure when the control unit detects a brace in use with the wrap. In various embodiments, the control unit can apply and maintain higher pressures when the control unit detects a brace not in use with the wrap. In some embodiments, a low pressure is less than 10 psig, 5 psig, 4 psig, 3 psig, 2 psig, 1 psig, or 0.5 psig. In some embodiments, a high pressure is greater than 0.5 psig, 1 psig, 2 psig, 3 psig, 4 psig, 5 psig, or 10 psig.

[000128] In heating mode, the same pressures will be available as for the cold settings.

[000129] FIG. 3 illustrates various pressure curve profiles: high (about 75 mmHg), medium high (about 50 mmHg), medium low (about 25 mmHg), and low (about 15 mmHg). The ramp time can be about 2 minutes to achieve the target pressure for high, medium high, and medium low, while the ramp time for low can be about 1 minute. The ramp times and target temperatures for the different settings can be adjustable, or can be predetermined and fixed.

[000130] In some embodiments, the default pressures for the cooling and heating modes is different. In other embodiments, the default pressures for the cooling and heating modes is the same.

[000131] In contrast therapy mode, the therapy profile can specify the cold duration and temperature and compression, the hot duration and temperature and compression, and the duration of treatment or number of cycles to be run.

[000132] In some embodiments, the system allows named preset therapy sessions to be configured and saved by the user that can be later selected directly by name and/or a unique icon.

WRAPS:

[000133] Further details regarding wraps, fluid bladders, air bladders, and their operation and manufacture are described in U.S. Patent Nos. 7,837,638; 7,198,093 and 6,695,872, both to Elkins, U.S. Patent Publication Nos. 2014/0142473, the entire contents of which are incorporated herein for all purposes by reference.

[000134] FIGS. 4A and 4B illustrate an embodiment of a therapy wrap. The therapy wrap 20 is configured for wrapping to a portion of an animate body for delivering treatment. The body may include, but is not limited to, a mammalian body such as a human or an equine animal. The exemplary therapy wrap is in the form of a sleeve for connecting various components of heat transfer device 22 to the patient's body. The sleeve is similar in many respects to the sleeve disclosed by U.S. Patent No. 7,896,910 to Schirmacher et al. and cover disclosed by U.S. Patent No. 6,695,872 to Elkins, the entire contents of which patents are incorporated herein for all purposes by reference.

[000135] Exemplary therapy wrap 20 includes an opening 19 for directing heat transfer device 22 into a pouch or cavity in the sleeve interior. A portion of sleeve may be pulled back to reveal the pouch and facilitate positioning of the heat transfer device in the pouch as shown in FIG. 4A. Any suitable fastening means can be used to close the opening such as, but not limited to, a zipper.

[000136] The pouches may be selectively positioned in predetermined locations on therapy wrap 20. In other words, the pouches may be fixed into a position on the wrap based on parameters defined before use of the wrap. Such parameters may include user preferences or application demands. In various embodiments, the sleeve is configured to position a bladder in one of a plurality of predefined locations. The predefined locations may be determined by user preferences. In various embodiments, the predefined locations correspond to key areas for core cooling of the body.

[000137] Therapy wrap 20 may have a variety of shapes and sizes for applying to different portions of the body or different body anatomies. The sleeve may be shaped and configured for application to a mammal, and in various embodiments, a human. In various embodiments, the sleeve is shaped for applying to and covering all or part of a torso, a thoracic region, a cranial region, a throat region, a limb, and a combination of the same. Various aspects of the therapy wrap, in particular the sleeve, shape and design may be similar to the devices disclosed by U.S.

Patent Nos. 7,107,629 to Miros et al. and U.S. Patent Pub. No. 2005/0256556 A1 to Schirmacher et al., the entire contents of which are incorporated herein for all purposes by reference.

[000138] In general, “heat transfer device” refers to the body heat exchanging component(s). In various embodiments, the heat transfer device includes layers of material defining a flexible fluid bladder through which a liquid is circulated and a gas bladder in which a pressurized gas is injected. Exemplary heat transfer device 22 is in the form of a conventional multi-bladder assembly for positioning adjacent a treatment site of a body. In various aspects, the multi-bladder assembly is manufactured and configured using known techniques. A commonly used thermal bladder assembly uses both a compliant fluid bladder 25 for circulating heat transfer fluid and a gas pressure bladder 28 which overlays the fluid bladder (best seen in FIG. 4B). The gas pressure bladder is adapted to inhibit edema and/or for pressing the fluid bladder against the body part to be subjected to heat exchange.

[000139] More specifically, outer gas pressure bladder 28 is adapted to receive a first fluid such as a gas (e.g., air) that can be regulated to provide the desired amount of inflation of the bladder or pressure therein. This inflation or pressure affects the compressive force applied to the animate body during use. Inner fluid bladder 25 is adapted to receive a fluid, such as a coolant which can be in the form of a cold liquid, to transfer heat away from the animate body part. Alternatively, the fluid supplied to the inner bladder can have a temperature higher than the animate body part to heat the body part.

[000140] The hose and connector to attach the therapy wrap to the system can use a 3-port connector with a fluid inlet, a fluid outlet, and a gas port.

APPROXIMATE DIMENSIONS FOR ONE EMBODIMENT OF THE SYSTEM

Height	40 inches	1016 mm
Length	20 inches	500 mm
Width	17 inches	430 mm
Water Volume	3 gallon (1-5 gallons)	11 liter
Weight	150 pounds	45 Kg

WATER TEMPERATURES:

[000141] In some embodiments, the temperature of the hot reservoir can be adjustable from about 100 to 120 degF, and the temperature of the cold reservoir can be adjustable from about 38 to 60 degF. The temperature ranges can be determined by safety considerations (i.e., avoiding tissue damage) and freeze prevention of fluid in cold reservoir. In some embodiments, the range limits can be adjusted by the user. For example the upper range for the hot reservoir can be lowered by the user to, for example, 110 or 115F, and/or the lower range for the cold reservoir can be increased to 40 or 45 or 50F. In some embodiments, the user adjustable range is limited to adjustments made within a predetermined range so that the user cannot exceed a predetermined hot temperature limit or fall below a predetermined cold temperature limit.

WATER:

[000142] In some embodiments, distilled water is provided and/or recommended for use to reduce scaling. In the event distilled water is not used, descaling agents such as phosphoric acid, acetic acid, or citric acid can be flushed through the system. Instructions for descaling the system can be provided.

[000143] In some embodiments, addition of an antimicrobial and or scale inhibitor may also be recommended.

[000144] In some embodiments, the system is drained when not in use and drained/refilled periodically. As shown in FIGS. 5A–5C, to facilitate draining and refilling, the system 5000 can have easily accessible drain ports 5002 and fill ports 5004. The fill ports 5004 can be located on the front facing portion of system near the user interface for increased access, which allows the user to easily add more fluid to the system if needed, even during treatment. A removable or openable cover 5006 can cover the fill ports 5004.

TEMPERATURE CONTROL:

[000145] To make a reasonably sized system, the ratio of thermal mass to heat transfer suggests deviating from the traditional refrigeration temperature control methods.

[000146] FIGS. 6–8B are schematic diagrams that illustrate various embodiments of the system. As shown in FIG. 6, in some embodiments with an AC system, a hot gas bypass 6000 can be used and temperature can be controlled with an isolation valve 6002 upstream of the thermal expansion valve 6004. As shown in FIG. 7, if a variable speed DC compressor 7000 is used the power may be lowered to allow use of a heater 7002 in the cold tank 7004. FIG. 8A illustrates a schematic of the cold tank portion, and FIG. 8B illustrates a schematic of the hot

tank portion. FIGS. 8A and 8B illustrate pumps 8001, 8002, 8003, 8004 that can be used to pump fluid too the chiller 8005, the heater 8006, and between the cold tank 7004 and the hot tank 8007. For example, recirculation pump 8001 can be used to direct flow from the cold tank 7004 to the hot tank 8007, and recirculation pump 8003 can be used to direct flow from the hot tank 8007 to the cold tank 7004. The pumps in combination with a system of valves can be used to control the fluid flow in the system.

[000147] Return water strategy (i.e. when in Rapid Contrast mode).

[000148] In order to make the cooling and heating systems more efficient, it will be advantageous to delay switching of return water for a period of time after switching from hot to cold or from cold to hot, i.e., when switching from hot to cold, there will be about 300-750ml or some other volume of hot water still in the hoses and wraps. If return water switched at the same time as the supply water, a large volume of hot water would be pumped into the cold water tank. The inverse would be true when switching from cold back to hot. Return water switching could be delayed until the return water reached a predetermined temperature or time, which can be measured using a temperature sensor, such as a thermistor. Switching between reservoirs can be achieved using solenoid valves that can be opened and closed based on measurements from the temperature sensor. For example:

- $T = (T_h - T_c) / 2$
- $T = T_h - 10F$ (when switching from cold to hot)
- $T = T_c + 10F$ (when switching from hot to cold)
- Time = 60 seconds

[000149] Tank system

[000150] When water supply is switched during contrast therapy, the tanks will often be at different levels. There should be a method of protecting the system from overflow of one tank or another, and also a system to prevent one tank from running low on fluid.

[000151] A small equalization tube 6500 may be a solution as shown in FIGS. 6 and 7. This equalization tube 6500 would allow the tanks to equalize. The length and diameter of the tube could be sized to prevent fast equalization (which would dump hot water into the cold tank or vice versa). For example, the length and diameter of the tube can be sized to allow up to about 1%, 5%, or 10% of the tank volume in fluid to pass through per minute. The equalization tube 6500 can be located on the upper portion of each tank, such as the upper 1/20, 1/10, 1/5, 1/4, or 1/3.

[000152] A reversible pump between the reservoirs is another possible solution. This would have the advantage of being able to stop or start equalization at any time, and in any direction. Further advantage would be that hot water could be added to the cold tank, or vice versa, in order

to more rapidly reach a desired tank temperature (i.e., when changing tank temperatures) or to prevent overshoot, etc.

[000153] Another solution can be for overflow to be passed back and forth between the tanks at the filling ports shown in FIG. 5C. The filling ports can be housed in a receptacle that can accommodate fluid overflow from the reservoirs. As one reservoir overflows through its filling port, the receptacle is filled and the overflow fluid flows into the filling port of the other reservoir.

[000154] If the liquid levels in the tanks are equilibrated or balanced during therapy, either hot water is added to the cold tank or cold water is added to the hot tank, which reduces the temperature gradient between the hot and cold tanks. This change in tank temperatures during therapy may not be desirable. Therefore, in some embodiments, tank fluid level management, particularly the liquid leveling steps as described herein, can be generally performed outside of therapy, such as after therapy is completed. However, when the liquid level in a tank is critically low, a liquid leveling procedure can be used even during therapy to return the tank levels to non-critical levels. This liquid leveling procedure can be implemented, for example, through control of the pumps described herein in connection with FIGS. 8A and 8B, for example.

[000155] It would be advantageous to make filling the system easy and intuitive. Since there will be two tanks, it may be advantageous to only have one fill port, and not have to fill each reservoir individually. In other embodiments, each reservoir can have its own fill port, as shown in FIG. 5B. Directing the water into both the hot tank and cold tank equally may be a challenge. If the fill line is above the level of each reservoir, then both reservoirs would equalize at that point. However, that does not leave room for additional head height in either tank during use, and the two tanks would mix freely, thus making temperature control of each tank more difficult and inefficient. In some embodiments, an indicator on the user interface can indicate the fill level of the reservoirs and/or can indicate when a reservoir is fully filled. The tanks can have a fluid level sensor to determine the amount of fluid in the tank.

[000156] Therefore, an embodiment of a reservoir that addresses these concerns is shown in FIGS. 9A and 9B. The system comprises a Cold Reservoir 9001, a Hot Reservoir 9002 and a Fill Port 9006. Water may be poured into the Fill Port 9007 using a pitcher, hose, gallon jug, etc. Ease of filling may be aided by use of a wide, funnel or tapered shape to the fill port 9007. The fill port 9007 may be sealed by a Fill Cap assembly 9004. The fill cap assembly 9004 may include a Knob 9004A a strainer 9004B and a Tank Seal 9004C. The Tank Seal 9004C may be configured to provide an opening between the reservoirs and the ambient environment in one position (open position), and to seal the opening between the reservoirs and the ambient

environment in another position (closed position). In the open position, there may be a conduit that connects the Hot and Cold Reservoirs. This allows for water to equalize between the hot and cold reservoirs once an adequate fill level is attained (between the Upper Fill Level 9020 and Lower Fill Level 9021. When the Tank Seal 9004C is in the Closed Position, the conduit between the Hot and Cold reservoirs may be closed off, in order to prevent exchange of fluid as fluid levels 9008A-B and 9009A-B change independently within the system. Vents 9005, 9006 in the Reservoirs 9002, 9001 allow for the air pressure within the tanks to be nearly atmospheric.

[000157] Cold Water Outlet 9010 and Hot Water Outlet 9011 may be located at the bottom surface of the reservoir, or may be at a level just above the reservoir bottom to prevent sediment from entering the fluidics lines. Cold Water Inlet 9012 and Hot Water Inlet 9013 would desirably be configured such to encourage mixing within the reservoir. Proper mixing, or forced convection around the Heater 9015, is particularly important to efficiently heat the water tank, and reduce surface temperature on the heater, which in turn reduces the likelihood of scaling developing on the Heater 9015. For this reason, it may be desirable to include a Heater Baffle 9014 near the heater increase water velocity around the heater surface. The Heater Baffle 9014 may be designed such to provide a torturous water path to further reduce the boundary layer at the surface of the heater. A similar approach may be used if a Heater is used in the Cold Reservoir as well.

[000158] A sensor (preferably a Pressure Sensor) may be used in order to sense the water level in the tank. The Pressure Sensor 9016, 9018 would be best placed near the bottom of the tank to most accurately measure Head Pressure within the tank. Reservoir Vents 9005, 9006 would allow for accurate pressure measurement.

[000159] Water level may be equalized or adjusted via a Tank Level Facilitator 9003 located adjacent to the reservoirs. The Tank Level Facilitator 9003 may be passive, and could comprise of a simple orifice, or long length of tubing sized to provide a desired flowrate between the two reservoirs base simply on water level difference. The Tank Level Facilitator 9003 may also be an active device that pumps fluid from the Hot Reservoir 9002 to the Cold Reservoir 9001 or vice versa. This may be desirable if a significant water level imbalance is sensed, or to adjust the temperature in one of the tanks rapidly. In addition to or in lieu of the tank head Pressure Sensors 9016, 9018, alternative liquid level sensors or switches may be employed in order to provide a means of identifying whether the tank is above or below a certain point. This may be valuable as a redundant indicator, or to ensure that water was always above the heater element.

[000160] An overflow prevention means may be to add an Overflow Conduit 9022 between the two Reservoirs. This may provide for a more rapid exchange of excess water to the opposite tank than could be done with a passive version of the Tank Level Facilitator 9003.

[000161] Furthermore, Overflow Drains 9023, 9024 may be utilized in order to route excess water to outside the device, (in an overflow tank, or onto the ground). Additional sensors could be added to the Overflow Drains 9023, 9024 to sense this condition, or a means to detect moisture in the overflow tank could be added.

[000162] Parameters for using the system are shown in FIG. 10A–10B.

[000163] Various screens displayed by the touch screen interface are shown in FIGS. 11A–11O. The system can include a controller and/or processor and memory for storing instructions and programming to implement the user interfaces described herein as well as controlling the system as described herein. The various components, such as the pumps, the sensors, the compressors, the heat exchangers, the heaters, and the valves, can be controlled by the processor and/or send information to the processor.

[000164] Thermal Performance Optimization In A Thermal Therapy Device

[000165] Hot and Cold Tank reservoir temperatures may deviate if tank level during therapy, as water fills the heat exchangers and then returns to either the hot tank or cold tank. Particularly during contrast therapy, water is returning to either the hot tank or cold tank. In the current embodiment, water is returned to the tank in which the temperature is closest to avoid unnecessary thermal pollution of excessively hot water entering the cold tank, or excessively cold water from entering the hot tank.

[000166] Over extended therapy times, or with larger heat exchanger volumes, this may lead to a condition where one of the tanks fills up and the other one gets too empty. This problem may be solved by keeping the tanks equalized during therapy by, for instance, pumping water from the higher tank to the lower tank. Or, connecting the tanks with a small diameter tube to allow tanks to equalize over time. This has the disadvantage of brining the emptier tank away from its set temperature, due to the other tank water entering the tank. For instance, if hot water is pumped into the cold tank to increase the tank level, the hot water will increase the temperature in the cold tank. It is not desirable to have therapy temperatures vary excessively away from the set point in this manner.

[000167] Increasing the tank size helps eliminate this condition because if the tank is sufficiently large, there is no worry of getting too full or too empty. However, the larger the tank volume, the longer it takes for reservoir temperatures to reach set point. So excessively large tanks may provide more stable temperature over time and provide plenty of room for large heat

exchangers to be used without the tanks getting too full or too empty, but it may take an unacceptable amount of time for the system to reach desired set point. For instance, with 8 liter tanks, when turning the system on in the morning with the reservoir water at room temperature, it may take 30 minutes to reach set point. When with 4 liter tanks, it may only take 15 minutes to reach set point which is more desirable for the customer.

[000168] To keep the tanks closest to set point, an algorithm has been developed to optimize water temperature during therapy while keeping tank volumes small enough to allow for acceptable cool down and heat up times.

[000169] During therapy, the tanks will not be equalized in order to prevent unnecessary cross tank thermal pollution. However, if the water levels get too low or too full (overflow), preventative steps may be taken: for instance, at a predetermined level, the water returning from the heat exchanger(s) may be diverted to the lower tank instead of the tank of the closest temperature. This is more beneficial than sending water from the opposite tank, as the return water will be closer to the lower tank temperature than the opposite tank. As a further preventative measure, if the tank level gets critically low, cross tank flow may be initiated.

[000170] Similarly, if one tank gets too full, it will begin overflowing into the other tank. This causes thermal pollution in a similar manner as cross tank flow.

[000171] For instance, the water return valves may perform in the following manner:

- If both tank levels exceed 3.75" H₂O AND return temperature is greater than average of hot tank recirculating temp and cold tank recirculating temp by more than 0.5°F then the Hot Tank Return Valve shall be open, otherwise it is closed.
- Open Hot Tank Return valve if the hot tank level is ≤ 3.75 " H₂O
- If hot tank level exceeds 10" H₂O, close hot tank valve until hot tank level drops below 7" H₂O.
- If the Hot tank return valve is closed, then the Cold Tank Return valve shall be open - otherwise it is closed.

[000172] And the tank to tank valves may perform in the following manner:

- Cold tank to hot tank valve:
 - By default the valve between the cold tank to hot tank shall be closed.
 - The valve between the cold tank to hot tank shall perform differently depending on whether Thermal Therapy is active:

- When Thermal Therapy is not active or has not been active for 10 seconds, The valve between the cold tank to hot tank shall be open for 5 seconds and then closed for 5 seconds if the cold tank water level is an absolute delta of 1/4" ($\pm 1/8$ ") greater than the hot tank water level in order to maintain equal tank levels in between therapies.
- When Thermal Therapy is active, the valve between the cold tank to hot tank shall be open for 5 seconds and then closed for 5 seconds if the hot tank level is less than 3.6" H2O AND cold tank level exceeds 3.6" H2O.
- Hot tank to Cold tank valve
 - By default the valve between the hot tank to the cold tank shall be closed.
 - The valve between the hot tank to cold tank shall perform differently depending on whether Thermal Therapy is active:
 - When Thermal Therapy is not active or has not been active for 10 seconds, The valve between the hot tank to cold tank shall be open for 5 seconds and then closed for 5 seconds if the cold tank water level is an absolute delta of 1/4" ($\pm 1/8$ ") greater than the hot tank water level in order to maintain equal tank levels in between therapies.
 - When Thermal Therapy is active, the valve between the hot tank to cold tank shall be open for 5 seconds and then closed for 5 seconds if the hot tank level is less than 3.6" H2O AND cold tank level exceeds 3.6" H2O.

[000173] Once therapies end, there will be a tank equalization period where tanks will equalize, at which point the tank with the lower level will get water added from the tank of the higher level. This will thermally pollute one of the tanks, and some time would be required for the tank to get back to set point.

[000174] Adding a delay mechanism between the end of therapy and the tank equalization period may be desired in case the user wants to use the system right away while the tanks are near their set temperature. The delay could be a fixed period of time (i.e. 10 seconds), or could take the form of a "do not equalize" button.

[000175] A graph of the thermal performance is shown in FIG. 12 and is presented as an example of tank temperatures before and after the enhanced algorithm. The therapy in the example below is a Rapid Contrast Therapy with a straight knee wrap on each port (port 1 and port 2) with 3 minutes on cold, followed by 3 minutes on hot therapy, alternating back and forth for a total of 30 minutes. Two versions of software (containing the algorithms) are presented.

V1.1.6 is the improved algorithm that does not equalize the tanks during therapy. V1.1.5 keeps tanks equalized during therapy to within a certain limit.

[000176] When a feature or element is herein referred to as being “on” another feature or element, it can be directly on the other feature or element or intervening features and/or elements may also be present. In contrast, when a feature or element is referred to as being “directly on” another feature or element, there are no intervening features or elements present. It will also be understood that, when a feature or element is referred to as being “connected”, “attached” or “coupled” to another feature or element, it can be directly connected, attached or coupled to the other feature or element or intervening features or elements may be present. In contrast, when a feature or element is referred to as being “directly connected”, “directly attached” or “directly coupled” to another feature or element, there are no intervening features or elements present. Although described or shown with respect to one embodiment, the features and elements so described or shown can apply to other embodiments. It will also be appreciated by those of skill in the art that references to a structure or feature that is disposed “adjacent” another feature may have portions that overlap or underlie the adjacent feature.

[000177] Terminology used herein is for the purpose of describing particular embodiments only and is not intended to be limiting of the invention. For example, as used herein, the singular forms “a”, “an” and “the” are intended to include the plural forms as well, unless the context clearly indicates otherwise. It will be further understood that the terms “comprises” and/or “comprising,” when used in this specification, specify the presence of stated features, steps, operations, elements, and/or components, but do not preclude the presence or addition of one or more other features, steps, operations, elements, components, and/or groups thereof. As used herein, the term “and/or” includes any and all combinations of one or more of the associated listed items and may be abbreviated as “/”.

[000178] Spatially relative terms, such as “under”, “below”, “lower”, “over”, “upper” and the like, may be used herein for ease of description to describe one element or feature’s relationship to another element(s) or feature(s) as illustrated in the figures. It will be understood that the spatially relative terms are intended to encompass different orientations of the device in use or operation in addition to the orientation depicted in the figures. For example, if a device in the figures is inverted, elements described as “under” or “beneath” other elements or features would then be oriented “over” the other elements or features. Thus, the exemplary term “under” can encompass both an orientation of over and under. The device may be otherwise oriented (rotated 90 degrees or at other orientations) and the spatially relative descriptors used herein interpreted

accordingly. Similarly, the terms “upwardly”, “downwardly”, “vertical”, “horizontal” and the like are used herein for the purpose of explanation only unless specifically indicated otherwise.

[000179] Although the terms “first” and “second” may be used herein to describe various features/elements (including steps), these features/elements should not be limited by these terms, unless the context indicates otherwise. These terms may be used to distinguish one feature/element from another feature/element. Thus, a first feature/element discussed below could be termed a second feature/element, and similarly, a second feature/element discussed below could be termed a first feature/element without departing from the teachings of the present invention.

[000180] Throughout this specification and the claims which follow, unless the context requires otherwise, the word “comprise”, and variations such as “comprises” and “comprising” means various components can be co-jointly employed in the methods and articles (e.g., compositions and apparatuses including device and methods). For example, the term “comprising” will be understood to imply the inclusion of any stated elements or steps but not the exclusion of any other elements or steps.

[000181] As used herein in the specification and claims, including as used in the examples and unless otherwise expressly specified, all numbers may be read as if prefaced by the word “about” or “approximately,” even if the term does not expressly appear. The phrase “about” or “approximately” may be used when describing magnitude and/or position to indicate that the value and/or position described is within a reasonable expected range of values and/or positions. For example, a numeric value may have a value that is +/- 0.1% of the stated value (or range of values), +/- 1% of the stated value (or range of values), +/- 2% of the stated value (or range of values), +/- 5% of the stated value (or range of values), +/- 10% of the stated value (or range of values), etc. Any numerical values given herein should also be understood to include about or approximately that value, unless the context indicates otherwise. For example, if the value “10” is disclosed, then “about 10” is also disclosed. Any numerical range recited herein is intended to include all sub-ranges subsumed therein. It is also understood that when a value is disclosed that “less than or equal to” the value, “greater than or equal to the value” and possible ranges between values are also disclosed, as appropriately understood by the skilled artisan. For example, if the value “X” is disclosed the “less than or equal to X” as well as “greater than or equal to X” (e.g., where X is a numerical value) is also disclosed. It is also understood that the throughout the application, data is provided in a number of different formats, and that this data, represents endpoints and starting points, and ranges for any combination of the data points. For example, if a particular data point “10” and a particular data point “15” are disclosed, it is understood that

greater than, greater than or equal to, less than, less than or equal to, and equal to 10 and 15 are considered disclosed as well as between 10 and 15. It is also understood that each unit between two particular units are also disclosed. For example, if 10 and 15 are disclosed, then 11, 12, 13, and 14 are also disclosed.

[000182] Although various illustrative embodiments are described above, any of a number of changes may be made to various embodiments without departing from the scope of the invention as described by the claims. For example, the order in which various described method steps are performed may often be changed in alternative embodiments, and in other alternative embodiments one or more method steps may be skipped altogether. Optional features of various device and system embodiments may be included in some embodiments and not in others. Therefore, the foregoing description is provided primarily for exemplary purposes and should not be interpreted to limit the scope of the invention as it is set forth in the claims.

[000183] The examples and illustrations included herein show, by way of illustration and not of limitation, specific embodiments in which the subject matter may be practiced. As mentioned, other embodiments may be utilized and derived there from, such that structural and logical substitutions and changes may be made without departing from the scope of this disclosure. Such embodiments of the inventive subject matter may be referred to herein individually or collectively by the term “invention” merely for convenience and without intending to voluntarily limit the scope of this application to any single invention or inventive concept, if more than one is, in fact, disclosed. Thus, although specific embodiments have been illustrated and described herein, any arrangement calculated to achieve the same purpose may be substituted for the specific embodiments shown. This disclosure is intended to cover any and all adaptations or variations of various embodiments. Combinations of the above embodiments, and other embodiments not specifically described herein, will be apparent to those of skill in the art upon reviewing the above description.

CLAIMS

1. A system for providing rapid contrast therapy comprising:
 - a cold reservoir configured to hold a cold liquid;
 - a cold therapy supply valve in fluid communication with the cold reservoir, the cold therapy supply valve directing the flow of the cold liquid to a therapy device;
 - a hot reservoir configured to hold a hot liquid;
 - a hot therapy supply valve in fluid communication with the hot reservoir, the hot therapy supply valve directing the flow of the hot liquid to the therapy; and
 - a return valve directing return flow from the therapy device to at least one of the hot and cold reservoirs; and
 - a controller directing operation of the cold and hot therapy supply valves to control the flow of the cold liquid and the hot liquid to the therapy device, the controller directing operation of the return valve to control the return liquid flowing from the therapy device to at least one of the cold and hot reservoirs.
2. The system of claim 1, further comprising:
 - a first liquid level sensor in the cold reservoir to measure a level of the cold liquid; a second liquid level sensor in the hot reservoir to measure a level of the hot liquid;
 - a first temperature sensor to measure a temperature of the cold liquid;
 - a second temperature sensor to measure a temperature of the hot liquid; and
 - a return temperature sensor for measuring a temperature of the return flow from the therapy device.
3. The system of any one of claims 1–2, wherein the first temperature sensor is provided in cold liquid recirculation manifold and the second temperature sensor is provided in the hot liquid recirculation manifold.
4. The system of any one of claims 1–3, wherein the first temperature sensor is provided in the cold liquid reservoir and the second temperature sensor is provided in the hot liquid reservoir.
5. The system of any one of claims 1–4, wherein the controller directs return flow from the therapy device to at least one of the cold and hot reservoirs after determining that the measured liquid level within each of the cold and hot reservoirs is within a target liquid level range,
 - wherein the controller directs the return flow to either the cold reservoir or the hot reservoir depending on the temperature of the return flow such that the return flow is directed to

the reservoir containing the liquid having a closest temperature with the temperature of the return flow.

6. The system of any one of claims 1–5, wherein the controller directs return flow from the therapy device to at least one of the cold and hot reservoirs after determining that the measured liquid level within each of the cold and hot reservoirs is within a target liquid level range,

wherein the controller directs the return flow to the hot reservoir when the temperature of the return flow is greater than an average of the temperatures of cold and hot liquids.

7. The system of any one of claims 1–6, wherein the controller directs return flow from the therapy device to at least one of the cold and hot reservoirs after determining that the measured liquid level within each of the cold and hot reservoirs is within a target liquid level range,

wherein the controller directs the return flow to the hot reservoir when the temperature of the return flow is greater than an average of the temperatures of cold and hot liquids by more than a predetermined offset amount.

8. The system of claim 7, wherein the predetermined offset amount is 0.5°F.

9. The system of any one of claims 1–8, wherein the controller directs return flow from the therapy device to at least one of the cold and hot reservoirs after determining that the measured liquid level within each of the cold and hot reservoirs is within a target liquid level range,

wherein controller directs return flow to the hot reservoir when the temperature of the return flow is equal to or greater than the temperature of the hot liquid in the hot reservoir.

10. The system of any one of claims 1–9, wherein the controller directs return flow from the therapy device to at least one of the cold and hot reservoirs after determining that the measured liquid level within each of the cold and hot reservoirs is within a target liquid level range,

wherein controller directs the return flow to the hot reservoir when the temperature of the return flow is greater than the temperature of the cold liquid in the cold reservoir.

11. The system of any one of claims 1–10, wherein the controller directs return flow from the therapy device to at least one of the cold and hot reservoirs after determining that the measured liquid level within each of the cold and hot reservoirs is within a target liquid level range,

wherein the controller directs the return flow to the hot reservoir when the temperature of the return flow is greater than a maximum cold reservoir return temperature.

12. The system of claim 11, wherein the maximum cold reservoir return temperature corresponds to the temperature of the cold liquid in the cold reservoir (measured in °F) plus an offset amount,

wherein the offset amount is 0.5 °F.

13. The system of any one of claims 1–12, wherein the controller directs the return flow to either the cold reservoir or the hot reservoir depending on the measured liquid level in each of the cold and hot reservoirs such that the measured liquid level in the cold and hot reservoirs does not exceed the corresponding maximum liquid level or fall below the corresponding minimum liquid level,

wherein the controller directs the return flow to the cold reservoir when the first liquid level sensor measures a liquid level below the minimum liquid level for the cold reservoir.

14. The system of claim 13, wherein the controller directs the return flow to the hot reservoir when the second liquid level sensor measures a liquid level below the minimum liquid level for the hot reservoir.

15. The system of any one of claims 13–14, wherein the controller directs return flow to the hot reservoir when the first liquid level sensor measures a liquid level above a maximum liquid level for the cold reservoir, and

wherein the controller directs return flow to the cold reservoir when the second liquid level sensor measures a liquid level above the maximum liquid level for the hot reservoir.

16. The system of any one of claims 13–15, wherein the minimum liquid level of the cold and hot reservoirs is 62% of a full operating liquid level of the corresponding cold and hot reservoir.

17. The system of any one of claims 13–16, wherein the minimum liquid level of the cold and hot reservoirs is 75% of a full operating liquid level of the corresponding cold and hot reservoir.

18. The system of any one of claims 13–17, wherein the minimum liquid level of the cold and hot reservoirs is 3.75”.

19. The system of claim 18, wherein the full operating liquid level of the cold and hot reservoir ranges between 5–6”.

20. The system of any one of claims 13–17, wherein the minimum liquid level of the cold and hot reservoirs is 3.6”.

21. The system of claim 20, wherein the full operating liquid level of the cold and hot reservoir ranges between 5–6”.

22. The system of any one of claims 13–21, wherein the maximum liquid level of the cold and hot reservoirs corresponds to a liquid level where the cold and hot reservoirs indicate an overflow condition.

23. The system of claim 22, wherein the maximum liquid level of the cold and hot reservoirs is greater than 100% of a full operating liquid level of the corresponding cold and hot reservoir.

24. The system of claim 23, wherein the maximum liquid level of the cold and hot reservoirs greater than 7”.

25. The system of any one of claims 23–24, wherein the full operating liquid level of the corresponding cold and hot reservoir ranges between 5–6”.

26. The system of any one of claims 1–25, further comprising
one or more conduits extending between the cold reservoir and the hot reservoir, the conduit providing fluid communication therebetween; and
one or more cross-tank valves for controlling flow through the conduit;
wherein the controller directs operation of the one or more cross-tank valves to control flow between the cold and hot reservoirs,

wherein the controller directs operation of the one or more cross-tank valves in response to the measured liquid level in each of the cold and hot reservoirs such that the liquid level in either the cold and hot reservoirs does not exceed a maximum liquid level or fall below a minimum liquid level.

27. The system of claim 26, wherein the one or more cross-tank valves of the conduit is biased in a closed position.

28. The system of any one of claims 26–27, further comprising a pump for moving liquid through the conduit.

29. The system of any one of claims 26–28, wherein the conduit is connected to a recirculation pump for moving fluid through the conduit between the cold and hot reservoirs.

30. The system of any one of claims 26–29, wherein the minimum liquid level of the cold and hot reservoirs is 60% of a full operating liquid level of the corresponding cold and hot reservoir.

31. The system of any one of claims 26–30, wherein the minimum liquid level of the cold and hot reservoirs is 72% of a full operating liquid level of the corresponding cold and hot reservoirs.

32. The system of any one of claims 26–31, wherein the minimum liquid level of the cold and hot reservoirs is 3.75”.

33. The system of claim 32, wherein the full operating liquid level of the cold and hot reservoir ranges between 5–6”.

34. The system of any one of claims 26–31, wherein the minimum liquid level is 3.6”.

35. The system of claim 34, wherein the full operating liquid level of the cold and hot reservoir ranges between 5–6”.

36. The system of any one of claims 26–35, wherein controller directs flow through the conduit from the hot reservoir to the cold reservoir when the first liquid level sensor measures a liquid level below the minimum liquid level for the cold reservoir,

wherein the controller directs flow through the conduit from the cold reservoir to the hot reservoir when the second liquid level sensor measures a liquid level below the minimum liquid level for the hot reservoir.

37. The system of any one of claims 26–36, wherein controller directs flow through the conduit from the cold reservoir to the hot reservoir when the first liquid level sensor measures a liquid level above the maximum liquid level for the cold reservoir,

wherein controller directs flow through the conduit from the hot reservoir to the cold reservoir when the second liquid level sensor measures a liquid level above the maximum liquid level for the hot reservoir.

38. The system of any one of claims 26–37, wherein during operation at least one of the cold and hot liquids is provided to a therapy device and the return flow is received from the therapy device and directed to the cold or hot reservoirs,

wherein, during operation the controller directs operation of the cross-tank valve to open fluid communication between the reservoirs for a first time period.

39. The system of claim 38, wherein the controller directs cycled operation of the cross-tank valve to open and close fluid communication between the reservoirs, such that during each open-close cycle the cross-tank valve is open for the first time period and closed for a second time period until the difference between the measured liquid levels in the cold and hot reservoirs is within a predetermined deviation amount.

40. The system of claim 39, wherein the first time period is 5 seconds and the second time period is 5 seconds.

41. The system of any one of claims 39–40, wherein the minimum liquid level of the cold and hot reservoirs corresponds to a liquid level where the cold and hot reservoirs indicate a critically low operating condition.

42. The system of any one of claims 39–41, wherein the predetermined deviation amount is $1/4'' \pm 1/8''$.

43. The system of any one of claims 26–42, wherein the system is not operating when at least one of the cold and hot liquids have not been provided to the therapy device for a predetermined off period,

wherein, when the system is not operating, the controller directs operation of the cross-tank valve to open fluid communication between the reservoirs for a first time period.

44. The system of claim 43, wherein the predetermined off period that the therapy system is not operating is less than or equal to 20 seconds.

45. The system of any one of claims 43–44, wherein the predetermined off period that the therapy system is not operating is at least 5 second.

46. The system of any one of claims 43–45, wherein the controller directs operation of the cross-tank valve to open fluid communication between the reservoirs until the difference between the measured liquid levels in the cold and hot reservoirs is within a predetermined deviation amount.

47. The system of claim 46, wherein the predetermined deviation amount is $1/4'' \pm 1/8''$.

48. The system of claim 43, wherein the controller directs cycled operation of the cross-tank valve to open and close fluid communication between the reservoirs, such that during each open-close cycle the cross-tank valve is open for the first time period and closed for a second time period until the difference between the measured liquid levels in the cold and hot reservoirs is within a predetermined deviation amount.

49. The system of claim 48, wherein the first time period is 5 seconds and the second time period is 5 seconds.

50. The system of any one of claims 48–49, wherein the predetermined deviation amount is $1/4'' \pm 1/8''$.

51. The system of any one of claims 1–50, wherein the return valve comprises a cold reservoir return valve and a hot reservoir return valve,

wherein the cold reservoir return valve directs return flow from the therapy device to the cold reservoir,

wherein the hot reservoir return valve directs return flow from the therapy device to the hot reservoir.

52. The system of any one of claims 1–51, wherein at least one of the cold therapy supply valve, the hot therapy supply valve, the return valve and the cross-tank valve can be adjusted by the controller to vary at least one of a flow rate, volume, flow pressure, and temperature of the flow of liquid therethrough.

53. The system of any one of claims 1–52, wherein the return temperature sensor is provided upstream of the return valve such that the return temperature sensor is between an output of the therapy device and the return valve.

54. The system of any one of claims 1–53, wherein the therapy device comprises a therapy wrap configured for wrapping to a portion of an animate body for delivering treatment.

55. The system of any one of claims 1–54, wherein the cold reservoir includes a cold reservoir fill port and the hot reservoir includes a hot reservoir fill port,

wherein the cold and hot reservoir fill ports are housed in a receptacle that is configured to accommodate fluid overflow from the cold reservoir and the hot reservoir by allowing the cold liquid to overflow from the cold reservoir and into the hot reservoir or the hot liquid to overflow from the hot reservoir and into the cold reservoir.

56. The system of any one of claims 1–55, further comprising:
a first pump configured to pump cold liquid from the cold reservoir to the therapy device;
and
a second pump configured to pump hot liquid from the hot reservoir to the therapy device.

57. The system of any one of claims 1–56, further comprising:
a chiller configured to cool the cold liquid, and
a third pump (recirculating pump) configured to pump the cold liquid from the cold reservoir to the chiller.

58. The system of claim 57, wherein the third pump (recirculating pump) is configured to pump cold liquid to the hot reservoir.

59. The system of any one of claims 57–58, wherein the third pump is located upstream of the first pump.

60. The system of any one of claims 57–59, wherein the cold therapy supply valve is located downstream from the first pump

61. The system of any one of claims 1–60, further comprising:
a heater configured to heat the hot liquid; and
a fourth pump (recirculating pump) configured to pump the hot liquid from the hot reservoir to the heater.

62. The system of claim 61, wherein the heater is disposed in the hot reservoir.

63. The system of any one of claims 61–62, further comprising:
a heater baffle disposed proximate the heater, wherein the heater baffle is configured to induce convection of the hot liquid around the heater.

64. The system of any one of claims 61–63, wherein the fourth pump (recirculating pump) is configured to pump hot liquid to the cold reservoir.

65. The system of any one of claims 61–64, wherein the fourth pump is located upstream of the second pump.

66. The system of claim 65, wherein the hot therapy supply valve is located downstream from the second pump.

67. The system of any one of claims 1–66, further comprising:
a first pressure sensor located on the bottom of the cold reservoir, and
a second pressure sensor located on the bottom of the hot reservoir.

68. The system of any one of claims 1–67, further comprising:
a heating element disposed in the cold reservoir.

69. The system of any one of claims 1–68, further comprising:
an overflow conduit extending from an upper portion of the cold reservoir to an upper portion of the hot reservoir,
wherein the overflow conduit provides fluid communication between the cold reservoir and the hot reservoir.

70. The system of any one of claims 1–69, further comprising:
a compressor configured to pressurize the therapy device.

71. The system of any one of claims 56–70, further comprising:
a user interface configured to allow a user to set one or more parameters of the rapid contrast therapy; and
wherein the controller operates at least one of a chiller, a heater, the first pump, and the second pump based on the parameters selected by the user using the user interface.

72. A method of providing rapid contrast therapy using the rapid contrast therapy device of claims 1–71, the method comprising:
applying a therapy wrap to a patient;
connecting a therapy wrap connector to a treatment device connector, the therapy device connector providing fluid communication between the therapy wrap and a cold therapy supply line, a hot therapy supply line and a pressurized gas supply line;
measuring a liquid level of a cold and hot liquid within a cold and hot liquid reservoir provided in the therapy device;
confirming a measured liquid level within each of the cold and hot reservoirs is within a target liquid level range;

providing at least one of a temperature therapy and a pressure therapy to the patient via the therapy wrap by directing at least one of a cold liquid, a hot liquid and a pressurized gas through therapy wrap via a corresponding cold therapy supply valve, hot therapy supply valve and gas therapy supply valve;

controlling via a return valve a return flow of the liquid from the therapy wrap to at least one of the cold and hot reservoirs to minimize the unnecessary thermal pollution of hot water from entering the cold tank or cold water from entering the hot tank upon return from the therapy wrap.

73. The method of claim 72, wherein the return flow is directed to either the cold reservoir or the hot reservoir depending on the temperature of the return flow such that the return flow is directed to the reservoir containing the liquid having a closest temperature with the temperature of the return flow.

74. The method of any one of claims 72–73, wherein the return flow is directed to the hot reservoir when the temperature of the return flow is greater than an average of the temperatures of cold and hot liquids.

75. The method of any one of claims 72–74, wherein the return flow is directed to the hot reservoir when the temperature of the return flow is greater than an average of the temperatures of cold and hot liquids by more than a predetermined offset amount.

76. The method of claim 75, wherein the predetermined offset amount is 0.5°F.

77. The method of any one of claims 72–76, wherein the return flow is directed to the hot reservoir when the temperature of the return flow is equal to or greater than the temperature of the hot liquid in the hot reservoir.

78. The method of any one of claims 72–77, wherein the return flow is directed to the hot reservoir when the temperature of the return flow is greater than the temperature of the cold liquid in the cold reservoir.

79. The method of any one of claims 72–78, wherein the return flow is directed to the hot reservoir when the temperature of the return flow is greater than a maximum cold reservoir return temperature.

80. The method of claim 79, wherein the maximum cold reservoir return temperature corresponds to the temperature of the cold liquid in the cold reservoir (measured in °F) plus an offset amount,

wherein the offset amount is 0.5 °F.

81. The method of any one of claims 72–80, wherein the measured liquid level within either of the cold and hot reservoirs is not within a target liquid level range the return flow is

directed to either the cold reservoir or the hot reservoir depending on the measured liquid level in each of the cold and hot reservoirs such that the measured liquid level in the cold and hot reservoirs does not exceed the corresponding maximum liquid level or fall below the corresponding minimum liquid level.

82. The method of claim 81, wherein the return flow is directed to the cold reservoir when the first liquid level sensor measures a liquid level below the minimum liquid level for the cold reservoir, and

wherein the return flow is directed to the hot reservoir when the second liquid level sensor measures a liquid level below the minimum liquid level for the hot reservoir.

83. The method of any one of claims 81–82, wherein the return flow is directed to the hot reservoir when the first liquid level sensor measures a liquid level above a maximum liquid level for the cold reservoir, and

wherein return flow is directed to the cold reservoir when the second liquid level sensor measures a liquid level above the maximum liquid level for the hot reservoir.

84. The method of any one of claims 72–83, further comprising:

directing a cross-tank flow of the cold and hot liquids between the cold and hot reservoirs via a conduit operated by a cross-tank valve, where the cross-tank flow is directed in response to the measured liquid levels in each of the cold and hot reservoirs such that the liquid level in either the cold and hot reservoirs does not exceed a maximum liquid level or fall below a minimum liquid level.

85. The method of claim 84, further comprising:

directing flow through the conduit from the hot reservoir to the cold reservoir when the first liquid level sensor measures a liquid level below the minimum liquid level for the cold reservoir.

86. The method of any one of claims 84–85, further comprising

directing flow through the conduit from the cold reservoir to the hot reservoir when the second liquid level sensor measures a liquid level below the minimum liquid level for the hot reservoir.

87. The method of any one of claims 84–86, further comprising directing flow through the conduit from the cold reservoir to the hot reservoir when the first liquid level sensor measures a liquid level above the maximum liquid level for the cold reservoir.

88. The method of any one of claims 84–87, further comprising directing flow through the conduit from the hot reservoir to the cold reservoir when the second liquid level sensor measures a liquid level above the maximum liquid level for the hot reservoir.

89. The method of any one of claims 84–88, wherein during operation of the therapy device at least one of the cold and hot liquids is provided to the therapy wrap and the return flow is received from the therapy wrap and directed to the cold or hot reservoirs,

during operation of the therapy device, directing operation of the cross-tank valve to open fluid communication between the reservoirs for a first time period.

90. The method of claim 89, further comprising:

directing cycled operation of the cross-tank valve to open and close fluid communication between the reservoirs, such that during each open-close cycle the cross-tank valve is open for the first time period and closed for a second time period until the difference between the measured liquid levels in the cold and hot reservoirs is within a predetermined deviation amount.

91. The method of any one of claims 89–90, wherein the minimum liquid level of the cold and hot reservoirs corresponds to a liquid level where the cold and hot reservoirs indicate a critically low operating condition.

92. The method of any one of claims 84–91, wherein the therapy device is not operating when at least one of the cold and hot liquids have not been provided to the therapy wrap for a predetermined off period,

when the therapy device is not operating, directing operation of the cross-tank valve to open fluid communication between the reservoirs for a first time period.

93. The method of claim 92, further comprising:

directing cycled operation of the cross-tank valve to open and close fluid communication between the reservoirs, such that during each open-close cycle the cross-tank valve is open for the first time period and closed for a second time period until the difference between the measured liquid levels in the cold and hot reservoirs is within a predetermined deviation amount.

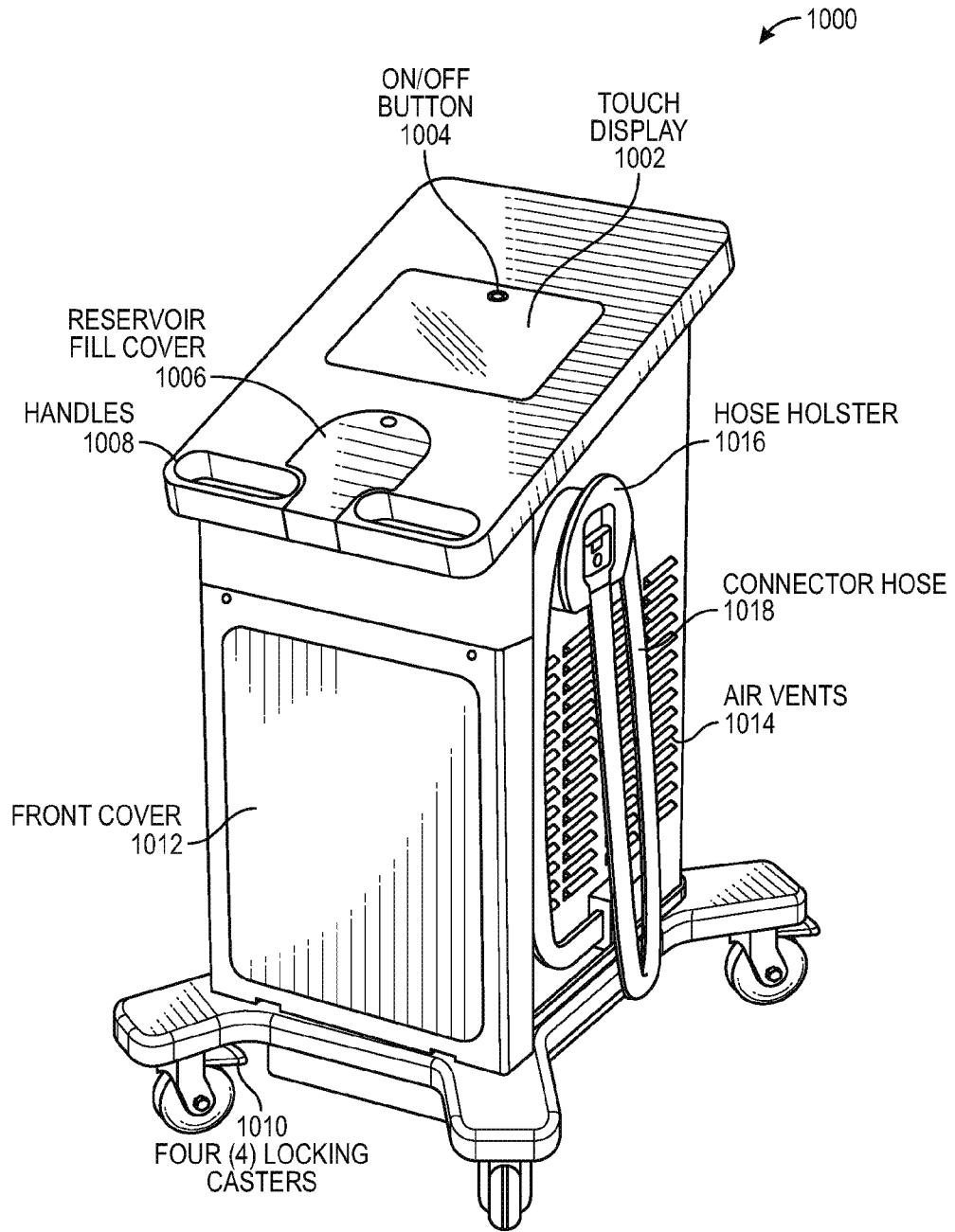

FRONT VIEW

FIG. 1A

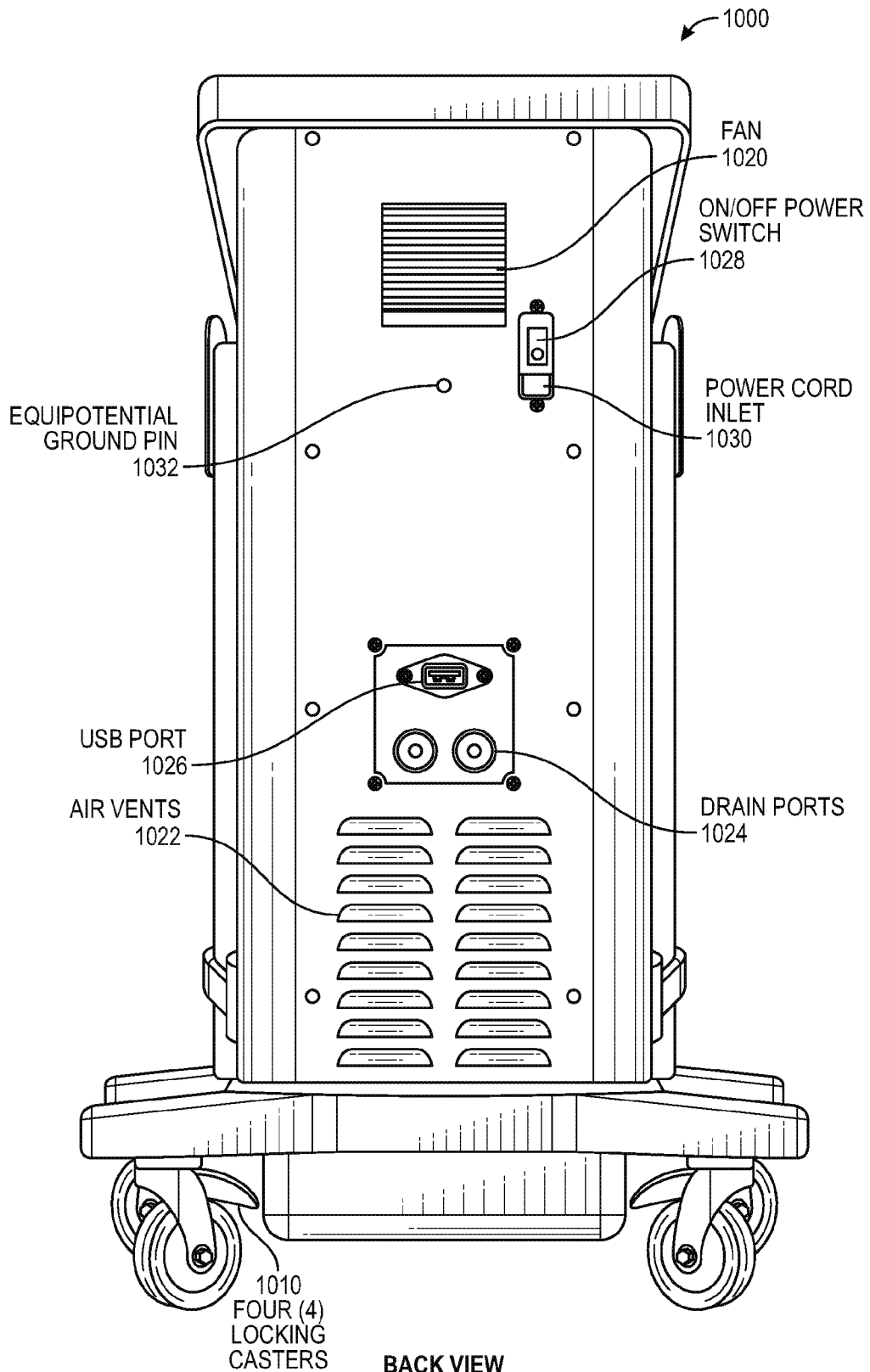

2000 →

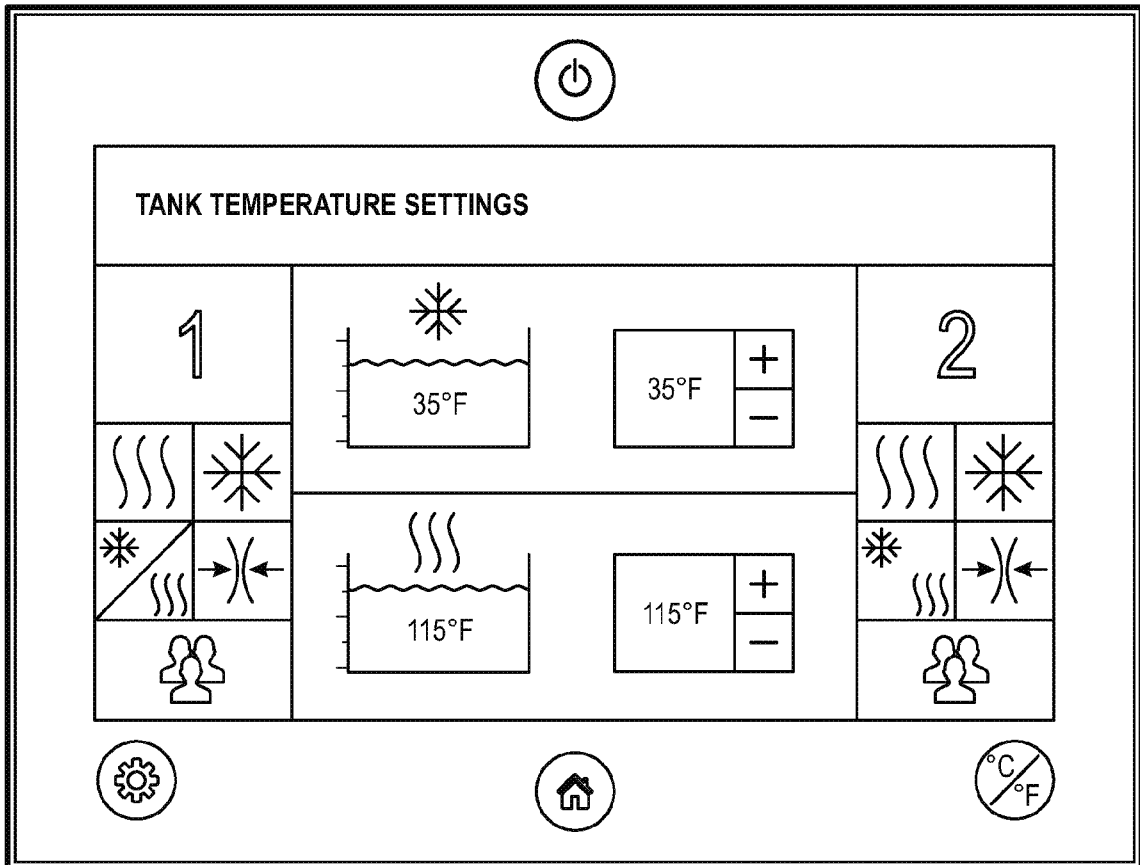

FIG. 2

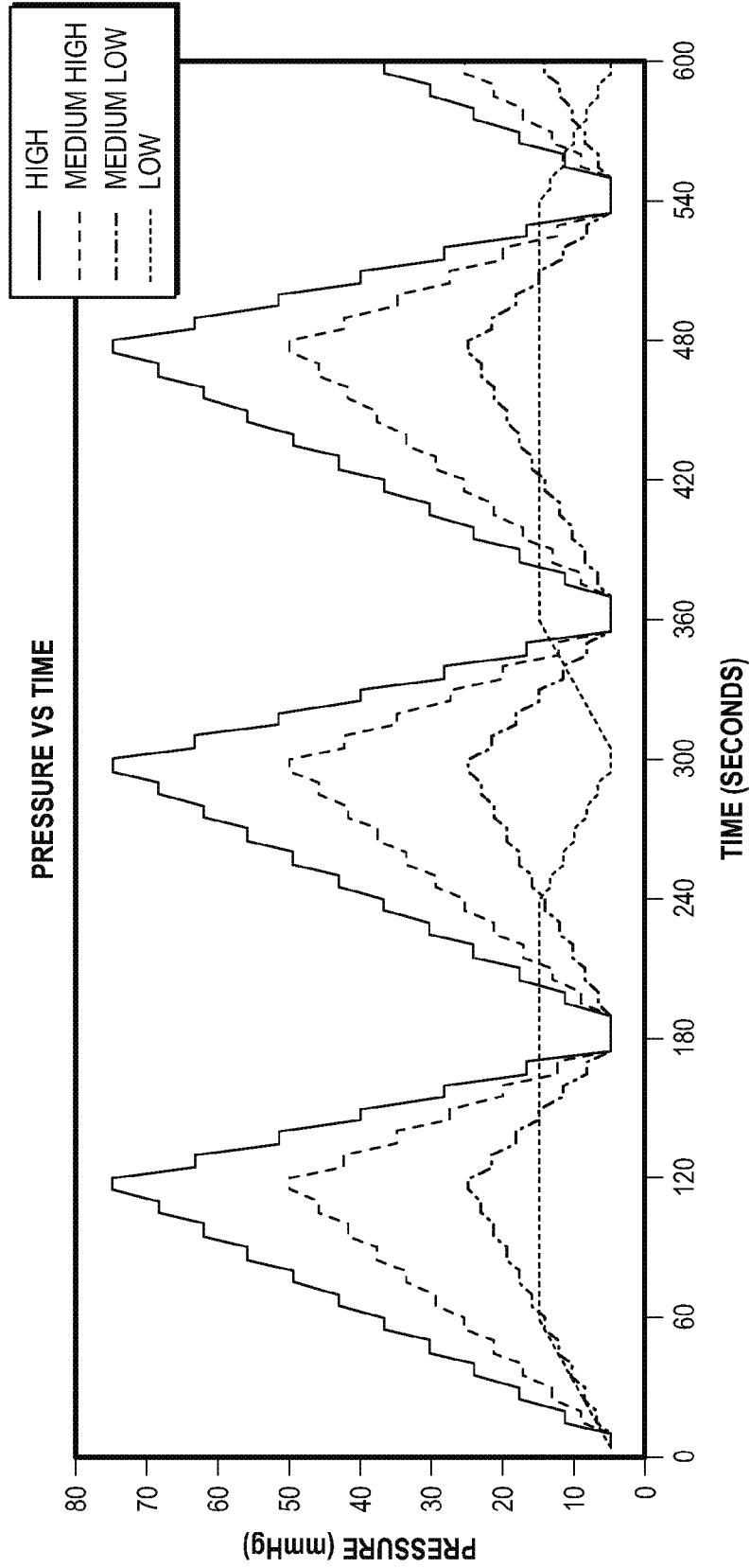

FIG. 3

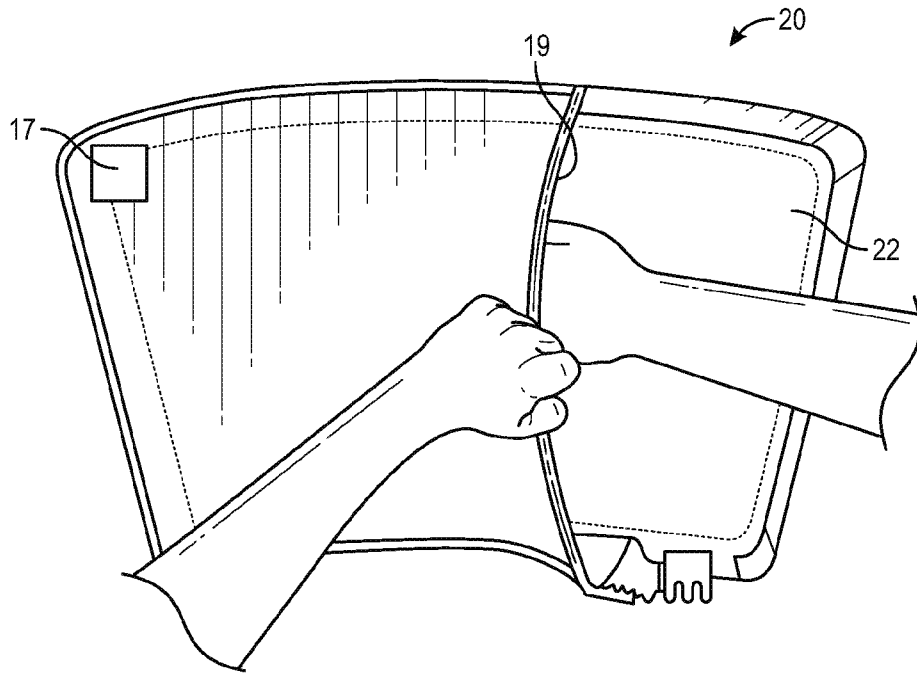

FIG. 4A

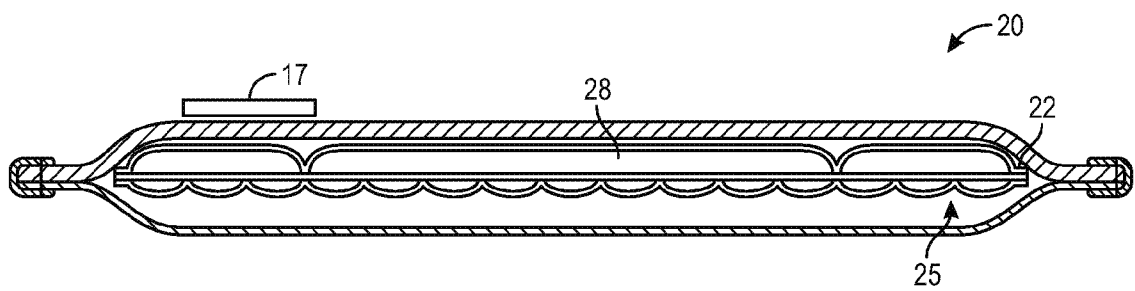

FIG. 4B

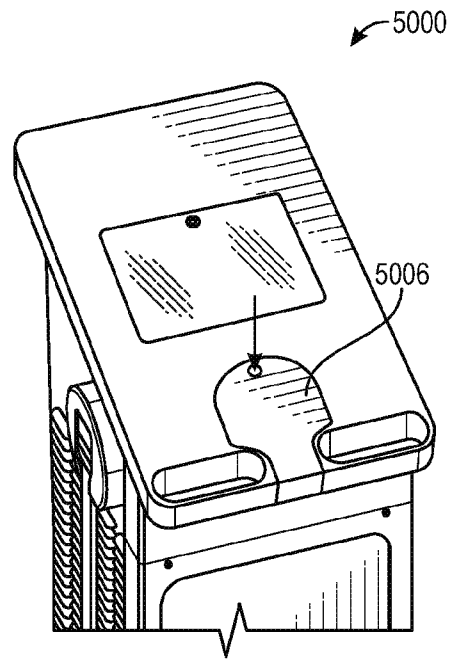

FIG. 5A

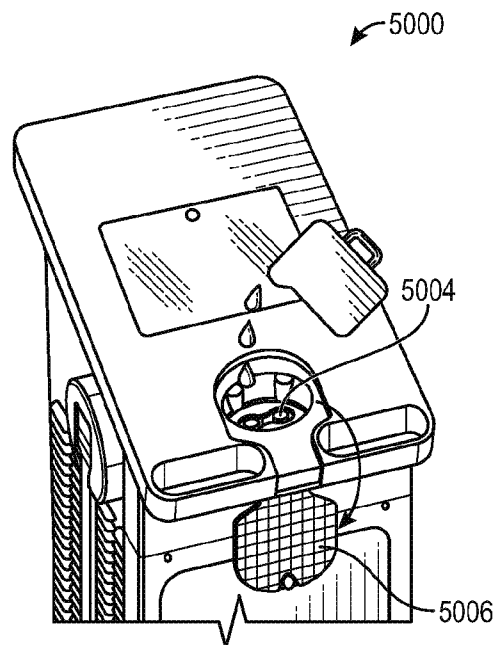

FIG. 5B

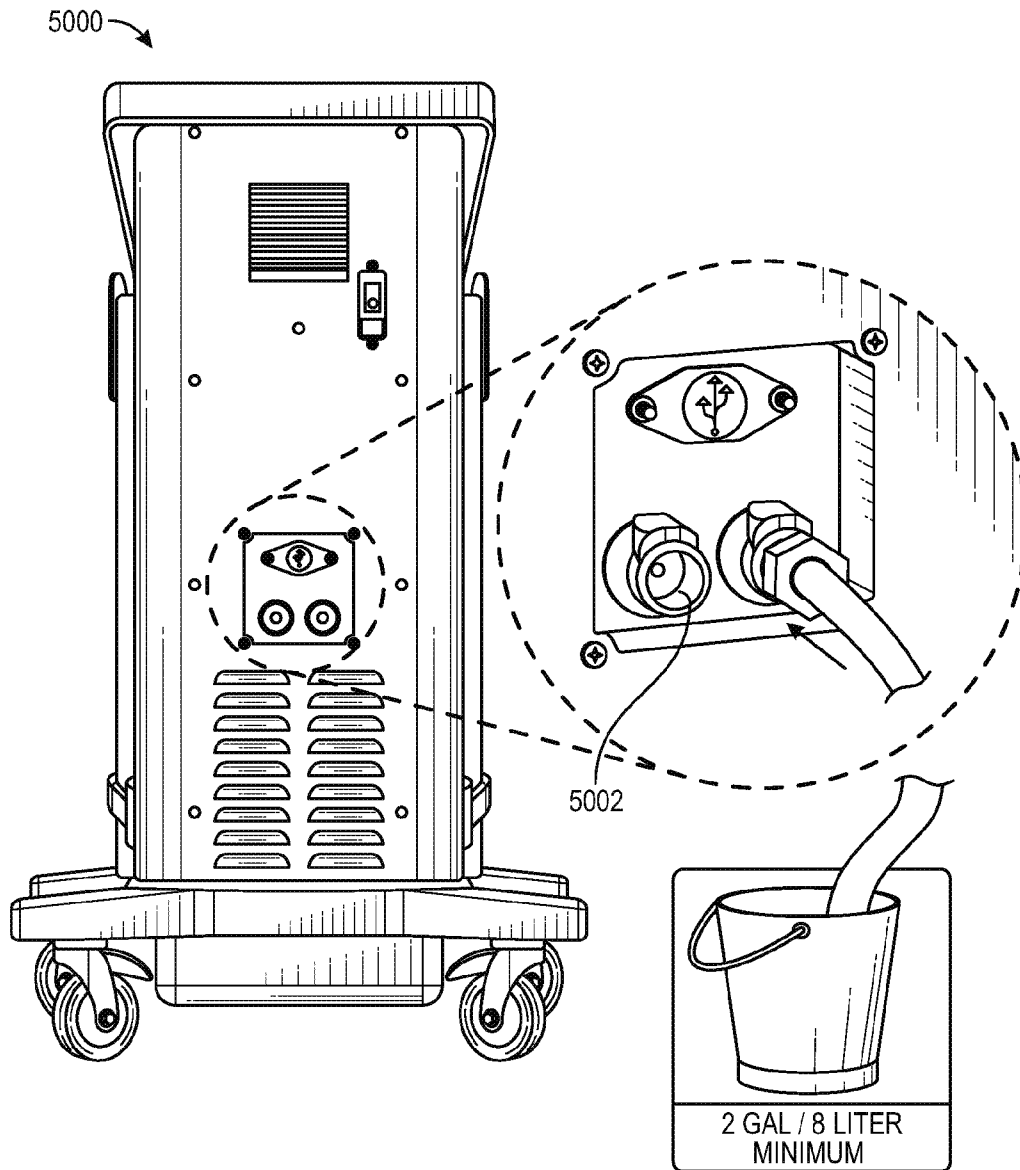

FIG. 5C

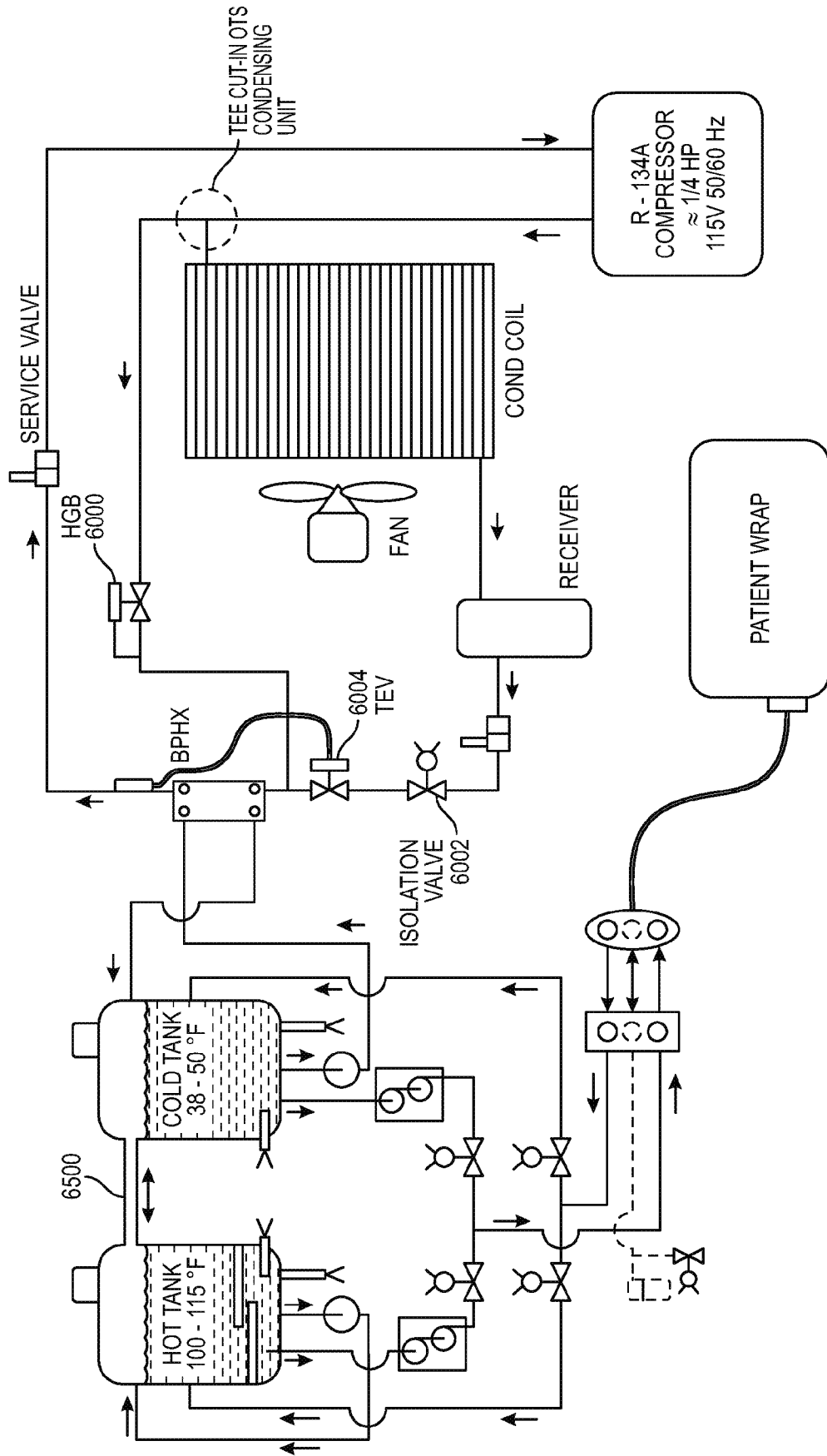

FIG. 6

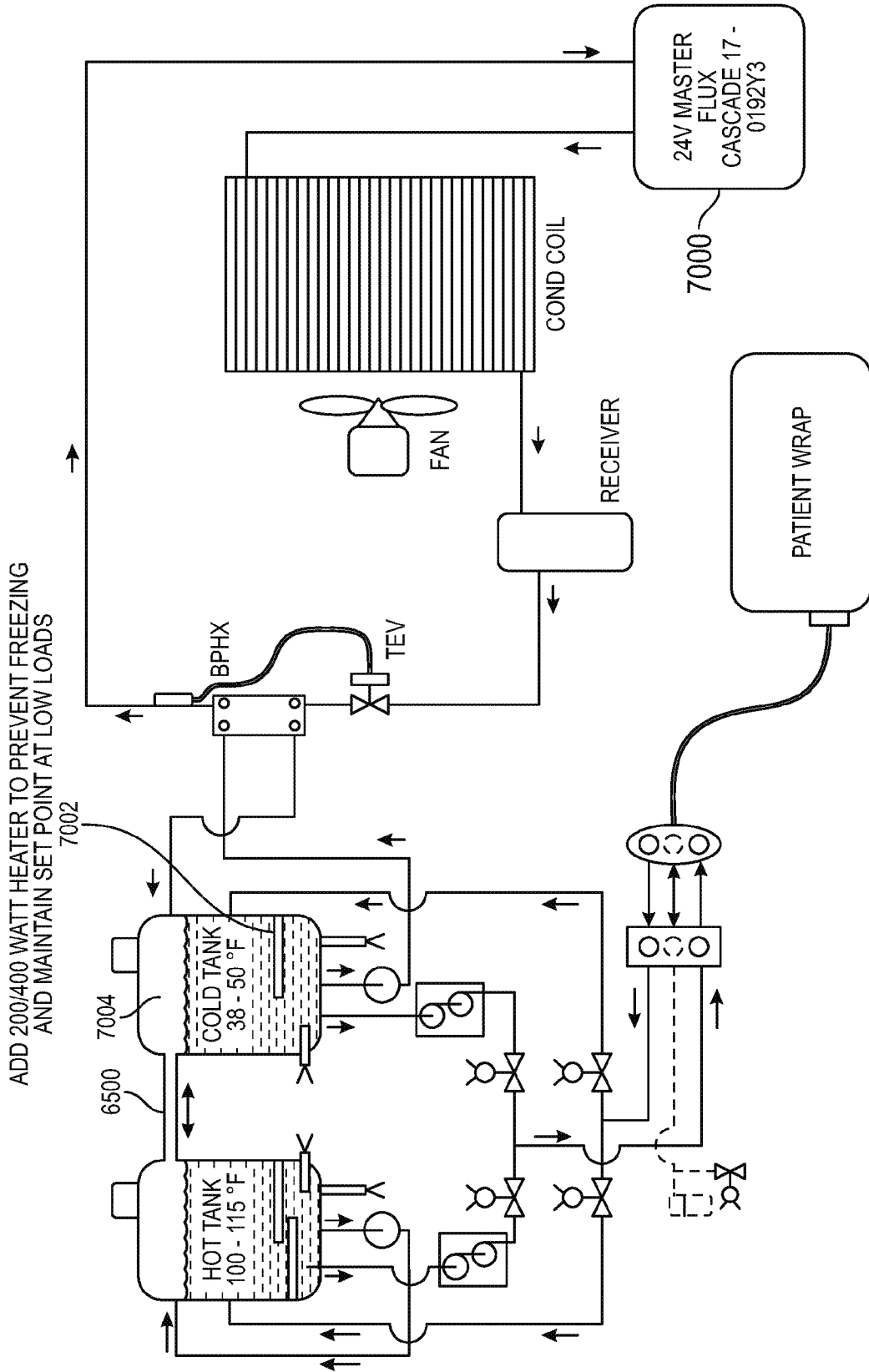

FIG. 7

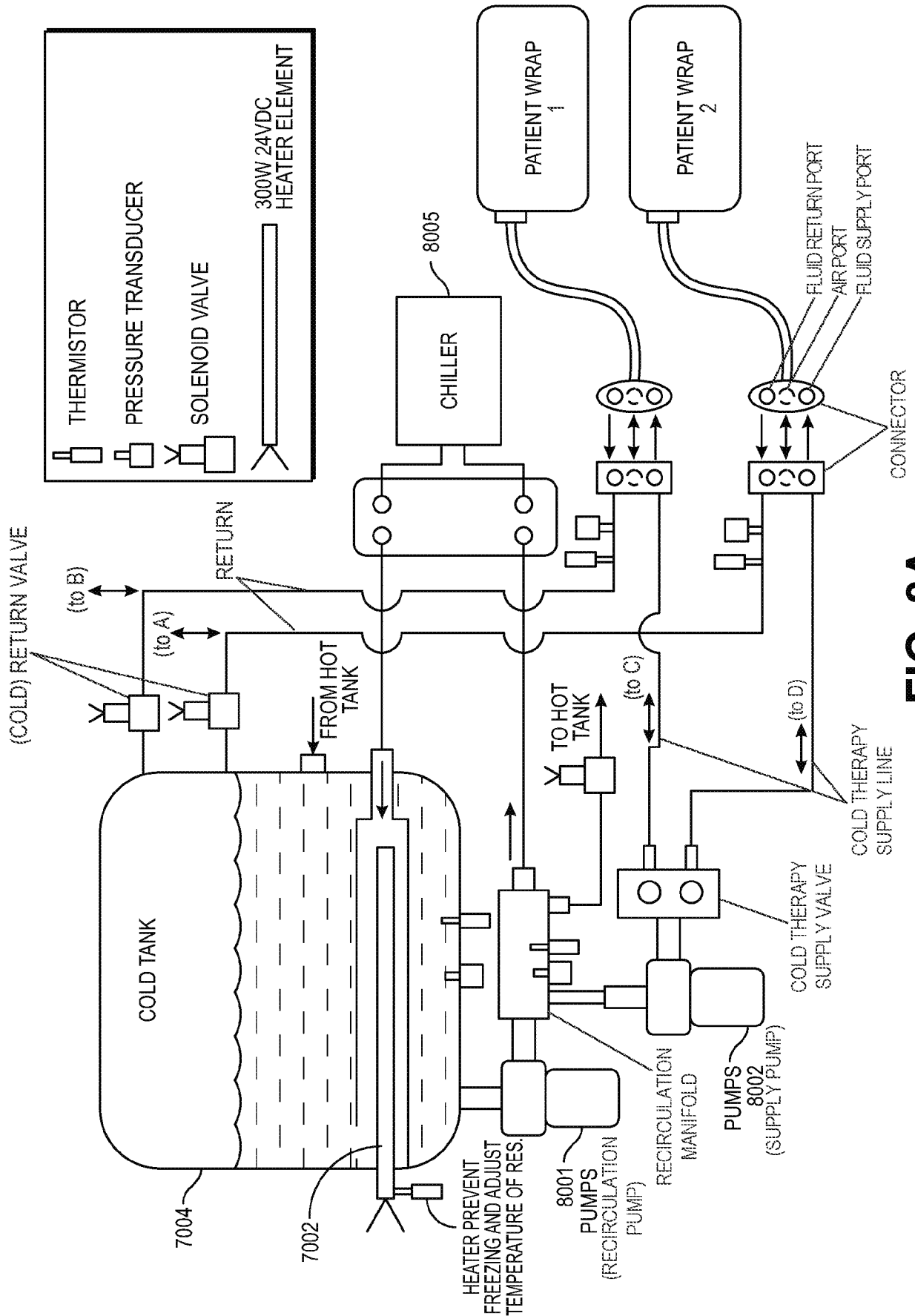

FIG. 8A

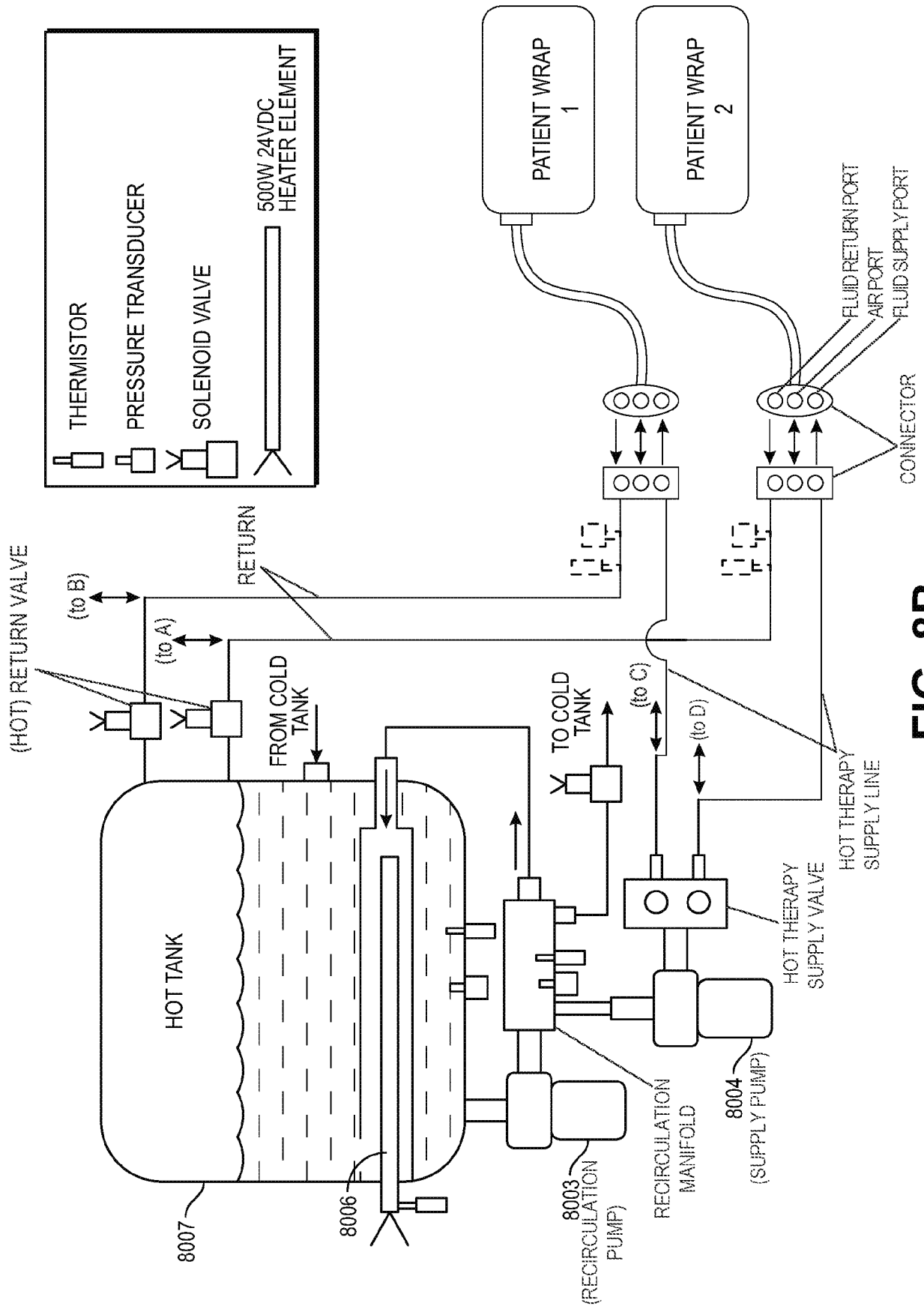

FIG. 8B

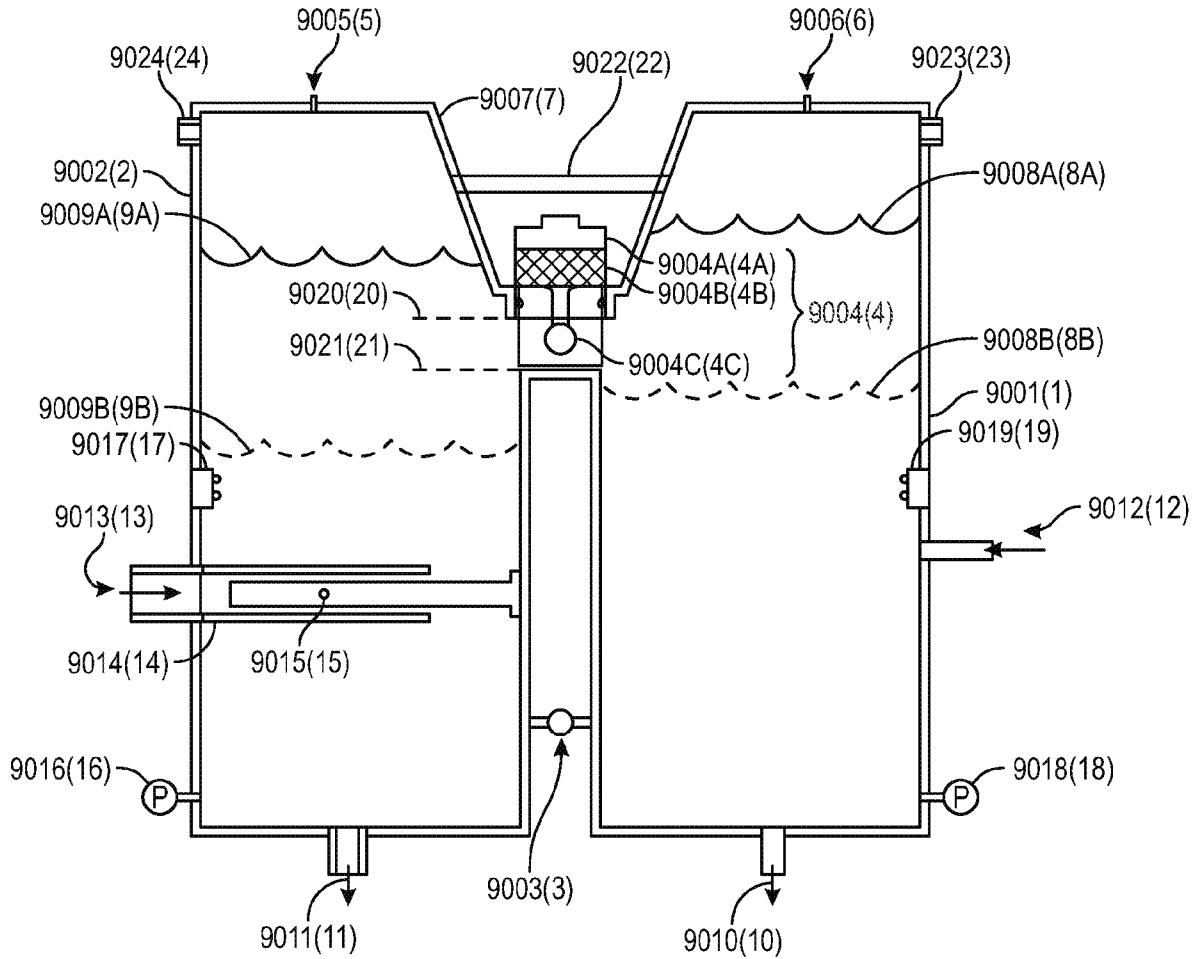

FIG. 9A

ITEM #	DESCRIPTION
<u>9001</u>	COLD RESERVOIR
<u>9002</u>	HOT RESERVOIR
<u>9003</u>	TANK LEVEL FACILITATOR
<u>9004</u>	FILL CAP
<u>9004A</u>	KNOB
<u>9004B</u>	STRAINER
<u>9004C</u>	TANK SEAL
<u>9005</u>	HOT RESERVOIR VENT
<u>9006</u>	COLD RESERVOIR VENT
<u>9007</u>	FILL PORT
<u>9008</u>	COLD WATER LEVEL
<u>9009</u>	HOT WATER LEVEL
<u>9010</u>	COLD WATER OUTLET
<u>9011</u>	HOT WATER OUTLET
<u>9012</u>	COLD WATER INLET
<u>9013</u>	HOT WATER INLET
<u>9014</u>	HEATER BAFFLE
<u>9015</u>	HEATER
<u>9016</u>	HOT RESERVOIR PRESSURE SENSOR
<u>9017</u>	HOT RESERVOIR LOW LEVEL SENSOR
<u>9018</u>	COLD RESERVOIR PRESSURE SENSOR
<u>9019</u>	COLD RESERVOIR LOW LEVEL SENSOR
<u>9020</u>	UPPER FILL LEVEL
<u>9021</u>	LOWER FILL LEVEL
<u>9022</u>	OVERFLOW CONDUIT
<u>9023</u>	COLD RESERVOIR OVERFLOW DRAIN
<u>9024</u>	HOT RESERVOIR OVERFLOW DRAIN

FIG. 9B

OTHER FEATURES	COMPRESSION LEVEL* (INTERMITTENT PNEUMATIC)	TREATMENT TIME	TEMPERATURE LEVELS	THERAPY UP TO 2 PATIENTS
—	LOW & NONE	SET TOTAL THERAPY TIME	SET MINIMUM AND MAXIMUM, IN °FOR °C	HEAT
SNOOZE FEATURE, UP TO 6 CYCLES	LOW, MEDIUM - LOW MEDIUM, HIGH & NONE	SET TOTAL THERAPY TIME	SET MINIMUM AND MAXIMUM, IN °FOR °C	COLD
START RAPID CONTRAST THERAPY WITH EITHER HEAT OR COLD THERAPY	HEAT: LOW & NONE COLD: LOW, MEDIUM - LOW, MEDIUM, HIGH & NONE	SET HEAT AND COLD CYCLE TIME AND TOTAL THERAPY TIME	SET HEAT AND COLD MINIMUM AND MAXIMUM, IN °FOR °C	RAPID CONTRAST
—	LOW, MEDIUM - LOW MEDIUM, HIGH	SET TOTAL THERAPY TIME	—	COMPRESSION-ONLY

*COMPRESSION LEVELS :

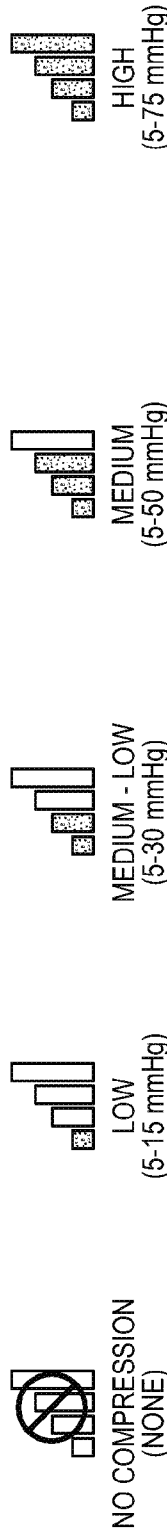

HEAT RESERVOIR TEMPERATURE RANGE	95 - 113°F (35-45°C)
COLD RESERVOIR TEMPERATURE RANGE	38 - 60°F (3.33 - 15-56°C)
CAPACITIES	HEAT RESERVOIR: 1 GALLON (3.79 LITERS) COLD RESERVOIR: 1 GALLON (3.79 LITERS)
RESERVOIR TEMPERATURE:	MAXIMUM HEAT RESERVOIR TEMPERATURE: 113°F (45°C) MAXIMUM COLD RESERVOIR TEMPERATURE: 38°F (3°C) TOLERANCE: ±4°F (2°C)

FIG. 10A











FACTORY DEFAULT SETTINGS			
	MINIMUM SETTING	DEFAULT SETTING	MAXIMUM SETTING
RESERVOIR TEMPERATURE			
 HEAT	96°F / 35°C	105°F / 41°C	113°F / 45°C
 COLD	38°F / 3°C	40°F / 4°C	55°F / 13°C
HEAT THERAPY			
 COMPRESSION LEVEL	NONE	LOW	LOW
 TREATMENT TIME	5 MINUTES	15 MINUTES	30 MINUTES
COLD THERAPY			
 COMPRESSION LEVEL	NONE	LOW	HIGH
 TREATMENT TIME	5 MINUTES	15 MINUTES	60 MINUTES
 SNOOZE	DISABLED	DISABLED	ENABLED
 SNOOZE DURATION	30 MINUTES	30 MINUTES	60 MINUTES
 NUMBER OF SNOOZE CYCLES	—	6	—
COMPRESSION THERAPY			
 LEVEL	LOW	LOW	HIGH
 TREATMENT TIME	5 MINUTES	15 MINUTES	60 MINUTES

FIG. 10B
 SUBSTITUTE SHEET (RULE 26)

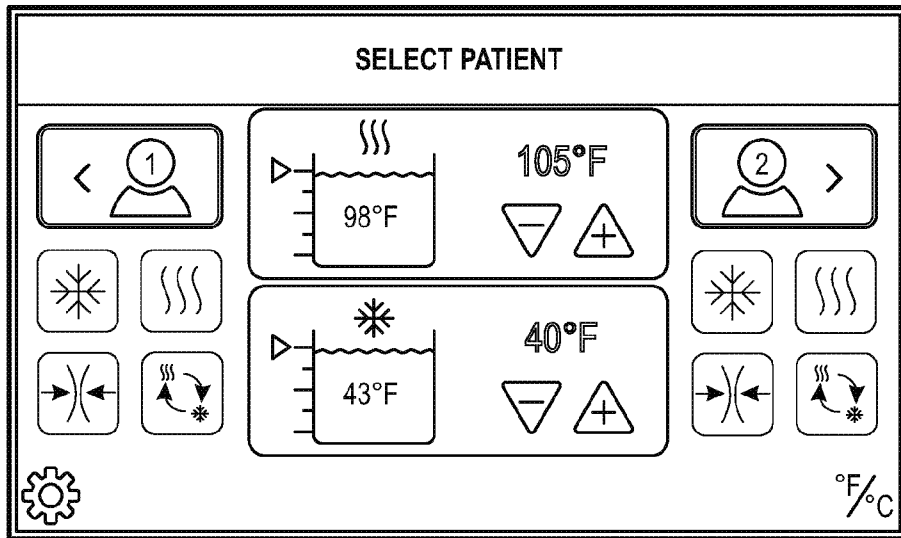

FIG. 11A

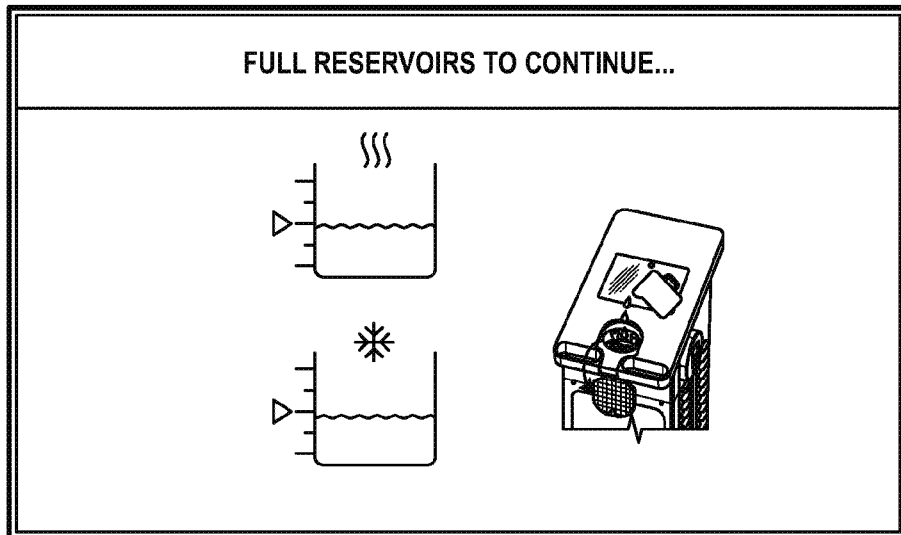

FIG. 11B

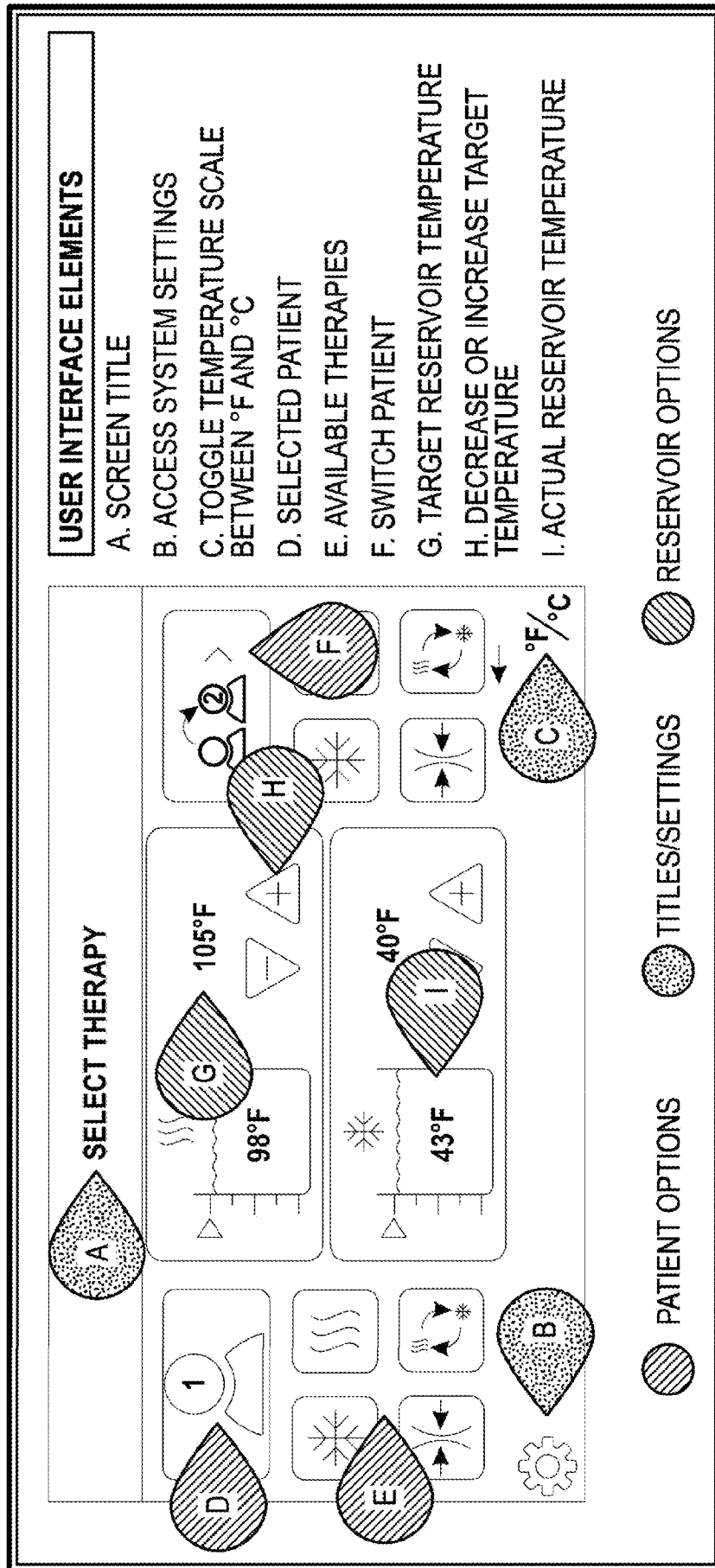

FIG. 11C

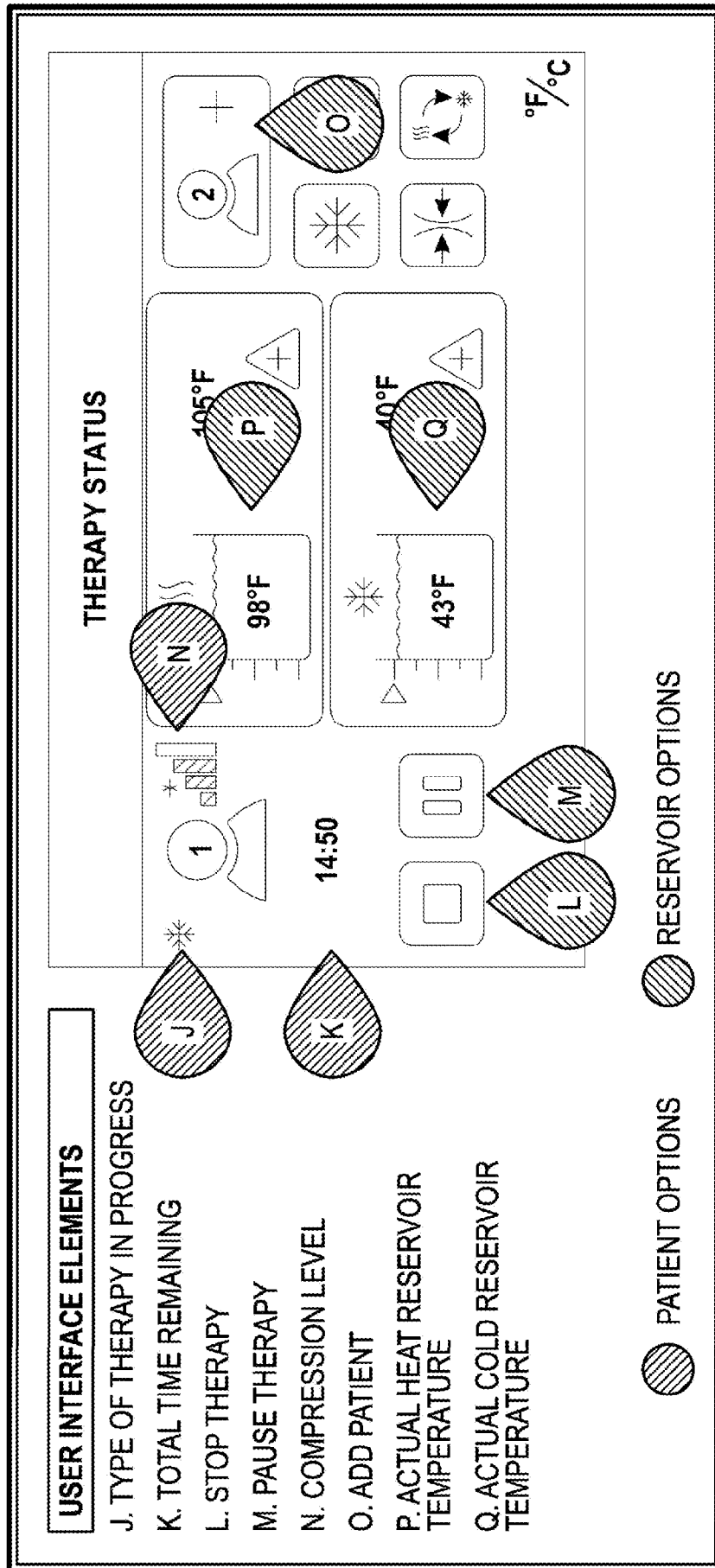

FIG. 11D









































THERAPY ICONS	
THE USER INTERFACE USES ICONS TO CONTROL THE UNIT.	
ICON	NAME
	ACCESS SYSTEM SETTINGS
	TOGGLE BETWEEN FAHRENHEIT(°F) AND CELSIUS(°C)
	HEAT RESERVOIR LEVEL AND CURRENT RESERVOIR TEMPERATURE
	COLD RESERVOIR LEVEL AND CURRENT RESERVOIR TEMPERATURE
	HEAT TEMPERATURE ALREADY SET
	COLD TEMPERATURE ALREADY SET
	INCREASE SETTING
	DECREASE SETTING
	START THERAPY
	CANCEL
	PAUSE THERAPY
	STOP THERAPY
	PATIENT 1 ADD
	PATIENT1 SELECT
	PATIENT 1 SWITCH
	PATIENT 2 ADD
	PATIENT 2 SELECT
	PATIENT 2 SWITCH
	COLD THERAPY
	ADJUST COLD THERAPY SETTINGS
ICON	NAME
	TOGGLE SNOOZE ON
	TOGGLE SNOOZE OFF
	SNOOZE TOTAL NUMBER OF CYCLES
	SNOOZE CYCLE STATUS
	HEAT THERAPY
	ADJUST HEAT THERAPY SETTINGS
	RAPID CONTRAST THERAPY
	ADJUST RAPID CONTRAST THERAPY SETTINGS
	SET BEGINNING THERAPY
	RAPID CONTRAST THERAPY HEAT TIME
	RAPID CONTRAST THERAPY COLD TIME
	RAPID CONTRAST THERAPY TOTAL TIME
	COMPRESSION-ONLY
	ADJUST COMPRESSION-ONLY THERAPY SETTINGS
	NO COMPRESSION (NONE)
	LOW-COMPRESSION (5-15 mm Hg)
	MEDIUM-LOW COMPRESSION (5-30 mm Hg)
	MEDIUM COMPRESSION (5-50 mm Hg)
	HIGH COMPRESSION (5-75 mm Hg)
	ALARM
	ATTENTION: CONSULT USER MANUAL

FIG. 11E

SYSTEM SETTINGS ICONS

THE SYSTEM SETTING USER INTERFACE USES ICONS TO CONTROL THE UNIT'S DEFAULT SETTINGS.

ICON	NAME
	ACCESS SYSTEM SETTINGS
	CHANGE PERSONAL IDENTIFICATION NUMBER (PIN)
	FACTORY RESET
	LANGUAGE
	SYSTEM INFORMATION
	DATA DOWNLOAD
	SOFTWARE UPDATE
	COLD THERAPY SETTINGS
	COLD THERAPY TIME SETTINGS
	COLD THERAPY COMPRESSION SETTINGS
	COLD RESERVOIR TEMPERATURE SETTINGS
	SNOOZE SETTINGS
	ENABLE SNOOZE
	DISABLE SNOOZE
	HEAT THERAPY SETTINGS
	HEAT THERAPY TIME SETTINGS
	HEAT THERAPY COMPRESSION SETTINGS

ICON	NAME
	HEAT RESERVOIR TEMPERATURE SETTINGS
	RAPID CONTRAST THERAPY
	RAPID CONTRAST TIME SETTINGS
	COMPRESSION - ONLY THERAPY SETTINGS
	COMPRESSION - ONLY THERAPY TIME SETTINGS
	CANCEL
	CONFIRM
	RETURN
	EXIT TO SAVE SETTINGS (RESTART REQUIRED)
	NO COMPRESSION (5-15 mm Hg)
	MEDIUM-LOW COMPRESSION (5-30 mm Hg)
	MEDIUM COMPRESSION (5-50 mm Hg)
	HIGH COMPRESSION (5-50 mm Hg)

SYSTEM STATES

- IF A THERAPY TREATMENT IS IN SESSION, THE SYSTEM AND GUI REMAIN ON 100%
- IF THE MED4 ELITE HAS NOT BEEN IN USE FOR X TIME, THE GUI DIMS
- SCREEN SAVER MODE
- AFTER ONE HOUR OF NO USE, X
- AFTER 6 HOURS OF NO USE, THE SYSTEM AUTOMATICALLY POWERS OFF

FIG. 11F
SUBSTITUTE SHEET (RULE 26)

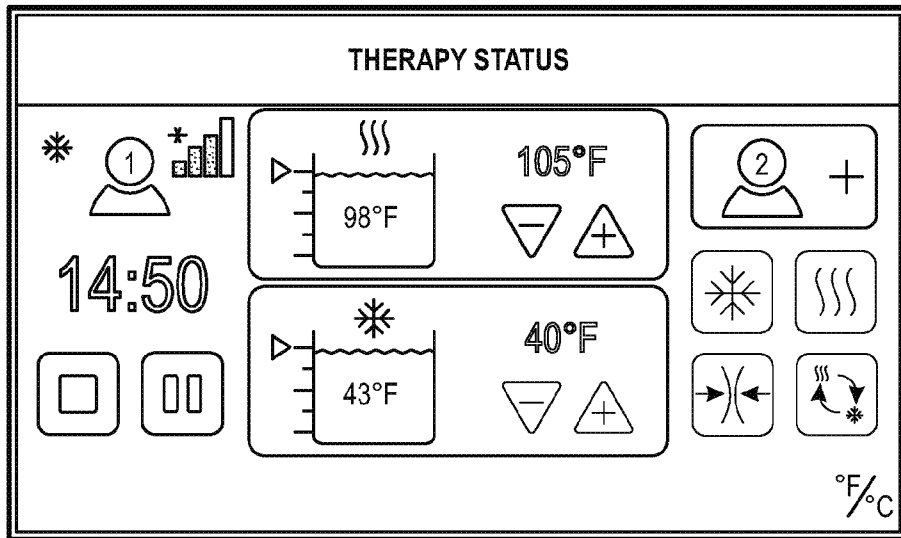
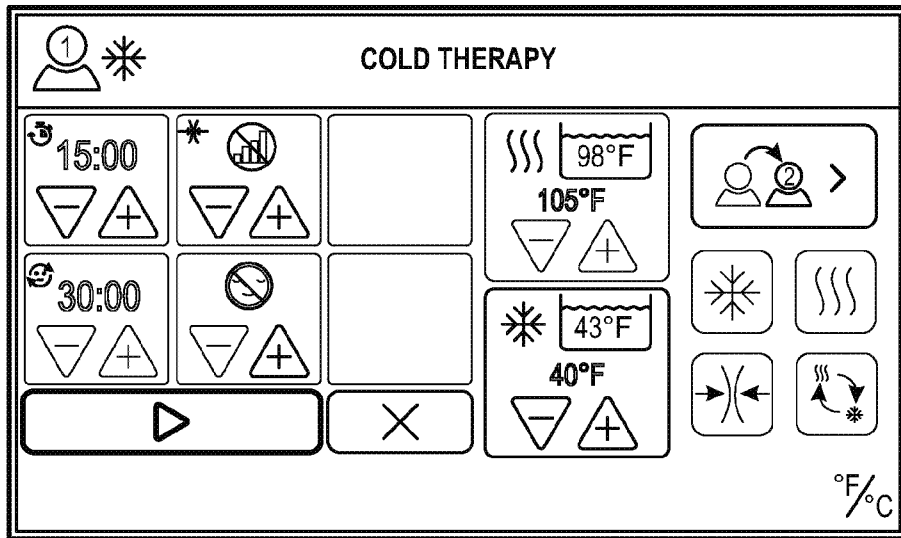

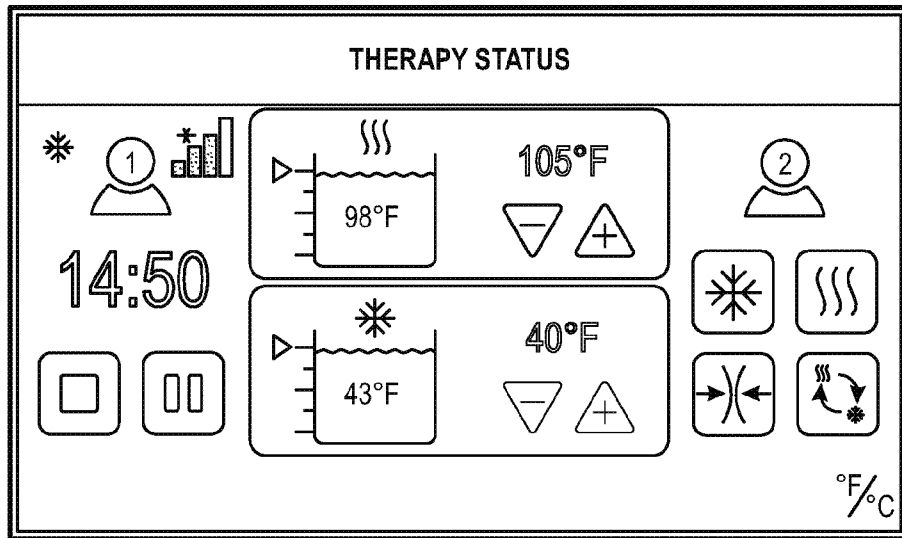

FIG. 11I

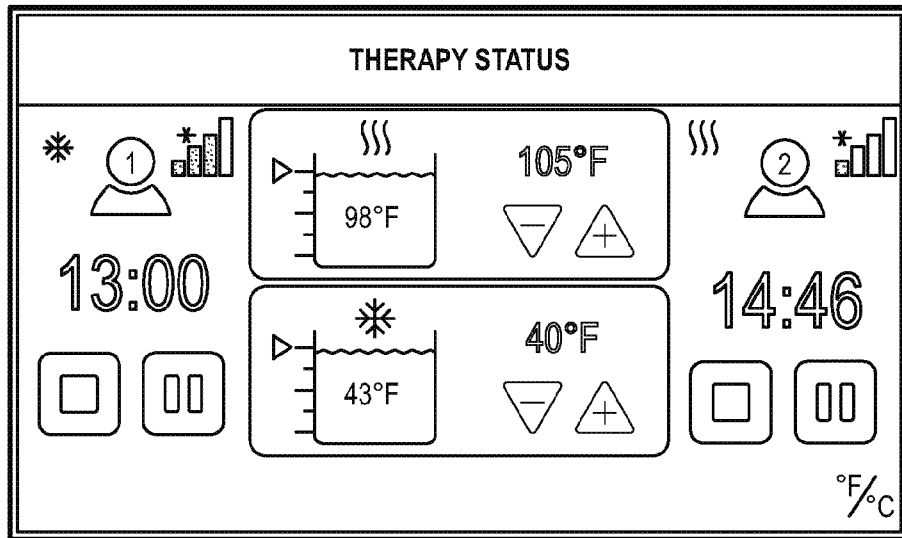

FIG. 11J

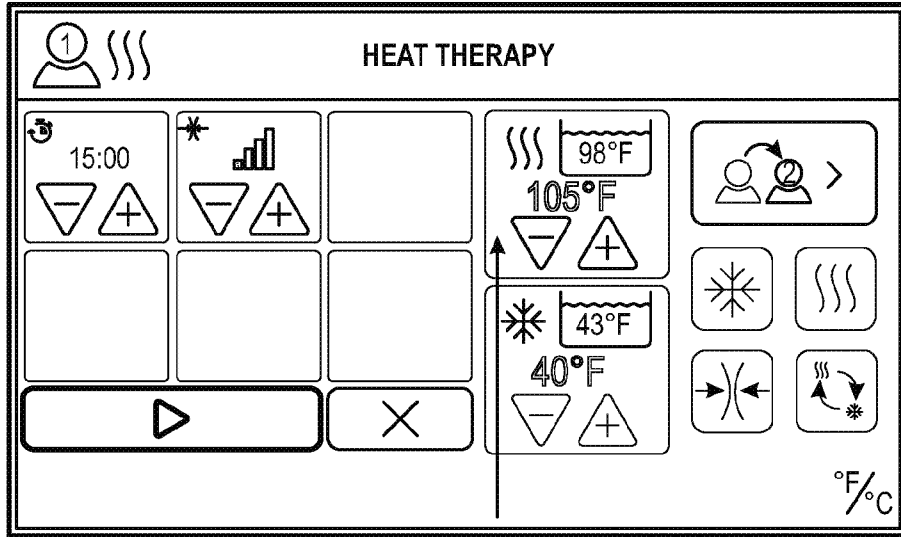

FIG. 11K

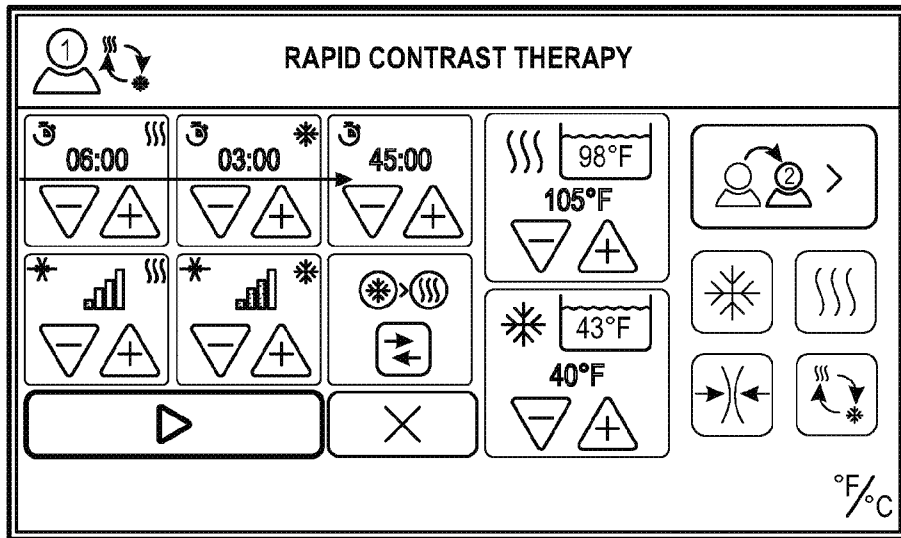

FIG. 11L

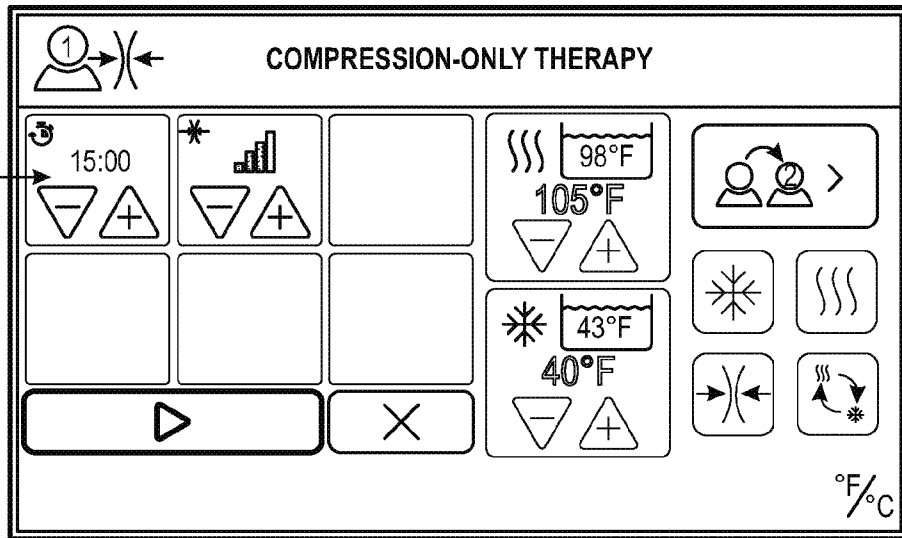

FIG. 11M

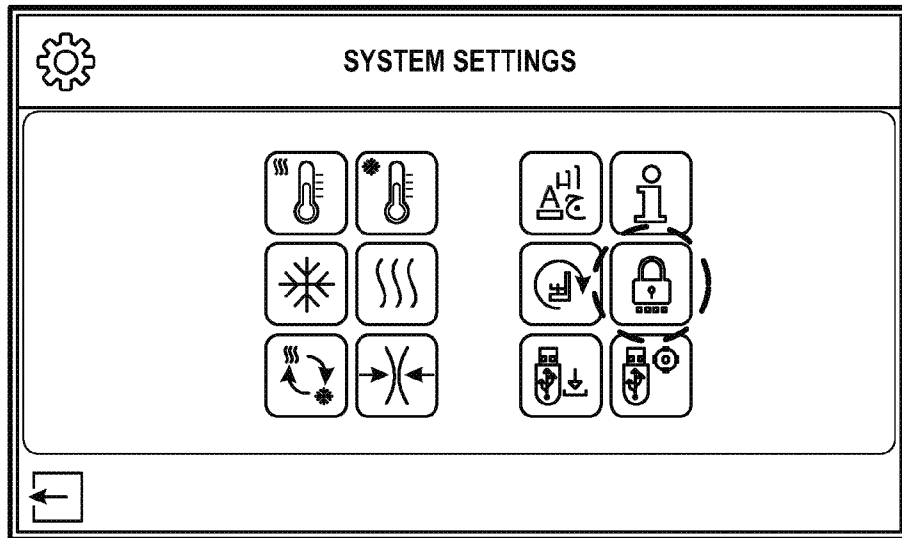

FIG. 11N

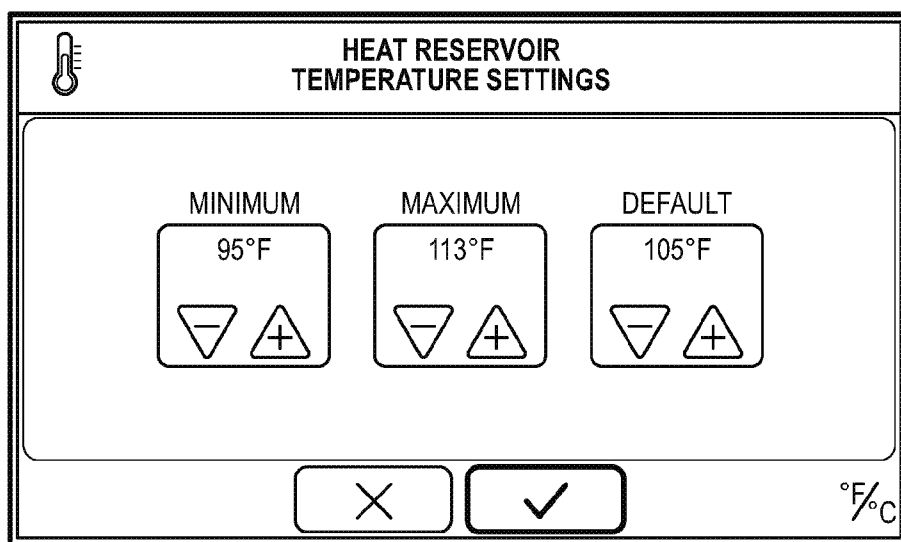

FIG. 110

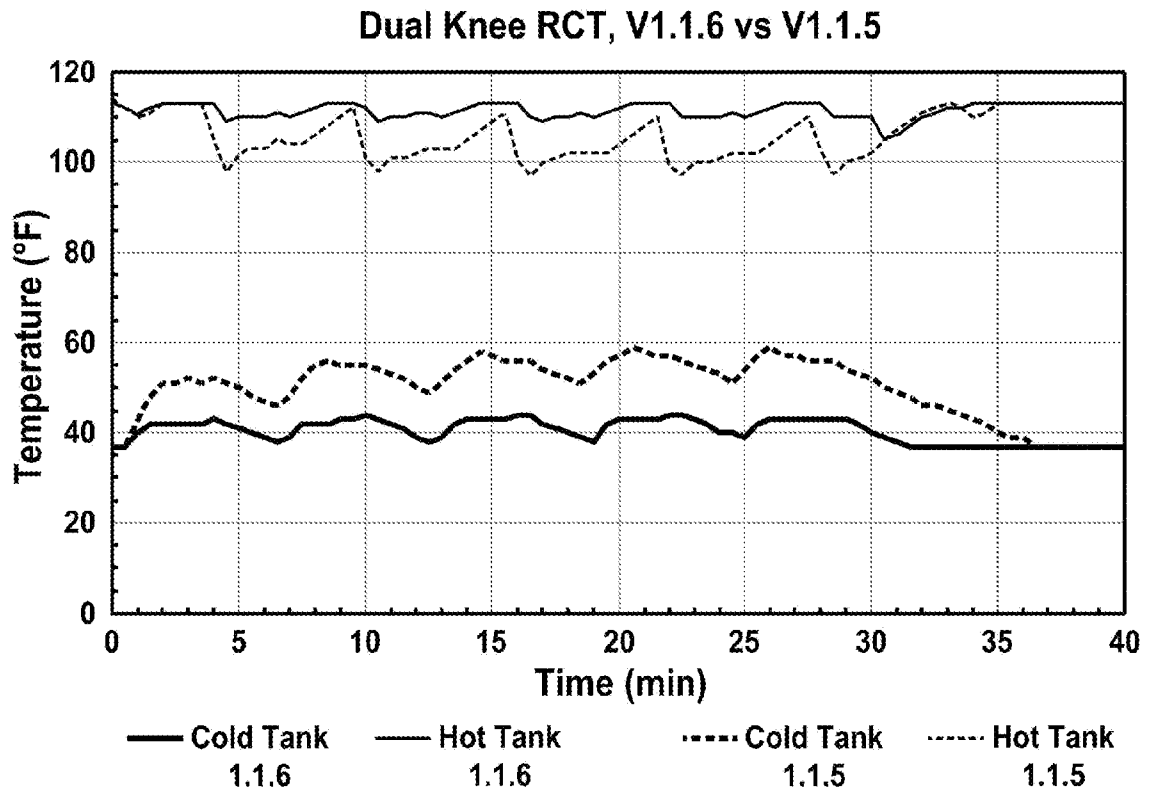

FIG. 12

INTERNATIONAL SEARCH REPORT

International application No.
PCT/US2019/039625

A. CLASSIFICATION OF SUBJECT MATTER
IPC(8) - A61F 7/00; A61F 7/02; A61F 7/03; A61F 7/08; A61F 7/10 (2019.01)
CPC - A61F 7/0085; A61F 7/00; A61F 7/0053; A61F 7/02; A61F 2007/0295; A61F 2007/0296; A61F 7/08; A61F 7/10 (2019.08)

According to International Patent Classification (IPC) or to both national classification and IPC

B. FIELDS SEARCHED

Minimum documentation searched (classification system followed by classification symbols)
See Search History document

Documentation searched other than minimum documentation to the extent that such documents are included in the fields searched
USPC - 604/291; 607/96; 607/104; 607/108; 607/114 (keyword delimited)

Electronic data base consulted during the international search (name of data base and, where practicable, search terms used)
See Search History document

C. DOCUMENTS CONSIDERED TO BE RELEVANT

Category*	Citation of document, with indication, where appropriate, of the relevant passages	Relevant to claim No.
X	NL 2011288 C2 (A.C.S. B.V.) 10 February 2015 (10.02.2015) see machine translation	1-3
A	US 6,508,831 B1 (KUSHNIR) 21 January 2003 (21.01.2003) entire document	1-3
A	US 2014/0222121 A1 (SPENCE et al) 07 August 2014 (07.08.2014) entire document	1-3
A	US 2015/0335468 A1 (PHYSIOLAB TECHNOLOGIES LIMITED) 26 November 2015 (26.11.2015) entire document	1-3

Further documents are listed in the continuation of Box C. See patent family annex.

* Special categories of cited documents:
 "A" document defining the general state of the art which is not considered to be of particular relevance
 "E" earlier application or patent but published on or after the international filing date
 "L" document which may throw doubts on priority claim(s) or which is cited to establish the publication date of another citation or other special reason (as specified)
 "O" document referring to an oral disclosure, use, exhibition or other means
 "P" document published prior to the international filing date but later than the priority date claimed
 "T" later document published after the international filing date or priority date and not in conflict with the application but cited to understand the principle or theory underlying the invention
 "X" document of particular relevance; the claimed invention cannot be considered novel or cannot be considered to involve an inventive step when the document is taken alone
 "Y" document of particular relevance; the claimed invention cannot be considered to involve an inventive step when the document is combined with one or more other such documents, such combination being obvious to a person skilled in the art
 "&" document member of the same patent family

Date of the actual completion of the international search
21 August 2019

Date of mailing of the international search report
17 SEP 2019

Name and mailing address of the ISA/US
Mail Stop PCT, Attn: ISA/US, Commissioner for Patents
P.O. Box 1450, Alexandria, VA 22313-1450
Facsimile No. 571-273-8300

Authorized officer
Blaine R. Copenheaver
PCT Helpdesk: 571-272-4300
PCT OSP: 571-272-7774

INTERNATIONAL SEARCH REPORT

International application No.

PCT/US2019/039625

Box No. II Observations where certain claims were found unsearchable (Continuation of item 2 of first sheet)

This international search report has not been established in respect of certain claims under Article 17(2)(a) for the following reasons:

1. Claims Nos.:
because they relate to subject matter not required to be searched by this Authority, namely:

2. Claims Nos.:
because they relate to parts of the international application that do not comply with the prescribed requirements to such an extent that no meaningful international search can be carried out, specifically:

3. Claims Nos.: 4-93
because they are dependent claims and are not drafted in accordance with the second and third sentences of Rule 6.4(a).

Box No. III Observations where unity of invention is lacking (Continuation of item 3 of first sheet)

This International Searching Authority found multiple inventions in this international application, as follows:

1. As all required additional search fees were timely paid by the applicant, this international search report covers all searchable claims.
2. As all searchable claims could be searched without effort justifying additional fees, this Authority did not invite payment of additional fees.
3. As only some of the required additional search fees were timely paid by the applicant, this international search report covers only those claims for which fees were paid, specifically claims Nos.:

4. No required additional search fees were timely paid by the applicant. Consequently, this international search report is restricted to the invention first mentioned in the claims; it is covered by claims Nos.:

Remark on Protest

- The additional search fees were accompanied by the applicant's protest and, where applicable, the payment of a protest fee.
- The additional search fees were accompanied by the applicant's protest but the applicable protest fee was not paid within the time limit specified in the invitation.
- No protest accompanied the payment of additional search fees.