

E. E. COMAN.
 COUPLING.
 APPLICATION FILED DEC. 1, 1909

999,963.

Patented Aug. 8, 1911.

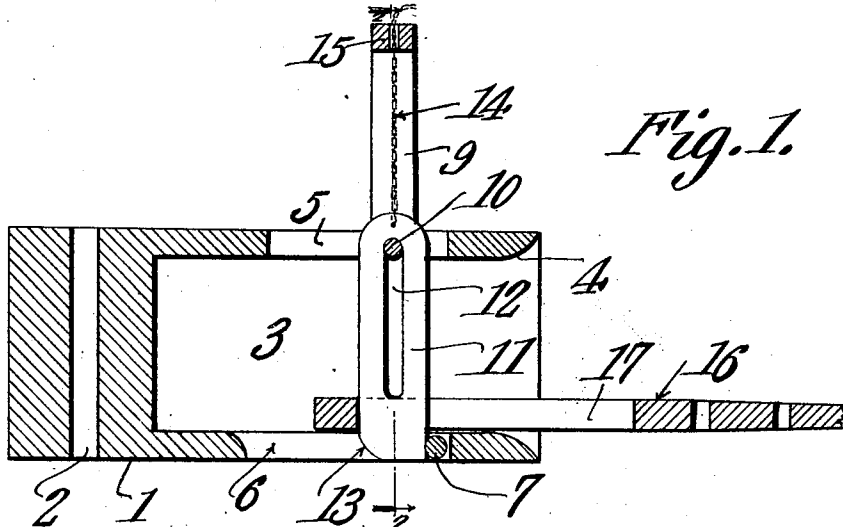

Fig. 1.

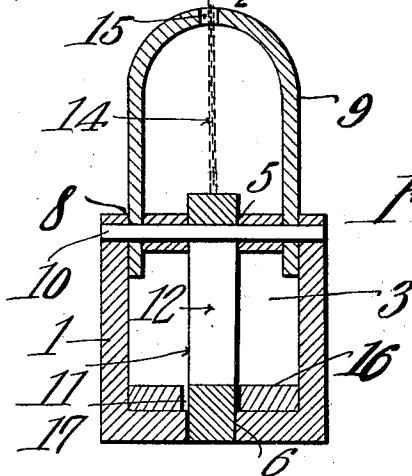
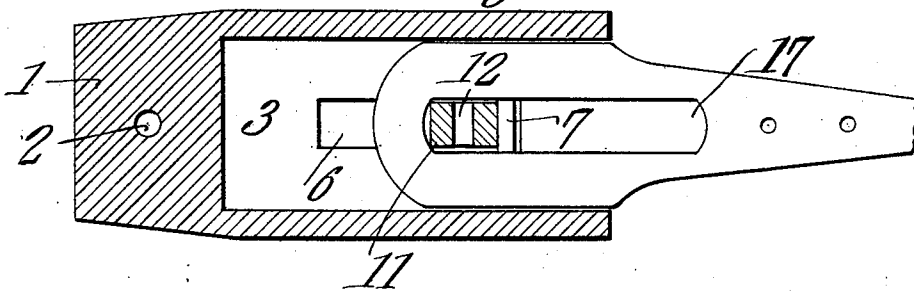

Fig. 2.

Fig. 3.



Witnesses
E. E. Coman
J. T. Lawson

Inventor
Edgar E. Coman.
 By *C. A. Snow & Co.*
 Attorneys

UNITED STATES PATENT OFFICE.

EDGAR E. COMAN, OF WALDRON, MICHIGAN.

COUPLING.

999,963.

Specification of Letters Patent.

Patented Aug. 8, 1911.

Application filed December 1, 1909. Serial No. 530,786.

To all whom it may concern:

Be it known that I, EDGAR E. COMAN, a citizen of the United States, residing at Waldron, in the county of Hillsdale and State of Michigan, have invented a new and useful Coupling, of which the following is a specification.

This invention has relation to couplings especially adapted to be used for connecting a thresher or like machine with a traction engine and it consists in the novel construction and arrangement of its parts as hereinafter shown and described.

The object of the invention is to provide a simple, effective and durable coupling to be used as indicated which consists of a head block with means for pivotally mounting the same upon the frame of the engine and a draw-bar adapted to fit in said block and restrained against lateral swing with relation to the block but free to move to a limited extent vertically within the block. By such arrangement when the engine and trailing machine are making a turn the lateral pivotal movement occurs at the pivotal connection between the block and the engine frame and not between the members of the coupling. If however, the engine and trailing machine should pass over uneven places in the road the said engine and trailing machine may have relative vertical movement by reason of the fact that the draw-bar is permitted to have limited vertical movement in the head block of the coupling.

In the accompanying drawings:—Figure 1 is a vertical longitudinal sectional view of the coupling. Fig. 2 is a transverse sectional view of the same on the line 2—2 of Fig. 1. Fig. 3 is a horizontal longitudinal section of the same.

The coupling consists of a head block 1 having a vertically disposed pin perforation 2 adapted to receive a pin mounted upon the frame of an engine and thus forming means whereby the said head block is pivotally connected with the engine frame. At the end of the block 1 opposite the end thereof containing the perforation 2 is formed a longitudinally disposed throat 3 having a bell shaped mouth 4. The head block 1 is provided with a top slot 5 and a bottom slot 6 both of which communicate at their inner ends with the throat 3. A bolt 7 passes transversely through the lower forward portion of the head block 1 and also through the forward end of the slot 6 and

forms an abutment for a locking pin as will be hereinafter explained. The head block 1 is provided in its top with slots 8 which receive the end of an arched member 9, the intermediate portion of which bridges the slot 5 at a point intermediate the ends thereof. A bolt 10 passes transversely through the top of the head block 1, also through the slot 5 and through the end of the arched member 9 and serves as means for securing the said arch member in the slot 8.

A pin 11 is provided with an elongated slot 12 which receives the bolt 10. The pin is of sufficient length so that when in a vertical position it projects through the slots 5 and 6 and bears at its lower forward edge against the bolt 7 in the slot 6. The lower rear end of the pin 11 is rounded or chamfered as at 13. A chain or other flexible member 14 is connected at one end with the upper end of the pin 11 and passes through a perforation 15 provided in the top of the arch member 9.

A draw-bar 16 is provided with an elongated slot 17 and the extremity of that end which is adapted to enter the draw-head 1 is rounded as at 18. The slot 17 is of sufficient breadth to snugly receive the pin 11 and the said draw-bar 16 is of such breadth in a horizontal direction as to fit snugly against or within the side walls of the throat 3 of the head block 1. The vertical thickness of the draw-bar 16 is such that the said draw-bar when inserted in the throat 3 of the head-block 1 may move vertically to a limited extent. The draw-bar 16 is adapted to be attached to the tongue or other part of the trailing machine.

The operation of the coupling is as follows: The locking pin 11 normally hangs in a vertical position in the slots 5 and 6 and as the traction engine to which the head block 1 is attached is backed toward the thresher or other machine carrying the draw-bar 16 the said draw-bar is directed into the mouth 4 of the throat 3 of the head-block 1. When the rounded end 18 of the draw-bar 16 comes in contact with the lower portion of the locking pin 11 the said pin is swung away from the draw-bar 16 upon the bolt 10 as a pivot. When the end of the slot 17 passes beyond the lower end of the pin 11 the said pin falls by gravity through the slot 17 and assumes a vertical position in the slots 5 and 6 with its lower forward edge against the bolt 7. Thus the parts are

coupled together and when the engine to which the draw-head is attached is moved in a forward direction the draw-bar 16 will drag the trailing machine behind. To un-

5 couple the members the chain 14 is pulled whereby the locking pin 11 is lifted out of the slot 17 and as the engine continues a forward movement the draw-bar 16 slips out of the throat of the head-block 1. By

10 this arrangement it will be seen that a simple and effective coupling is provided; that the parts act automatically during the coupling operation and that the members may be easily and quickly uncoupled. At the

15 same time it will be seen that the draw-bar 16 is restrained against lateral swing with relation to the head block 1 but that means is provided for pivotally mounting the head block. Consequently when the machines to

20 which the coupling members are attached are turning the pivotal movement at the coupling occurs at the pivotal point of the head block and not between the head block and the draw-bar. It will also be seen that

25 the said draw-bar may have limited vertical movement with relation to the head block and this will permit the machine to pass over uneven places in a road-way without straining the component parts of the coupling.

30 Inasmuch as the present coupling is especially adapted to be used as means for connecting a thresher or other trailing machine to a traction engine the coupling is designed with a view of being especially

35 adapted for this purpose. In the first place it is desirable in a coupling when so used that the parts should be light and occupy minimum space, at the same time the structure must be strong and able to withstand

40 the strains and sudden jars to which it is subjected when in use. Such a coupling is subjected to conditions at times which couplings used upon railway cars or tram cars are not subjected to. The traction engine

45 and its trailer passes over a rough road the trailer sometimes moves in a forward direction at a greater rate of speed than the engine and at other times the engine moves in a forward direction at a greater rate of

50 speed than the trailer. This is due to the inequalities usually found in the road bed, consequently when the draw-bar 16 is suddenly drawn in a forward direction against the rear edge of the locking pin 11, there is

55 unusual sudden impact between the forward edge of the said pin and the bolt 7 in the lower slot of the head block. The head block is a casting as has hereinbefore been explained for the reason that it is desirable

60 to have this structure light while the bolt 7 is of wrought metal as is also the coupling pin and the draw-bar. Therefore these

parts are better able to stand the impact of sudden jars and they are the parts which in a great measure sustain these jars and relieve the cast parts of the coupling from unnecessary or sudden shock. It is of course understood that where coupling devices are designed to be used upon railroad cars and tram cars or other vehicles which travel upon a comparatively level or regularly inclined track the sudden jarring of the parts in the instance above mentioned is eliminated and the major portions of the coupling may be cast. Again on vehicles that travel upon a track the question of weight is not a material element to be considered and the parts are usually of such transverse thickness as to withstand the strains and jars to which they may be subjected. It will therefore be seen that in view of the fact that applicant's coupling is for special applications that the special construction of the same constitutes the essential features of his invention.

Having described the invention what I claim as new and desire to secure by Letters Patent is:—

A coupling comprising a head block having a longitudinally disposed throat provided with plain vertical side walls, said block having in its top and bottom elongated slots which communicate with the throat, a bolt located in the head block and lying transversely across the slot in the top thereof, a second bolt located in the head block and lying transversely across the outer end portion of the slot in the bottom thereof, a locking pin having an elongated slot which receives the bolt in the upper slot of the head block, said pin when hanging pendant from said bolt having its lower end portion located in the lower slot of the head block, and its forward edge in engagement with the bolt in the lower slot, means for raising said pin, and a draw-bar adapted to fit snugly between the vertical side walls of the throat in the head block and having an elongated slot adapted to receive the intermediate portion of the locking pin, the lower portion of said pin engaging the said lower bolt, whereby the head block and draw-bar are held in longitudinal alinement but the draw-bar is free to move throughout the entire vertical depth of the throat in the head block.

In testimony that I claim the foregoing as my own, I have hereto affixed my signature in the presence of two witnesses.

EDGAR E. COMAN.

Witnesses:

W. B. SHUMWAY,
JAMES D. ANDERSON.