

J. H. EBERSOLE.
ENGINE.

APPLICATION FILED OCT. 6, 1909.

Patented July 18, 1911.

3 SHEETS-SHEET 1.

998,284.

FIG. 1.

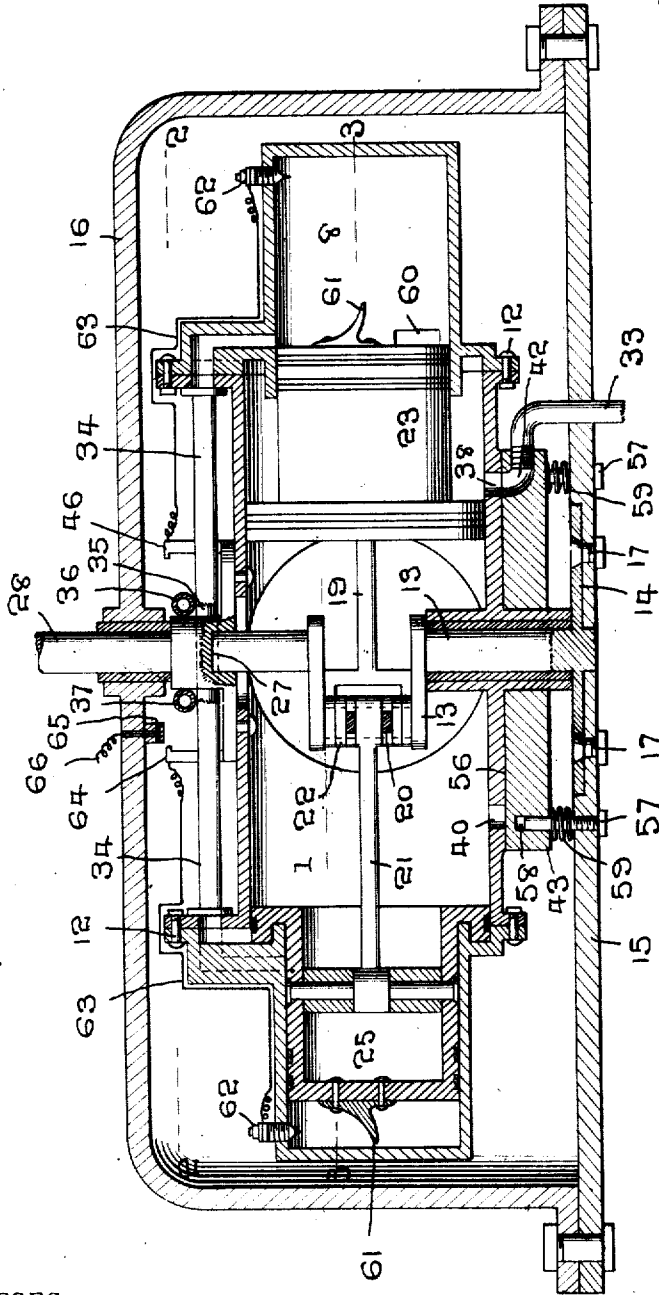

WITNESSES:

Thos. W. Riley
M. Newcomb.

J. H. Ebersole
INVENTOR

BY *W. J. Fitzgerald & Co.*
Attorneys

J. H. EBERSOLE.
 ENGINE.
 APPLICATION FILED OCT. 6, 1909.

998,284.

Patented July 18, 1911.

3 SHEETS—SHEET 2.

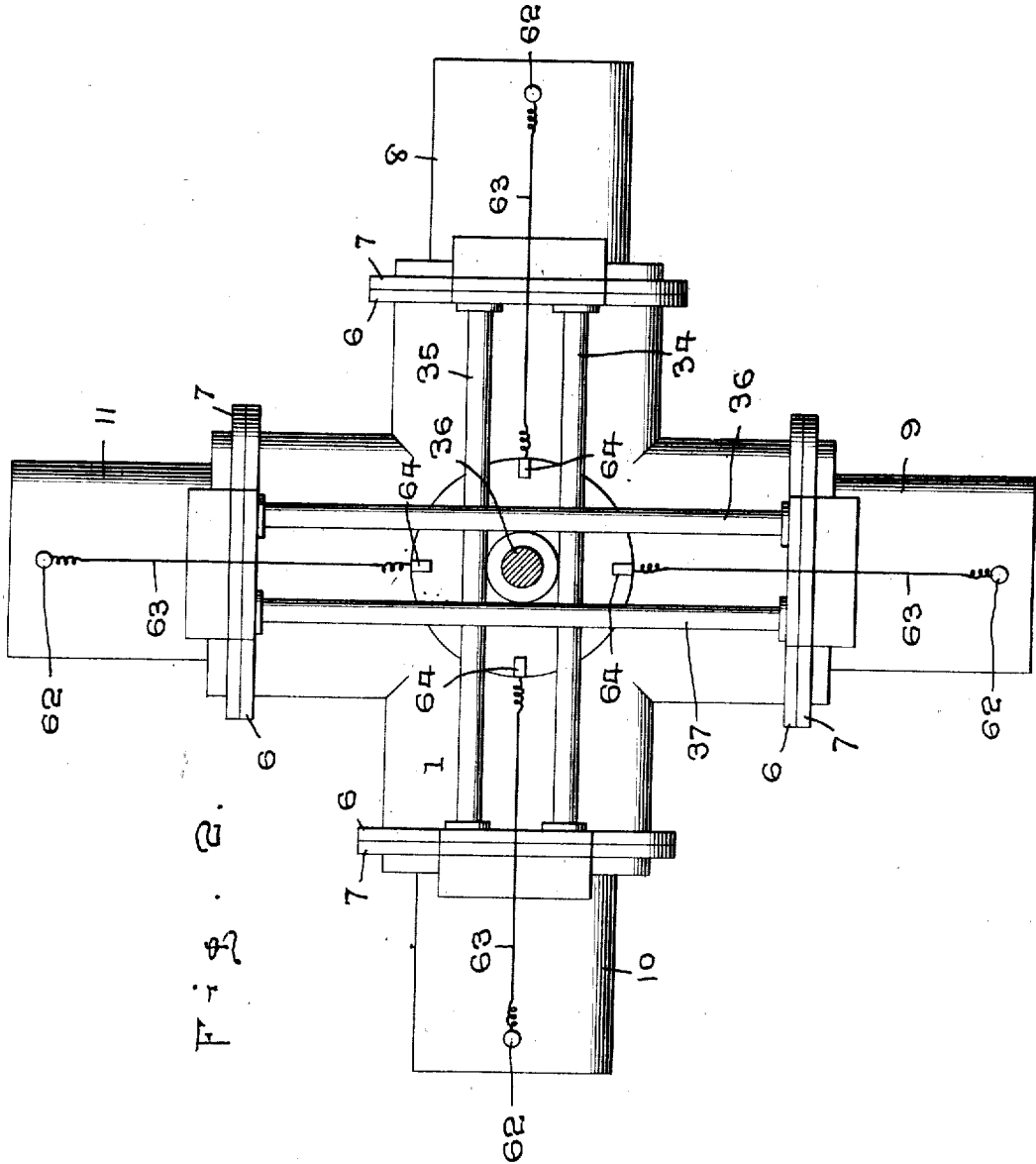

Fig. 2.

WITNESSES:

Thos. W. Riley
M. Neivcomb

J. H. E. INVENTOR
 bersole

BY
W. J. Fitzgerald & Co
 Attorney

J. H. EBERSOLE.
ENGINE.

APPLICATION FILED OCT. 8, 1909.

Patented July 18, 1911.

3 SHEETS-SHEET 3.

998,284.

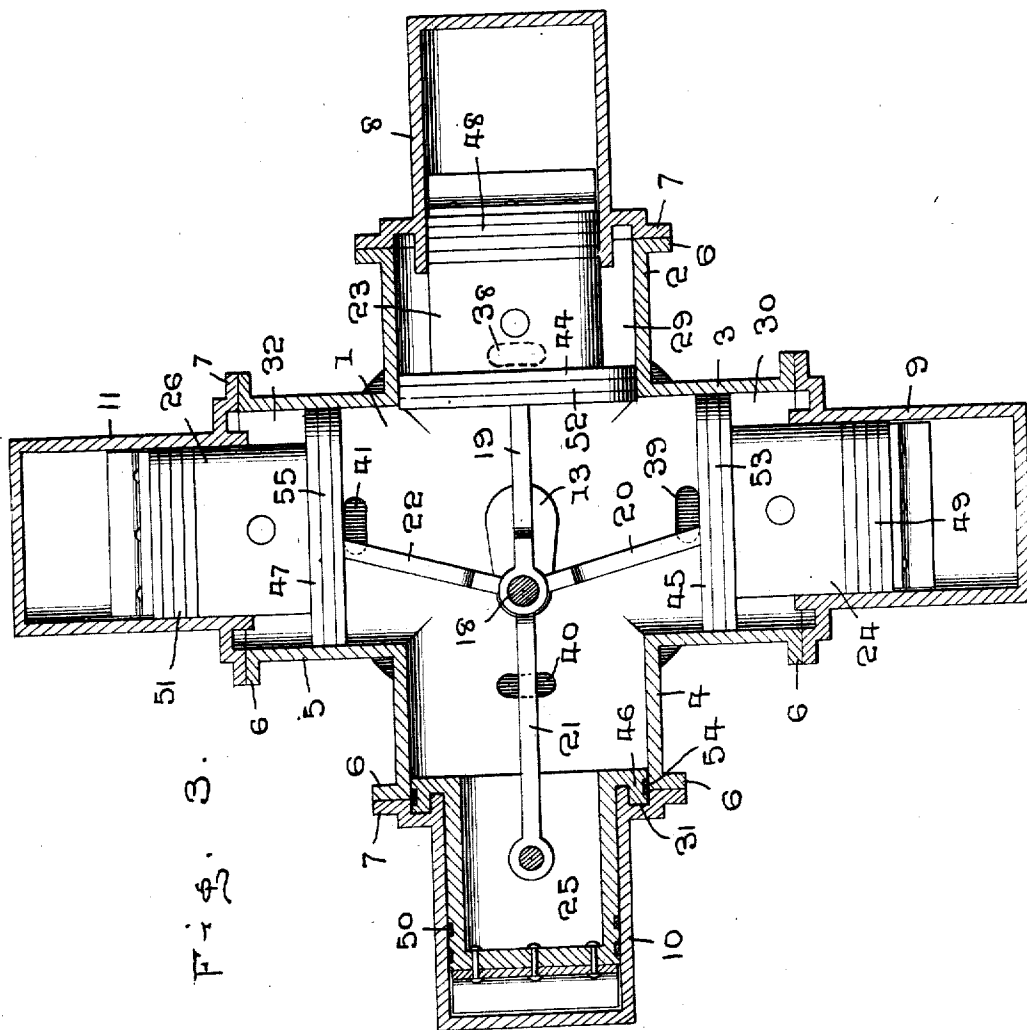

Fig. 3.

WITNESSES:

Thos. W. Riley
M. Newcomb

J. H. Ebersole
INVENTOR

BY
W. J. Fitzgerald & Co
Attorneys

UNITED STATES PATENT OFFICE.

JOHN H. EBERSOLE, OF WASHINGTON, DISTRICT OF COLUMBIA.

ENGINE.

998,284.

Specification of Letters Patent.

Patented July 18, 1911.

Application filed October 6, 1909. Serial No. 521,361.

To all whom it may concern:

Be it known that I, JOHN H. EBERSOLE, a citizen of the United States, residing at Washington, District of Columbia, have invented certain new and useful Improvements in Engines; and I do hereby declare the following to be a full, clear, and exact description of the invention, such as will enable others skilled in the art to which it appertains to make and use the same.

My invention relates to new and useful improvements in engines, and more particularly to that class known as two cycle engines and adapted to be used for propelling vehicles and my object is to provide an engine of this class whereby the cylinders will rotate around a stationary shaft.

A further object is to so construct the piston driving pitmen that all of said pitmen may be operated from a single crank.

A further object is to provide auxiliary chambers in the casing of the engine, whereby the gas employed for operating the engine may be compressed and forced from one chamber into the cylinder at the opposite side of the engine.

A further object is to provide suitable means for conveying the gas into the cylinders.

A still further object is to provide suitable ports whereby said cylinders may be connected in pairs and a further object is to provide means for igniting the contents of the cylinders to cause explosion.

Other objects and advantages will be hereinafter referred to and more particularly pointed out in the claims.

In the accompanying drawings forming part of this application, Figure 1 is a transverse sectional view through the engine. Fig. 2 is a sectional view as seen on line 2-2, Fig. 1, showing the housing for the engine removed, and, Fig. 3 is a horizontal sectional view as seen on line 3-3, Fig. 1.

Referring to the drawings in which similar reference numerals designate corresponding parts throughout the several views, 1 indicates the casing of the engine, which casing is provided with tubular extensions 2, 3, 4 and 5, the outer ends of said extensions having peripheral flanges 6 to receive the peripheral flanges 7 of the cylinders 8, 9, 10 and 11, which cooperate with the extensions 2, 3, 4 and 5, respectively, said cylinders being removably attached to the exten-

sions by introducing bolts or the like 12 through said flanges.

Extending vertically through the casing 1 is a shaft 13, the lower end of the shaft having a cross head 14 which is embedded in the base 15 of a housing 16, said cross head being secured to the base by means of bolts or the like 17, thus holding the shaft in fixed relationship with said housing. That portion of the shaft 13 extending through the casing 1 is provided with a crank portion 18 to which are attached the inner ends of pitmen 19, 20, 21 and 22, which are adapted to operate pistons 23, 24, 25, and 26, said pistons cooperating with the cylinders 8, 9, 10 and 11, respectively and it will be readily seen that as the shaft 13 is held stationary, the rotation of the casing and cylinders around said shaft will move the pistons into and out of the cylinders. The upper end of the shaft 13 is entered into a seat 27 in the base portion of a driving shaft 28, said driving shaft being fixed to the casing 1 and extended upwardly through the upper wall of the housing 16 and to said upwardly extending portion of the driving shaft is to be attached any suitable form of means for connecting the engine to the parts of the vehicle, whereby said vehicle may be driven.

It will be understood of course that the shaft 13 and driving shaft 28 may be turned end to end, whereby the drive will be below the engine instead of above the same, the operation of the parts being otherwise identical.

The extensions upon the casing 1 are greater in diameter than the diameter of the cylinders attached thereto, so that when the pistons are moved inwardly, auxiliary chambers 29, 30, 31 and 32 are formed between the inner faces of said extensions and the outer faces of said pistons and into said auxiliary chambers is introduced the gas from the carbureter pipe 33. After the gas has entered the auxiliary chamber, the return stroke of the piston will compress the gas therein and when the piston has completed its inward stroke, it will force said gas so compressed through the ports into the other cylinder.

The cylinder 8 is connected to the auxiliary compartment 31 through a pipe or port 34, while the auxiliary chamber 29 is connected to the cylinder 10 through the

medium of a pipe 35, while the cylinder 11 is connected to the auxiliary chamber 30 through the medium of a pipe 36 and the cylinder 9 to the auxiliary chamber 32 through a pipe 37 and the auxiliary chambers are provided with ports 38, 39, 40 and 41, respectively, which are successively moved into registration with a port 42 in a disk 43, the end of the pipe 33 communicating with the port in said disk.

The inner ends of the pistons are provided with auxiliary heads 44, 45, 46 and 47, respectively, which auxiliary heads are adapted to fit the interior of the extensions 2, 3, 4 and 5, respectively, and act as pistons therein, the pistons 23, 24, 25, and 26 having packing rings 48, 49, 50 and 51, respectively, while the auxiliary heads are also provided with packing rings 52, 53, 54 and 55, respectively, which rings are constructed in the usual or any preferred manner and prevent leakage of the gases around the pistons and heads.

The disk 43 is held in frictional engagement with a ground face 56 on the casing and is held against rotation by introducing stud bolts 57 through the base 15 and into sockets 58 in said disk, the disk being firmly seated against the ground face by introducing springs 59 around the stud bolts between said base and disk.

In operation, supposing the parts to be set as shown in the several views, the live gas will be entering through the port 38 into the auxiliary chamber 29, while the gases previously taken into the auxiliary chamber 31 will have been compressed and forced through the pipe 34 into the cylinder 8 and as said gas is forced into the cylinder 8, the piston 23 will have completed its inward stroke and uncovered the exhaust port 60, the live gas being directed to the upper end of the cylinder 8, by the deflector 61, thus forcing the exhausted gas through said exhaust port 60. At the same time that the gas is being discharged into the cylinder 8, the piston 25 will have moved to its outward stroke and the charge in the cylinder 10 exploded in the usual or any preferred manner, the sparking plug 62 being connected to the usual or any preferred form of commutator or sparker through wires 63, each of the cylinders being provided with a plug and wire so that when they are successively brought into engagement with the distributor of the commutator, a spark will be directed into said cylinder and the charge ignited. The piston 24 at the time the pistons 23 and 25 are in the position shown, will be moving outwardly, thereby compressing the charge of gas in the cylinder 9 and the charge of gas in the auxiliary chamber 30, while the piston 26 will be moving inwardly and cause a vacuum in the auxiliary chamber 32, whereby when the

cylinder 9 has moved to the position now occupied by the cylinder 10, and the cylinder 11 to the position occupied by the cylinder 8, the piston 24 will have reached its full outward stroke and the piston 26 its full inward stroke, whereupon the gases compressed in the auxiliary chamber 30 will be discharged through the pipe 36 and into the cylinder 11, the exhaust port in said cylinder being likewise uncovered and permitting the exhaust gas to escape. As the cylinders rotate, the posts 64 to which the wires 63 are attached, are successively brought into cooperation with the brush 65 carried by the housing 16, said brush being connected to the commutator (not shown) through the medium of a wire 66 and as said brush is located in such position as to operate the plugs to cause a spark when the cylinders reach the point now occupied by the cylinder 10, the charges in all of said cylinders will be exploded when they have reached this particular point.

By mounting the cylinders in a horizontal position and causing the same to rotate around the shaft 13, said cylinders will be self-cooling, as well as form a balance wheel, thereby dispensing with the heavy balance wheel now employed and it will further be seen that by compressing the air in the auxiliary compartments, instead of taking the same direct from the carbureter or from the crank case, the gases will be more readily entered in the cylinders, thereby obtaining a more perfect feed of the gases. It will further be seen that by taking the gases through the auxiliary compartments instead of through the crank case, the objectionable feature of providing stuffing boxes will be obviated and the gases will be prevented from escaping, as is the case in the present form of engine. It will likewise be seen that by entering the gas into the cylinders as shown, the back fire resulting from low pressure or improper mixture of the gases will result in no damage as the port to the mixing chamber is closed at the time of entering the charge into the cylinder.

What I claim is:

1. A gas engine comprising a casing having a plurality of tubular extensions arranged in pairs of diametrically opposite members, a flange on the outer extremity of each of said tubular extensions, flanged cylinders of less diameter carried by the tubular extensions, the flanges of said cylinders abutting the flanges of said tubular extensions, a piston sliding within each of the cylinders, said pistons having enlarged inner portions sliding within the tubular extensions and forming auxiliary chambers around the pistons when the pistons are moved inwardly, a shaft extending through the casing, a crank carried by said shaft and connected to said pistons, an intake port

in each of said tubular extensions, a pair of pipes connecting the flanges of opposite tubular extensions, one end of one pipe communicating with the auxiliary chamber of one tubular extension and the same end of the other pipe with the cylinder on the same tubular extension, the opposite ends of said pipes communicating, respectively, with the cylinder and auxiliary chamber, diametrically opposite the first cylinder and auxiliary chamber, a housing for said casing and cylinders, means carried by the housing to control the supply of fuel to the tubular extensions and means for igniting compressed charges within the cylinders.

2. In a gas engine, a housing, a casing rotatably mounted in the housing, tubular extensions arranged in pairs of diametrically opposite members and integral with the casing, a flange on the outer extremity of each of said tubular extensions, flanged cylinders of less diameter having their flanges abutting the flanges of the tubular extensions and secured thereto, a shaft passing through the housing and the casing, a piston in each cylinder having an enlarged portion sliding within the tubular extension and forming an auxiliary chamber around the piston when the piston is moved inwardly, a crank carried by the shaft and connected to the several pistons, a common inlet port carried by the housing, an inlet port in each of said tubular extensions, said inlet ports adapted to register with the inlet port carried by the housing and receive charges of gas therefrom, means to convey the charges of gas from the auxiliary chamber of one tubular extension to the cylinder diametrically opposite said tubular extension, means in each of the cylinders adapted to ignite the compressed charge therein and means carried by the housing adapted to operate said ignition means.

3. In a gas engine a stationary housing, a rotating casing within the housing, tubular extensions integral with the casing and arranged in pairs of diametrically opposite members, cylinders of less diameter carried by said tubular extensions, a shaft passing through the housing and casing, a crank carried by said shaft, a piston in each of the cylinders and connected to said crank, an inlet port in each of said tubular extensions, the inner end of each piston having an enlarged portion to fit the interior of the

tubular extension, whereby an auxiliary chamber will be formed when the piston is moved inwardly, means to connect the auxiliary chamber of one member with the cylinder of the diametrically opposite member, the outward movement of the piston of one member forcing the charge of gas to the cylinder of the diametrically opposite member, an igniter carried by each of the cylinders, a timer carried by the rotating casing, a plurality of contacts carried upon said timer, igniters carried by the cylinders, wires connecting each of said contacts with one of the igniters and means carried by the housing adapted to be engaged by each of the contacts to ignite the charge in each of the cylinders.

4. The combination in a gas engine, of a stationary housing, a rotating casing within the housing comprising integral tubular extensions arranged in pairs of diametrically opposite members, cylinders carried by the tubular extensions, a piston in each of said cylinders, the inner ends of the pistons being enlarged to fit the interior of the tubular extensions, a shaft passing through the housing and the casing, a crank connecting the shaft with the pistons, a valve carried by the housing and comprising a spring pressed block provided with an inlet, the inner face of said block having sliding contact with the outer face of said rotating casing, an intake port in each of said tubular extensions, the inlet in said block being adapted to successively register with the intake ports of the tubular extensions, means to convey the charge of gas from the tubular extension of one of a pair of opposed members to the cylinder carried by the tubular member diametrically opposite, a charge igniting means in each of the cylinders, an electrical contact on the inner wall of the stationary housing and means carried by the rotating casing adapted to contact with said electric contact carried on the stationary housing to successively ignite the charges of gas in the cylinders.

In testimony whereof I have signed my name to this specification in the presence of two subscribing witnesses.

JOHN H. EBERSOLE.

Witnesses:

C. A. NEALE,
A. D. LÖFFLER.