

(19) **DANMARK**

(10) **DK/EP 3635704 T4**



Patent- og
Varemærkestyrelsen

(12) **Oversættelse af ændret
europæisk patentskrift**

-
- (51) Int.Cl.: **G 08 C 17/00 (2006.01)**
- (45) Oversættelsen bekendtgjort den: **2025-03-31**
- (80) Dato for Den Europæiske Patentmyndigheds bekendtgørelse om opretholdelse af patentet i ændret form: **2025-03-19**
- (86) Europæisk ansøgning nr.: **18731031.3**
- (86) Europæisk indleveringsdag: **2018-06-07**
- (87) Den europæiske ansøgnings publiceringsdag: **2020-04-15**
- (86) International ansøgning nr.: **EP2018065102**
- (87) Internationalt publikationsnr.: **WO2018224629**
- (30) Prioritet: **2017-06-08 DE 102017112707** **2017-12-29 DE 102017131462**
- (84) Designerede stater: **AL AT BE BG CH CY CZ DE DK EE ES FI FR GB GR HR HU IE IS IT LI LT LU LV MC MK MT NL NO PL PT RO RS SE SI SK SM TR**
- (73) Patenthaver: **Festool GmbH, Wertstr. 20, 73240 Wendlingen, Tyskland**
- (72) Opfinder: **CASPAR, Moritz, Haussmannstrasse 120, 70188 Stuttgart, Tyskland**
- (74) Fuldmægtig i Danmark: **Zacco Denmark A/S, Arne Jacobsens Allé 15, 2300 København S, Danmark**
- (54) Benævnelse: **Elektrisk indretning som systemkomponent til styring af en støvsuger**
- (56) Fremdragne publikationer:
EP-A2- 2 628 431
DE-A1-102012 003 073
US-A1- 2010 199 453
DE-A1- 102012 003 073
DIN 1EC/TS 61851-3 4, German and English, February 2016
EN 50325-4. December 2002
WO-A1-2016/179271

Electric device as a system component for actuating a vacuum cleaner

The invention relates to an electric device as a first or second system component for a system, according to the preamble of claim 1.

A vacuum cleaner and an energy storage module of this type emerge for example from DE 10 2012 003 073 A1 and EP 2 628 431 A1. The known electric device is
5 for example a battery pack or a machine tool which are connectable together or separable from one another by a plug actuation. It is possible via the battery pack or the energy storage module to actuate a vacuum cleaner arranged remote from the electric device so that it can be switched on or switched off for example.

However, no simple methods are described for favourably establishing the control
10 connection or its separation.

Therefore, the object of the present invention is to provide a simple operating design for an electric device of the type mentioned at the beginning.

In order to achieve the object, an electrical device according to claim 1 and a method according to claim 13 are provided.

15 The electric device is an energy storage module or a machine tool. The machine tool or the vacuum cleaner can be supplied with electric energy by the energy storage module. By simply connecting or separating the energy storage module to/from the machine tool, functions provided for establishing or ending the control connection can be initiated or exercised. It is indeed possible, but not absolutely
20 necessary, that an operator carries out an additional operating action, for example presses or the like a button suitable for authorising or registering the control connection or initiating such authorisation or registration. The corresponding operations are triggered only by plugging in or removing the energy storage module (the

second system component) to or from the machine tool or the vacuum cleaner (the first system component).

When the electric device so to speak is the controlling component, namely the machine tool or the device supplying the machine tool with power, namely the energy storage module, the transition from the separation status to the operating status, 5 for example leads directly to the electric device sending a registration message to establish the control connection to the vacuum cleaner. The separation of the system components from one another can in this connection also be advantageous, namely when for example the energy storage module is separated from the machine tool. In this case, the energy storage module or the machine tool for exam- 10 ple sends a separation message to separate the control connection to the receiving component, here the vacuum cleaner. It is also advantageous in this connection when for example the suction unit of the vacuum cleaner is switched off. Therefore, unnecessary operation or continued operation of the vacuum cleaner is 15 avoided.

The first system component, namely the machine tool, advantageously has a suction connection to connect a suction hose.

When the first system component is a machine tool, it is designed to actuate a vacuum cleaner, which per se does not form a part of the system.

20 However, it should be mentioned at this point that a system according to the invention advantageously comprises an electric device and the respectively other system component such that for example a combination of machine tool and energy storage module is formed. Such a system can be expanded by the vacuum cleaner to be actuated via the control connection.

25 In the case of the electric device, it is advantageously provided that it has at least one sensor to detect the operating status and/or separation status of the device interface.

The at least one sensor can be different types of sensors. Thus, for example a distance sensor can be provided to detect a distance of the system components from one another. Thus, when the device interfaces are arranged at a predetermined distance to one another, the distance sensor, for example an ultrasonic sensor, a tactile sensor or the like, can identify this distance. A plug movement when plugging the device interfaces into one another or the system components into one another can also be sensed or identified by such a distance sensor. Thus, when the plug movement has concluded, a distance is different to when a plug movement has not yet been carried out.

Furthermore, the sensor can comprise a motion sensor to detect a relative movement of the system components to one another. Thus, when for example the system components are no longer moved relative to one another or have only a predetermined movement clearance, this is detected by the sensor. In this way, however, a plug-in movement of the device interfaces into one another can be detected. Thus, when for example the device interfaces are moved towards one another, in particular in the context of a plug movement, the motion sensor can detect such a relative movement. It should be mentioned at this point that the first and the second system component advantageously have such a motion sensor. When the motion sensors detect the same movement pattern, they can for example detect the movement of the device interfaces towards one another and therefore fastening of the first and the second system component to one another. The relative movement, which the motion sensor detects, may be for example a rotational movement and/or a linear movement. The motion sensor can for example be an acceleration sensor.

The at least one sensor can, however, also comprise an optical sensor to detect the respectively other system component or be formed thereby. Thus, for example, it is possible that, when the device interfaces are so to speak mutually shaded or covered, the optical sensor identifies the operating status.

Furthermore, it is advantageous when the at least one sensor comprises an electric switch actuatable by fastening the system components to one another, for ex-

ample a pressure switch, push button or the like. Therefore, a simple actuation design is possible, i.e. that for example one system component actuates the switch, which is arranged on the other system component. This can for example occur as part of a plug movement.

5 It should be mentioned at this point that of course a redundant sensor design is advantageous. When a plurality of sensors report the same connection status of the device interfaces to one another or the system components to one another, thus for example the operating status or the separation status, clear and practically reliable information can be determined from at least two redundant sensor signals
10 as a result.

The device interfaces can expediently be fixed to one another using a fixing device. The fixing device can comprise a plurality of components, for example a catch device, a clamping device, a locking device or the like.

Advantageously, a mechanical actuation element, for example a push button, a
15 sliding button or a sliding actuation element or the like is provided to actuate the fixing device. The fixing device, for example a locking device is actuatable by the actuation element between a fixing position and a release position. The actuation element is preferably actuatable in the direction of the fixing position of the fixing device or the position of the fixing device fixing the system components to one an-
20 other.

At least one sensor to detect an actuation status of the actuation element is arranged on such a mechanical actuation element, for example an unlocking button or the like. An actuation of the actuation element in the direction of a release of the fixing device is assessed or determined by the electric device as a transition from
25 the operating status to the separation status. Consequently, the sensor is thus provided to detect the operating status or the separation status of the device interfaces. When the operator thus releases the fixing device, i.e. actuates the fixing device from the fixing position into the release position, this is detected by the sensor and is evaluated at the same time as a signal for a transition from the operat-
30 ing status into the separation status. Then, a deregistration message is sent to end

the control connection and/or a switch-off signal for a suction unit of the vacuum cleaner is sent. The sensor may for example be an electric switch, an optical sensor, a pressure sensor or the like. Any sensor design suitable for determining the actuation status of the actuation element is possible as such a sensor.

- 5 It is preferably provided that the device interfaces are fixable to one another using positive-locking contours, for example plug projections and plug holders, depressions and projections or the like. For example, a plug holder can be provided on one system component for a plug projection on the other system component.

In the case of the electric device, it is advantageously provided that one device interface has plug positive-locking contours to plug into plug counter positive-locking contours of the other device interface along a plug axis and electric contacts for contacting with electric counter contacts of the other device interface for an electric connection of the system components, which enter into electric contact with one another in the case of a plug-in assembly of the plug positive-locking contours and the plug counter positive-locking contours. Therefore, the electric contacts, for example energy supply contacts and/or data contacts, in the case of the plug-in assembly, enter into contact with one another directly. The contacts may for example be spring contacts, contact tabs, contact surfaces or the like. The plug positive-locking contours and the counter plug positive-locking contours comprise for example guide ribs, plug holders and plug projections, guide grooves and/or the like. Combinations are readily possible.

It is preferred when the device interface comprises a data interface, in particular a bus interface. The data interface is for example a bus interface, in particular I²C interface. The energy storage module can exchange data with the machine tool or the vacuum cleaner via the data interface. Thus, for example the number of storage cells, a maximum available electric power, electric capacity or a charging status or the like can be queried via the data interface. Switching signals, in particular to switch off the energy storage device or the machine tool or the vacuum cleaner or the vacuum cleaner can also be conveniently transmitted via the data interface.

30 The data interface can, however, also comprise a parallel data interface, i.e. such

that a plurality of data contacts in each case provided dedicatedly for information are provided.

According to the invention, it is provided that the electric device is designed to identify the operating status and/or separation status, i.e. of a connection status of the device interfaces to one another, using data transmission via the data interface. Thus, for example when the energy storage module is asked so to speak by the machine tool or the vacuum cleaner at the start of operation what electric characteristic data is available so that the subsequent operation of the vacuum cleaner or the machine tool can be optimally configured, this is a signal to establish the operating status. This can for example be used by the energy storage module, serving as part of the machine tool, to establish the control connection. However, when the data transmission is interrupted, for example due to a separation of energy storage module and vacuum cleaner or machine tool, this can also be evaluated as an indicator, namely for a starting or already started separation status. In this case, the device according to the invention removes the control connection for example and/or sends a switch-off signal for the suction unit of the vacuum cleaner or the like.

The data transmission can also be a data transmission provided specifically to monitor the separation status.

At least one verification message, in particular verification message suitable exclusively for verification is preferably provided to identify the operating status or separation status or both. The verification message can be a unidirectionally sent message, for example a verification message sent by the vacuum cleaner or the machine tool, using which the energy storage module can identify whether it is connected to the vacuum cleaner or the machine tool. A dedicated communication means, for example a special controller can be provided to send the verification message. It is also possible that for example one device sends a verification message, in particular the energy storage module and identifies using a response to the verification message that it is connected to a respectively other device, for example a vacuum cleaner or a machine tool. Consequently, the separation status or

operating status can thus be verified since both a verification message and a response to the verification message are sent and received. The at least one verification message is preferably sent cyclically and/or in predetermined time intervals.

It is preferred when the electric device is designed for an authentication when the control connection is established. The authentication comprises for example the sending of an identification parameter, an access password or the like.

Furthermore, it is advantageous when the communication interface is designed for encrypted communication via the control connection. The encryption can for example be a Diffi-Hellmann encryption.

The communication interface is for example a Bluetooth interface, a WLAN interface or the like. A communication in a defined space for example in the range of up to approx. 10 m or 20 m, i.e. the typical length of a suction hose or a suction connection is in particular advantageous.

It is preferably provided that the energy storage module has a module housing and an energy storage device received in the module housing, in particular an arrangement with at least one rechargeable electric storage cell to provide electric energy for the energy supply of the machine tool or the supply contacts provided for the vacuum cleaner. The electric storage cells, in particular a grouping or an arrangement of a plurality of electric storage cells are for example chargeable by a charging device. However, it is also possible that the energy storage device has for example a fuel cell or the similar other electric storage device or chemical storage device which can provide electric energy at the end.

The energy storage module expediently has a module housing with a device interface for the detachable connection to the machine tool. The device interfaces of the energy storage module to the machine tool or the vacuum cleaner have supply contacts suitable for one another to transfer electric energy and/or data contacts, in particular bus contacts to transmit data.

The machine tool is a machine tool generating dust and/or particles, for example a sawing machine, a drilling machine, a milling machine, a grinding machine or the like. In particular, the machine tool is a hand-held machine tool. The machine tool expediently has a suction outlet, for example a connection fitting to connect a suction hose.

The vacuum cleaner could also be generally designated as a vacuum device. The vacuum cleaner can itself of course not only vacuum dust, but rather also coarser particles which the machine tool generates.

It is preferred for the control connection to only be establishable or established when the vacuum cleaner and the machine tool are flow-connected to one another using the suction hose or a suction hose.

Sensors or detection means can be provided on the machine tool and/or the vacuum cleaner which identify the connection of the suction hose. Only if a suction hose is actually connected, will the control connection be established.

In the case of the energy storage module, it is advantageous when it obtains one or a plurality of received information items, in the case of the transition from the separation status to the operating status, via a data interface of the device interface, for example a bus interface, from the other system component, the vacuum cleaner or the machine tool. For example, the energy storage module can request the received information at the machine tool or the vacuum cleaner or the machine tool or the vacuum cleaner can send the received information without previous request to the energy storage module. The received information preferably comprises at least one status information item, for example error information, switching information of a switch, for example a potentiometer, an on-switch or an off-switch or the like, of the vacuum cleaner or the machine tool and/or at least one identification information item, for example a serial number of the vacuum cleaner or the machine tool.

One or a plurality of predetermined received information items received from the vacuum cleaner or the machine tool via the data interface, in particular non-security-related and/or non-confidential received information, can readily be sent, in particular unencrypted, as part of a broadcast communication, advertising communication or the like by the energy storage module via its wireless communication interface. Thus, for example a smartphone or another external communication apparatus can receive status information, at least one identification information item or the like of the vacuum cleaner or the machine tool via the energy storage module.

Embodiments of the invention are explained below using the drawings. These show:

Figure 1 a perspective oblique view of a system according to the invention comprising a hand-held machine tool and a vacuum cleaner,

Figure 2 a partial view roughly corresponding to a detail D1 of the vacuum cleaner according to Figure 1,

Figure 3 a perspective oblique view of a communication module of the vacuum cleaner according to Figure 1,

Figure 4 a device interface of a machine tool according to Figure 1,

Figure 5 an energy storage module of the system according to Figure 1 represented in a perspective oblique manner,

Figure 6 the energy storage module according to Figure 5 represented perspectively from another side,

Figure 7 a charging device to charge the energy storage module according to Figures 5, 6,

Figure 8 a communication module of the system according to Figure 1 in a perspective oblique view,

- Figure 9 the communication module according to Figure 8, but with a fastening device for fastening on a schematically represented suction hose,
- Figure 10 a schematic functional representation of the communication module
5 according to Figure 9, 10,
- Figure 11 a schematic circuit diagram of the energy storage module and a hand-held machine tool and a communication module according to Figure 1,
- Figure 12 a schematic circuit diagram of the energy storage module according
10 to Figure 4 in cooperation with the charging device according to Figure 7,
- Figure 13 a perspective representation of the other energy storage module according to Figure 1 in the status put on the charging device according to Figure 7,
- 15 Figure 14 a communication diagram between the vacuum cleaner according to Figure 1 and an energy storage module,
- Figure 15 a schematically represented system with a vacuum cleaner arranged in a transport box and operable with an energy storage device,
- Figure 16 a diagram with a relation between signal strength information and a
20 response time.

Identical and similar components are provided below in part with the same or similar reference numerals marked with the addition of A, B etc.

A system 10 partially schematically represented in Figure 1 comprises machine tools 20A, 20B which are supplied with electric energy by energy storage modules
25 40A, 40B. The machine tools 20A, 20B are machine tools generating dust or parti-

cles and in particular hand-held machine tools. The machine tool 20B is for example a grinding device, the machine tool 20A is a saw, in particular a jigsaw, with a router or similar other electric machine tool or hand-held machine tool generating dust or particles also being readily possible.

- 5 A drive motor 22 is arranged in a machine housing 21A, 21B of the machine tool 20A, 20B which is provided to drive a tool holder 23A, 23B and therefore a tool 38A, 38B arranged on the tool holder 23A, 23B. The tool 38A is for example a sawing tool, the tool 38B is a grinding pad. The drive motor 22 can drive the tool 238A, 38B directly or via a gear, e.g. a gear 22A for an oscillating movement.
- 10 The machine tool 20A, 20B can be switched on and switched off using a switching element 24, for example an on-switch/off-switch. A further switching element 25 is for example designed as a speed regulator or speed controller. An embodiment is possible in the case of which for example the speed of the drive motor 22 is modifiable by a corresponding actuation stroke of the switching element 24.
- 15 The hand-held machine tool 20A, 20B has a control device 26 to actuate the drive motor 22. The control device 26 for example comprises a processor 27 and a memory 28. A program module or a plurality of program modules 29 are stored in the storage device 27, whose program code is executable by the processor 27 in order to control the hand-held machine tool 20A, 20B and/or to communicate with
- 20 the energy storage modules 40A, 40B.

The machine tool 20A, 20B has a suction connection or suction outlet 39 to connect a suction hose 15 via which dust occurring during the operation of the tool 38A, 38B can be suctioned. The suction outlet 39, for example a connection fitting, communicates with suction openings arranged on or in the tool 38B, which are not

25 visible in the drawing. Therefore, dust can be suctioned directly away from the tool 38A, 38B in a normal manner known per se.

A vacuum cleaner 70 of the system 10 has a vacuum housing 71 which can be put and/or is rollable for example on rollers 71A, 71B on a floor. The vacuum device 70 is a mobile vacuum device. The vacuum cleaner 70 could, however, also have

the shape of a stackable vacuum cleaner, consequently a stack housing and/or have a box shape. The rollers 71A, 71B are optional.

The vacuum cleaner 70 has on the front side of the vacuum cleaner housing 71 a suction inlet 72 to which the suction hose 15 is connectable. The suction hose 15 extends with a longitudinal end 16, which is connected to the suction outlet 39A, and another longitudinal end 17, which is connected to the suction inlet 72, between the machine tool 20A and the vacuum cleaner 70. The machine tool 20B is connected via a branch 18 of the suction hose 15 to the vacuum cleaner 70. The branch 18 branches to the longitudinal end 16 and to a longitudinal end 19 which is connected to the suction outlet 39A of the machine tool 20B. Of course, the branch 18 of the suction hose 15 is optional. A suction hose can also be provided in a manner known per se which extends directly between a suction outlet 39 and the suction inlet 72, without having a branch.

A dirt collection chamber 73 is provided in the vacuum housing 71 in which dust and other particles can be received from a vacuum flow S, which is suctioned via the suction outlet 72. A filter 74 is preferably provided above the dirt collection chamber 73. However, a filter sack can also be arranged in the dirt collection chamber 73 in addition to or instead of the filter 74 which is suitable for collecting dirt and particles. The already mentioned vacuum flow S, which is suctioned through the suction inlet 72, can be generated by a suction unit 75. The suction unit 75 is for example supplied with electric power using a mains connection device 76. The mains connection device 76 for example comprises a connection cable and a connection plug to connect to an electric supply network EV, in particular with 220 V or 110 V alternating current.

The functions of the vacuum cleaner 70 are controllable by an operating element arrangement 77. The operating element arrangement comprises for example a switching element 78, by means of which the vacuum cleaner can be switched on or switched off or switched into automatic operation, in the case of which for example a current guided via an outlet 79 leads to the suction unit 75 switching on and

switching off. The outlet 79 is expediently provided on the operating element arrangement 77. An electric consumer, preferably an electric hand-held machine tool 20C can be connected in the outlet 79.

The outlet 79 has contacts 80, in particular bushes into which contacts 32C of a plug 31C of the hand-held machine tool 20C are insertable. The plug 31C is arranged on a connection cable which is a part of a mains connection device 30C. If an operator actuates a switching element 24 of the hand-held machine tool 20C to power its drive motor 22, with which for example a saw blade is drivable, current flows via the mains connection device 30C, which is provided by the vacuum cleaner 70 via the outlet 79. This current is detectable by a current sensor 81 in a manner known per se. A control device 86 of the vacuum cleaner 70 switches on the suction unit 75 in the case of a current flow via the outlet 79 in a manner known per se and at the end of the operation of the hand-held machine tool 20C, i.e. when the current sensor 81 no longer determines a current flow, switches off the suction unit 25, expediently with a stopping time.

The current sensor 82 is for example connected to an input/output interface 82 of the control device 80. The input/output interface 82, for example a power electronics interface further serves to actuate the suction unit 75.

The control device 86 further has a processor 87 and a memory 88 in which one or a plurality of program modules 89 are stored. The at least one program module 89 has a program code which is executable by the processor 87 and, amongst other things, enables one or a plurality of the following functions.

The outlet 79 is connectable via the vacuum cleaner 70 to the supply network EV or also connectable directly to the supply network EV, namely using the mains connection device 30C.

The machine tools 20A, 20C in contrast are equipped for a cableless or wireless operation. They can namely be supplied with electric power using the energy storage modules 40A, 40B.

The energy storage modules 40A, 40B are constructed functionally similarly, with mechanical differences and/or electric differences possibly readily existing with regards to the power supply capacity, voltage or the like.

5 The energy storage modules 40A, 40B have module housings 41A, 41B in which energy storage devices 42 are arranged. The energy storage devices 42 have one or a plurality of storage cells 43, in particular a storage cell arrangement with a plurality of storage cells 43 which are rechargeable.

10 Using a display device 44, which is optionally present in the case of the energy storage module 40A, a charge status of the energy storage device 42 can be output, for example acoustically and/or optically. The display device 44 for example comprises a speaker 44A, which can signal a low charge status, e.g. using a warning tone. In the case of the display device 44, an arrangement of one or a plurality of lights 45 is preferred, for example lights 45A, 45B, 45C and 45D. The lights 45A-45D are preferably LEDs.

15 The functions of the energy storage modules 40A, 40B are controllable by control devices 46.

The control devices 46 can be supplied with electric energy directly by the energy storage device 42 and/or one or a plurality of the storage cells 43. For example, supply lines 42X can be provided between the energy storage device 42 and the control device 46. A control device 46 can also have a supply module 46X to adapt a voltage provided by the energy storage device 42 or a supply current provided by the energy storage device 42. Therefore, a respective control device 46 can be supplied with electric energy locally, irrespective of whether the energy storage module 40 is connected to an electric device, for example a charging device or a machine tool or a vacuum cleaner.

20
25

The control devices 46 for example have a processor 47 and a memory 48 in which at least one program module 49 is stored. For example, the control device 46 can communicate with the control device 26 of the hand-held machine tool 20A,

20B. The processor 47 can execute program code of the program modules 49, amongst other things to implement the functions explained in detail below.

The energy storage modules 40A, 40B are detachably connectable to one another with the machine tools 20A, 20B using device interfaces 30 of the machine tools
5 20A, 20B and device interfaces 50 of the energy storage modules 40A, 40B.

The machine tools 20A, 20B form first system components 11, the energy storage modules 40A, 40B second system components 12, which are fixedly connected to one another such that they in each case form a system.

The device interfaces 30, 50 comprise, to this end, contours fitting together in a
10 positive-locking manner, for example to form positive-locking contours suitable for rotary locking or as in the present case plug positive-locking contours 51 on the device interface 50, which can engage the device interfaces 30 in a positive-locking manner with plug counter positive-locking contours 31, namely in the context of a plug movement.

15 Using this plug movement, device supply contacts 32 of the device interface 30 enter into contact with supply contacts 52 of the device interface 50 such that electric energy from the energy storage device 42 can be provided via the supply contacts 52, 32 for the respective machine tool 20A, 20B, in particular its drive motor 22.

20 The device interfaces 30, 50 further comprise data contacts 33, 53 of data interfaces 34, 54 such that even data communication, in the present case in particular a bus communication between the system components 11, 12, is possible.

A fixing device 55 provides additional hold for the positive-locking design using the plug positive-locking contours 51, 31 by means of which the system components
25 11, 12 are fixable to one another. The fixing device 55 for example comprises a fixing element 56, in particular a catch, a latching element or the like which can be engaged with a fixing contour 35. The fixing contour 35 and the fixing element 56

are arranged on the first system components 11 and the second system components 12, with the reverse configuration also being readily possible. The fixing device 55 forms, in the present case, a locking device and/or catch device. The fixing element 56 can, using an actuation element 57, be disengaged, optionally also engaged, with the fixing contour 35. For example the fixing element 56 is a fixing projection/locking projection, which can be engaged with the fixing contour 35 designed as a fixing holder or depression. If the fixing device 55 engages its fixing position or locking position, the plug positive-locking contours 51 remain engaged with the plug counter positive-locking contours 31, i.e. a relative movement of the system components 11, 12 along the plug axis of the plug positive-locking contours 51, 31 is not possible.

The actuation element 57 and/or the fixing element 56 are spring-loaded by a spring arrangement (not visible) into the fixing position or locking position. Therefore, the fixing device 55 can be moved out of the fixing position into the detached position by simple pressure actuation or button actuation of the actuation element 57. In each case, one fixing element 56 is preferably provided on the energy storage module 40A on sides opposed to one another, also in each case one actuation element 57 is necessary, while in the case of the energy storage module 40B only a single push button or a single actuation element 57 is necessary.

The energy storage modules 40A, 40B can be charged using a charging device 220. The charging device 220 has a charging device housing 221 on which a device interface 230 is provided. The device interface 230 has plug counter positive-locking contours 231 which are compatible in a positive-locking manner with the plug positive-locking contours 51 of the energy storage modules 40A, 40B. Locking is not necessary for stationary operation. Fitting the device interface 50, the charging device 220 further has device supply contacts 232 and data contacts 233 of a data interface 234, preferably a bus interface. A voltage transformer 235 is preferably arranged in the charging device 220, which can be supplied with electric power using a mains connection device 236 and provide a direct voltage at the device supply contacts 232 to charge the energy storage device 42. The connection plug 237 forms a part of a mains connection device 236 and can be arranged directly on the charging device housing 221 or be connected via a line, which is

schematically represented, to the charging device housing 221. The connection plug 237 is connectable to the supply network EV.

The data interfaces 34, 54 and 234 are bus interfaces in the present case. For example, the bus interfaces or data interfaces 34, 54, 234 are I²C bus interfaces. The bus interfaces comprise a clock line CL, a data line D and a supply line VD, to which data contacts 33A, 53A and 234A are assigned, a clock line CL, to which data contacts 33B, 53B and 233B are assigned, and a data line D, to which data contacts 33C, 53C, 234C are assigned. The supply line VD is used so that the device interface 30 or 230 of the device interface 50 provides an electric supply voltage, for example a bus voltage UB. A bus clock of the bus BU implemented on the data interfaces 34, 54, 234 is provided via the clock line CL. Data is transferred via the data line D, preferably bidirectionally from the energy storage module 40 to the machine tool 20 and vice versa and/or from the energy storage module 40 to the charging device 220 and vice versa.

If the system components 11, 12 are connected to one another, the energy storage module 40 provides a supply voltage UV to the supply contacts 52A, 52B which is suitable for operating the drive motor 22. The supply voltage UV is for example a direct voltage of 15 volts or 18 volts, but can also be another voltage at any time. It should be mentioned at this point that an energy supply module could of course also provide an alternating voltage. This is not essential. The control device 26 of the machine tool 20A, 20B, simply designated below as the machine tool 20, actuates, as a function of an actuation of the switching element 24, the drive motor 22, with it opening or closing for example a switch 24A. Instead of the switch 24A, a power electronics, for example an energisation device can also be provided for an electronically commuted drive motor 22. Furthermore, it is conceivable for the switching element 24 to be switched directly into the current circuit of the drive motor 22 and therefore to be able to switch it on and off. If the switch 24A is closed, the current flows from the energy storage device 42 via a line L1 to the drive motor 22 and from said drive motor back via a line L2 to the energy storage device 42.

In the case of a charging operation, this current flow design is precisely the reverse, which is clear from Figure 12. A charging current I_L flows in this case from the voltage transformer 235 via the line L1 to the energy storage device 42. The supply contact 232B is, just like the supply contact 52, assigned to a line L2, for example to an earth line. The charging operation is preferably controlled by a control device 226 of the charging device 220. The control device 226 can for example actuate the switch 238 in order to begin or end the charging operation. In order to monitor the charging operation, the charging device 220 also communicates with the energy storage module 40, namely via the data interface 234 and the data contacts 233A, 233B and 233C assigned thereto for the supply line VD, the clock line CL and the data line D. The charge status of the energy storage device 42, its nominal voltage or the like can for example be requested by corresponding communication on the bus BU between the charging device 220 and the energy storage module 40. In order to control and monitor the charging operation, the charging device 234 has for example a processor 27 which can execute control commands or program code of a program module 229 to control the charging operation. The processor 227 is connected to a memory 228 of the control device 226 of the charging device 220 in which the program module 229 is stored.

The vacuum cleaner 70 is actuatable in a wireless or cableless manner. To this end, the vacuum cleaner 70 has an integral external communication apparatus 100 or an external communication apparatus 100 preferably designed as a module. The external communication apparatus 100 is detachably arrangeable in a module holder 90 of the vacuum cleaner housing 71. The module holder 90 is for example arranged in the region of the operating element arrangement 77, in particular a front wall 95 on which the operating element arrangement 77 is provided. When the communication module in the shape of the external communication apparatus 100 is inserted into the module holder 90, contacts of contact arrangements 90, 101 of the module holder 90 and the communication apparatus 100 enter into contact with one another. Therefore, data, information, electric supply voltage and the like can be transmitted. For example, the control device 86 supplies the external communication apparatus 100 with the electric supply voltage via the contact arrangement.

Furthermore, a data interface 83 of the control device 86 and a data interface 108 of the external communication apparatus 100 are in contact with one another using the contact arrangements 101 and 91. The data interfaces 83, 108 for example comprise a bus interface, via which the external communication apparatus 100 and the control device 86 can communicate data and information.

The data interfaces 108, 83 for example implement a bus connection, in particular an I²C bus connection. Other bus communications are also possible. Furthermore, the data interfaces 83, 108 can also comprise individual data contacts, for example for a parallel data transmission.

The module holder 90 comprises side walls 92 which extend from a bottom 93 of the module holder 90 to the front wall 50. In the module holder 90, i.e. in the internal space between the side walls 92 and the bottom 93, the contact arrangement 101 protruding from a rear side 103 of a front wall 105 of the external communication apparatus 100 can engage into the contact arrangement 91 arranged on the bottom 93 of the module holder 90 or enter into contact therewith. Side wall surfaces 101 of the front wall 105 are then aligned with the side walls 92 such that a forward side or the front wall 105 of the external communication apparatus 100, as represented in Figure 1, is aligned with the front wall 95. The plug connection of the module of the external communication apparatus 100 in the module holder 90 alone ensures a reliable hold. A fixing device for example a catch device, clamp device or the like not represented in the drawing is preferably provided for further fixing. In the present case, a screw connection is provided. For example, one or two screw holders 94 are provided on the module holder 90 which align with screw holders 104 of the external communication apparatus 100 when this is received in the module holder 90. Screws indicated in Figure 1 can be screwed into the screw holders 104, 94.

The vacuum cleaner 70 can be actuated in a wireless and/or cableless manner using the external communication apparatus 100, for example by a wireless communication interface 60 of the energy storage module 40A or 40B.

It should be mentioned at this point that the wireless communication interface 60 is to be provided by way of example for a wireless actuation of the systems comprising the system components 11 and 12, namely in each case an energy storage module and a machine tool. Thus, the machine tool 20C can for example be
5 equipped with a wireless communication interface 60C in order to directly perform one or a plurality of communication functions still to be described below, i.e. without a respective energy storage module 40, which a wireless communication interface, communicating wirelessly with the vacuum cleaner 70.

The external communication apparatus 100 can be switched, using a registration
10 operating element 160, into a standby mode from an operating mode in which a control connection with the external communication apparatus 100 can be newly established or re-established.

The standby mode or the operating mode are optically and/or acoustically signalled by the external communication apparatus 100. For example, a display device 114 is provided which can signal different operating modes of the external
15 communication device 100. The display device 114 for example comprises a light display, in particular a circular light display. The display device 114 is for example arranged around or on the registration operating element 106. The registration operating element 106 is for example a button 107 around which the display device
20 114 preferably circularly extends.

When the display device 114 permanently illuminates, it signals an established control connection, i.e. the status "connected". When the external communication apparatus 100 is switched, using the registration operating element 106, from the operating mode into the standby mode, the display device 114 illuminates for ex-
25 ample in another colour or with another movement pattern, in particular with a slow, circulating movement pattern. This movement pattern or the colour of the display device 114 can be independent on the type of control connection. When a control connection, as explained below, is a control connection to be currently established and/or a temporary control connection already established, the display
30 device 114 can for example have a slow circulating light display. When, however, a control connection is permanently established or to be established, i.e. the

standby mode is suitable for establishing a permanent control connection, the display device 114 illuminates differently. For example, the circular illumination of the display device 114 then takes place at a higher frequency.

For a permanent control connection, a e.g. communication module 300 is provided, which preferably forms a system component of the vacuum cleaner 70, is
5 connected to the external communication apparatus 100.

The communication module 300 is a communication module arranged or arrangeable outside of the vacuum housing 71. The communication module 100 serves to maintain and/or establish a control connection of the electric device in the shape of
10 the system components 11 and/or 12 with the vacuum cleaner 70, in particular the external communication apparatus 100.

The communication module 300 has a module housing 301 which can be placed on the suction hose 15. The module housing 301 expediently has on its upper side
15 302 a switching element 334 with which the suction unit 75 can be switched on and/or off. The switching element 334 takes up the majority of the upper side 302 in an ergonomically favourable manner such that it is easy to operate or actuate. The switching element 334 is for example a push button, rocker switch or the like.

The module housing 301 has a shape adapted to the suction hose 15. For example, an underside wall 306, which, in the status of the communication module 300
20 installed on the suction hose 15, comes to rest on its outer circumference, has a round contour adapted to the round outer circumference of the suction hose 15. A forward side wall 303, a rear side wall 304 and longitudinal side walls 305 extend between the underside wall 306 and the upper side or upper side wall 302. They delimit an internal space in which a control device 336 of the communication mod-
25 ule 300 is arranged in a supported manner.

The control device 336 for example has a processor 337, a memory 338 and at least one program module 339 which comprises program code which can be executed by the processor 337 to perform the functions of the communication module 330, which will be explained later.

In order to install the communication module 300 on the suction hose 15, hooks 301 are provided on the longitudinal side walls 305. Consequently, the module housing 301 thus has in each case one hook 307 at sides opposed to one another. Each hook 307 has a hook projection 308 and a hook depression 309. The hooks 307 serve to fasten a hose bracket 320 (70, 870 figure 8) for example of a clamping point 321. The hose bracket 320 has on its longitudinal end regions 322 in each case hook holders 323 which can be engaged with the hooks 307. Of course, other fastening technologies are also possible, for example by means of an adhesive strip or the like. Integration of a communication module 300 on the longitudinal ends 16 and/or 17 of the suction hose 15 may also be conceivable, for example when corresponding tubular bodies are provided, e.g. connection pieces or connection fittings made from rubber, plastic or the like. The communication module 300 can, however, also be adhered, welded on the suction hose 15 or similarly otherwise connected to the suction hose 15. However, this is irrelevant for the communication functions of the communication module 300. The ergonomically favourable arrangement on the suction hose 15 is also advantageous.

To switch the external communication apparatus 100 from the operating mode to the standby mode, a registration operating element 316 is provided. The registration operating element 316 for example comprises a button 317. The functions of the registration operating element 316 correspond to those of the registration operating element 106 such that the operator so to speak finds the same operating design.

Accordingly, a display device 314 is also designed identically or similar to the display device 114. The display device 314 for example comprises a light display which signals information in relation to the establishment and/or presence of a control connection between the communication module 300 and the external communication apparatus 100.

When an operator for example actuates the registration operating element 316, in particular pushes the button 317, a communication interface 311, in particular a Bluetooth interface, a WLAN interface or the like sends a corresponding control signal, in particular a switching message SN to the communication interface 110 to

switch to the standby mode. As a result, the external communication apparatus 110 is switched to a standby mode which the display device 314 signals. An actuation of the registration operating element 316 leads to the external communication apparatus 100 switching from the operating mode to the standby mode. In order to send the control signal, an encrypted and/or authenticated connection is preferably provided between the communication module 300 and the external communication interface 110.

When the switching element 334 is actuated, the communication module 300 sends a start command or switch-on command for the suction unit 75 to the external communication apparatus 100 and consequently to the control device 86 of the vacuum cleaner 70. Using a switching element 335, for example a rotary element, a sliding element or the like, the communication module 300 can send a control command to the external communication device 100 and therefore to the vacuum cleaner 70, with which for example the speed of the suction unit 75 and/or its power can be adjusted. Consequently, the communication module 300 can serve as a remote control for the suction unit 75. A secured and/or encrypted control connection between the communication module 300 and the external communication apparatus 100 is also advantageous for the remote control functions.

Since the communication module 300 forms a system component of the vacuum cleaner 70, a control connection from the communication module 300 to the external communication apparatus 100 is a so to speak permanent control connection. Such a control connection requires a higher degree of difficulty to establish it than a control connection between a system component 11 or 12 and the vacuum cleaner 70. Accordingly, for example the registration operating element 106 and/or 316 must be actuated for longer in order to authorise or register the communication module 300 at the vacuum cleaner 70 or the external communication apparatus 100. A registration procedure to establish a control connection between one of the system components 11 or 12 for example the energy storage module 40 and the external communication apparatus 100 is, in contrast, easier to establish, for example using a shorter actuation of the registration operating element 106 and/or 316.

The machine tools 20A, 20B communicate using the energy storage modules 40A, 40B with the vacuum cleaner 70 and can actuate it via control connections S1 and S2. However, control commands cannot be sent directly via the control connections S1, S2, but rather only after a previous registration/authorisation of the machine tools 20A, 20B at the external communication apparatus 100. Consequently,
5 the respective control connection S1, S2 must firstly be established before it is available for the transmission of control commands and/or status signals between the components 20A, 70 or 20B, 70 remote from one another.

The configuration is in this case made such that the machine tools 20A, 20B do
10 not communicate directly wirelessly with the vacuum cleaner 70, but rather using the energy storage modules 40A, 40B assigned to them and attached to them. However, it is certainly possible that the communication described below in relation to the wireless communication interface 60 is also implementable with a at the machine tool 20B, namely for example directly (not represented), similar to the
15 control connection S2 or indirectly via the communication modules 300B and 300C, as will be clearer.

Essentially, the energy storage modules 40A, 40B form so to speak gateways for the machine tools 20A, 20B for wireless communication, in particular in the control direction, i.e. from the machine tool 20A, 20B to the vacuum cleaner 70. However,
20 the reverse communication direction from the vacuum cleaner 70 to the machine tools 20A, 20B is also possible via the gateways 40A, 40B.

In order that these functions are particularly easy to implement, the energy storage modules 20A, 20B are smart such that they can identify for example whether they are connected to a device requiring wireless communication with the vacuum
25 cleaner 70 or a device even implementing such communication or to another device, for example a machine tool, which is not suitable for the vacuum cleaner operation, for example a screwing device, a gluer or the like. In particular, the energy storage modules 40A, 40B can detect whether they are connected to the charging device 220.

The charging device 220 sends, namely for example via the bus interface BU, a request message 700 to the control device 46 with which it requests the current charge status of the energy storage device 42, the status and/or the maximum charge voltage for the storage cells 43, maximum charging currents or the like.

5 The control device 46 responds with a response message 701 in which the corresponding information is stored. Using the quality of the request message 700, namely for example the fact that a level of a maximum permitted charging current is requested, the energy storage module 40 identifies that it is connected to a charging device and not to an electric consumer in the manner of the machine tool
10 20A or 20B which requires a wireless communication connection to a vacuum cleaner.

However, other information can also be evaluated by the energy storage module 40 to recognise the connection to a charging device in the manner of the charging device 220. Thus, a charging voltage U_L , which is provided by the charging device
15 220, is higher than a supply voltage U_V , which is applied at the connection of an electric consumer between the lines L1 and L2 or the supply contacts 52A, 52B.

The control device 46 is supplied with electric energy via the bus interface or data interface 54. The supply voltage U_{B2} applied at the supply line VD or the data contact 53A, which is provided by the charging device 220, differs in its voltage
20 level from the supply voltage U_{B1} , which the electric hand-held machine tool 220 provides at the data contact 53A. The supply voltage U_{B1} is for example 3 volts, the supply voltage U_{B2} 5 volts.

For example, a voltage measuring device 61, in particular a voltage sensor, resistance circuitry or the like is provided at the data interface 54 to detect the differ-
25 ent voltage levels of the voltages U_{B1} and U_{B2} such that the control device 46 can identify whether it is connected to a charging device (charging device 220) or to an electric consumer or an electric machine tool in the manner of the machine tools 20A, 20B.

It is possible that the control device 46, depending on whether the energy storage
30 module 40 is connected to a machine tool 20 or to the charging device 220,

changes an operating mode of the wireless communication interface 60. For example, the control device 46 activates the wireless communication interface 60 when the energy storage module 40 is connected to a machine tool 20, while it deactivates the wireless communication interface 60 when the energy storage module 40 is connected to the charging device 220.

It is also possible that the control device 46 does not deactivate the wireless communication interface 60, when the energy storage module 40 is connected to a machine tool 220, but changes the communication mode. Thus, the wireless communication interface 60 can for example remain active for communication with the configuration device 500 still to be explained, in particular a smartphone when the energy storage module 40 is not connected to the machine tool 20, for example is connected to the charging device 220 or has no such connection. Using the configuration device 500, for example the smartphone, program data or the like can for example be transmitted to the energy storage module 40, even if this is not connected to the machine tool 20.

However, when the energy storage module 40A or 40B is connected to the machine tool 20A or 20B, the wireless communication with the vacuum cleaner 70, in particular its external communication apparatus 100 is easily possible without problems.

A function and communication process 400 begins for example with an operating action 401 of an operator N. The operator N of the system 10 connects for example the vacuum cleaner 70 to the supply network EV or actuates the switch or the switching element 78 such that the vacuum cleaner is essentially operationally ready, i.e. has a function 410 "status in operation".

A control device 117 of the external communication apparatus 100 switches at this point into a status 411 in which the external communication apparatus searches for devices already authorised to actuate the vacuum cleaner 70. This status 411 lasts for example a predetermined time, in particular one minute or two minutes, after which it ends once again. This time limitation is an option that reduces the risk of unauthorised access to the vacuum cleaner 70.

In order to perform this functionality and the following functionalities, the control device 116 has for example a processor 117 to execute the program code of a program module 119 which is stored in a memory 118 of the external communication apparatus 100.

5 A function 412 of the program module 119 enables for example the detection of information of the registration operating element 106. Thus, if the operator for example in a step 413 actuates, in particular presses the registration operating element 106, the registration operating element reports the function 412 using an output command 414 to the operator N by it namely actuating the display device 114
10 such that the operator sees that the external communication apparatus 100 and therefore the vacuum cleaner 70 is ready to establish new control connections. The external communication apparatus 100 goes into a status 415, namely into an operation standby mode in which a control connection can be established with the external configuration apparatus 100.

15 The communication module 40 is thus inactive at the start of the function and communication process 400 in a status 430 "sleep". Proceeding therefrom, a number of scenarios are possible to establish one of the control connections S1 or S2, of which a first scenario is described below:

The operator N actuates for example the switching element 24 of the machine tool
20 20A in order to switch it on. The machine tool 20A or the assigned energy storage module 40A is still, however, not authorised to output switching commands or control commands to switch on the suction unit 75. Such a registration or authorisation, however, occurs automatically so to speak when the operator N simply actuates the switching element 24.

25 If the operator N actuates the switching element 24, the communication relation between the machine tool 20A and the energy storage module 40A is actively switched and/or established. The energy storage module 40, thus each of the energy storage modules 40A, 40B identifies from operational information coming from the actuation of the switching element 24 that a device suitable for establishing
30 and using a control connection is connected to the device interface 50.

The energy storage module 40 can thus for example identify using the supply voltage UV that an electric consumer is connected. The voltage UV differs from the voltage UL of the charging device 220.

Further operational information can for example also be the supply voltage UB1
5 which is provided by the control device 26 to the supply line VD or the data contact 53a. The supply voltage UB1 differs from the supply voltage UB2 of the charging device 220, it is in particular lower than it. Therefore, the supply voltage UB1 thus also forms an indicator of an actuation of the switching element 24.

Furthermore, an initialisation communication can be evaluated on the bus BU from
10 the control device 46 as an indicator of the activation of the data interface 54 by a device actuating the vacuum cleaner 70, i.e. the machine tool 20A or 20B (designated below only as machine tool 20). Thus, for example a request message 750 can be sent from the control device 26 to the control device 46, with which for example a supply voltage UV of the energy storage module 40, which can be pro-
15 vided, is queried. In the request message 750, however, data identifying the electric device or the machine tool 20 may be contained, for example an identifier 751 which characterises the machine tool 20A, 20B as a machine tool requiring dust extraction. The request message 750 for example represents operationally ready information of the machine tool 20. With a response message 752, the control de-
20 vice 46 responds to the request message 750 and provides the requested information and/or information, for example charge status of the energy storage module etc.

Coming from the actuation of the switching element 24, the energy storage module 40 sends via the wireless communication interface 60 in a function 431, for exam-
25 ple the program module 419, in the context of a transmission operation 432, a registration message 440 to the external communication apparatus 100.

The registration message 440 comprises for example a broadcast transmission identifier 44x, i.e. a registration message, which is directed to a plurality of essentially ready-to-receive vacuum cleaners, not only the vacuum cleaner 70. Further-
30 more, an authorisation parameter 442 is optionally indicated in the registration

message 440. The authorisation parameter 442 comprises for example an essential system compatibility of the energy storage module 40 or the machine tool 20 with the vacuum cleaner 70. The authorisation parameter 442 can for example comprise a manufacturer identifier or the like.

5 The external communication apparatus 100 receives the registration message 440 with a function 416. The function 416 is active for a predetermined time period, for example 500 msec to 1000 msec because in this time the registration procedure must be concluded with the registering energy storage module 40. With a registration confirmation message 445, the external communication apparatus 100 con-
10 firms the registration of the energy storage module 40. The registration confirmation message 445 is sent in a step or transmission operation 417. The registration confirmation message 445 comprises for example the address identifier 446 of the energy storage module 40 as the sender address. Optionally, further information 447 can be contained in the registration confirmation message 445, for example
15 an access key, a password or the like. The information 447 can, however, also for example identify a suction power of the suction unit 75 that is required or to be set or other similar information favourable to the subsequent operation.

The registration of the energy storage module 40 at the external communication apparatus 100 is, however, only a temporary registration which is necessary for a
20 current operation. Accordingly, a temporary identifier 443 is advantageously contained in the registration message 440 such that the external communication apparatus 100 knows so to speak that only a temporary registration or temporary control connection is desired.

At this point, a difference with the so to speak permanent registration for example
25 of the communication module 300 is also clear. In order to register the communication module 300, a longer or more difficult operating action of the operator N is necessary, namely for example a longer actuation of the registration operating element 106 than in the case of a temporary registration. In the case of a standby mode for a permanent control connection or communication relation, the external
30 communication apparatus 100 in the case of the output command 414 gives a signal different with respect to the registration for a temporary control connection to

output to the display device 114, for example for more rapid flashing of the LEDs or flashing of the LEDs at shorter frequency. Lastly, the communication module 300 does not indicate in a registration message comparable with the registration message 440 the temporary identifier 443, but rather a permanent identifier.

- 5 When the wireless communication interface 60 or the energy storage device 40 is successfully registered at the vacuum cleaner 70 or the external communication apparatus 100, both components go into a status 418 "connected". The permanently registered communication module 300 would also adopt this status. It should be added that the function 431 advantageously comprises a time limitation.
- 10 If a registration confirmation message 445 does not arrive within a predetermined or settable time, for example 500 to 1000 msec after switching on the switching element 24 and/or after sending the registration message 440, the registration attempt fails so to speak.

- Proceeding from the status 418 "connected", an authentication procedure and/or
- 15 an encryption procedure is advantageously provided. The subsequently established control connection S1 or S2 should namely advantageously take place in an authenticated and/or encrypted manner.

- For example, the external communication apparatus 100 transmits with an encryption parameter 451. When namely a previous encryption or previous communication
- 20 has already existed between the external communication apparatus 100 and one of the energy storage modules 40A, 40B, the external communication apparatus 100 uses the already existing parameters. For example, the address identifier 446 and assigned thereto the encryption parameter 451 of an already previously existing control connection to the energy storage module 40A, 40B are
- 25 stored in the memory 118 of the external communication apparatus.

- For example, it is mentioned that other address identifiers and assigned encryption parameters can also be stored in the memory 118, for example an address identifier 446C of the wireless communication interface 60C and an encryption parameter 451C for a control connection between the wireless communication interface
- 30 60C of the machine tool 20B and the external communication apparatus 100.

It should be mentioned at this point that the external communication apparatus 100, when encryption parameters for the respective energy storage module 40 are not known, sends, using a message 455, the encryption parameter 451 or a new, different encryption parameter 456 such that an encrypted communication between the components 100, 40 is possible and therefore the status 421 “encrypted connection” is achieved.

Optionally, the external communication apparatus 100, in particular its control device 116, controls the display device 114 (step 423A) such that it signals the available, encrypted connection. For example, the display device 114 then permanently illuminates.

It is also possible that a plurality of address identifiers and/or encryption parameters is stored at an energy storage module. Thus, for example in the case of the energy storage module 40 or the control apparatus 46, provision can be made for it to have stored address data and encryption data of a further vacuum cleaner not represented in the drawing, namely for example an address identifier 441B and an encryption parameter 451B of this further vacuum cleaner. Therefore, the energy storage module 40 can also, if required, so to speak access other vacuum cleaners directly.

Coming back to the function/communication process 400, the further communication takes place for example as follows:

In a function 433 “switch on”, the energy storage module 40 sends in a transmission operation 434 for example the control device 46 for example a control command 460 which contains a switch-on identifier 461. In addition, the control device 46 activates in an activation step 435 the display device 44 to display the established control connection S1 or S2. For example, the lights 445 illuminate blue or in a pattern different to the display of a charge status.

After receiving the control command 460, the external communication apparatus 100 for example actuates the control device 86 such that it switches on the suction unit 75 in a step 422. In addition, the external communication apparatus 100, in

particular its control device 116, controls the display device 114 (step 423) such that it signals the switching-on of the suction unit 75. For example, the display device 114 then permanently illuminates.

When the operator N releases the switching element 24, the current flow via the drive motor 22 for example ends. The control device 46 can detect this, for example using a corresponding current sensor 62. The supply voltage or bus voltage UB1 is in this case also lower or smaller. Furthermore, it is possible that the energy storage module 40 actively sends the data interfaces or bus interfaces 34, 54 a message 753 "motor switched off". One or a plurality of these trigger events, which are triggered by the operating step 403 of the operator N, lead to a function 436 "switch off" of the energy storage module 40. This then sends in a transmission operation 437 a control command 462 to switch off the suction unit 75, preferably after a predetermined stopping time for the suction unit 75, with the message or the control command 462 containing a switch-off identifier 463. In the switch-off identifier 463, for example a stopping time for the vacuum cleaner 70 or the suction unit 75 is indicated.

The request message 750 and the message 753 form received information EM, which the energy storage module 40 receives at the data interface 54, in order to output namely for example the registration message 440 to the wireless communication interface 60 as a function of transmission signals SII.

The response message 445 is for example a received signal ESI, using which the energy storage module 40 outputs the response message 752 to the data interface 54 as transmission information SM.

In a function 427 "switch off", the communication apparatus 100 actuates, directly or actuating the control device 86, the suction unit 75 to switch off and the display device 114 to display the ended actuation. For example, the function 427 gives an actuation command 425 to the suction unit 75 directly or via the control device 86, namely the data interfaces 83 and 108.

When the switching element 24 of the machine tool 20 is actuated again, the energy storage module 40 can send further subsequent control commands 460 and 462 in order to switch on and switch off the suction unit 75. Advantageously, provision is made for the respective control connection between energy storage module
5 and external communication apparatus 100 to end after a predetermined time so that for example the external communication apparatus goes into a status 428 (corresponding to the status 411) and searches for devices authorised to establish a control connection. The energy storage module 40 in contrast goes into a status 439, namely a status "sleep", corresponding to the status 430. When the control
10 connection from the energy storage module 40 to the external communication apparatus 100 or the vacuum cleaner 70 has ended, the function 436 expediently outputs this new operating status to the display device 44, for example by the display device 44 being actuated using an actuation in a deactivation step 438 to signal the ended control connection. The lights 45 then for example no longer illuminate blue, but rather green and signal the charge status of the energy storage device 42.
15

Furthermore, it is possible that the machine tool 20 sends a configuration message 754 via the bus BU to the energy storage module 40. In the configuration message, for example configuration data 755 is indicated to set the vacuum cleaner
20 70, for example a required suction power of the suction unit 75, a typical particle amount in the dust generated by the machine tool 20 etc. The energy storage module 40 preferably provides this data via the wireless communication interface 60 to the external communication apparatus 100 to configure the vacuum cleaner 70, for example as configuration message 465. The external communication apparatus 100 provides the configuration data 755 to the control device 86 to further
25 process, in particular suitably actuate the suction unit 75, e.g. using a transmission operation 437'.

It is preferred for the control device 86 and/or the external communication apparatus 100 to permanently store the configuration data 755 and assign it to the re-
30 spective machine tool 20A and 20B, for example in the memory 88 and/or 118.

Furthermore, it is advantageous for an operator to be able to override the stored configuration so to speak, for example by an actuation of the operating element arrangement 77. Thus, for example a suction power of the suction unit 75 can be set at a switching element 78A.

5 It is possible that suction parameters set directly by an operator at the vacuum cleaner, in particular suction parameters set at the switching element 78A or other operating elements of the operating element arrangement 77, are permanently stored by the control device 86 and/or the external communication apparatus 100 and assigned to the respective machine tool 20A and 20B, for example in the
10 memory 88 and/or 118 when the vacuum cleaner is currently actuated by the respective machine tool, for example one of the machine tools 20A or 20B. In this scenario, it is possible, however not absolutely necessary, for the configuration data 755 or suction parameters to be sent wirelessly by the machine tool 20A or 20B.

15 Establishing a control connection can, however, also take place automatically so to speak when an energy storage module 40 and a machine tool 20 are connected together. This is explained below by way of example of one of the energy storage modules 40. However, it is also possible that for example the wireless communication interface 60C in this manner so to speak automatically establishes a respec-
20 tive control connection to the vacuum cleaner 70 or the external communication apparatus 100 when the energy supply is so to speak started by the energy storage module 40 or is arranged on the device interface 30.

Thus, for example the energy storage module 40 and/or the machine tool 20 can have capacity sensors 66, 36 with which capacities C1 and C2 between the supply
25 contacts 32A, 32B or 52A, 52B can be measured. The capacitive relationships change namely between the lines L1 and L2 thus at the energy-supplying contacts or the energy-supplying lines when a respective energy storage module 40 is fastened to a machine tool 20. The sensors 36, 66 are connected with the control devices 26, 46 or communicate therewith. Thus, for example the control device 46,
30 when the sensor 66 identifies that the machine tool 20 is connected, i.e. an operating status is achieved, can automatically send the registration message 440.

In order to identify a separation status and/or an operating status between an energy storage module 40 and a machine tool 20 and/or a vacuum cleaner, at least one verification message in particular provided exclusively to verify the operating status or separation status can be provided to a data interface, for example the bus interface BU. For example, a type of ping message can be provided for this purpose. The processor 27 and/or a processor 27A of the machine tool 20 or of the charging device 220 provided especially for the mentioned purpose can in particular cyclically send a verification message CK, using which the energy storage module 40 identifies for example that it is connected to the machine tool 20 or the charging device 220 or that there is no connection to such a device. It is possible that in order to receive the verification message CK the processor 47 or a processor 47A provided especially for this message is present at the energy storage module 40. The processor 47 and/or 47A can send as the response to the verification message CK for example a response message RP.

In another manner, it can also be sensorily detected whether an energy storage module 40 and a machine tool 20 are in a separation status or another operating status connected to one another, when namely the device interfaces 30, 50 are connected to one another.

Thus, for example a sensor 58 can sense an actuation of the actuation element 57 of the fixing device 55. When an operator pushes the actuation element 57, consequently thus wishes to trigger the fixing of the fixing device 55, this will be assessed as a transition from the operating status to the separation status. The energy storage module 40, in particular the wireless communication interface 60 can in this case for example automatically end the control connection S1 or S2. To this end, the wireless communication interface 60 for example sends a corresponding separation command or a separation message. It is particularly preferred when, through actuation of the actuation element 57, also the vacuum cleaner 70 can also be switched off because the components 20 and 40 are separated from one another. For example, the control device 46 sends the control command 462 when the actuation element 57 is actuated, which can be detected by the sensor 58.

However, it is also possible that for example one or a plurality of motion sensors are provided, namely for example a motion sensor 59 at the energy storage module 40 and a motion sensor 59B at the machine tool 20. When the motion sensors 59, 59B signal the same movements, the control devices 46, 26 can communicate
5 this to one another and as a result identify that the energy storage device 40 and the machine tool 20 are in the operating status, i.e. in the status fastened to one another.

Furthermore, it is possible that for example an optical sensor 68 or another proximity sensor detects when the device interface 30 is fastened to the device inter-
10 face 50. The optical sensor or proximity sensor 68 is for example marked on the energy storage module 40A according to Figure 5, but could readily also be provided on the device interface 30 of the machine tool 20 (see Figure 4).

Like the proximity sensors or optical sensors 68 (ultrasonic sensors, magnetic sensors or the like can also for example be provided), an electric switch 68, in particu-
15 lar a push button or press button is also actuated when the plug positive-locking contours 51 and 31 are engaged with one another, i.e. when the device interfaces 30, 50 are mechanically connected to one another. The electric switch 69 can also therefore distinguish the operating status from the separation status of the device
20 interfaces 30, 50 and lead to the wireless communication interface 60C or the energy storage module 40 sending the registration message 440.

It is also possible that the energy storage module 40 receives in the context of the received information EM at least one status information item, in particular error in-
25 formation and/or switching position of a switch, of the electric device and/or at least one identification information item, for example a serial number of the electric device. Thus, for example the energy storage module 40 can receive error infor-
30 mation as status information 29C and identification information 29D for example a unique identifier or a serial number of the machine tool 20, from the machine tool 20. In this case, it is possible that the machine tool 20 sends this received information EM spontaneously via the data interface 54, i.e. without previous request
by the energy storage module 40 at the machine tool 20 or that the energy storage module 40 requests this received information EM at the machine tool 20. The error

information can for example represent overheating or electric overloading of the machine tool 20. The identification information 29D can also comprise a type identifier, so that for example the type of machine tool 20, in particular screwing device, sawing machine or the like can be identified using the identification information 29D.

The aforementioned received information EM is for example not security-related or to be kept secret. In particular, it is advantageous for the energy storage module 40 to send, in particular encrypted, this received information EM in the context of a broadcast communication or advertising communication cyclically or periodically and/or at the transition from the separation status to the operating status, i.e. in the case of connection to the machine tool 20. Of course, encrypted communication can also take place when for example encryption parameters are already exchanged between the energy storage module 40 and the configuration apparatus 500 or another receiving device. In all aforementioned scenarios, for example the configuration apparatus 500 can receive the identification information 29D and/or the status information 29C from the energy storage module 40.

The vacuum cleaner 70 can, as explained, have one or a plurality of communication modules 300. The arrangement with a plurality of configuration modules 300A, 300B and 300C is optional, i.e. only one of these communication modules could for example be provided or even none of them. The vacuum cleaner 70 would still function.

The communication modules 300A can be used using their communication interfaces 311 to maintain or establish a control connection. Thus, for example a control connection S6 can be established by the hand-held machine tool 20B or the energy storage module 40B to the vacuum cleaner 70 or the external communication apparatus 100, which is established and/or maintained at least partially by the communication module 300B and 300C.

Thus, for example the wireless communication interface 60C of the machine tool 20A or the wireless communication interface 60 of the energy storage module 40B can communicate on a section S61 firstly with the communication module 300, for

example in order to send the control command 460 and/or 462, i.e. to switch on and switch off the suction unit 75. On a communication section or connection section S6.2, the communication module 300 communicates this information or this control command to the communication module 300B which in turn provides the received control command or the received information on a connection section
5 S63 to the external communication apparatus 100 or the vacuum cleaner 70. Since the communication modules 300B and 300C are arranged only at a short distance to the system components 20B/40B, on the one hand, and, on the other hand, to the vacuum cleaner 70 or the communication device 100, the connection
10 sections S61 and S63 are short. Accordingly, the transmission power of the external communication apparatus 100 and of the wireless communication interface 60/60C can be particularly low.

In particular on a short transmission path between the respective communication module 300B and the wireless communication interface 60, 60C or the communication module 300C and the external communication device 100 not only is the
15 transmission power particularly low, but the security aspect is also particularly favourable. For example, the receiving ranges of the communication modules 300B and 300C can be designed short such that interrupting information of a third party or an interrupting control command is not even received and provided by the communication modules 300B and 330C.
20

Of course, the communication modules 300B and 300C can also provide information sent by the vacuum cleaner 70 to the energy storage module 40B or the machine tool 20B, i.e. they can operate unidirectionally either from the vacuum cleaner to the machine tool or vice versa from the machine tool to the vacuum
25 cleaner or even bidirectionally. The gateway function is expediently bidirectional. Thus, the vacuum cleaner 70 can for example communicate via the control connection S6, which is in this case a reporting connection, for example a fill level of the dirt collection chamber 73 such that the machine tool 20B possibly adjusts its operation when dust discharge is no longer possible.

The communication modules 300A and 300B can also readily in this manner implement a gateway function in relation to the machine tool 22A and the vacuum cleaner 70.

5 It is not absolutely necessary that, in order to implement the gateway function, two communication modules are provided, of which one is arranged closer to the vacuum cleaner and the other closer to the machine tool or its energy storage module. For example, it is possible that a communication module 300, for example the communication module 300A serves as a gateway between the external communication apparatus 100 and the energy storage module 40A.

10 The communication modules can also assist with establishing communication relations and in particular control connections. Furthermore, a communication module 300 can also be authorised in the following manner for the controlling or communicating wireless connection with the external communication apparatus 100.

15 For example, the external communication apparatus 100 has a communication interface 109 according to a second standard, which differs from the communication interface 110. For example, the first standard of the communication interface 110 is a Bluetooth WLAN or the similar other standard, while the second standard of the communication interface 109 is configured for near-field communication, for example is an RFID communication interface or a NFC communication interface.

20 Further components of the system 10 also expediently have further communication interfaces of this second standard. Thus, for example in the case of the communication module 300, such a communication interface 318 is present. The energy storage module 40 can also have such a communication interface of the second standard, namely a communication interface 67. Lastly, the communication in-
25 terface of the second standard can also be provided directly on or in the vacuum housing 71, in particular as a communication interface 84.

The communication interfaces of the second standard, for example of the near-field communication standard serve to store and/or transmit communication parameters which are required for the control connections or reporting connection

S1, S2. Control connections S3 and S4 of the communication modules 300A and 300B, with which they actuate the vacuum cleaner 70, for example switch on and switch off the suction unit 75, can in this manner so to speak be authorised or parameterised. Lastly, the gateway function, i.e. the control connection S6 can be set
5 using the communication interfaces of the second standard.

Some variants are preset as follows:

For example, in the case of the communication interface 84 and/or communication interface 109, the address identifier 441 of the vacuum cleaner 70 and the encryption parameter 451 are stored as communication parameters 85, which are re-
10 quired to establish a control connection with the vacuum cleaner 70 or the external communication apparatus 100. When one of the communication modules 300A, 300B or 300C enters with its communication interface 318 in the transmission range of the communication interface 109 and/or the communication interface 84, it can read the communication parameters 85. The reverse approach is also possible that for example the communication parameters of the communication module
15 300 are stored therein and can be read by one or both of the communication interfaces 109, 84.

However, the wireless communication interfaces 60 or 60C can also be configured in this way. Thus, for example the communication interface 37 of the machine tool
20 20 can read the communication parameters 85 when it is in proximity to the communication interface 84. A respective energy storage module 40 can also read, using its communication interface 67, the communication parameters 85 from the communication interface 84 and/or 109 or receive said communication parameters therefrom.

In order to establish a control connection of the communication module 300 and/or the energy storage module 40B to the external communication apparatus 100, a communication interface 909 can also be implemented in the shape of for example an NFC transmitter or RFID transmitter. The communication interface 909 is for example arranged on the longitudinal end region 17 of the suction hose 15. For
25
30 example, the communication interface 909 comprises communication parameters

for the first standard which can be read by a corresponding reading communication interface 910 of the vacuum cleaner 70 or 870. The communication interface 109 can for example be an RFID tag, NFC tag or the like. In the case of the communication interface 909, further parameters 911 can also be stored, for example
5 a hose geometry of the suction hose 15, in particular its length and/or diameter, etc., and these further parameters 911 can be read by the communication interface 910.

Furthermore, it is possible that one or a plurality of communication interfaces of the second standard so to speak serve as transfer communication parameters. For
10 example, the communication module 300B can directly read the communication parameters 85 on the vacuum housing 71, namely on the communication interface 84 and/or 109 and then transmit these to the machine tool 20B and/or the energy storage module 40B. The communication module 300B is in this case so to speak an intermediate memory for the communication parameters 85.

15 A further possibility to switch the external communication apparatus 100 or the vacuum cleaner 70 to the standby mode to establish a control connection, is implemented for example by an acceleration sensor or motion sensor 312. The acceleration sensor 312 sends acceleration signals to the control device 336 which identifies, using the movement signals or reporting signals of the acceleration sensor 312, a typical plug movement or installation movement of the suction hose 15
20 on the machine tool 20A, 20B. For example, the control device 336 identifies, using the acceleration sensor 312, a typical insert movement, which represents a linear movement and/or rotational movement, which has a predetermined length, namely the insert path when plugging the suction hose 15 on one of the suction
25 outlets 39.

Furthermore, it is possible that using a further motion sensor, which is on board the energy storage module or the machine tool, a movement pattern is identified. Thus, for example the motion sensor 59 of the energy storage module 40 can detect a movement pattern and transmit this via the wireless communication inter-
30 face 60 to the communication module 300. The communication module 300 compares the movement pattern of the motion sensor 59 with a movement pattern of

the motion sensor or acceleration sensor 312. If both movement patterns are identical, this is an indication that the suction hose 15 is fastened or will be fastened to the machine tool 20, for example when the movement patterns are directed in the same manner, but opposingly. Using this information, the communication module
5 300 can for example establish the control connection S1 or S2. The identification of the movement pattern of the acceleration sensor 312 and/or 59 can thus for example trigger the establishment of a respective control connection S1 or S2 and/or the pairing function, in particular sending the registration message 360.

For the configuration and/or control, a device located outside of the system machine tool, energy storage module, suction hose and vacuum cleaner can also be
10 used, namely for example a configuration apparatus 500. The configuration apparatus 500 is for example a computer, in particular a smartphone, a smartwatch, a tablet computer or the like. The configuration apparatus 500 has a housing 501 which is mobile and independent of the suction hose 15 and vacuum cleaner 70.
15 The housing 501 is also not part of one of the machine tool 20 or the energy storage module 40. However, it would be conceivable that for example a module holder 96 is present on the vacuum cleaner 70 into which the configuration apparatus 500 suitable as a remote control can also be inserted. The configuration apparatus 500 has a display device 502 and an input means 503 to output information for the operator N and to input commands. The input means 503 can be
20 part of the display device 502, for example in the manner of a touchpad.

The configuration device 500 has a control device 506 with a processor 507 and a memory 508. One or a plurality of program modules 509, whose program code can be executed by the processor 507, is stored in the memory 508. Furthermore,
25 a configuration module 510 is stored in the memory 508, which may be suitable to configure the control connections S1 - S4. The configuration module 510 has program code which can be executed by the processor 507. The configuration apparatus 500 can directly actuate the vacuum cleaner 70 in the manner of the communication module 300. To this end, for example a communication interface 511 is
30 provided, in particular a Bluetooth interface, WLAN interface or the like, which can communicate directly with the external communication apparatus 100. For example, an input at the input means 503 in the manner of an actuation of one of the

registration operating elements 316 or 106 is possible. The configuration apparatus 500 then executes for example program code of the configuration module 510 to switch the external communication apparatus 100 to the standby mode in which the energy storage modules 40 or the machine tool 20 can be authorised to
5 establish the control connection.

Furthermore, the configuration apparatus 500 expediently has a configuration interface 512 with the second standard, for example an RFID interface. Therefore, the configuration apparatus 500 can for example read and/or send the configuration parameters 85.

10 It should be added at this point that of course the machine tools 20 with their communication interfaces 37 of the second standard and/or the energy storage modules 40 with their communication interfaces 67 can be brought directly in proximity to the vacuum housing 71 and/or the external communication apparatus 100 to read the communication parameters 85 and/or to send their communication pa-
15 rameters.

It should be added at this point that of course the machine tools 20 with their communication interfaces 37 of the second standard and/or the energy storage modules 40 with their communication interfaces 67 can be brought directly in proximity to the vacuum housing 71 and/or the external communication apparatus 100 to
20 read the communication parameters 85 and/or to send their communication parameters. Therefore, the machine tools 20 and the energy storage modules 40, just as the vacuum cleaner 70, also form configurations modules with in each case one communication interface of the first and the second communication standard.

Furthermore, the configuration apparatus 500 is for example suitable for loading
25 software or at least one program module, configuration data or the like in one of the energy storage modules 40 and/or one of the machine tools 20. The wireless communication interfaces 60, 60C communicate in this case preferably directly with the communication interface 511 of the configuration apparatus 500. In this way, for example a program module 49 can be transmitted to an energy storage

module 40 or a program module 29 to a machine tool 20. Furthermore, for example configuration data 29A, for example operational parameters and/or machine settings (maximum speed, maximum power, use duration limits or the like), for the machine tool 20 can be transmitted. A program module 29 can be transmitted directly for example via the communication interface 60 to the machine tool 20 or indirectly via an energy storage module 40, i.e. its wireless communication interface 60 and via the data interfaces 34, 54 communicating with one another from the energy storage module 40 to the machine tool 20, in particular its control device 26.

Of course, a gateway function of a machine tool to the energy storage module is also possible, i.e. that for example the wireless communication interface 60C receives a program module 49 for an energy storage module 40 and transmits it via the data interfaces 34, 54 to the energy storage module 40.

In the reverse direction, data of the machine tool 20 can be received for example by the energy storage module 40 and transmitted to the configuration apparatus 500, for example protocol data 29B, in particular data of an error memory, a log file or the like. For example errors occurring during the operation of the machine tool 20, in particular temperature exceedances or the like can be contained in the error memory. The log file contains for example data about the use of the machine tool 20. Using the energy storage module 40, which operates so to speak as a gateway, use duration, error situations or the like can be read from the machine tool 20 using the configuration apparatus 500. The machine tool 20 does not need its own radio interface or other wireless interface.

Controlling information can be sent on the control connections S1 - S6, for example switching commands for the suction unit 75, dust class, speed setting, power consumption, contact pressure and particular concentration or dust concentration of a respective machine tool 20. Furthermore, configuration of the vacuum cleaner 70 is possible, i.e. that via one or a plurality of control connections S1 - S6 configuration data or reporting data are transmitted from the machine tool 20 and/or the energy storage module 40 to the vacuum cleaner 70, for example stopping time after switching off the suction unit, required power of the suction unit or the like.

The configuration apparatus 500 could be registered according to the function and communication process 400 temporarily at the external communication apparatus 100. However, permanent registration is preferred in the manner of the communication modules 300. The registration operating element 106 for example must be
5 pressed for a long time to authorise or register the configuration apparatus 500 at the vacuum cleaner 70 or the external communication apparatus 100. In this way, it is ensured that only an authorised and legitimate device is registered.

A prioritisation and security concept is presented below:

The components of the system 10 permanently registered at the vacuum cleaner
10 70 for control are provided for priority actuation of the vacuum cleaner 70, e.g. the mains-connected machine tool 20C and the configuration modules 300 and the configuration apparatus 500. When a switch-on signal or switch-off signal for the suction unit 75 comes from one of these components, this is handled by the vacuum cleaner 70, in particular its control device 86, as a priority over a correspond-
15 ing control command of the machine tools 20A and 20C equipped with energy storage module 40.

Furthermore, operation at one of the operating elements of the operating element arrangement 77 is a priority. Thus, for example when the switching element 78 is actuated, every other control connection is subordinate.

20 In the case of the remote controls, i.e. for example the communication modules 300 or the configuration apparatus 500, a one-to-one relationship to the vacuum cleaner 70 is provided. Therefore, a remote control cannot erroneously actuate another vacuum cleaner. Similarly, it is always advantageous when always only one machine tool is authorised with energy storage module at the vacuum cleaner 70
25 and can actuate it. As soon as further or another machine tool is authorised, the authorisation of the previously authorised machine is erased. Therefore, always only one of the control connections S1 or S2 is possible in the case of the specific exemplary embodiment.

Instead of the current detection of the outlet 79 or in addition thereto, a pressurised air detection could also be provided. Therefore, for example a device operating with pressurised air, for example a grinding machine or polishing machine can be connected to the vacuum cleaner 70. If it is switched on or switched off, the suction unit 75 is running or will be switched off again. A corresponding pressurised air sensor is in this case present on the connection device. The connection device can be a flow device, i.e. that pressurised air is, on the one hand, fed into the vacuum cleaner 70 and, on the other hand, is so to speak tapped from the pressurised air machine not represented in the drawing. If a pressurised air machine or mains machine (machine tool 20C) is switched on and is connected to the vacuum cleaner 70, this has the highest priority. The communication modules 300 and the configuration apparatus 500, like the switching element 78, have a medium priority.

The battery machines or machine tools 20A, 20C provided with energy storage modules have the lowest priority.

It may be advantageous for cancelling an authorisation or ending a control connection S1 - S6 for this to be triggered by ending the respective energy supply. Thus, when for example an energy storage module 40A, 40B is separated from the machine tool 20A, 20B, the control connections S1 or S2 are automatically ended. Also, when the energy supply 310 of the configuration module 300 is removed, the authorisation at the vacuum cleaner 70 is automatically cancelled. In this case, it is advantageous for the energy storage module 40 or the machine tool 20 to send a switching command to switch off the suction unit 75 in the case of such a separation.

A remote control, for example the communication module 300 or the configuration apparatus 500 is expediently registered with a new identity at the external communication apparatus 100 or the wireless interface 60, when the energy supply has ended, for example the energy supply 310 has been removed. Therefore, for example a new encryption can be configured. When a new identity is available, i.e. for example a new address identifier is available, both communication partners are

ready to negotiate new encryption parameters. When wireless communication interfaces 60, 60C concurring with one another wish to establish a control connection with the vacuum cleaner 70 or the external communication apparatus 100, the in each case first registered wireless communication interface 60 is for example
5 accepted. Thus, when for example the switching element 24 of the machine tool 20A is pressed before the switching element 24 of the machine tool 20C during the standby mode of the external communication apparatus 100, the control connection S1 is established as a priority.

Furthermore, it is advantageous that in the case of concurring machines the one
10 that can establish the control connection is the one closer to the receiving external communication apparatus 100. In the exemplary embodiment according to Figure 1, this could be for example the energy storage module 40A which wishes to establish the control connection S1. For example, the wireless communication interface 60 can write into the registration message 440 signal strength information 448
15 with the signal strength with which it sends the registration message 440.

Using one of the sensors 111 measuring the signal strength, the external communication apparatus 100 can measure the strength of the signal with which the registration message 440 is received, and compare it with the signal strength information 448. The control device 86 can then determine therefrom a value for a distance
20 between the components 40A and 100.

The wireless communication interface 60C or the energy storage module 40B are, however, still remote from the external communication apparatus 100, thus are treated subordinately.

It is also possible that no signal strength information 448 is contained in the registration message 440. In this situation, the sensor 111 can compare the signal
25 strength of the registration message 440 for example with a threshold value.

Furthermore, it is possible that the sensor 111 for example directly compares the signal strengths of the registration messages 440 of the energy storage modules 40A and 40B with one another and responds exclusively or earlier, i.e. with a

shorter response time to the registration message 440 which has a greater signal strength.

Prioritisation of communication partners arranged closer to the external communication apparatus 100 can for example be provided such that the external communication apparatus 100 sets different response times. This is indicated in Figure 5 16. For example, a response time $AS(t)$ is greater or smaller as a function of a signal strength S which the sensor 111 measures. Thus, for example, the external communication apparatus 100 can respond more quickly to the registration message 440 of the energy storage module 40A, which has a greater signal strength, 10 and send a response message, for example the registration confirmation message 445 than to a corresponding registration message 440 of the energy storage module 40B.

It is preferred when the communication parameters stored in the memory 118 of the external communication apparatus 100, for example the address identifiers 15 446 and 446C and the assigned encryption parameters 451, 451C are erased after a predetermined time and/or after complete separation of the energy supply. Even in the case of the mobile device, namely for example the energy storage module 40A, 40B, it is advantageous for the communication parameters to be 20 erased from the memory 48 after a predetermined time and/or after separation of an energy supply.

Furthermore, it is possible that an authorisation of a mobile device, namely a machine tool 20 or an energy storage module 40 at which the external communication apparatus is erased, i.e. that the control connections $S1$, $S2$ are considered 25 erased when the respective machine tool 20, its energy storage module 40 has switched on the vacuum cleaner 70, but another function, for example the switching element 78 or the mains machine tool 20C has switched off the vacuum cleaner again.

Furthermore, it is expedient when the communication parameters at a mobile device, which can establish a control connection, are reset in relation to a charging

operation, when for example the energy storage module 40 is connected to the charging device 220, the parameters 441, 451 are erased.

By corresponding actuation of the registration operating element 316 of the communication module 300, for example a correspondingly long pressing, a wireless communication connection can also be established between the communication
5 module 300 and the configuration apparatus 500, e.g. for a software update or the like.

A system represented in Figure 15 comprises a machine tool 20D which is a mains-connected machine tool or a machine tool operable with an energy storage
10 module 40D. The energy storage module 40D and a further energy storage module 840, which is suitable for operating a vacuum cleaner 870, functionally correspond to the energy storage module 40B. The structure is also discernible from the drawing itself.

The machine tool 20D is for example a grinding device for grinding a workpiece W.
15 Using the suction hose 15 and the connection piece 17, the machine tool 20D can be connected to the vacuum cleaner 870, namely to a suction inlet 872.

The vacuum cleaner 870 is a stackable vacuum cleaner arranged in a stacking box. For example, it has a box-shaped vacuum housing 871 which can be stacked on, under or in a stack, which also has for example containers to store hand-held
20 tools, machine tools, e.g. the machine tool 20D and the like. No further detail is given on the connection components to form such a stack. A plurality of coupling elements 801, for example latches, locks or the like can be discerned for example at the front side of the vacuum housing 871 to couple with a container stacked on top and/or below.

25 A suction unit 875 in the manner of suction unit 75 is arranged in the interior of the vacuum housing 871, which is closable with a lid. A filter 874 and a dirt collection chamber 873 are also located there, in particular in a container removable from the vacuum housing 871. A device interface 830 is provided on the outside or in

the interior of the vacuum housing 871, which is compatible with the device interface 50 of the energy storage module 840 such that the vacuum cleaner 870 is operable with the energy storage module 840.

The energy storage module 840 can now communicate directly with the energy storage module 40D. Thus, the machine tool 20D can actuate via its energy storage module 40D the energy storage module 840D which in turn actuates the vacuum cleaner 870 to switch on and/or switch off the suction unit 875. In this case, the communication takes place via the already explained data interfaces 34, 54 between the respective first and second system components, namely the machine tool 20D and the energy storage module 40D and the vacuum cleaner 870 and the energy storage module 840. It should be mentioned at this point that the registration using for example the registration message 440 is also possible in the case of the system according to Figure 15. However, it is also possible that the energy storage modules 40D and 840 already represent a communication pair, which is authorised for mutual communication. Therefore, operator interventions are not necessary in order to establish the control connection between the vacuum cleaner and the machine tool.

It is possible that the machine tool 20 and/or the charging device 220 periodically or cyclically switches on the supply voltage UB1 or supply voltage UB2 so that the energy storage module 40 identifies that it is connected to the machine tool 20 or the charging device 220, in particular in the case of the connection to the machine tool 20, when it is switched off, in order to maintain a corresponding control connection to for example the vacuum cleaner 60 or in the case where the connection to the charging device 220 does not have to establish such a control connection.

A preferred design provides for an energy storage module 40 and/or configuration apparatus 500 and/or at least one communication module 300, when there is already an authorisation at the vacuum cleaner 60 or the external communication apparatus 100, to firstly again receive a connection to this so to speak stored vacuum cleaner. An authorisation is in this case already available. In this case, the registration message 440 with the broadcast transmission identifier 44x is so to

speaking omitted, i.e. a registration message, which is directed to a plurality of essentially ready-to-receive vacuum cleaners, not only the vacuum cleaner 70. Advantageously, a registration message 440 in this case expediently contains an address identifier of the vacuum cleaner 70.

1. Electric apparatus as a first or second system component (11, 12) for a system comprising as a first system component (11) a machine tool (20) and as a second system component (12) an electric energy storage module (40) for providing electric energy for the first system component (11), wherein
5 the system components (11, 12) have matching apparatus interfaces for releasable mutual attachment and for transmitting electric energy from the energy storage module (40) to the machine tool (20), wherein the electric apparatus has a communication interface for a wireless control connection (S1, S2) to or from a vacuum cleaner (70, 870) to activate the vacuum
10 cleaner (70, 870), which is provided for extracting dust generated by the machine tool (20) and is a separate vacuum cleaner (70, 870), and wherein the apparatus interfaces are electrically and/or mechanically disconnected from each other in a disconnection state and electrically and/or mechanically connected to each other in an operating state, wherein the electric apparatus is, at a transition from the disconnection state to the operating
15 state, equipped for sending or receiving at least one log-in message (440) for building up the control connection (S1, S2) and/or, at a transition from the operating state to the disconnection state, equipped for terminating the control connection (S1, S2) and/or for sending a disabling signal for a suction unit (75) of the vacuum cleaner (70, 870), characterised in that the apparatus interface comprises a data interface, in particular a bus interface, and in that the electric apparatus is equipped for the identification of the operating state and/or the disconnection state using a data traffic via the data
20 interface.
- 25 2. Electric apparatus according to claim 1, characterised in that it has at least one sensor for detecting the operating state and/or the disconnection state of the apparatus interface.
3. Electric apparatus according to claim 2, characterised in that the least one sensor comprises or is represented by a sensor for the detection of at least
30 one electric variable, in particular an electric capacitance, of the respectively other system component (11, 12), and/or in that the least one sensor

comprises or is represented by a distance sensor for the detection of a mutual distance of the system components (11, 12) and/or a motion sensor for the detection of a movement of the system components (11, 12) relative to each other and/or an optical sensor for the detection of the respectively
5 other system component (11, 12).

4. Electric apparatus according to claim 2 or 3, characterised in that the least one sensor comprises an electric switch, in particular a pressure switch or pushbutton, which can be actuated by attaching the system components (11, 12) to each other.

10 5. Electric apparatus according to any of the preceding claims, characterised in that it has a mechanical actuating element, in particular a pushbutton, for actuating a fixing device, in particular a locking device, for fixing the system components (11, 12) to each other, wherein it is advantageously provided that it has at least one sensor for the detection of an actuation state of the
15 actuating element, wherein the electric apparatus rates an actuation of the actuating element towards a release of the fixing device as a transition from the operating state to the disconnection state.

6. Electric apparatus according to any of the preceding claims, characterised in that the one apparatus interface has plug-in positive-locking contours
20 (51) for affixing to mating plug-in positive-locking contours of the other apparatus interface along a plug-in axis and electric contacts for contacting mating contacts of the other apparatus interface for an electric connection of the system components (11, 12), which come into contact with each other at a plugging-together of the plug-in positive-locking contours (51) and
25 the mating plug-in positive-locking contours.

7. Electric apparatus according to any of the preceding claims, characterised in that the energy storage module (40) has a module housing (41) and an energy store accommodated in the module housing (41), in particular an assembly with at least one rechargeable electric storage cell, for the provision

of electric energy for the energy supply of supply contacts (52) provided on the machine tool (20) or the vacuum cleaner (70, 870).

8. Electric apparatus according to any of the preceding claims, characterised in that it comprises at least one checking message, in particular exclusively provided for checking the operating state or the disconnection state for the identification of the operating state and/or the disconnection state.
9. Electric apparatus according to any of the preceding claims, characterised in that it is equipped for an authentication when building up the control connection (S1, S2).
10. Electric apparatus according to any of the preceding claims, characterised in that the communication interface is equipped for an encrypted communication via the control connection (S1, S2).
11. Electric apparatus according to any of the preceding claims, characterised in that it forms the second system component (12) and thus an electric energy storage module (40) and is equipped for the reception of at least one reception information (EM) from the first system component (11) in connection with a transition from the disconnection state to the operating state, and in that it is equipped for the in particular encrypted sending of the at least one reception information (EM) as broadcast information or advertising information via the wireless communication interface (60).
12. System (10) comprising an electric apparatus according to any of the preceding claims and the respectively other system component (11, 12), so that a system combination of energy storage module (40) and machine tool (20) is formed, wherein it is advantageously provided that it comprises the machine tool (20) activated via the control connection (S1, S2) or the vacuum cleaner (70, 870) activated via the control connection (S1, S2).
13. Method for a system with an electric apparatus comprising as a first system component (11) a machine tool (20) and as a second system component

(12) an electric energy storage module (40) for providing electric energy for the first system component (11), wherein the system component (11, 12) have matching apparatus interfaces for releasable mutual attachment and for transmitting electric energy from the energy storage module (40) to the machine tool (20), wherein the electric apparatus has a communication interface for a wireless control connection (S1, S2) to or from a vacuum cleaner (70, 870) to activate the vacuum cleaner (70, 870), which is provided for extracting dust generated by the machine tool (20) and is a separate vacuum cleaner (70, 870), and wherein the apparatus interfaces are electrically and/or mechanically disconnected from each other in a disconnection state and electrically and/or mechanically connected to each other in an operating state, wherein the method comprises:

- sending or receiving, at a transition from the disconnection state to the operating state, at least one log-in message (440) for building up the control connection (S1, S2) by the electric apparatus and/or,
- at a transition from the operating state to the disconnection state, by terminating the control connection (S1, S2) and/or sending a disabling signal for a suction unit (75) of the vacuum cleaner (70, 870) by the electric apparatus, wherein the apparatus interface comprises a data interface, in particular a bus interface, and wherein the electric apparatus identifies the operating state and/or the disconnection state using a data traffic via the data interface.

Patentkrav

5 1. Elektrisk indretning som en første eller anden systemkomponent (11, 12) for et system, der som en første systemkomponent (11) omfatter en værktøjsma-
skine (20) og som en anden systemkomponent (12) et elektrisk energilagring-
modul (40) til at levere elektrisk energi til den første systemkomponent (11),
hvor systemkomponenterne (11, 12) har til hinanden passende indretnings-
grænseflader til udløselig fastgørelse på hinanden og til overførsel af elektrisk
10 energi fra energilagermodulet (40) til værktøjsmaskinen (20), hvor den elektri-
ske indretning har en kommunikationsgrænseflade for en trådløs styreforbin-
delse (S1, S2) til eller fra en støvsuger (70, 870) til styring af støvsugeren (70,
870), der er tilvejebragt til udsugning af støv, som frembringes af værktøjsma-
skinen (20), og en støvsuger (70, 870), som er separat fra systemkomponen-
terne (11, 12), og hvor indretningsgrænsefladerne er elektrisk og/eller meka-
15 nisk frakoblet hinanden i en frakoblingstilstand og er elektrisk og/eller meka-
nisk forbundet med hinanden i en driftstilstand, den elektriske indretning ved
en overgang fra frakoblingstilstanden til driftstilstanden er indrettet til at sende
eller modtage mindst en tilmeldingsmeddelelse (440) til opbygning af styrefor-
bindelsen (S1, S2) og/eller ved en overgang fra driftstilstanden til frakobling-
20 tilstanden er indrettet til at afbryde styreforbindelsen (S1, S2) og/eller til at
sende et afbrydelsestegn for et sugeaggregat (75) af støvsugeren (70, 870),
kendetegnet ved, at indretningsgrænsefladerne omfatter en datagrænse-
flade, især en busgrænseflade, og at den elektriske indretning er udformet til
at genkende driftstilstanden og/eller frakoblingstilstanden på grundlag af data-
25 trafikken via datagrænsefladen.

30 2. Elektrisk indretning ifølge krav 1, **kendetegnet ved, at** den har mindst en
sensor til registrering af indretningsgrænsefladens driftstilstand og/eller frakob-
lingstilstand.

3. Elektrisk indretning ifølge krav 2, **kendetegnet ved, at** den mindst ene sen-
sor omfatter eller er dannet af en sensor til registrering af mindst en elektrisk

størrelse, især en elektrisk kapacitet, af den respektivt anden systemkomponent (11, 12), og/eller at den mindst ene sensor omfatter eller er dannet af en afstandssensor til registrering af en afstand mellem systemkomponenterne (11, 12) i forhold til hinanden og/eller en bevægelsessensor til registrering af en relativbevægelse af systemkomponenterne (11, 12) i forhold til hinanden og/eller en optisk sensor til registrering af den respektivt anden systemkomponent (11, 12).

5

4. Elektrisk indretning ifølge krav 2 eller 3, **kendetegnet ved, at** den mindst ene sensor omfatter en elektrisk kontakt, som kan aktiveres ved, at systemkomponenterne (11, 12) fastgøres på hinanden, især en trykkontakt eller en tastekontakt.

10

5. Elektrisk indretning ifølge et af de foregående krav, **kendetegnet ved, at** den har et mekanisk aktiveringselement, især en trykkontakt, til aktivering af en fikseringsindretning, især en låseanordning, til fiksering af systemkomponenterne (11, 12) på hinanden, hvor det fordelagtigt er tilvejebragt, at den har mindst en sensor til registrering af en aktiveringstilstand af aktiveringselementet, hvor den elektriske indretning evaluerer en aktivering af aktiveringselementet i retning mod en løsning af fikseringsindretningen som en overgang fra driftstilstanden til frakoblingstilstanden.

15

20

6. Elektrisk indretning ifølge et af de foregående krav, **kendetegnet ved, at** den ene indretningsgrænseflade har stik-formsluttende konturer (51) til påsætning på stik-mod-formsluttende konturer af den anden indretningsgrænseflade langs en stikakse samt elektriske kontakter til kontakt med elektriske modkontakter af den anden indretningsgrænseflade til en elektrisk forbindelse af systemkomponenterne (11, 12), som kommer i elektrisk kontakt med hinanden ved en stikmontering af de stik-formsluttende konturer (51) og de stik-mod-formsluttende konturer.

25

30

7. Elektrisk indretning ifølge et af de foregående krav, **kendetegnet ved, at** energilagermodulet (40) har et modulhus (41) og et energilager, som er op-

taget i modulhuset (41), især en anordning med mindst en genopladelig elektrisk lagercelle (43), for at tilvejebringe elektrisk energi til energiforsyning af forsyningskontakterne (52), som er tilvejebragt til værktøjsmaskinen (20) eller støvsugeren (70, 870).

5

8. Elektrisk indretning ifølge et af de foregående krav, **kendetegnet ved, at** den til detektering af driftstilstanden og/eller frakoblingstilstanden omfatter mindst en kontrolmeddelelse, som især udelukkende er tilvejebragt til kontrol af driftstilstanden eller frakoblingstilstanden.

10

9. Elektrisk indretning ifølge et af de foregående krav, **kendetegnet ved, at** den ved opbygningen af styreforbindelsen (S1, S2) er indrettet til en autentificering.

15

10. Elektrisk indretning ifølge et af de foregående krav, **kendetegnet ved, at** kommunikationsgrænsefladen er indrettet til en krypteret kommunikation via styreforbindelsen (S1, S2).

20

11. Elektrisk indretning ifølge et af de foregående krav, **kendetegnet ved, at** den danner den anden systemkomponent (12) og således et elektrisk energilagermodul (40) og er indrettet til modtagelse af mindst en modtagelsesinformation (EM) fra den første systemkomponent (11) i forbindelse med en overgang fra frakoblingstilstanden til driftstilstanden, og at den især er indrettet til ukrypteret forsendelse af den mindst ene modtagelsesinformation (EM) via en trådløs kommunikationsgrænseflade (60), hvor det fordelagtigt er tilvejebragt, at den er indrettet til at sende den mindst ene modtagelsesinformation (EM) som broadcast-information eller advertising-information via den trådløse kommunikationsgrænseflade (60).

25

30

12. System (10) omfattende en elektrisk indretning ifølge et af de foregående krav og den respektive anden systemkomponent (11, 12), således at en systemkombination er dannet af et energilagermodul (40) og en værktøjsmaskine (20) eller støvsuger (70, 870), hvor det fordelagtigt er tilvejebragt, at den omfatter værktøjsmaskinen (20), som styres via styreforbindelsen (S1, S2),

eller støvsugeren (70, 870), som styres via styreforbindelsen (S1, S2).

- 5 **13.** Fremgangsmåde til et system med en elektrisk indretning, der som en første systemkomponent (11) omfatter en værktøjsmaskine (20) og som en anden systemkomponent (12) et elektrisk energilagermodul (40) til tilvejebringelse af elektrisk energi for den første systemkomponent (11), hvor systemkomponenterne (11, 12) har til hinanden passende indretningsgrænseflader til udløselig fastgørelse på hinanden og til overførsel af elektrisk energi fra energilagermodulet (40) til værktøjsmaskinen (20), hvor den elektriske indretning har en kommunikationsgrænseflade for en trådløs styreforbindelse (S1, S2) til eller fra en støvsuger (70, 870) til styring af støvsugeren (70, 870), som er tilvejebragt til udsugning af støv, der frembringes af værktøjsmaskinen (20), og er separat fra systemkomponenterne (11, 12), og hvor indretningsgrænsefladerne er elektrisk og/eller mekanisk frakoblet hinanden i en afbrydelsestilstand og er elektrisk og/eller mekanisk forbundet med hinanden i en driftstilstand, og hvor fremgangsmåden omfatter:
- 10 - der sendes eller modtages mindst en tilmeldingsmeddelelse (440) til opbygning af styreforbindelsen (S1, S2) via den elektriske indretning ved en overgang fra afbrydelsestilstanden til driftstilstanden, og/eller
- 20 - ved en overgang fra driftstilstanden til afbrydelsestilstanden afbrydes styreforbindelsen (S1, S2), og/eller der sendes et afbrydelsessignal for et sugeaggregat (75) af støvsugeren (70, 870) via den elektriske indretning, hvor indretningsgrænsefladerne omfatter en datagrænseflade, især en busgrænseflade, og at den elektriske indretning genkender driftstilstanden og/eller frakoblingstilstanden på grundlag af datatrafikken via datagrænsefladen.
- 25

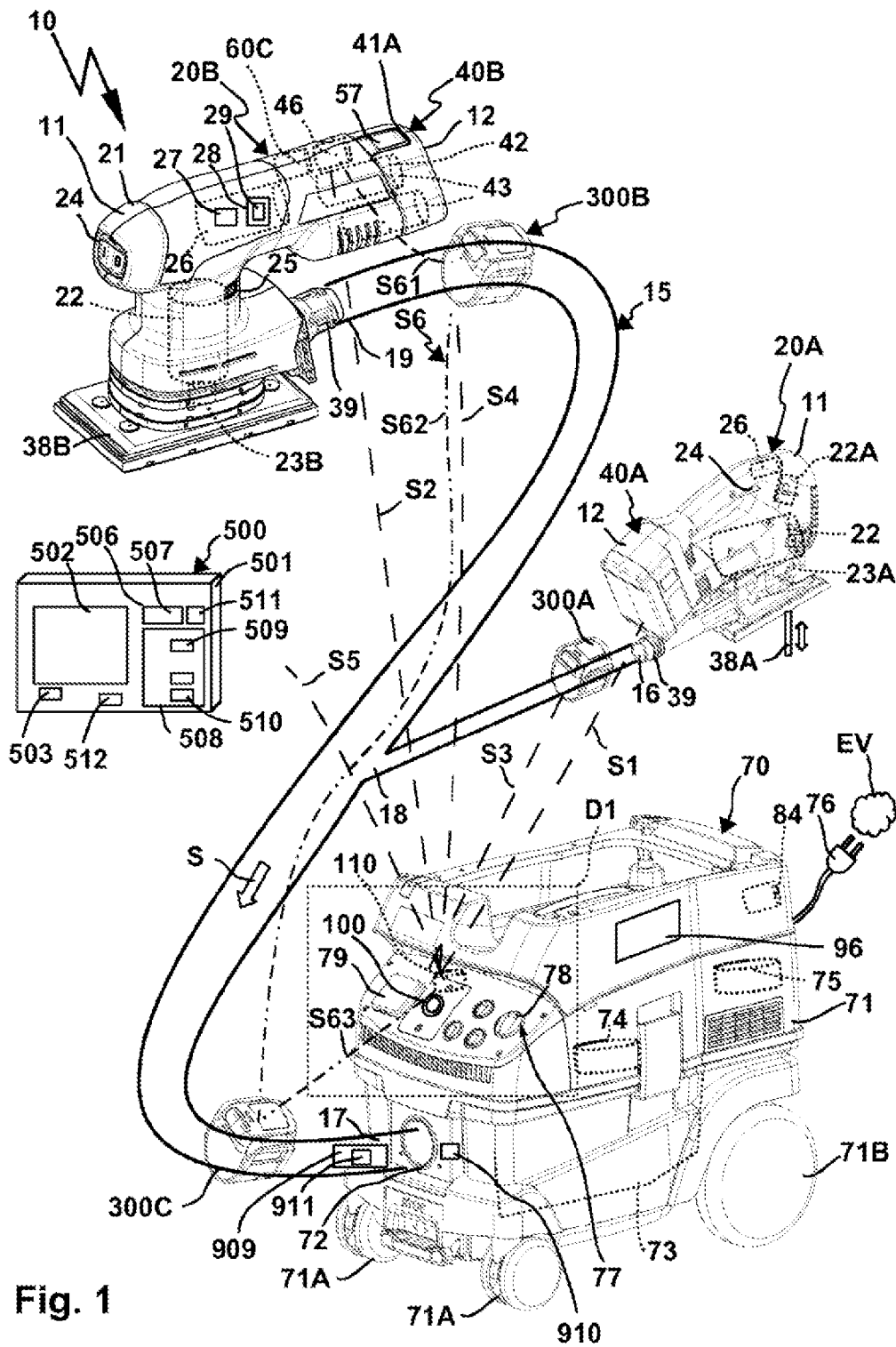

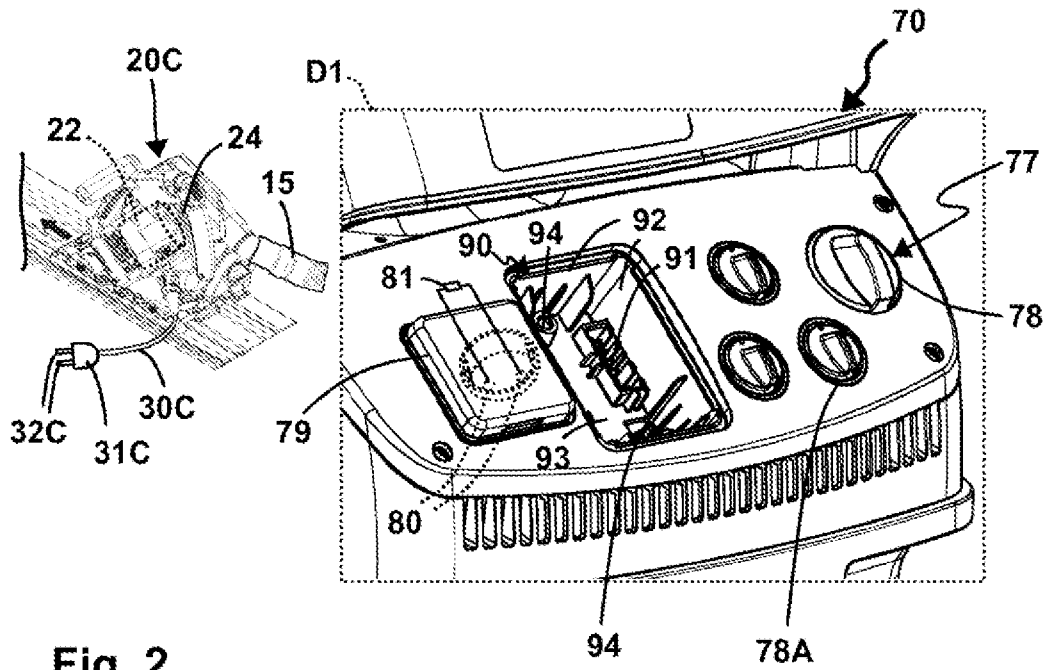

Fig. 2

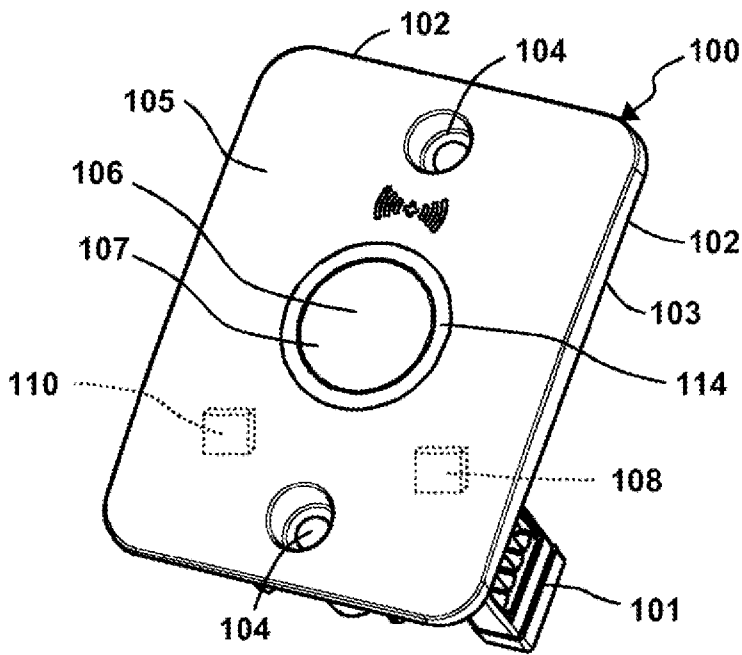

Fig. 3

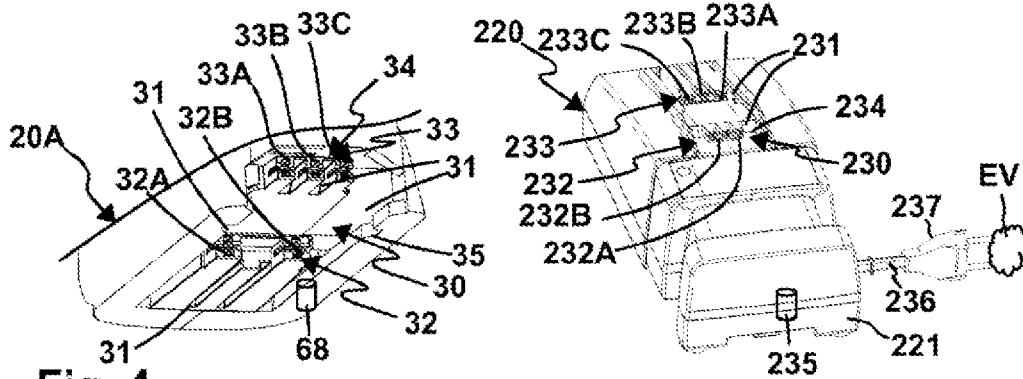

Fig. 4

Fig. 7

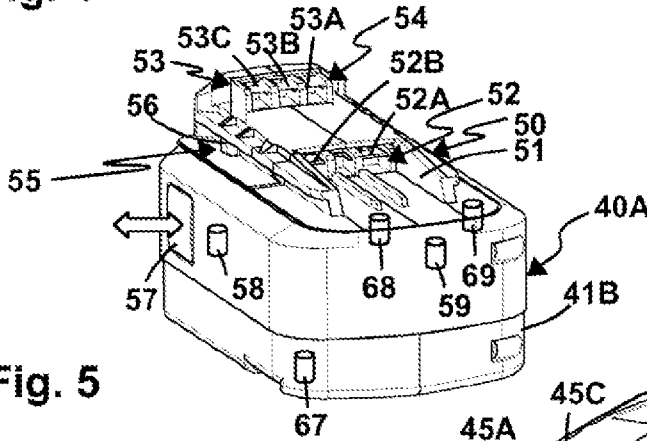

Fig. 5

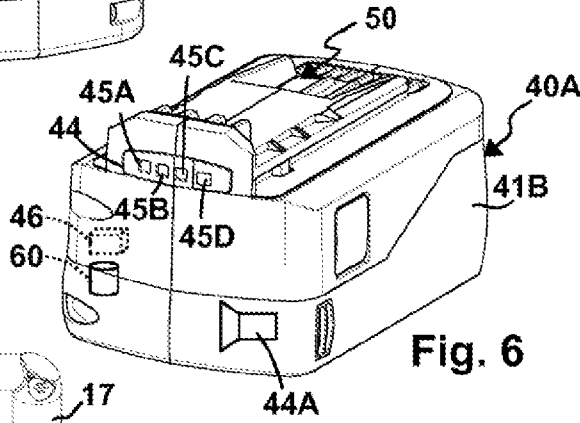

Fig. 6

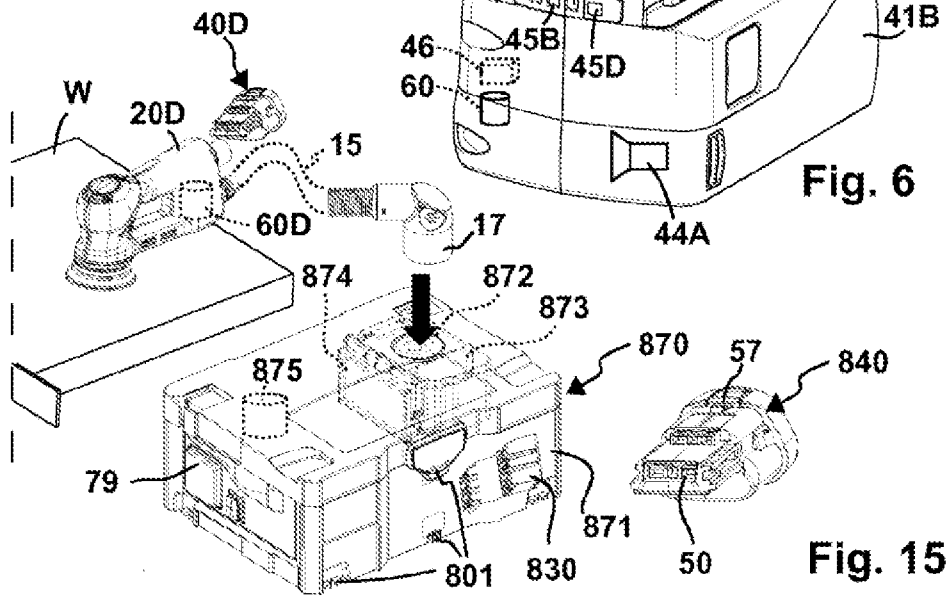

Fig. 15

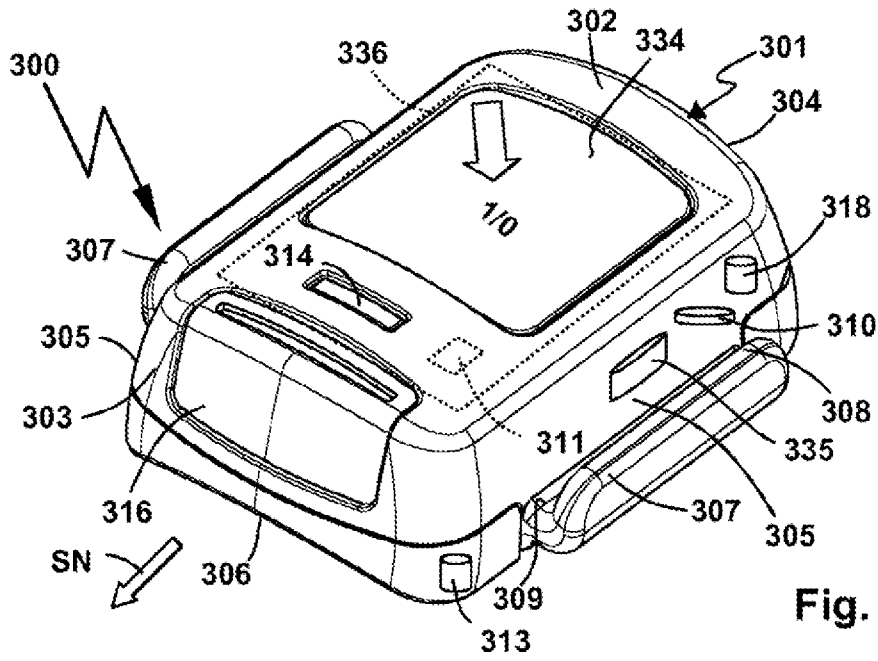

Fig. 8

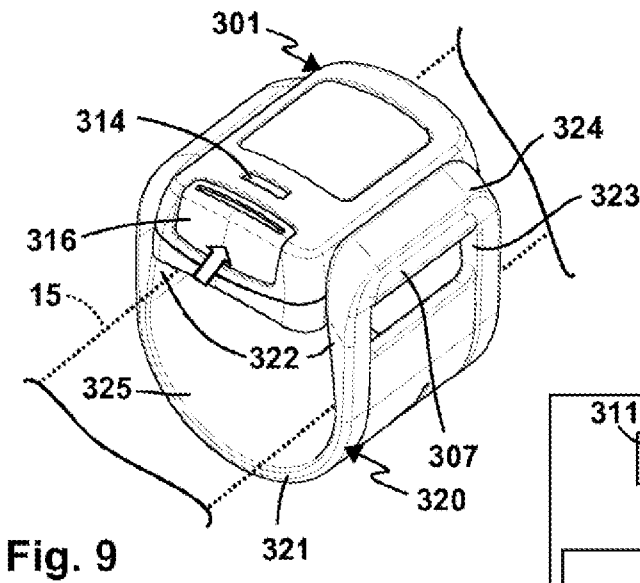

Fig. 9

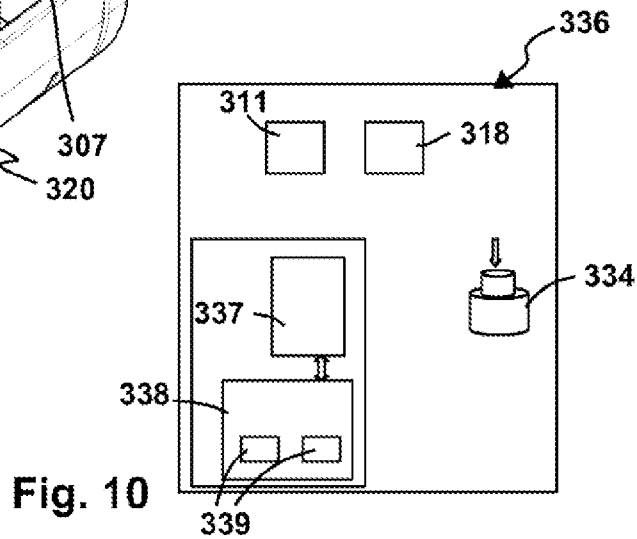

Fig. 10

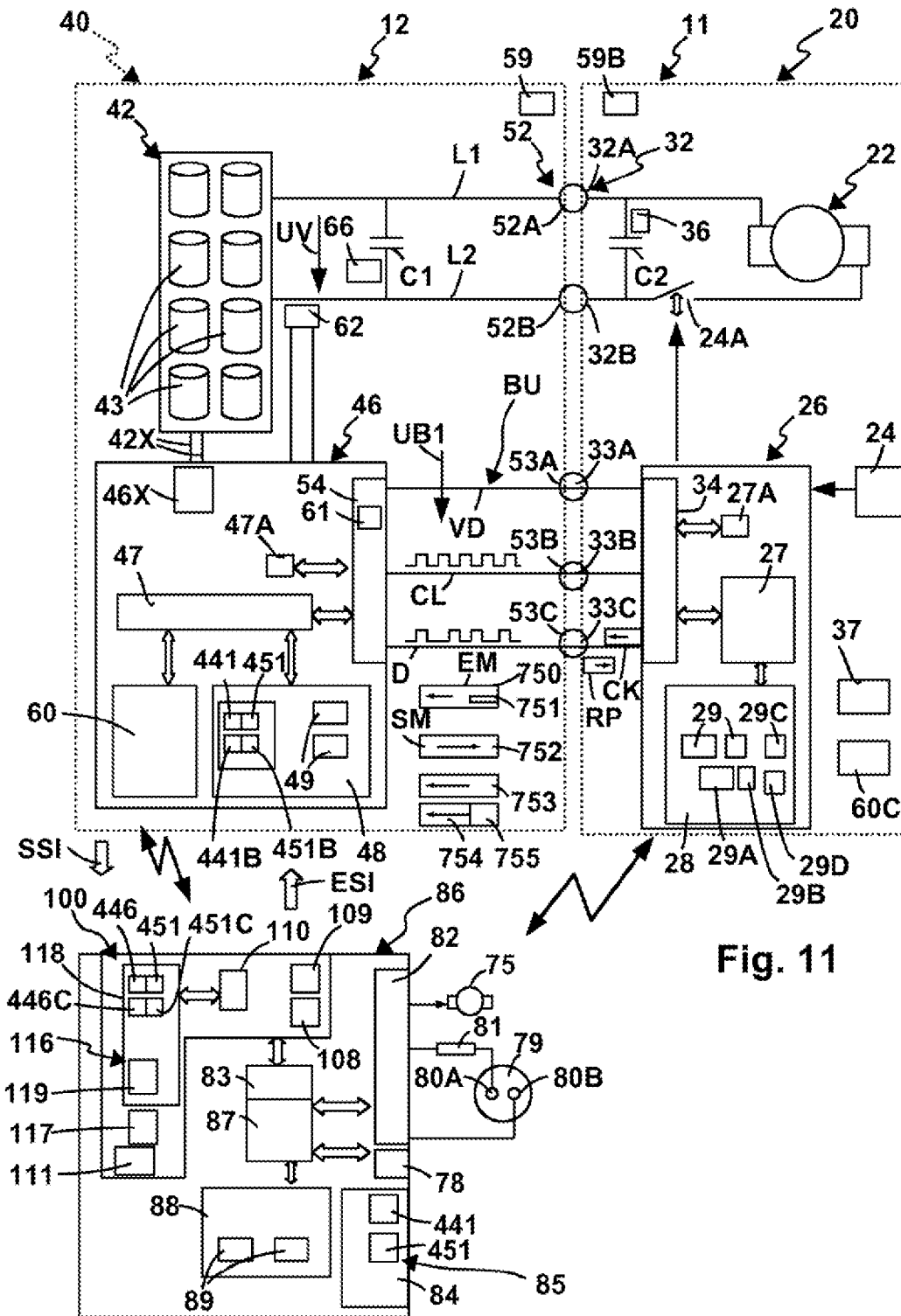

Fig. 11

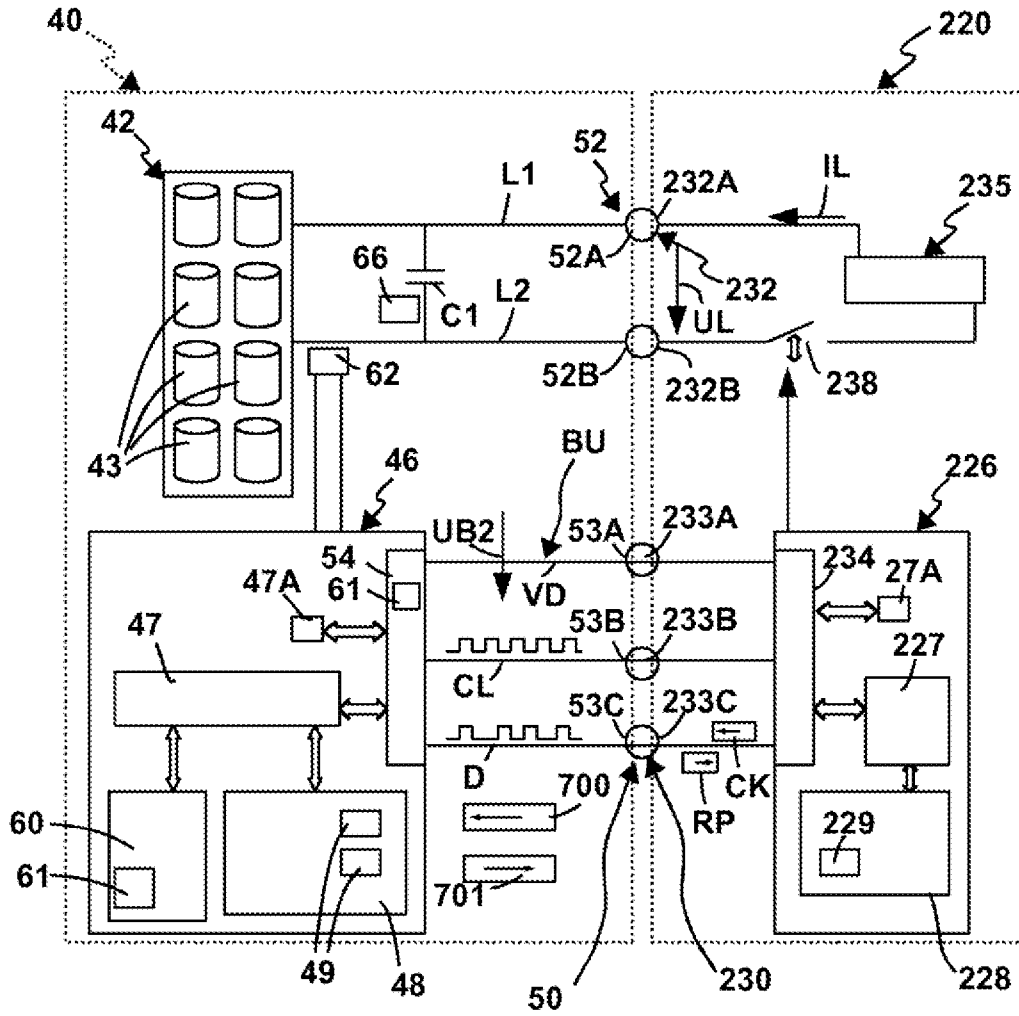

Fig. 12

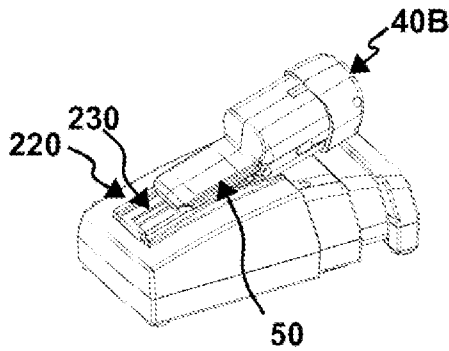

Fig. 13

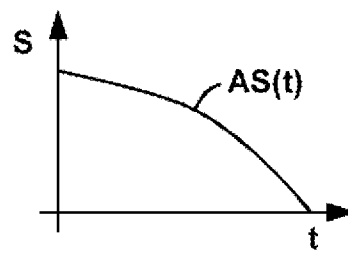

Fig. 16

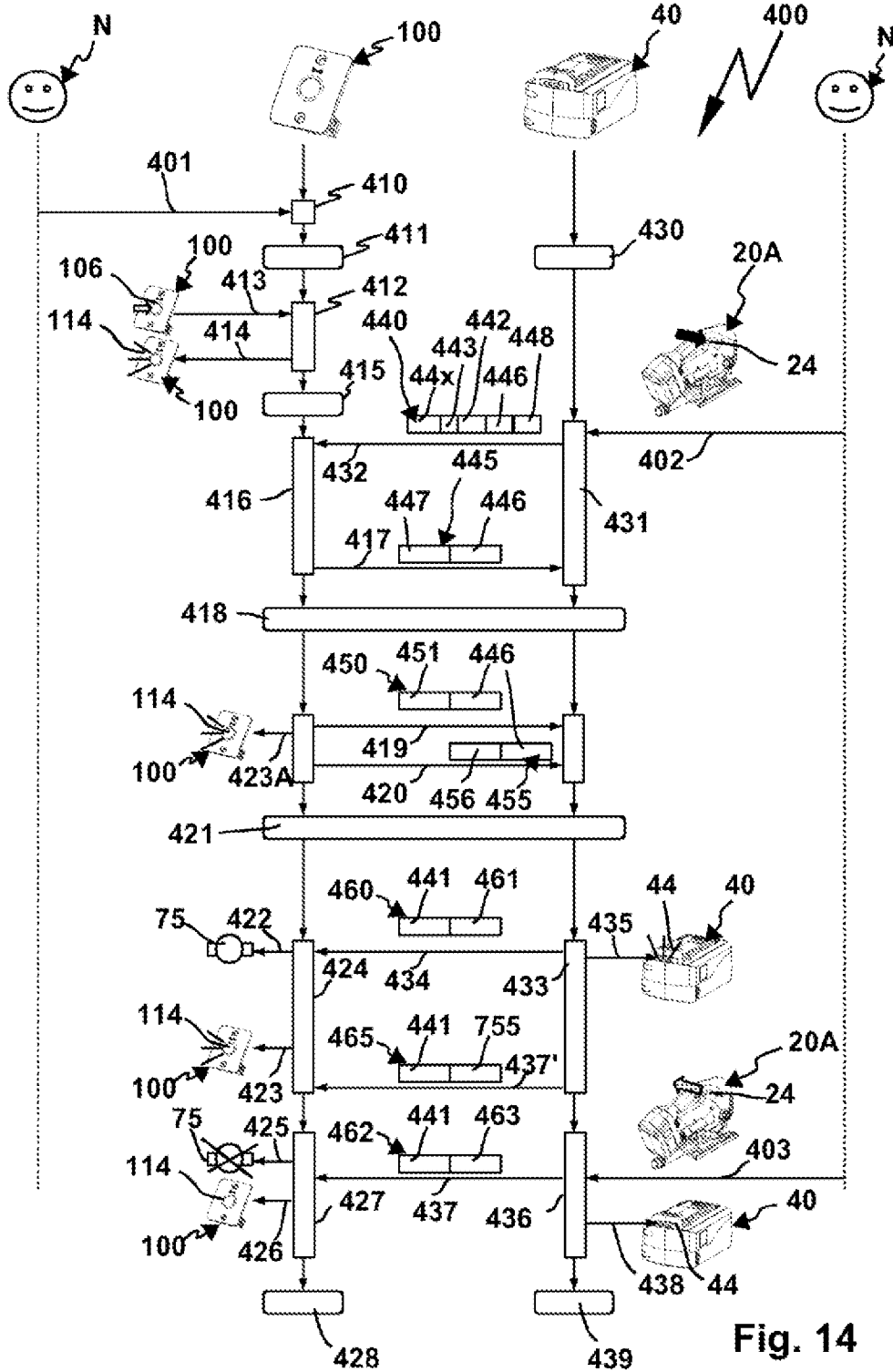

Fig. 14