

Dec. 2, 1952

A. HALL

2,620,005

INSERT FOR HANDBAGS

Filed Feb. 25, 1950

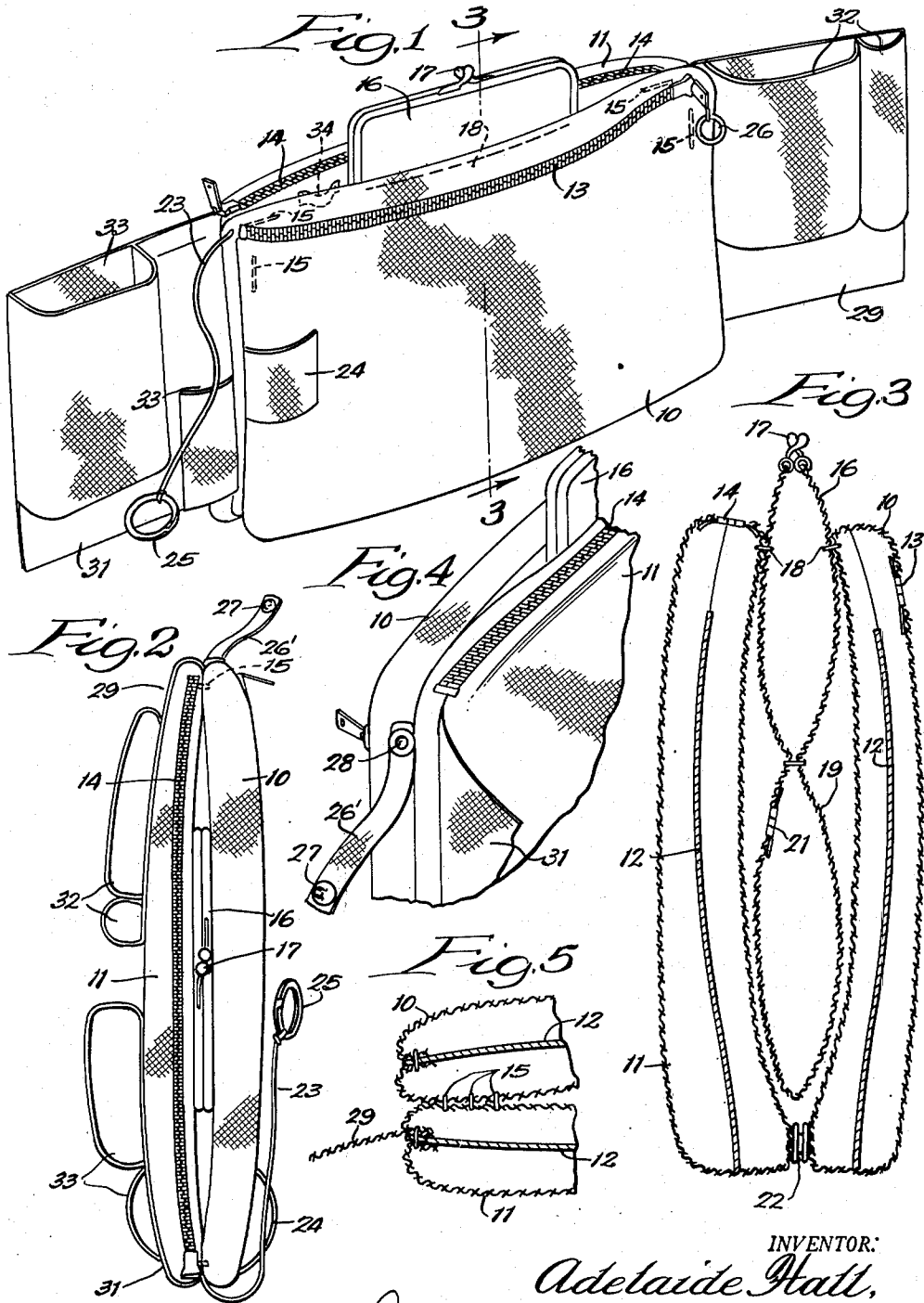

INVENTOR:

Adelaide Hall,

BY Dawson, Orms, Broth and Spangenberg,  
ATTORNEYS.

# UNITED STATES PATENT OFFICE

2,620,005

## INSERT FOR HANDBAGS

Adelaide Hall, Los Angeles, Calif.

Application February 25, 1950, Serial No. 146,313

1 Claim. (Cl. 150—35)

1

This invention relates to inserts for hand bags, and more particularly to an insert for a lady's hand bag, to receive and carry the several articles normally carried in a hand bag.

Ladies' hand bags are usually made with possibly one or two small pockets in the sides to receive special articles, and with the major part of the bag consisting of a single large pocket. In such bags it is extremely difficult to find articles, and it is also troublesome to remove all of the articles from one bag when a different bag is to be carried.

It is one of the objects of the present invention to provide an insert in which all of the articles can be carried and which can easily be transferred from one hand bag to another.

Another object is to provide an insert having an individual device or pocket for each article which can easily be located by feel so that articles carried in the bag can easily be found.

A further object is to provide an insert in which a coin purse is carried at the upper part of the structure for easy and rapid location by feel.

Still another object is to provide an insert having end extensions thereon which can be extended out from the main portion of the insert for use in relatively long hand bags and which can be folded over the main body of the insert for use in relatively short bags.

A still further object is to provide an insert on which keys can easily be supported for ready access.

The above, and other objects and advantages of the invention will be more readily apparent from the following description when read in connection with the accompanying drawing in which:

Fig. 1 is a perspective view of an insert embodying the invention;

Fig. 2 is a top view;

Fig. 3 is a transverse section on the line 3—3 of Fig. 1;

Fig. 4 is a partial perspective view of Fig. 1 and of the insert; and

Fig. 5 is a horizontal section.

The insert as shown comprises a number of pocket units 10 and 11, which may be the same or different sizes and shapes and which are adapted to lie in side by side relation. The pocket units may be of cloth, plastic or other flexible or rigid material, and are preferably in the form of relatively large pockets having openings near their tops. Dividers 12 are preferably inserted in the pocket units to divide them into

2

compartments, and if desired, additional dividers or inserts may be provided to form any preferred number of pockets to receive special articles. It is contemplated that one of the pockets may be employed to carry bills, papers and the like, so that it may contain a single central divider separating it into two compartments. The other pocket may contain miscellaneous articles such as cosmetics, and may be further sub-divided if desired.

The pocket units are preferably formed with openings at slightly different locations therein so that they can easily be distinguished by feel. As shown, the opening in the unit 10 is on the outer side thereof, spaced slightly below its top and is closed by a slide fastener 13. The opening in the pocket unit 11 is in the central part of its top and is closed by a slide fastener 14. With this construction the units can easily be distinguished by feel without the necessity of looking into the hand bag to determine which is which.

The pocket units are connected together in side by side relationship, and in the construction shown the connection is limited to the upper part thereof. This connection can be in the form of either permanent or detachable fastenings, and as shown comprise the stitching 15 securing together the adjacent walls of the units near the top and ends thereof. In the central portion of the units a coin purse unit is mounted between them and comprises a coin purse 16, which is arranged so that it projects above the side units. The coin purse 16 may be in the form of a conventional coin purse having snap fastenings 17 at its top, and is secured by fastenings 18 to the adjacent walls of the side units, as best seen in Fig. 3. With this construction the coin purse projects above the side units and can easily be located and opened merely by feel.

According to one feature of the invention a second purse or pocket unit 19 may be secured below the coin purse 16 to be wholly enclosed between the side units. The pocket or purse unit 19 may be closed by a slide fastener 21 in its side near the top thereof and access to it may be obtained by separating the lower parts of the side units. For normal use the lower edges of the side units are detachably connected as by snap fasteners 22, which can be opened for access to the pocket 19.

For convenience in carrying and finding articles such as keys, fastenings are preferably provided at the ends of the insert. As shown, an elastic band 23 may be attached to one end of the

3

insert and may carry a key holding ring 25 at its other end. It is contemplated that a key such as a house key may be attached to the ring 25 so that it can be used without detaching it from the insert to eliminate any possibility of loss. 5 The key may be carried in a pocket 24 on the outside of the unit 10.

At the other end of the insert a holding device is provided to hold other keys such as car keys which must be completely removed for use. As 10 shown, this device comprises a spring ring 26 which can be snapped open for insertion or removal of keys and snapped closed to hold the keys. With this construction articles such as car 15 keys can be detachably supported in a position where they can easily be located by feel. Additionally a flexible strap 26' may be secured to one end of the purse body and may carry snap fasteners 27 and 28 at its ends so that it can be 20 looped around articles to be carried, such as handkerchiefs, to hold them conveniently.

For the carrying of additional articles flexible flaps 29 and 31 can be secured to the ends of the insert to project outwardly therefrom, as shown 25 in Fig. 1. The flap 29 as illustrated, is formed with pockets 32 which may be designed to receive articles such as compacts, lipsticks, perfume and the like, so that the articles are supported in a position where they can easily be found. The 30 flaps 31 may be provided with pockets 33 designed to receive articles such as cigarettes, lighters and the like, so that they will be held properly in position for ready access.

When the insert is used with an elongated type of hand bag the flaps may be extended, as 35 shown in Fig. 1. For shorter bags the flaps may be folded over, as illustrated in Fig. 2, so that the overall length of the insert will not exceed the length of the bag.

Provisions may also be made for carrying the 40 other types of articles including special pockets or special holding devices. As shown, for example one or more loops 34 may be formed on the inner side of one of the side units to hold pens, pencils or the like in upright, readily ac- 45 cessible position.

With the insert formed as shown it is self supporting and can stand upright on the relatively

4

flat bottoms of the side units. The insert can easily be transferred from one conventional handbag to another or could, if desired, be provided with a covering to be used in place of a conventional handbag.

It will be apparent that the insert of the present invention is susceptible of a substantial variation in the arrangement and number of pockets and devices provided to receive different articles, as may be desired. It is, therefore, not intended that the exact arrangement illustrated shall be taken as a definition of the scope of the invention, reference being had for this purpose to the appended claim.

What is claimed is:

An insert for a handbag adapted to be removably received in a conventional handbag comprising a side unit providing an article receiving pocket opening near its top, a coin purse unit attached to the side unit adjacent the top thereof, the coin purse unit providing an upper coin purse section opening at the top and a lower section secured to and supported by the upper section lying adjacent the bottom of the side unit and opening below the coin purse section.

ADELAIDE HALL.

#### REFERENCES CITED

The following references are of record in the file of this patent:

#### UNITED STATES PATENTS

Number	Name	Date
476,278	Lauferty .....	June 7, 1892
587,251	Wilentshik .....	July 27, 1897
1,463,729	Stember .....	July 31, 1923
1,711,349	Howard .....	Apr. 30, 1929
1,999,669	Smith .....	Apr. 30, 1935
2,022,162	Speik et al. ....	Nov. 26, 1935
2,274,718	Lyndes et al. ....	Mar. 3, 1942
2,414,615	Slotkin .....	Jan. 21, 1947
2,446,009	Hyman .....	July 27, 1948
2,464,312	Holden .....	Mar. 15, 1949
2,477,388	Moore .....	July 26, 1949

#### FOREIGN PATENTS

Number	Country	Date
220,883	Great Britain .....	Aug. 28, 1924