



(51) International Patent Classification:

*B03C 3/12* (2006.01)      *H01T 19/04* (2006.01)  
*B03C 3/019* (2006.01)    *H01T 23/00* (2006.01)  
*B03C 3/41* (2006.01)      *F24F 3/16* (2006.01)  
*B03C 3/47* (2006.01)

(21) International Application Number:

PCT/SE2020/050672

(22) International Filing Date:

26 June 2020 (26.06.2020)

(25) Filing Language:

English

(26) Publication Language:

English

(30) Priority Data:

1950823-3                  28 June 2019 (28.06.2019)                  SE

(71) Applicant: **CABINAIR SWEDEN AB** [SE/SE]; Karlavägen 108, 115 26 Stockholm (SE).

(72) Inventors: **WETTRE, Lars**; Reimersholmagatan 79, 117 40 Stockholm (SE). **NILEVI, Lena**; Tuppstugevägen 19, 136 75 Vendelsö (SE). **HELIN, Emil**; Renstiernas gata 16, 116 28 Stockholm (SE). **FODOR, Attila**; Soltorpsvägen 40, 147 32 Tumba (SE).

(74) Agent: **ZACCO SWEDEN AB**; P.O. Box 5581, Valhallavägen 117N, 114 85 Stockholm (SE).

(81) Designated States (unless otherwise indicated, for every kind of national protection available): AE, AG, AL, AM, AO, AT, AU, AZ, BA, BB, BG, BH, BN, BR, BW, BY, BZ, CA, CH, CL, CN, CO, CR, CU, CZ, DE, DJ, DK, DM, DO, DZ, EC, EE, EG, ES, FI, GB, GD, GE, GH, GM, GT, HN, HR, HU, ID, IL, IN, IR, IS, JO, JP, KE, KG, KH, KN, KP, KR, KW, KZ, LA, LC, LK, LR, LS, LU, LY, MA, MD, ME, MG, MK, MN, MW, MX, MY, MZ, NA, NG, NI, NO, NZ, OM, PA, PE, PG, PH, PL, PT, QA, RO, RS, RU, RW, SA, SC, SD, SE, SG, SK, SL, ST, SV, SY, TH, TJ, TM, TN, TR, TT, TZ, UA, UG, US, UZ, VC, VN, WS, ZA, ZM, ZW.

(84) Designated States (unless otherwise indicated, for every kind of regional protection available): ARIPO (BW, GH, GM, KE, LR, LS, MW, MZ, NA, RW, SD, SL, ST, SZ, TZ, UG, ZM, ZW), Eurasian (AM, AZ, BY, KG, KZ, RU, TJ, TM), European (AL, AT, BE, BG, CH, CY, CZ, DE, DK, EE, ES, FI, FR, GB, GR, HR, HU, IE, IS, IT, LT, LU, LV, MC, MK, MT, NL, NO, PL, PT, RO, RS, SE, SI, SK, SM, TR), OAPI (BF, BJ, CF, CG, CI, CM, GA, GN, GQ, GW, KM, ML, MR, NE, SN, TD, TG).

Published:

— with international search report (Art. 21(3))

(54) Title: AIR PURIFICATION DEVICE

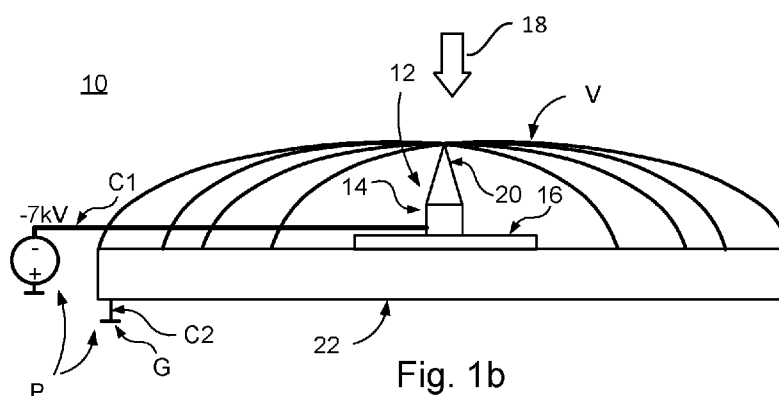

Fig. 1b

(57) Abstract: An air purification device for separating airborne particles from a flow of air is disclosed. The air purification device comprises an emitter electrode, and a filter medium arranged to attract at least a subset of the airborne particles. The filter medium comprises a conductive material. Furthermore, the emitter electrode and the filter medium comprising the conductive material are so arranged as to produce an ionizing volume for charging airborne particles present in the flow of air.



## AIR PURIFICATION DEVICE

## TECHNICAL FIELD

The present disclosure relates to the field of air purification. More particularly the present disclosure relates to an air purification device for separating airborne particles from a flow of  
5 air.

## BACKGROUND

Within many different technical fields, like for example different types of vehicles or buildings air filtration systems are used to ensure the desired air quality within the cabin or building or other closed space.

10 Ionizing filtering systems are frequently used since they provide efficient cleaning of airborne particles. The ionizing filtering system comprises an ionizer (or ionizing unit) that is configured to produce an ionizing volume for electrically charging particles in the air such that the particles adhere to a filter medium arranged downstream the air flow path.

Ions can be produced in several ways but one frequently used arrangement comprises an  
15 emitter electrode and a collector electrode, for example a corona tip surrounded by a collector electrode which could be connected to ground, such that ions are produced in a volume surrounding the emitter electrode, i.e. the corona tip, when a high voltage is applied over the emitter electrode and the collector electrode. The volume in which ions are produced is referred to as ionizing volume and the emitter and collector electrodes are preferably arranged such that  
20 the ionizing volume spans the flow path. When particles pass through the ionizing volume at least a portion of the particles are charged. The charged particles then adhere to the filter medium downstream the air flow path.

When providing ionizing filtering systems in vehicles or in buildings, there are several parameters to be taken into account, such as a need for a sufficient size of a ionizing volume,  
25 i.e. a volume where airborne particles are charged by means of an ion field, that the space for different systems and components may be limited or otherwise restricted in shape, that the effect of the electromagnetic emissions from an ionizing filtering system may affect other

components, and that the possibility to adapt the further equipment and arrangements is limited, that adding further arrangement in a flow of air will affect the flow of air, etc. Hence, there is consequently a need for an ionizing arrangement that provides a suitable trade-off between different limiting parameters.

## 5 SUMMARY

An object of the present disclosure is to provide an air purification device which seeks to mitigate, alleviate, or eliminate one or more of the above-identified deficiencies in the art and disadvantages singly or in any combination.

This object is obtained by an air purification device of the independent claim.

10 According to an aspect, an air purification device for separating airborne particles from a flow of air is provided. The air purification device comprises an emitter unit comprising an emitter electrode, and a filter medium arranged to attract at least a subset of the airborne particles. The filter medium comprises a conductive material. Furthermore, the emitter electrode and the filter medium comprising the conductive material are so arranged as to produce an ionizing  
15 volume for charging airborne particles present in the flow of air.

Prior art air purification devices including an ionizing unit and a filter medium generally have the ionizing unit and the filter medium at a distance from each other. It has been surprisingly found that an ionizing unit and a filter medium may be arranged adjacent to one another and that a sufficient ionizing volume, i.e. a volume where airborne particles are charged by means  
20 of an ion field, may still be produced for charging airborne particle to an extent that enhances an air purification device in relation to an air purification device without any ionization unit. The inventors have further realised that a collector electrode of the ionizing unit can be integrated in the filter medium by providing a filter medium comprising a conductive material.

By providing the filter medium comprising a conductive material and thus arranging the filter  
25 medium to act as a collector electrode, an air purification device may be provided having the same combined size as the size of a separate filter medium in an arrangement without an ionizing unit, but where the air purification device has an enhanced reduction of particles from an air flow when in use as compared to the separate filter medium. Furthermore, more evenly distributed fields over the entire filter surface will be achieved.

According to an aspect of the present disclosure, the filter medium comprising the conductive material is arranged to act as one or more collector electrodes by means of said conductive material.

The terms “ionizing unit” and “ionizer” are used herein to denote a combination of an emitter electrode and a collector electrode (or sender electrode and receiver electrode).

That the filter medium attracts at least a subset of the charged airborne particles means that the at least a subset of the charged airborne particles are entrapped in the filter medium such that they are not in the flow of air after the filter medium.

Herein the term “filter medium” refers to a filter configuration which comprises a porous structure permeable to gases.

The term “filter medium” is used herein to denote a natural or synthetic material or a manufactured article used for filtration which have a porous structure permeable to gases, and which would entrap at least a subset of airborne particles even if they and/or the airborne particles are not charged.

By air flow is meant the flow of air that passes through the device in use. The air flow may be actively generated in that it is driven by a fan or other such air displacement means, or it may be passive in that it is generated by way of the air being directed through the filter while a vehicle comprising such a device is being driven. The air flow may also be driven by a vehicle’s air conditioning system.

There are many ways of achieving a filter medium comprising a conductive material. However, the filter medium comprising a conductive material should preferably be such that an additional pressure drop resulting from the conductive material should be kept low.

In embodiments, the conductive material may form an integral part of the filter medium, such as a carbon filter layer or the like. The conductive material may also be added as a conductive particle media, e.g. by spraying or by other means providing conductive particles on a surface of within the filter media. A further alternative is to add a mesh of a conductive material, such as a metal mesh, to the filter medium, either on the surface of or in-between layers of the filter media.

In embodiments, the filter medium comprising the conductive material is connected to electrical ground or to another electric potential different from the electric potential of the emitter.

The filter medium according to the present disclosure may be provided with layers which may  
5 comprise layer configured to adhere particle matters passing through.

The layers may further comprise a conductive layer, i.e. a layer of conductive material, e.g. activated carbon. The conductive layer, e.g. activated carbon layer, is configured to be connected to ground, or to other electrical potential different from the electrical potential of the emitter, so as to, together with the emitter electrode of the emitter unit, build the required  
10 electrical field and corona discharge and hence the ionizing volume for charging airborne particles present in the flow of air. A conductive layer in the shape of an activated carbon layer may further be designed to protect people, e.g. driver and passengers of a vehicle, from harmful and unpleasant gasses.

The layers may further comprise an anti-allergen layer configured to protect against air floating  
15 allergens.

By connecting the filter medium comprising a conductive material connected to electrical ground or to another electric potential different from the electric potential of the emitter, airborne particles charged in an ionizing volume produced by the air purification device, will more likely be trapped by the filter medium. Furthermore, once a charged particle is trapped in  
20 the filter material, the charge of the particle will be neutralised. Hence, a risk of the filter medium becoming charged by the charged particles and hence not attract or even repel the charged particles is avoided.

In embodiments, the emitter electrode and filter medium comprising the conductive material are preferably arranged at distance within 10-100 millimetres, and even more preferably  
25 arranged at distance within 12-30 millimetres. The distance is preferably measured from a portion of the emitter electrode closest to a portion of the filter medium comprising the conductive material.

In embodiments, the emitter electrode and filter medium comprising the conductive material are so arranged that an ionizing volume is produced in a direction away from the filter medium

when the air purification device is in use. This enables charging of airborne particles in an air flow which first passes through the ionizing volume directed away from the filter medium and then through the filter medium in which at least a subset of the charged airborne particles are attracted. The emitter electrode may hence be arranged close to the filter medium comprising  
5 the conductive material in order to provide a emitter unit and filter medium combination with as small as possible total distance from a topmost portion of the emitter unit to a bottommost portion the filter medium, whilst maintaining an as large as possible distance from a topmost to a bottommost portion the filter medium, i.e. a thickness of the filter medium.

In further embodiments, the emitter electrode and the filter media comprising the conductive  
10 material are so arranged that an ionizing volume is produced which is adapted to a portion of a ventilation system contiguous to a position in which the air purification device is intended to be arranged.

In embodiments, the emitter electrode comprises one or more corona discharge points, wherein at least a subset of said corona discharge point is directed away from the filter medium.

By pointing at least a portion of the one or more corona discharge points away from the filter  
15 medium, an ionizing volume is produced in a direction away from the filter medium when the air purification device is in use. This enables charging of airborne particles in an air flow which first passes through the ionizing volume directed away from the filter medium and then through the filter medium in which at least a subset of the charged airborne particles are attracted. The  
20 emitter electrode may hence be arranged close to the filter medium in order to provide emitter electrode and filter medium combination with as small as possible total distance from a topmost portion of the emitter electrode to a bottommost portion the filter medium, whilst maintaining an as large as possible distance from a topmost to a bottommost portion the filter medium, i.e. a thickness of the filter medium.

The corona generated on application of a voltage to the emitter may be positive or negative.  
25 The voltage applied to the emitter electrode may be between -10 and 10kV DC, more preferably between -7 and 7 kV DC.

Corona discharge points directed away from the filter medium does not only encompass corona  
discharge points directed perpendicular away from the filter medium but alternative  
30 arrangements with smaller angles, such as 45° or the like which also produce an ionizing volume

in a direction away from the filter medium, i.e. the ionizing volume situated before the filter medium in relation to a flow of air when the device is in use, are also encompassed.

In embodiments, the emitter electrode comprises a plurality of corona discharge points. By provision of a plurality of corona discharge points, an ionizing volume may be produced with a lower voltage applied to the plurality of corona discharge points when the air purification device  
5 is in use, which is sufficient for charging airborne particle to an extent similar to an air purification device with only one corona discharge point applied with a higher voltage.

The plurality of corona discharge points could for example be a plurality of tips, carbon brushes etc. to produce points where a density of an electrical field is sufficient to produce a corona.

10 The plurality of corona discharge points may be arranged on a single emitter electrode in which case they are electrically connected to one another. However, it is also possible for there to exist a plurality of emitter electrodes which are electrically separate from one another, but which work together to generate an ion field in use. For example, it is possible for there to be a pair of emitter electrodes, electrically apart from one another, but each comprises a plurality of  
15 corona discharge points. In such an embodiment it is possible for the corona discharge points on separate emitter electrodes to point in the same direction or substantially opposite directions.

Similarly, it is possible for the filter comprising the conducting material to form a single, grounded collector electrode for corona discharge points. However, it is also possible for the  
20 filter comprising the conducting material to be divided into a plurality of collector electrodes.

In embodiments, the filter media comprising the conductive material is arranged such that said plurality of corona discharge points of the emitter electrode are at a substantially same distance from respective portions of filter medium comprising the conductive material. This enables production of a substantially uniform ionizing volume when the air purification device is in use,  
25 thereby providing substantially uniform charging of airborne particles in the ionizing volume.

In further embodiments, the emitter electrode is an elongated structure and said plurality of coronal discharge points are distributed along a length of the emitter electrode, the collector electrode is an elongated structure, and the emitter electrode and the collector electrode are arranged substantially parallel to one another. This enables production of a substantially

uniform ionizing volume when the air purification device is in use, thereby providing substantially uniform charging of airborne particles in the ionizing volume.

In embodiments, the emitter electrode is a flattened and elongated structure arranged such that it is flattened in a plane substantially parallel to the flow of air. The emitter electrode being  
5 flattened in a plane substantially parallel to the flow of air when the air purification device is in use, enables a reduction of influence of the emitter electrode on the flow of air. The emitter electrode may include one or more corona discharge points, and at least a subset of the one or more corona discharge points may be arranged on an edge of the emitter electrode such that the at least a subset of the plurality of corona discharge points is directed away from the filter  
10 medium.

In embodiments, the air purification device comprises two or more emitter units comprising emitter electrodes.

In embodiments, the emitter unit further comprises an emitter carrier for holding the emitter electrode and for electrically isolating the emitter electrode from the filter medium comprising  
15 the conductive material.

In further embodiments, the emitter unit is flexibly connected to the filter medium so as to allow for deformation of the filter medium whilst the emitter unit is attached to the filter medium.

According to an aspect of the present disclosure, the air purification device is configured to be  
20 operated by means of supplying power to emitter electrode and filter medium comprising the conductive material so as to facilitate producing ionizing volume for charging airborne particles in the flow of air.

In embodiments, the air purification device further comprises a power supply, a first connector connecting the power supply to the emitter electrode, and a second connector connecting the  
25 power supply to the filter medium comprising the conductive material.

In embodiments, the second connector connecting the power supply to the filter medium comprising the conductive material, may be a fastener for fastening a housing comprising the power supply to a wall of a box or frame in which the filter medium comprising the conductive material is arranged when the air purification device is in use. The fastener may be electrically

connected to electrical ground or to a voltage different from a voltage supplied to the emitter electrode when the air purification device is in use. The fastener may further be electrically connected to the conductive material of the filter medium when the air purification device is in use.

5 According to an aspect of the present disclosure, the second connector connecting the power supply to the filter medium comprising the conductive material, may comprise a fastener member configured to provide connection to a conductive wall portion of a box or frame in which the filter medium comprising the conductive material, wherein said conductive wall portion is configured to be in contact with the conductive material of the filter medium so as to  
10 connect the filter medium comprising the conductive material to electrical ground or to a voltage different from a voltage supplied to the emitter electrode when the air purification device is in use. The grounded fastener member may have a clamp configuration for easy attachment to said conductive wall portion, so as to facilitate connecting the filter medium comprising the conductive material to electrical ground via said conductive wall portion being  
15 connected to the conductive layer of the filter medium. The fastener having a clamp configuration may be configured to a housing comprising the power supply to a wall of a box or frame in which the filter medium comprising the conductive material is arranged when the air purification device is in use.

According to an aspect of the present disclosure, the second connector connecting the power  
20 supply to the filter medium comprising the conductive material, may comprise a needle member configured to provide connection with the conductive material of the filter medium so as to connect the filter medium comprising the conductive material to electrical ground. The grounded needle member may thus be configured to connect the filter medium comprising the conductive material to electrical ground.

25 In embodiments, the box or frame has the shape of a rectangle or square with one corner cut off and the housing has the shape of a triangle adapted to be fastened to a wall of the housing at the cut off corner, such that the combined housing and box or frame has the shape of a complete rectangle or square, respectively.

## BRIEF DESCRIPTION OF THE DRAWINGS

The foregoing will be apparent from the following more particular description of the example embodiments, as illustrated in the accompanying drawings in which like reference characters refer to the same parts throughout the different views. The drawings are not necessarily to  
5 scale, emphasis instead being placed upon illustrating the example embodiments.

Figure 1a-c are simplified cross sectional views of embodiments of an air purification device of the present disclosure.

Figure 2 is a perspective view of an emitter electrode of a first type which can be used in embodiments of an air purification device of the present disclosure.

10 Figure 3 is a perspective view of an emitter electrode of a second type which can be used in embodiments of an air purification device of the present disclosure.

Figures 4a-d are an example configuration of and details of an air purification device according to the present disclosure.

15 Figures 5 is an example configuration of an air purification device according to the present disclosure.

Figure 6 is a simplified cross sectional view of an electrical ground configuration 160 for an air purification device according to a first aspect of the present disclosure.

Figure 7 is a simplified cross sectional view of an electrical ground configuration for an air purification device according to a second aspect of the present disclosure.

20

## DETAILED DESCRIPTION

Aspects of the present disclosure will be described more fully hereinafter with reference to the accompanying drawings. The device disclosed herein can, however, be realized in many different forms and should not be construed as being limited to the aspects set forth herein.

25 Like numbers in the drawings refer to like elements throughout.

The terminology used herein is for the purpose of describing particular aspects of the disclosure only, and is not intended to limit the invention. As used herein, the singular forms "a", "an" and "the" are intended to include the plural forms as well, unless the context clearly indicates otherwise.

- 5 Figure 1a-c are simplified cross sectional views of embodiments of an air purification device of the present disclosure.

Figure 1a is a simplified cross section view of an embodiment of an air purification device 10 of the present disclosure. The air purification device 10 comprises an emitter unit 12 comprising an emitter electrode 14 and an emitter carrier 16. The emitter electrode 14 of the embodiment  
10 has arranged thereon one or more (a plurality of) corona discharging points 20 in electrical contact with the emitter electrode. The air purification device 10 further comprises a filter medium 22 comprising a conductive material. The emitter electrode 14 and the filter medium 22 comprising the conductive material are arranged for charging airborne particles present in a flow of air 18 when the air purification device 10 is in use. This is done by generation of corona  
15 on the one or more corona discharging points 20 by application of a positive or negative voltage to the emitter electrode 14. The voltage applied to the emitter electrode 14 may be between -10 and 10 kV DC, and more preferably between -7 and 7 kV DC. The filter medium 22 comprising the conductive material may for example be connected to electrical ground or the opposite voltage in relation to the emitter electrode 14. The filter medium 22 comprising the conductive  
20 material is further arranged to attract at least a subset of the charged airborne particles in the flow of air 18. The emitter unit 12 comprising the emitter electrode 14 and the filter medium 22 comprising the conductive material are arranged adjacent to one another with the emitter carrier 16 isolating the emitter electrode 14 from the filter medium 22 comprising the conductive material. They are further preferably arranged such that the emitter electrode 14  
25 and the filter medium 22 comprising the conductive material are at a distance within 10-100 millimetres, and more preferably arranged at distance within 12-30 millimetres. The distance is measured from a portion of the emitter electrode 14 closest to a portion of the filter medium 22 comprising the conductive material. The distance is for example adapted such that the risk of arcs being produced between the emitter electrode 14 and the filter medium 22 comprising  
30 the conductive material is minimized. The filter medium 22 is arranged after the emitter unit in the flow of air 18.

There are many ways of achieving the filter medium 22 comprising the conductive material. However, the filter medium comprising the conductive material should preferably be such that an additional pressure drop resulting from the conductive material should be kept low.

The conductive material may form an integral part of the filter medium, such as a carbon filter layer or the like including activated carbon. The conductive material may also be added as a conductive particle media, e.g. by spraying or by other means providing conductive particles on a surface of within the filter media. A further alternative is to add a mesh of a conductive material, such as a metal mesh, to the filter medium, either on the surface of or in-between layers of the filter media.

In the air purification device 10, the emitter unit 12 comprising the emitter electrode 14 and the filter medium 22 comprising the conductive material are preferably arranged so as to reduce a total distance from a topmost portion of the emitter unit 12 to a bottommost portion the filter medium 22. However, it would also possible for at least a portion of the emitter unit 12 to be arranged in recesses into the filter medium 22. For example, at least a portion of the emitter unit 12 could be arranged in recesses into the filter medium 22 comprising the conductive material.

The one or more corona discharge points 20 are directed away from the filter medium 22 to produce an ionizing volume in a direction away from the filter medium 22 when the air purification device is in use. Corona discharge points 20 directed away from the filter medium 22 does not only encompass corona discharge points 20 directed perpendicular away from the filter medium 22 but alternative arrangements with smaller angles, such as 45° or the like which also produce an ionizing volume in a direction away from the filter medium 22, i.e. the ionizing volume situated before the filter medium 22 in relation to the flow of air 18 when the device 10 is in use, are also encompassed.

The one or more corona discharge points 20 could for example be a plurality of tips as shown in Figure 1a. In alternative, carbon brushes or other means can be used to produce points where a density of an electrical field is sufficient to produce a corona.

Figure 1b is a simplified cross section view of an embodiment of the air purification device 10 in figure 1a, schematically illustrating the ionizing volume V according to an aspect of the present disclosure.

In figure 1b the power supply P according to an aspect of the present disclosure is schematically illustrated. The air purification device 10 thus comprises a power supply P.

The power supply comprises or is operably connected to a first connector C1 connecting the power supply to the emitter electrode 14 and a second connector C2 connecting the power supply to the filter medium 22 comprising the conductive material.

The emitter electrode 14 and the filter medium 22 comprising the conductive material are arranged for charging airborne particles present in a flow of air 18 when the air purification device 10 is operated. The emitter electrode 14 and the filter medium 22 comprising the conductive material are so arranged as to produce said ionizing volume V for charging airborne particles present in the flow of air 18.

This is done by generation of corona on the one or more corona discharging points 20 by application of a positive or negative voltage to the emitter electrode 14. The voltage applied to the emitter electrode 14 may be between -10 and 10 kV DC, and more preferably between -7 and 7 kV DC, in fig. 1b the voltage applied to the emitter electrode being -7 kV. The voltage is here applied to the emitter electrode 14 via the first connector C1. The filter medium 22 comprising the conductive material is according to the example illustrated in fig. 1b connected to electrical ground G.

Figure 1a and 1b schematically illustrates an air purification device 10 according to the present disclosure, having a single emitter configuration. According to an aspect of the present disclosure, single emitter configuration may refer to the air purification device being provided with a single emitter unit 12. According to an aspect of the present disclosure, single emitter configuration may refer to the air purification device being provided with a single emitter electrode 14. Hereby, as illustrated in fig. 1b, a single ionizing volume V for charging airborne particles present in the flow of air 18 is produced.

Figure 1c schematically illustrates an air purification device 110 according to the present disclosure, having a dual emitter configuration. According to an aspect of the present disclosure,

dual emitter configuration may refer to the air purification device being provided with dual emitter units 12. According to an aspect of the present disclosure, dual emitter configuration may refer to the air purification device being provided with dual emitter electrodes 14. Hereby, as illustrated in fig. 1c, dual ionizing volume V1, V2 for charging airborne particles present in the flow of air 18 is produced.

The air purification device 110 according to the present disclosure as illustrated in figure 1c, comprises dual emitter units 12, i.e. a first emitter unit 12 and a second emitter unit 12. The respective emitter unit 12 comprises an emitter electrode 14 and an emitter carrier 16. The first emitter unit thus comprises a first emitter electrode and a first emitter carrier and the second emitter unit comprises a second emitter electrode and a second emitter carrier. The first emitter electrode 14 and the second emitter electrode 14 of the embodiment has arranged thereon one or more, e.g. a plurality of, corona discharging points 20 in electrical contact with the emitter electrode. The air purification device 110 further comprises a filter medium 22 comprising a conductive material.

Here the first emitter electrode 14 and the filter medium 22 comprising the conductive material are so arranged as to produce a first ionizing volume V1 for charging airborne particles present in the flow of air 18, and the second emitter electrode 14 and the filter medium 22 comprising the conductive material are so arranged as to produce a second ionizing volume V2 for charging airborne particles present in the flow of air 18.

By thus providing a dual emitter configuration with a first and second emitter electrode 14, it is facilitated to produce more ions by thus producing dual ionizing volumes such that charging of more airborne particles present in the air flow is facilitated. The arrangement with a filter medium 22 comprising a conductive material facilitates such a dual emitter configuration.

The air purification device according to the present disclosure may comprise any suitable number of emitter units

Figure 2 is a perspective view of an emitter electrode 14 of a first type which can be used in embodiments of an air purification device of the present disclosure, such as the air purification device 10 disclosed in figure 1a-b and the air purification device 110 disclosed in fig. 1c. The emitter electrode 14 includes a plurality of corona discharge points 20. The plurality of corona

discharge points are arranged in the same direction and may when arranged in an air purification device be directed away from the filter medium. Embodiments are however envisaged where at least one or more of the plurality of discharge points 20 are directed in another direction.

- 5 The plurality of corona discharge points 20 could for example be a plurality of tips as shown in figure 2. In alternative, carbon brushes or other means can be used to produce points where a density of an electrical field is sufficient to produce a corona.

In alternative to the blade 14 and tips 20 both being vertical as disclosed in figure 2, the blade 14 may be horizontal and the tips 20 may be bent with an angle, such as 45-70°, upwards from  
10 the edge of the horizontal blade 14.

Figure 3 is a perspective view of an emitter electrode 34 of a second type which can be used in embodiments of an air purification device of the present disclosure, such as the air purification device 10 disclosed in figure 1. The emitter electrode 34 is of a cylindrical shape and may for example be formed using a copper wire.

- 15 Figure 4a is an example configuration of an air purification device 40 according to the present disclosure. An emitter unit 42 of the air purification device 40 comprises an emitter electrode 44 and an emitter carrier 46 and a filter medium 22 comprising a conducting material. The emitter carrier 46 is arranged for holding the emitter electrode 44 and for isolating the emitter electrode 44 from the filter medium 22 comprising the conductive material. The emitter carrier  
20 46 is made of a non-conductive material, such as non-conductive plastic. The emitter electrode 44 has arranged thereon a plurality of corona discharging points in electrical contact with the emitter electrode 44. The filter medium 22 comprising a conducting material is arranged in a frame or box 50. The air purification device 40 further comprises a housing 52 comprising a power supply (not shown) and further electronics (not shown) for operating the air purification  
25 device 40. The emitter electrode 44 and the filter medium 22 comprising the conducting material are arranged for charging airborne particles present in a flow of air when the air purification device 40 is in use. This is done by generation of corona on the plurality of corona discharging points of the emitter electrode 44 by application of a positive or negative voltage to the emitter electrode 44. The voltage is applied by the power supply (not shown) in the housing  
30 52 via an electric connector, such as a power cable 54 as shown in figure 4a. The voltage applied

to the emitter electrode 44 may be between -10 and 10 kV DC, and more preferably between -7 and 7 kV DC.

The filter medium 22 comprising the conductive material may for example be connected to electrical ground or the opposite voltage in relation to the emitter electrode 44, such that a potential difference is produced between the emitter electrode 44 and the filter medium 22 comprising the conductive material. The filter medium 22 comprising the conductive material is further arranged to attract at least a subset of the charged airborne particles in a flow of air. The emitter unit 42 comprising the emitter electrode 44 and the filter medium 22 comprising the conductive material are arranged adjacent to one another with the emitter carrier 46 isolating the emitter electrode 44 from the filter medium 22 comprising the conductive material. They are further preferably arranged such that the emitter electrode 44 and the filter medium 22 comprising the conductive material are at a distance within 10-100 millimetres, and more preferably arranged at distance within 12-30 millimetres. The distance is measured from a portion of the emitter electrode 44 closest to a portion of the filter medium 22 comprising the conductive material. The distance is for example adapted such that the risk of arcs being produced between the emitter electrode 44 and the filter medium 22 comprising the conductive material is minimized.

The air purification device 40 may be designed such that the frame or box 50 has the same size and shape as a standard filter box comprising a filter media normally placed in a filter compartment of a vehicle. Hence, the air purification device 40 can replace the standard filter box without the need for any adaptation of the actual filter compartment. In use, a flow of air is directed from above the emitter electrode 44 and towards the filter medium 22, i.e. first passing through an ionizing volume produced by the emitter electrode 44 and the filter medium 22 comprising the conductive material, and then through the filter medium 22. The ionizing volume can be produced such that is adapted to a portion of a ventilation system contiguous and upstream to the filter compartment. This can be done by adaptation of the emitter electrode 42, the corona discharge tips 20 and the filter medium 22 comprising the conductive material. By such adaptation, the time and distance travelled by airborne particles in the flow of air in the ionizing volume can be prolonged in order to increase the portion/percentage of particles being charged and hence the number of particles attracted to the filter medium and

removed from the flow of air before entering the space after the filter medium, e.g. a cabin of a vehicle the air purification device is arranged in.

In use, the air purification device 40 is arranged such that the emitter unit 42 comprising the emitter electrode 44, and the filter medium 22 comprising the conductive material are arranged  
5 adjacent to one another. More specifically, the emitter electrode 44 and the filter medium 22 are arranged so as to reduce a total distance from a topmost portion of the emitter unit 42, to a bottommost portion the filter medium 22.

Even though figure 4a shows an air purification device 40 including one emitter unit 42 comprising one emitter electrode 44, it is understood that the air purification device 40 can be  
10 provided with two or more emitter units 42 comprising emitter electrodes 44. The number of emitter units 42 and the arrangement of them depends on the ionization volume to be formed and is further in some cases a trade of between enabling a large ionization volume and maintaining a low pressure drop through the air purification device 40.

Figure 4b is a first detail of the air purification device 40 of figure 4a. A portion of the filter  
15 medium 22 comprising the conductive material is show together with a portion of the emitter unit 42 comprising the emitter electrode 44 and the emitter carrier 46. On the emitter electrode the corona discharging points in the form of tips (pins) 20 are arranged and directed away from the filter medium 22 comprising the conductive material. Between each tip 20, protrusions 56  
20 on the emitter carrier 46 are arranged. The protrusions 56 are made of a non-conductive material, such as non-conductive plastic. Such protrusions 56 are advantageous in order to protect a person handling the air purification device 40, e.g. when installing it, from getting in contact with the corona discharging points 20 as they are generally sharp and may cause cuts and may also be damaged themselves by becoming bent or less sharp.

The emitter unit 42 further comprises attachment parts 58. The attachment parts 58 are  
25 arranged such that they attach to the filter medium 22 comprising the conductive material. The attachment parts 58 are preferably movably arranged on the emitter carrier 46 such that, if the filter medium 22 is deformed to an extent, e.g. by bending along pleats of the filter medium, the attachment parts 58 can keep the emitter carrier 46 attached to the filter medium 22, whilst at the same time be moved in relation to the emitter carrier 46 to accommodate the  
30 deformation of the filter medium 22. The attachment parts 58 are preferably arranged in a way

so that they allow free positioning on filter regardless relative positioning of pleats of the filter medium 22 and such that they provide easy and secure mounting on filter. The attachment parts 58 should further be arranged to ensure positioning of emitter unit 42 substantially perpendicular to pleats. This is preferable in order to keep a low pressure drop and high utilisation of filter area. As shown in figure 4b, the attachment parts 58 may be slidably arranged on a rod 60 of the emitter carrier 46. If an attachment part 58 is clipped onto a pleat of the filter medium 22 and the filter medium 22 is deformed by bending along the pleat onto which the attachment part 58 is clipped, the attachment part 58 may slide along the rod 60 to accommodate the movement of the pleat onto which the attachment part is clipped. Furthermore, having the attachment parts 58 in the form of clips slidably arranged on rods 60, each attachment part 58 can be easily and securely clipped onto a pleat of the filter medium 22 by sliding the attachment part 58 in line with a position of a corresponding pleat of the filter medium 22. In order to enable such adaptation of the position of the attachment parts 58, the length of each rod 60 should be longer than the distance between two pleats of the filter medium 22.

The emitter electrode 44 may for example consist of a blade parallel with the filter medium 22 with the tips 20 on one edge of the blade and bent upwards away from the filter medium 22. This allows for flat cost effective manufacturing. Furthermore, the emitter electrode 44 may thus bend with the filter medium 22 when mounted on the emitter carrier to enable a desired direction of the tips 20 in relation to the filter medium. The flat blade parallel with the filter medium 22 also allows for a low design of the overall combination of the emitter unit 42 and the filter medium 22 comprising the conductive material. Additionally, since the tips 20 are directed away from the filter medium, they can be made short to further enable a low design.

Figure 4c is a second detail of the air purification device 40 of figure 4a. The housing 52 comprising the power supply (not shown) and further electronics (not shown) for operating the air purification device is attached to a wall of the frame or box 50 by means of a fastener 62. The fastener 52 is be electrically connected to electrical ground or to a voltage different from a voltage supplied to the emitter electrode when the air purification device is in use. The fastener 62 is further electrically connected to the conductive material of the filter medium 22 when the air purification device is in use.

As seen in figure 4a, the box or frame 50 has the shape of a rectangle with one corner cut off and the housing 52 has the shape of a triangle adapted to be fastened to a wall of the housing 52 at the cut off corner, such that the combined housing 52 and box or frame 50 has the shape of a complete rectangle. Even though the housing 52 has the shape of a triangle, the housing 52 and box or frame 50 may have other shapes. Using a cut off corner of the box or frame 50 and a triangular housing 52 has been selecting to simplify manufacturing of the filter.

Figure 4d shows the housing 52 and the fastener 62 when detached from the box or frame. The fastener, e.g. made of metal, is a clip which is attached to the housing and arranged to be clipped onto a wall of the box or frame. The fastener 62 includes a first flat portion attached to a horizontal wall of the housing 52 and a second portion parallel with the first portion including hooks 64 with optional rolled tips. The hooks 64 with the optional rolled tips are arranged to slide into to pockets (pleats) of the filter to come in electrical contact with the conductive material of the filter medium. The conductive material of the filter medium may for example be a carbon filter layer including activated carbon, a conductive material disposed on the surface of a layer of the filter medium or a conductive mesh.

On the housing 52 is also a protrusion 66 including a hole 68. The hole 68 allows a power cable and/or a light guide to pass from inside the box or frame 50 and/or the housing 52. The protrusion 66 may be part of a fastener for secure fastening and positioning of the housing 52 and/or the entire box or frame 50 and to ensure air tightness.

Figure 5 is an example configuration of an air purification device 140 according to the present disclosure. The air purification device 140 is a dual emitter configuration having a first and second emitter unit 142. The respective emitter unit 142 of the air purification device 140 comprises an emitter electrode 144 and an emitter carrier 146 and a filter medium 22 comprising a conducting material. The first emitter unit 142 comprises a first emitter electrode 144 and a first emitter carrier 146 and the second emitter unit 142 comprises a first emitter electrode 144 and a first emitter carrier 146. The first and second emitter carrier 146 is arranged for holding the first and second emitter electrode 144 respectively, and for isolating the first and second emitter electrode 144 from the filter medium 22 comprising the conductive material. By thus providing a dual emitter configuration with a first and second emitter electrode, it is facilitated to produce more ions by thus producing dual ionizing volumes such

that charging of more airborne particles present in the air flow is facilitated. The arrangement with a filter medium comprising a conductive material facilitates such a dual emitter configuration.

The first and second emitter carrier 146 are made of a non-conductive material, such as non-  
5 conductive plastic. The first and second emitter electrode 144 has arranged thereon a plurality of corona discharging points in electrical contact with the emitter electrode 144. The respective emitter electrode 144 may comprise said plurality of corona discharging points. The filter medium 22 comprising a conducting material is arranged in a frame or box 150. The air purification device 140 further comprises a housing 152 comprising a power supply and further  
10 electronics for operating the air purification device 140. The first and second emitter electrode 144 and the filter medium 22 comprising the conducting material are arranged for charging airborne particles present in a flow of air when the air purification device 140 is in use. This is done by generation of corona on the plurality of corona discharging points of the first and second emitter electrode 144 by application of a positive or negative voltage to the respective  
15 emitter electrode 144. The voltage is applied by the power supply in the housing 152 via an electric connector, such as a power cable 154 as shown in figure 5. The voltage applied to the first and second emitter electrode 144 may be between -10 and 10 kV DC, and more preferably between -7 and 7 kV DC. The electric connector, such as a power cable 154, for supplying voltage to the first and second emitter unit 142, may comprise a power cable portion 154a connected  
20 to the first emitter unit 142 and hence first emitter electrode 144. The first and second emitter unit 142 are according to an aspect of the present disclosure operably connected by means of the electric connector, such as the power cable 154 as shown in figure 5, wherein the power cable 154 may comprise a power cable portion 154b connecting the first and second emitter unit 142. Here the voltage is applied to the first emitter unit 142 and hence the first emitter  
25 electrode 144 via the power cable 154 and hence the power cable portion 154a, wherein the voltage is further applied to the second emitter unit 142 and hence second emitter electrode 144 via the first emitter unit 142 and hence via the power cable portion 154b.

The filter medium 22 comprising the conductive material may for example be connected to electrical ground or the opposite voltage in relation to the emitter electrode 144, such that a  
30 potential difference is produced between the emitter electrode 144 and the filter medium 22

comprising the conductive material. The filter medium 22 comprising the conductive material is further arranged to attract at least a subset of the charged airborne particles in a flow of air.

The first emitter unit 142, comprising the first emitter electrode 144, and the filter medium 22 comprising the conductive material are arranged adjacent to one another with the first emitter carrier 146 isolating the emitter electrode 144 from the filter medium 22 comprising the conductive material. The second emitter unit 142, comprising the second emitter electrode 144, and the filter medium 22 comprising the conductive material are arranged adjacent to one another with the second emitter carrier 146 isolating the emitter electrode 144 from the filter medium 22 comprising the conductive material. The first emitter electrode 144 is further arranged relative to the filter medium 22 such that the first emitter electrode 144 and the filter medium 22 comprising the conductive material are at a distance within 10-100 millimetres, and more preferably arranged at distance within 12-30 millimetres. The second emitter electrode 144 is further arranged relative to the filter medium 22 such that the second emitter electrode 144 and the filter medium 22 comprising the conductive material are at a distance within 10-100 millimetres, and more preferably arranged at distance within 12-30 millimetres. The distance is measured from a portion of the respective emitter electrode 144 closest to a portion of the filter medium 22 comprising the conductive material. The distance is for example adapted such that the risk of arcs being produced between the emitter electrode 144 and the filter medium 22 comprising the conductive material is minimized.

The first and second emitter units 142 may according to an aspect have essentially the same shape and configuration. The first and second emitter units 142 may according to an aspect have an elongated shape with the plurality of corona discharging points arranged and distributed centrally along the length of the elongated emitter unit. The first and second emitter units 142 having an elongated shape are according to an aspect of the present disclosure configured to be arranged in connection to the filter medium 22 at a distance from each other and essentially parallel to each other, i.e. configured to run essentially parallel to each other along each other at a certain distance from each other. The first and second emitter units 142 having an elongated shape are according to an aspect of the present disclosure configured to be arranged in connection to the filter medium 22 at a distance from each other so as to facilitate optimizing adjacent ionizing volumes for charging airborne particles present in the flow of air.

The air purification device 140 may be designed such that the frame or box 150 has the same size and shape as a standard filter box comprising a filter media normally placed in a filter compartment of a vehicle. Hence, the air purification device 140 can replace the standard filter box without the need for any adaptation of the actual filter compartment. In use, a flow of air is directed from above the emitter electrode 144 and towards the filter medium 22, i.e. first passing through an ionizing volume produced by the emitter electrode 144 and the filter medium 22 comprising the conductive material, and then through the filter medium 22. The ionizing volume can be produced such that is adapted to a portion of a ventilation system contiguous and upstream to the filter compartment. This can be done by adaptation of the first and second emitter electrode 144 and their arrangement relative to each other, the corona discharge tips and the filter medium 22 comprising the conductive material. By such adaptation, the time and distance travelled by airborne particles in the flow of air in the ionizing volume can be prolonged in order to increase the portion/percentage of particles being charged and hence the number of particles attracted to the filter medium 22 and removed from the flow of air before entering the space after the filter medium, e.g. a cabin of a vehicle in which the air purification device 140 is arranged in.

In use, the air purification device 140 is arranged such that the first and second emitter unit 142 comprising the first and second emitter electrode 144, and the filter medium 22 comprising the conductive material are arranged adjacent to one another. More specifically, the first emitter electrode 144 is arranged relative to the filter medium 22 so as to reduce a total distance from a topmost portion of the first emitter unit 142, to a bottommost portion the filter medium 22, and the second emitter electrode 144 is arranged relative to the filter medium 22 so as to reduce a total distance from a topmost portion of the second emitter unit 142, to a bottommost portion the filter medium 22.

Even though figure 5 shows an air purification device 140 including two emitter units 142, each comprising an emitter electrode 144, it is understood that the air purification device 140 can be provided with one emitter unit as illustrated e.g. in fig. 4a, or more than two emitter units comprising emitter electrodes. The number of emitter units and the arrangement of them depends on the ionization volume to be formed and is further in some cases a trade off between enabling a large ionization volume and maintaining a low pressure drop through the air purification device.

On the first and second emitter electrode 144 the corona discharging points in the form of tips may be arranged and directed away from the filter medium 22 comprising the conductive material. Between each tip, protrusions of a non-conductive material may be arranged on the first and second emitter carrier 146 so as to protect an operator handling the air purification device 140 from the sharp tips.

The emitter unit 142 further comprises attachment parts 158. The attachment parts 158 are arranged such that they attach to the filter medium 22 comprising the conductive material. The attachment parts 158 may as illustrated in fig. 5 have an arc shaped configuration and may be arranged in connection to end portions of the emitter carrier 146 of the respective emitter unit 142. The attachment parts 158 may as illustrated in fig. 5 be arranged in connection to side portions of the emitter carrier 146 of the respective emitter unit 142 so that the attachment parts 158 for the first emitter carrier 146 face away from the attachment parts 158 for the second emitter carrier 146. The attachment parts 158 may be configured to keep the first and second emitter carrier 146 attached to the filter medium 22, whilst at the same time be moved in relation to the emitter carrier 146 to accommodate the deformation of the filter medium 22. The attachment parts 158 are preferably arranged in a way so that they allow free positioning on filter regardless relative positioning of pleats of the filter medium 22 and such that they provide easy and secure mounting on filter.

The housing 152 comprising the power supply and further electronics for operating the air purification device may be attached to a wall of the frame or box 150 by means of a fastener. The fastener may be electrically connected to electrical ground or to a voltage different from a voltage supplied to the first and second emitter electrodes when the air purification device 140 is in use. The fastener may further be electrically connected to the conductive material of the filter medium 22 when the air purification device is in use.

A power connector C, e.g. a power cable, is connected to the power supply of the housing 152 and configured to provide low voltage in wherein the power supply is configured to provide high voltage out, e.g. to the emitter electrodes 144.

The air purification device 140 may comprise an electrical configuration 160 for providing electrical connection of the housing 152 comprising the power supply and further electronics to the conductive material of the filter medium 22 when the air purification device is in use. The

electrical configuration 160 may according to an aspect be an electrical ground configuration configured to provide ground connection to the conductive material of the filter medium 22 when the air purification device is in use. The electrical configuration 160 may further be configured to attach the housing to a wall portion of the frame or box 150. The electrical  
5 configuration may comprise a fastener member configured to attach the housing to a wall portion of the frame or box 150. The electrical configuration 160 may according to an aspect of the present disclosure be an electrical ground configuration 160 as described below with reference to fig. 6. . The electrical configuration 160 may comprise a grounded fastener member configured to provide connection to a conductive wall portion of the frame or box 150, wherein  
10 said conductive wall portion is configured to be in contact with the conductive material, e.g. conductive layer, of the filter medium so as to connect the filter medium comprising the conductive material to electrical ground.

As seen in figure 5, the box or frame 150 has the shape of a rectangle with one corner cut off and the housing 152 has the shape of a triangle adapted to be fastened to a wall of the housing  
15 152 at the cut off corner, such that the combined housing 152 and box or frame 150 has the shape of a complete rectangle. Even though the housing 152 has the shape of a triangle, the housing 152 and box or frame 150 may have other shapes. Using a cut off corner of the box or frame 150 and a triangular housing 152 has been selecting to simplify manufacturing of the filter.

20 Figure 6 is a simplified cross sectional view of an electrical ground configuration 160 for an air purification device according to a first aspect of the present disclosure.

The electrical ground configuration 160 is configured to provide ground connection to the conductive material 22A of the filter medium 22 when the air purification device is in use. The electrical ground configuration 160 is configured to provide connection of the power supply of  
25 the air purification device to the conductive material 22A of the filter medium so as to connect filter medium 22 with the conductive material 22A to electrical ground when the air purification device is in use. The electrical ground configuration 160 is configured to attach a ground configuration providing electrical ground G to a conductive material of the air purification device according to the present disclosure, e.g. a conductive material of a frame W of the air  
30 purification device/filter medium 22, e.g. a wall portion W comprising conductive material.

The electrical ground configuration 160 may comprise a grounded fastener member 162 configured to attach electrical ground G to conductive material of the frame W/ wall portion W of the air purification device according to the present disclosure. The fastener member 162 comprises conductive material and may be e.g. a metal plate so as to facilitate connecting the filter medium 22 with the conductive material 22A to electrical ground G. The fastener member 162 has according to this example a clamp configuration arranged to provide a grip function over a portion of the frame W/ the wall portion W comprising conductive material, facilitating electrical connection there between. The conductive material of the frame W/wall portion W of the electrical ground configuration 160 is configured to have surface contact to the conductive material 22A, here conductive layer 22A of the filter medium 22, so as to facilitate connecting the filter medium 22 with the conductive material 22A to electrical ground G.

According to an aspect of the present disclosure, the air purification device may thus comprise an electrical ground configuration 160 comprising a grounded fastener member 162 configured to provide connection to a conductive wall portion W of the air purification device, wherein said conductive wall portion is configured to be in contact with the conductive material 22A, e.g. conductive layer, of the filter medium so as to connect the filter medium 22 comprising the conductive material 22A to electrical ground. The grounded fastener member 162 is thus configured to connect the filter medium 22 comprising the conductive material 22A to electrical ground via a conductive wall portion W being connected to the conductive layer 22A of the filter medium.

According to an aspect of the present disclosure, the air purification device comprises a first connector configured to connect the power supply to the emitter electrode, and a second connector configured to connect the power supply to the filter medium comprising the conductive material, wherein said second connector, according to this embodiment, comprises said fastener member 162.

Hereby efficient grounding of the filter medium 22 is facilitated. The simplified cross sectional view of the electrical ground configuration 160 may be a simplified cross sectional view A-A of the electrical configuration 160 described above with reference to fig. 5.

Figure 7 is a simplified cross sectional view of an electrical ground configuration 260 for an air purification device according to a second aspect of the present disclosure.

The electrical ground configuration 260 configured to provide ground connection to the conductive material 22A of the filter medium 22 when the air purification device is in use. The electrical ground configuration 260 is configured to provide connection of the power supply of the air purification device to the conductive material 22A of the filter medium so as to connect  
5 filter medium 22 with the conductive material 22A to electrical ground when the air purification device is in use.

The electrical ground configuration 260 comprises a grounded needle member 262 configured to be attached to and provide an electric contact with the conductive material 22A of the filter medium 22 so as to provide grounding of the filter member 22. The filter medium 22 may have  
10 a crimped, i.e. wavy, configuration, wherein the needle member 262 may be introduced into and through portions of the filter member 22 so as to connect to the conductive material 22A on more than one wave depending on the length of the needle member 262, here to waves, of the filter medium.

According to an aspect of the present disclosure, the air purification device may thus comprise  
15 an electrical ground configuration 260 comprising a grounded needle member 262 configured to provide connection with the conductive material 22A, e.g. conductive layer, of the filter medium 22 so as to connect the filter medium 22 comprising the conductive material 22A to electrical ground. The grounded needle member 262 is thus configured to connect the filter medium 22 comprising the conductive material 22A to electrical ground.

20 According to an aspect of the present disclosure, the air purification device comprises a first connector configured to connect the power supply to the emitter electrode, and a second connector configured to connect the power supply to the filter medium comprising the conductive material, wherein said second connector, according to this embodiment, comprises said needle member 262.

25 By thus utilizing such a grounded needle member 262 efficient grounding of the filter medium 22 is facilitated.

It should be noted that the word “comprising” does not necessarily exclude the presence of other elements or steps than those listed and the words “a” or “an” preceding an element do not exclude the presence of a plurality of such elements. It should further be noted that any

reference signs do not limit the scope of the claims, that the example embodiments may be implemented at least in part by means of both hardware and software, and that several “means”, “units” or “devices” may be represented by the same item of hardware.

In the drawings and specification, there have been disclosed exemplary embodiments.

- 5 However, many variations and modifications can be made to these embodiments. Accordingly, although specific terms are employed, they are used in a generic and descriptive sense only and not for purposes of limitation, the scope of the embodiments being defined by the following claims.

## CLAIMS

1. Air purification device for separating airborne particles from a flow of air, the air purification device comprising:
  - an emitter unit comprising an emitter electrode; and
  - 5 a filter medium arranged to attract at least a subset of the airborne particles, wherein the filter medium comprises a conductive material, and
  - wherein the emitter electrode and the filter medium comprising the conductive material are so arranged as to produce an ionizing volume for charging airborne particles present in the flow of air.
- 10 2. Air purification device according to claim 1, wherein the conductive material is one of a sheet of activated carbon, conductive particle media, and a conductive mesh.
3. Air purification device according to any one of claims 1 and 2, wherein the filter medium
- 15 comprising the conductive material is connected to electrical ground.
4. Air purification device according to any one of claims 1-3, wherein the emitter electrode and filter medium are arranged at distance within 10-100 millimetres.
- 20 5. Air purification device according to any one of claims 1-3, wherein the emitter electrode and filter medium are arranged at distance within 12-30 millimetres.
6. Air purification device according to any one of claims 1-5, wherein the emitter electrode comprises one or more corona discharge points.
- 25 7. Air purification device according to claim 6, wherein said one or more corona discharge points are directed away from the filter medium.
8. Air purification device according to any one of claims 6 and 7, wherein the emitter
- 30 electrode is an elongated structure and said plurality of coronal discharge points are distributed along a length of the emitter electrode.

9. Air purification device according to any one of claims 1-8, wherein the emitter unit further comprises an emitter carrier for holding the emitter electrode and for electrically isolating the emitter electrode from the filter medium comprising the conductive material.

5

10. Air purification device according to any one of claims 1-9, wherein the emitter unit is flexibly connected to the filter medium so as to allow for deformation of the filter medium whilst the emitter unit being attached to the filter medium.

10 11. Air purification device according to any one of claims 1-10, further comprising:  
a power supply,  
a first connector connecting the power supply to the emitter electrode; and  
a second connector connecting the power supply to the filter medium comprising the conductive material.

1/6

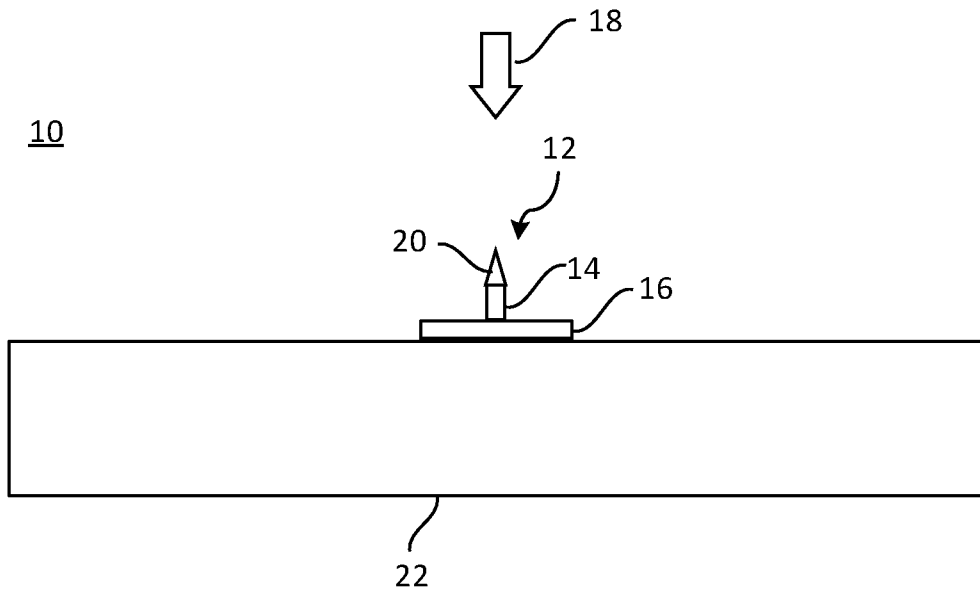

Fig. 1a

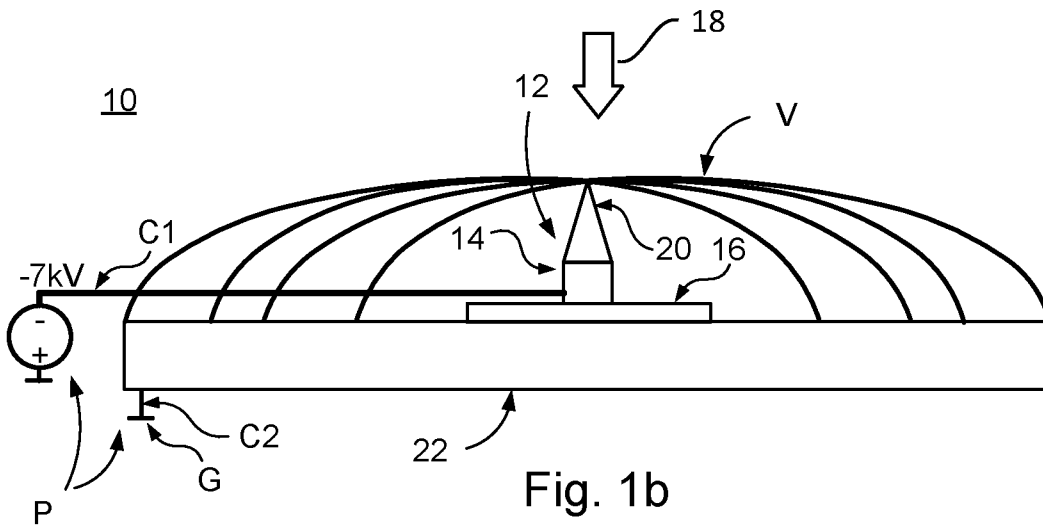

Fig. 1b

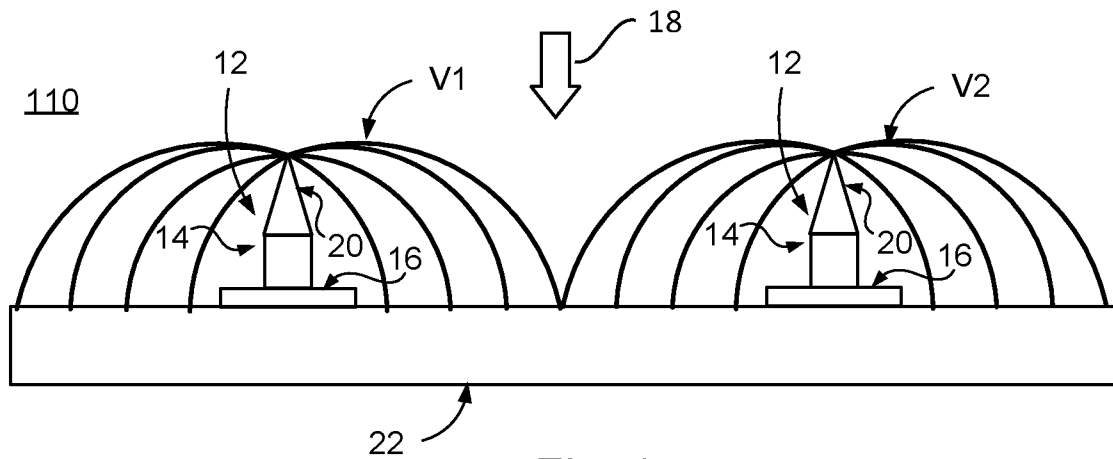

Fig. 1c

2/6

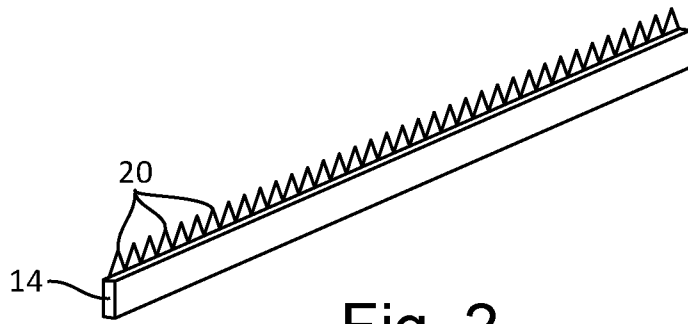

Fig. 2



Fig. 3

3/6

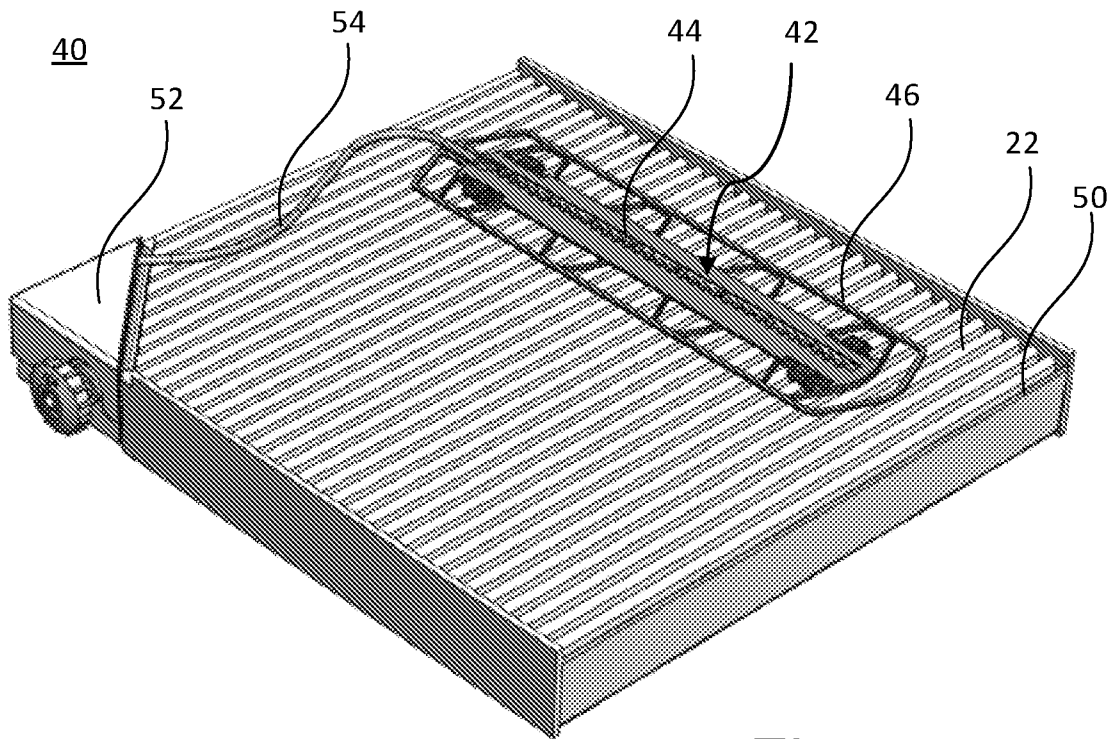

Fig. 4a

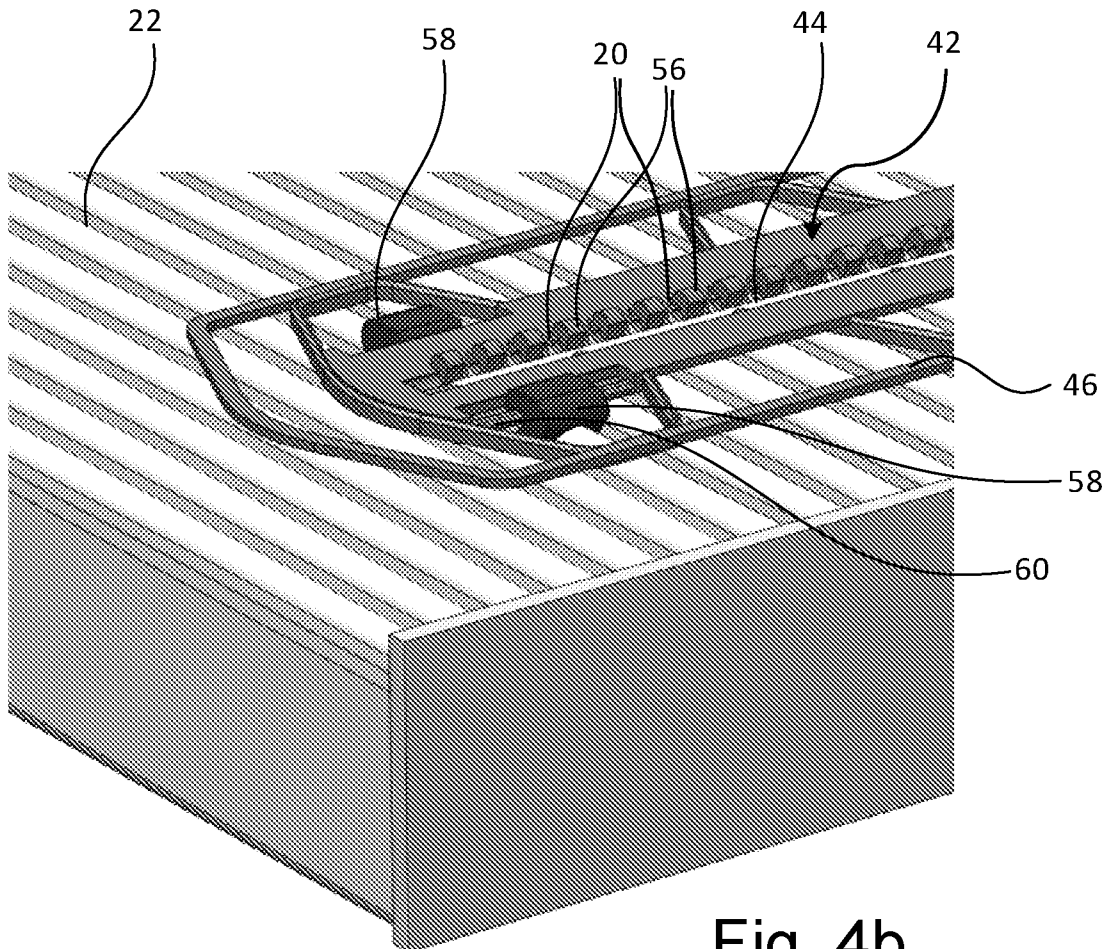

Fig. 4b

4/6

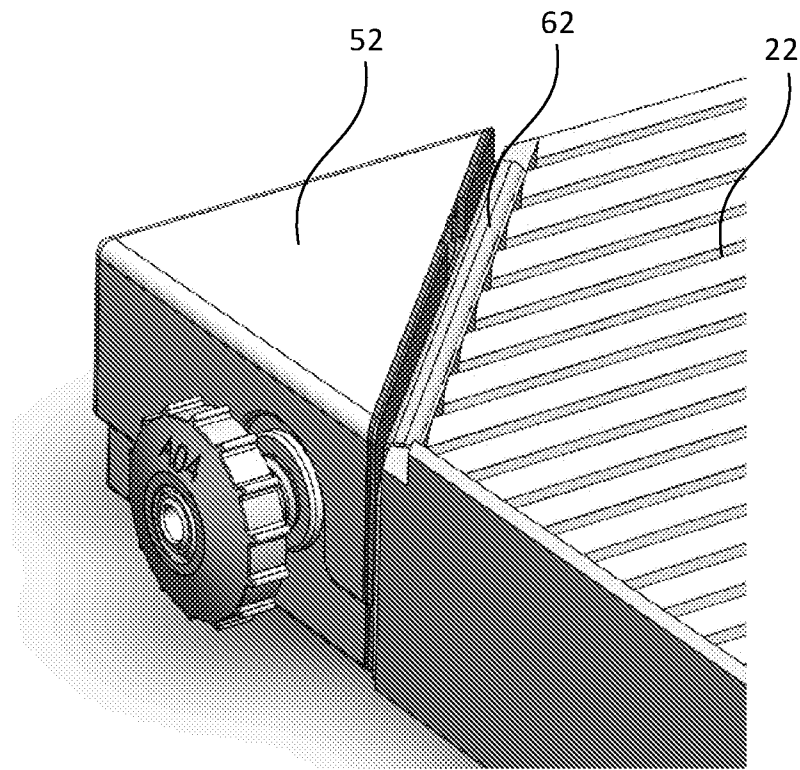

Fig. 4c

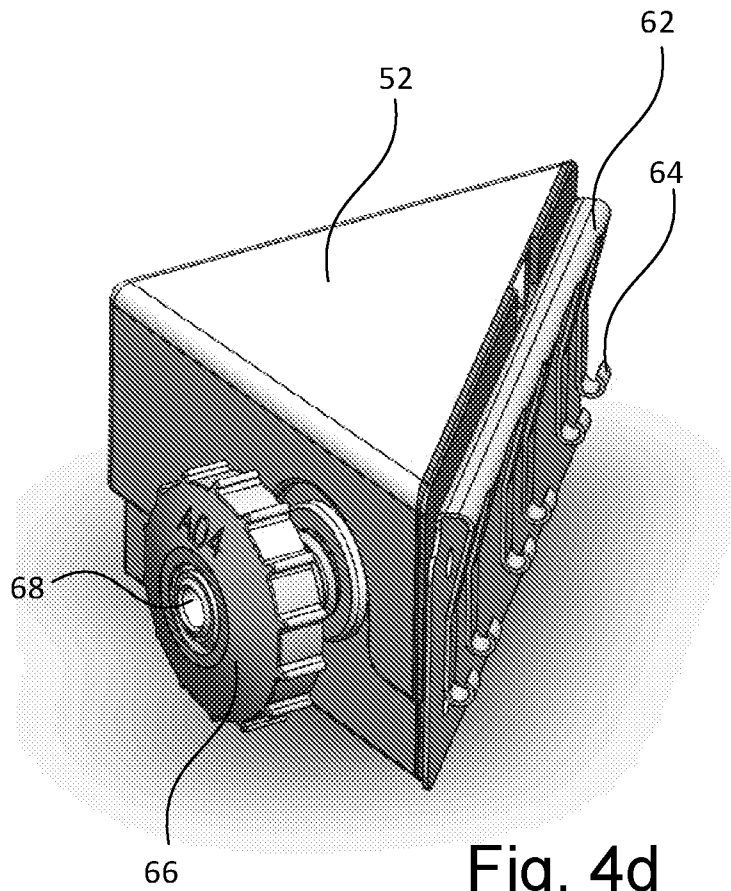

Fig. 4d

5/6

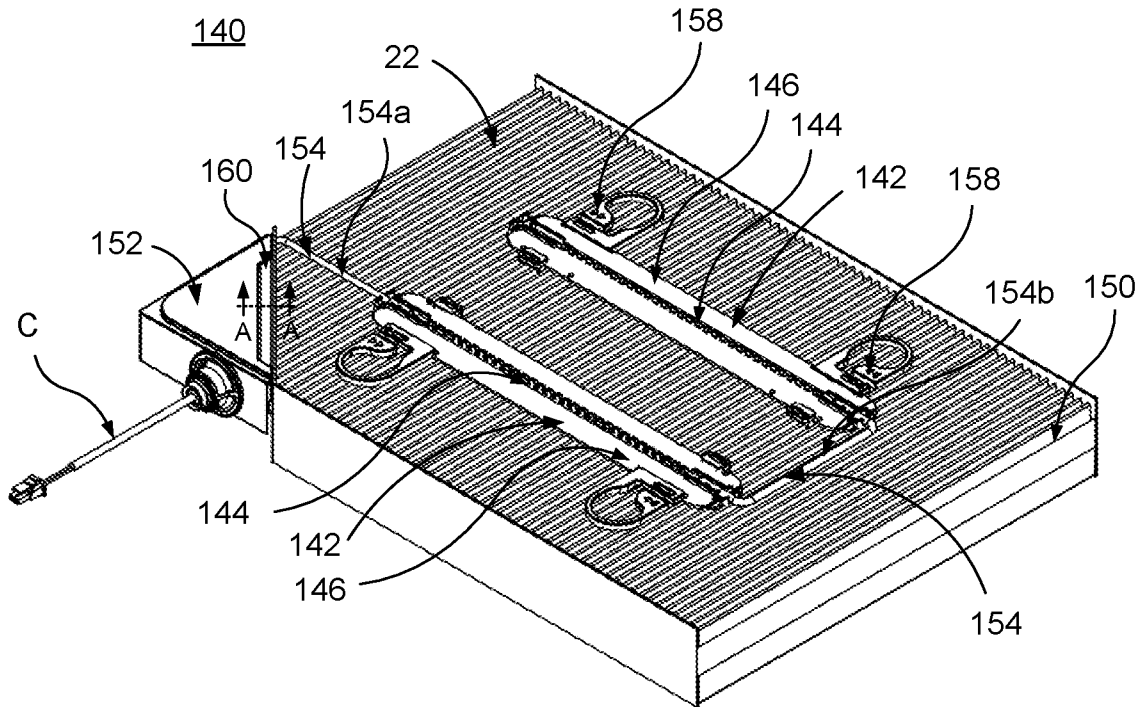

Fig. 5

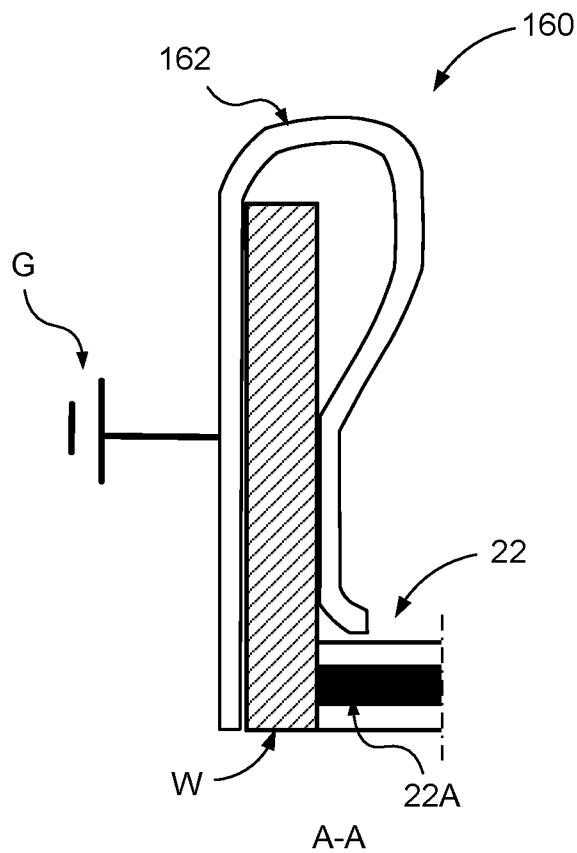

Fig. 6

6/6

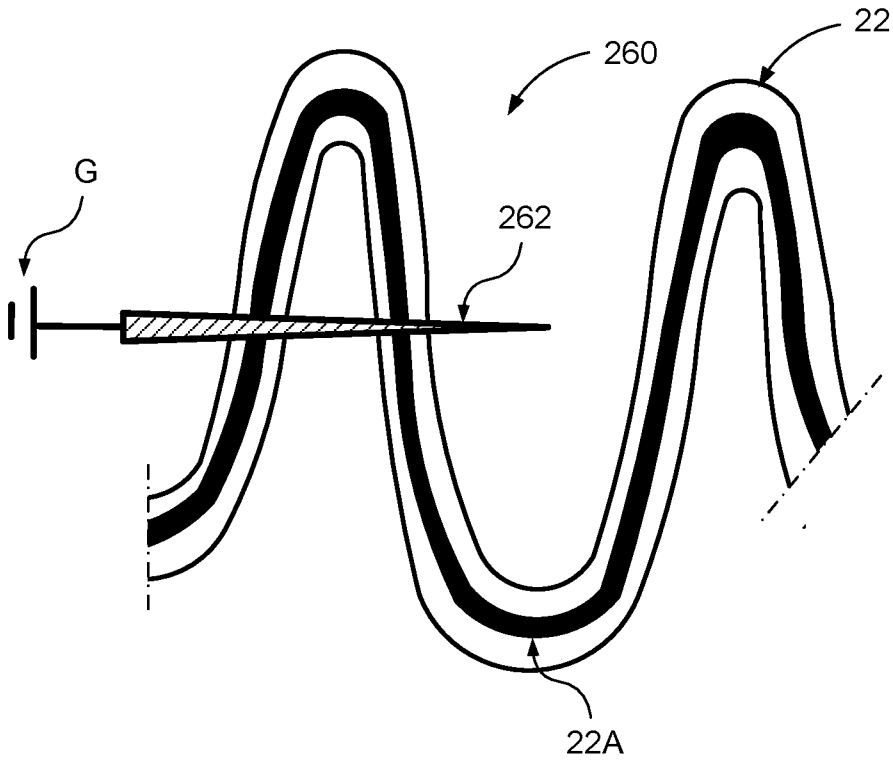

Fig. 7

## INTERNATIONAL SEARCH REPORT

International application No.  
PCT/SE2020/050672

A. CLASSIFICATION OF SUBJECT MATTER		
IPC: see extra sheet		
According to International Patent Classification (IPC) or to both national classification and IPC		
B. FIELDS SEARCHED		
Minimum documentation searched (classification system followed by classification symbols)		
IPC: B03C, F24F, H01T		
Documentation searched other than minimum documentation to the extent that such documents are included in the fields searched		
SE, DK, FI, NO classes as above		
Electronic data base consulted during the international search (name of data base and, where practicable, search terms used)		
EPO-Internal, PAJ, WPI data		
C. DOCUMENTS CONSIDERED TO BE RELEVANT		
Category*	Citation of document, with indication, where appropriate, of the relevant passages	Relevant to claim No.
X	EP 3488933 A1 (KRZYSZTOF CWIK PRO VENT SYSTEMY WENTYLACYJNE), 29 May 2019 (2019-05-29); abstract; paragraphs [0013]-[0014], [0031], [0036]-[0041], [0057]-[0059], [0066]-[0067]; figure 1; all claims --	1-11
X	FI 125997 B (TEKNOLOGIAN TUTKIMUSKESKUS VTT OY), 13 May 2016 (2016-05-13); page 8, line 15 - line 28; page 13, line 21 - line 25; page 3, line 4 - line 15; page 9, line 6 - line 8; page 5, line 7 - line 15; page 5, line 22 - line 28; figures 1,4A-4B --	1-11
<input checked="" type="checkbox"/>	Further documents are listed in the continuation of Box C.	<input checked="" type="checkbox"/> See patent family annex.
* Special categories of cited documents:		
"A" document defining the general state of the art which is not considered to be of particular relevance		"T" later document published after the international filing date or priority date and not in conflict with the application but cited to understand the principle or theory underlying the invention
"D" document cited by the applicant in the international application		"X" document of particular relevance; the claimed invention cannot be considered novel or cannot be considered to involve an inventive step when the document is taken alone
"E" earlier application or patent but published on or after the international filing date		
"L" document which may throw doubts on priority claim(s) or which is cited to establish the publication date of another citation or other special reason (as specified)		"Y" document of particular relevance; the claimed invention cannot be considered to involve an inventive step when the document is combined with one or more other such documents, such combination being obvious to a person skilled in the art
"O" document referring to an oral disclosure, use, exhibition or other means		
"P" document published prior to the international filing date but later than the priority date claimed		"&" document member of the same patent family
Date of the actual completion of the international search 17-07-2020	Date of mailing of the international search report 17-07-2020	
Name and mailing address of the ISA/SE Patent- och registreringsverket Box 5055 S-102 42 STOCKHOLM Facsimile No. + 46 8 666 02 86	Authorized officer Svetlana Borodulina Telephone No. + 46 8 782 28 00	

## INTERNATIONAL SEARCH REPORT

International application No.  
PCT/SE2020/050672

C (Continuation). DOCUMENTS CONSIDERED TO BE RELEVANT		
Category*	Citation of document, with indication, where appropriate, of the relevant passages	Relevant to claim No.
X	US 20080034973 A1 (GRIFFITHS GEORGE ET AL), 14 February 2008 (2008-02-14); abstract; paragraphs [0025]-[0029], [0035], [0044]-[0047]; figures 1,2,5,6; claims 1,5,8,11-17 --	1-11
X	US 20190143339 A1 (HOSOMI SATOHIKO), 16 May 2019 (2019-05-16); paragraphs [0031], [0035]-[0040], [0046]-[0049]; figures 1-3,8-10 --	1-11
X	CN 108480050 A (BEIJING DONGFANG MEASUREMENT & TEST INST), 4 September 2018 (2018-09-04); (abstract) Retrieved from: EPODOC database; Original document: figure 1 --	1-11
A	US 20170120255 A1 (CHO KWANG WOON ET AL), 4 May 2017 (2017-05-04); figures 1, 4 -- -----	1-11

Continuation of: second sheet

**International Patent Classification (IPC)**

**B03C 3/12** (2006.01)

**B03C 3/019** (2006.01)

**B03C 3/41** (2006.01)

**B03C 3/47** (2006.01)

**H01T 19/04** (2006.01)

**H01T 23/00** (2006.01)

**F24F 3/16** (2006.01)

## INTERNATIONAL SEARCH REPORT

Information on patent family members

International application No.

PCT/SE2020/050672

EP	3488933 A1	29/05/2019	PL	423617 A1	03/06/2019
			US	20190160475 A1	30/05/2019
FI	125997 B	13/05/2016	NONE		
US	20080034973 A1	14/02/2008	AT	450312 T	15/12/2009
			CA	2563867 A1	03/11/2005
			CN	1980744 A	13/06/2007
			DE	602005018033 D1	14/01/2010
			EP	1740310 B1	02/12/2009
			JP	2007533445 A	22/11/2007
			US	7655076 B2	02/02/2010
			WO	2005102534 A1	03/11/2005
US	20190143339 A1	16/05/2019	CN	109153024 A	04/01/2019
			JP	WO2017212688 A1	22/03/2019
			WO	2017212688 A1	14/12/2017
CN	108480050 A	04/09/2018	NONE		
US	20170120255 A1	04/05/2017	CN	106622662 A	10/05/2017
			KR	20170051893 A	12/05/2017
			US	10369576 B2	06/08/2019