

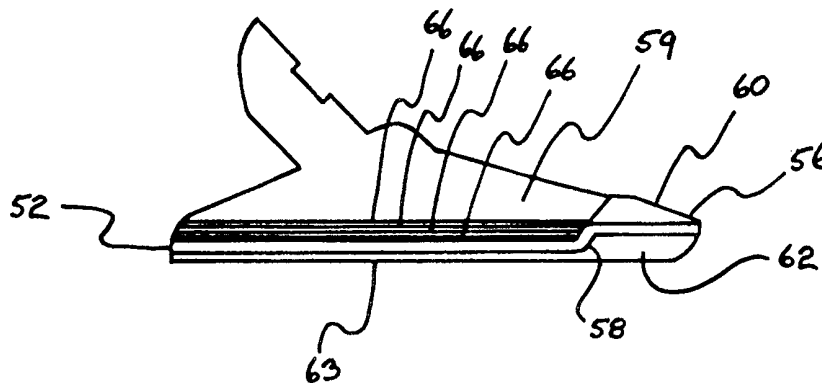

INTERNATIONAL APPLICATION PUBLISHED UNDER THE PATENT COOPERATION TREATY (PCT)

<p>(51) International Patent Classification ⁶ : A01B 15/04, 15/16</p>	<p>A1</p>	<p>(11) International Publication Number: WO 00/00005 (43) International Publication Date: 6 January 2000 (06.01.00)</p>
<p>(21) International Application Number: PCT/AU99/00517 (22) International Filing Date: 25 June 1999 (25.06.99) (30) Priority Data: PP 4361 26 June 1998 (26.06.98) AU (71) Applicant (for all designated States except US): MULTI-CROFT CORPORATION PTY. LTD. [AU/AU]; Level 13, 10 Queens Road, Melbourne, VIC 3004 (AU). (72) Inventor; and (75) Inventor/Applicant (for US only): BEYER, John [AU/AU]; 10 Carinya Road, Vermont, VIC 3133 (AU). (74) Agent: MORCOM, Norman, Bruce; 5a Hartnett Close, Mulgrave, VIC 3170 (AU).</p>		<p>(81) Designated States: AE, AL, AM, AT, AU, AZ, BA, BB, BG, BR, BY, CA, CH, CN, CU, CZ, DE, DK, EE, ES, FI, GB, GD, GE, GH, GM, HR, HU, ID, IL, IN, IS, JP, KE, KG, KP, KR, KZ, LC, LK, LR, LS, LT, LU, LV, MD, MG, MK, MN, MW, MX, NO, NZ, PL, PT, RO, RU, SD, SE, SG, SI, SK, SL, TJ, TM, TR, TT, UA, UG, US, UZ, VN, YU, ZA, ZW, ARIPO patent (GH, GM, KE, LS, MW, SD, SL, SZ, UG, ZW), Eurasian patent (AM, AZ, BY, KG, KZ, MD, RU, TJ, TM), European patent (AT, BE, CH, CY, DE, DK, ES, FI, FR, GB, GR, IE, IT, LU, MC, NL, PT, SE), OAPI patent (BF, BJ, CF, CG, CI, CM, GA, GN, GW, ML, MR, NE, SN, TD, TG).</p> <p>Published With international search report.</p>

(54) Title: WEAR RESISTANT GROUND WORKING IMPLEMENT



(57) Abstract

A ground working implement formed from a hard substrate material such as steel has a forward facing ground cutting edge. A wear resistant coating (59, 63) such as polyurethane is applied to at least one face of the implement. The coating adjacent the cutting edge may have a cut (66), trench or line of weakness formed in it substantially parallel to the cutting edge. The implement may be a cultivator tillage point having a generally triangular shaped working portion with a nose (56) and a pair of wings swept back therefrom, with the leading edge of the nose and wings forming a cutting edge. The metal at the rear of the nose portion is stepped (58) in order to protect the leading edge of the plastics material immediately behind the nose.

FOR THE PURPOSES OF INFORMATION ONLY

Codes used to identify States party to the PCT on the front pages of pamphlets publishing international applications under the PCT.

AL	Albania	ES	Spain	LS	Lesotho	SI	Slovenia
AM	Armenia	FI	Finland	LT	Lithuania	SK	Slovakia
AT	Austria	FR	France	LU	Luxembourg	SN	Senegal
AU	Australia	GA	Gabon	LV	Latvia	SZ	Swaziland
AZ	Azerbaijan	GB	United Kingdom	MC	Monaco	TD	Chad
BA	Bosnia and Herzegovina	GE	Georgia	MD	Republic of Moldova	TG	Togo
BB	Barbados	GH	Ghana	MG	Madagascar	TJ	Tajikistan
BE	Belgium	GN	Guinea	MK	The former Yugoslav Republic of Macedonia	TM	Turkmenistan
BF	Burkina Faso	GR	Greece			TR	Turkey
BG	Bulgaria	HU	Hungary	ML	Mali	TT	Trinidad and Tobago
BJ	Benin	IE	Ireland	MN	Mongolia	UA	Ukraine
BR	Brazil	IL	Israel	MR	Mauritania	UG	Uganda
BY	Belarus	IS	Iceland	MW	Malawi	US	United States of America
CA	Canada	IT	Italy	MX	Mexico	UZ	Uzbekistan
CF	Central African Republic	JP	Japan	NE	Niger	VN	Viet Nam
CG	Congo	KE	Kenya	NL	Netherlands	YU	Yugoslavia
CH	Switzerland	KG	Kyrgyzstan	NO	Norway	ZW	Zimbabwe
CI	Côte d'Ivoire	KP	Democratic People's Republic of Korea	NZ	New Zealand		
CM	Cameroon			PL	Poland		
CN	China	KR	Republic of Korea	PT	Portugal		
CU	Cuba	KZ	Kazakstan	RO	Romania		
CZ	Czech Republic	LC	Saint Lucia	RU	Russian Federation		
DE	Germany	LI	Liechtenstein	SD	Sudan		
DK	Denmark	LK	Sri Lanka	SE	Sweden		
EE	Estonia	LR	Liberia	SG	Singapore		

WEAR RESISTANT GROUND WORKING IMPLEMENT

5 **BACKGROUND AND SUMMARY OF THE INVENTION**

This invention concerns the provision of wear resistant surfaces on ground working implements. It has particular but not exclusive application to wear-prone ground-engaging components used on agricultural cultivator components, such as tillage
10 points plough shares, plough discs and the like, and on mining and earth-moving equipment.

This specification uses the term "tillage point" in its meaning as a general term which includes the type of agricultural tips or points used for scarifiers, sweeps, ground
15 busters, seeder combines, direct drills and the like.

Farmers often routinely modify presently available tillage points by, for example, laying on hard facing materials from welding rods, or by welding onto the points additional metal such as stainless steel bolts. Longer tip life may be achieved but
20 usually at the cost of significantly higher fuel consumption from the machinery pulling the modified points.

Great effort has been expended by many people in recent decades to develop harder and tougher steels and other materials for the manufacture of ground working
25 implements such as the replaceable tips intended to engage and work the ground when mounted on agricultural and earth moving machines. It is known for such implements to have been constructed entirely of such newly developed alloys and systems have been developed for bonding inserts, such as tungsten carbide strips, or coatings of such harder materials onto the wearing edges. However such sophisticated alloys are
30 relatively expensive, and hard inserts such as tungsten carbide have a tendency to fracture when cultivating ground containing rocks.

In the case of the common arrowhead shaped tillage points used on agricultural equipment, prior art developments have concentrated on protecting the upper surface of the leading edge of the point. An example of this type of development can be seen
5 in patent specification AU-A-74010/91.

It is not only harder materials that have been proposed for this purpose. Patent specification WO 97/14291 describes how a point for an agricultural scarifier may be constructed with a polyurethane material applied to its outer surface in order to reduce
10 wear of the scarifier point. The point has a core plate having a series of protrusions, indentations and holes formed in it and these help prevent separation of the protective polyurethane coating from the core plate during use.

It has now been observed that points made in accordance with the above patent
15 specification WO 97/14291 can have a tendency for the polyurethane to delaminate from the steel substrate, particularly after the steel has partially worn away and particularly on the upper surface of the point. The present invention is directed to an alternative configuration whereby the likelihood of such delamination is greatly reduced.

20 Accordingly, in one aspect the invention provides a ground working implement having a cutting edge, said implement being formed from a rigid body of substrate material and a wear resistant coating applied to a face of the body up to the cutting edge, the coating adjacent the cutting edge having a cut, a trench or a line of weakness
25 formed therein substantially parallel to the edge. Preferably the coating adjacent the cutting edge has a series of parallel cuts, trenches or lines of weakness formed therein substantially parallel to the edge. Preferably the coating is softer and more flexible than the substrate material and is preferably a polyurethane based plastics material. The implement may have a mounting portion by which the implement is adapted to be
30 attached to an agricultural ground working implement and have a generally triangular shaped working portion comprising a nose portion and a pair of wings swept back therefrom, with the leading edge of the nose and wings forming said cutting edge.

In another aspect the invention provides a tillage point constructed as a metal body with wear resistant plastics material affixed thereto, said tillage point having a mounting portion by which it is adapted to be attached to an agricultural ground working implement and having a generally triangular shaped working portion comprising a nose portion and a pair of wings swept back therefrom, with the leading edge of the nose and wings forming a cutting edge and the metal at the rear of the nose portion stepped in order to protect the leading edge of the plastics material immediately behind the nose. Preferably the metal body is formed from sheet metal and, when aligned as for use, has the nose portion upwardly displaced to create said step. Preferably the upper surface of the nose does not carry a wear resistant covering of plastics material. Preferably a pad of wear resistant material fills the underside of the nose portion.

The wear resistant plastics material may be a polyurethane material bonded to the metal body in an injection moulding operation wherein the metal body is placed within the injection moulding die.

BRIEF DESCRIPTION OF THE DRAWINGS

Examples of the invention will now be described with reference to the attached drawings where:

Figure 1 is a side view of a prior art tillage point.

Figure 2 is an underside perspective view of the point in Figure 1.

Figure 3 is a similar view to that shown in Figure 2 but with the point partly worn.

Figure 4 is a plan view showing the partly worn tillage point of Figure 3.

Figure 5 is a side view of a point according to one embodiment of the present invention.

Figure 6 is a side view showing the pressed metal body of a point according to another embodiment of the present invention.

Figure 7 is a side view of the body in Figure 6 following the affixing of wear resistant polyurethane to complete manufacture of the point.

Figure 8 is a plan view looking down upon the point shown in Figure 7.

DETAILED DESCRIPTION OF THE PREFERRED EMBODIMENTS

5 Referring to Figures 1 and 2, the tillage point 10 has a mounting portion 12 extending upwards and rearwards which has a hole 13 for fastening the point to a scarifier (not shown). The mounting portion 12 is integrally formed with a working portion 14 of the point 10. The working portion 14 has a nose portion 16 at its front extremity and wings 20 extending laterally. The general plane of each wing 20 is angled relative to
10 the other so that a rounded ridge 27 runs centrally along the upper surface from the mounting portion 12 to the nose portion. The leading edge of the tillage point 10, extending from the nose 16 down the front of both wings 20 is the cutting edge 22 and this is the edge which is pushed into the ground being cultivated. The top face of the working portion 14 is covered with polyurethane.

15 Referring to Figures 3 & 4, the point illustrated has deteriorated in such a manner that its metal body 26 has worn back further on its cutting edge 32 than has the overlying covering 28 of polyurethane on the top of the working portion of the point. At the nose a flap 34 of polyurethane protrudes over and beyond the worn metal, and at the
20 regions 30 and 31 on the wings the polyurethane also protrudes forwards of the metal. Such overhang of the polyurethane covering makes it susceptible to be dragged upwards and backwards when the point is in use and such displacement of the covering substantially accelerates the rate of wear of the point and increases the ground penetration resistance of the point, increasing fuel consumption by the tractor
25 pulling the scarifier.

In Figure 4, at a region 30 on the cutting edge of one of the wings a loose portion 38 of the polyurethane has been bent upwards much like the flap 34 at the nose. On the cutting edge of the other wing, at a region 31 a portion 40 of polyurethane has
30 separated from the underlying metal and has filled with soil which has been compacted into the crevice so created. The continued forcing of soil into such crevices, and the increased drag on the covering as it is forced away from the metal by

the soil pushing into the crevices, can rapidly cause the covering on the top of the working portion of the tillage point to peel off in a single sheet. With the protective covering gone the metal wears much more quickly.

5 With reference to the embodiment of the present invention shown in Figure 5, the point illustrated is substantially the same as that in Figure 1 except that the polyurethane has a series of parallel thin slits 45 in it, through its full thickness, close to the cutting edge. By means of these slits, the overlying polyurethane is able to break away from the cutting edge in thin strips before it overhangs significantly, while
10 still performing its wear resisting function up until that time.

As an alternative to the preferred arrangement of the slits passing through the full thickness of the covering as described above, they may be formed to pass only part way through the thickness of polyurethane, so leaving a weakened attachment which
15 can readily be torn when the tillage point has worn by the appropriate amount. As a further alternative the slits may be replaced by narrow trenches which may pass fully or partially through the polyurethane. Yet another alternative would be for each slit or trench to be discontinuous along its length and this may take the form of a series of short slits like a dashed line, or a row of small holes, or any other line of weakness.

20

Figures 6 to 8 serve to illustrate another embodiment of the invention. With reference to Figure 6, the metal body 52 of the tillage point is formed by pressing sheet metal into an appropriate form. The general shape is the same as that described with reference to Figure 5, but in the body 52 the nose portion 56 is displaced upwards relative to its adjacent portions (including the wings) of the body to form a step 58.
25 The displacement, and thus the height of the step, is about the thickness of the metal body. The nose portion 56 has two triangular planar segments, only one 57 of which is visible in Figure 6, which join at a rounded central ridge which continues the line of the rounded ridge 54 on the remainder of the point towards the mounting portion 53.

30

As best seen in Figure 7 the polyurethane covering 59 which is then affixed to the upper surface of the working portion butts up against the step 58 so that the step

protects the leading edge of the covering at the nose. The polyurethane does not cover the top face 60 of the nose which is left as exposed metal. The underside of the wings 49 and 50 are also covered in a polyurethane layer 63 and the underside of the nose is filled with a pad 62 of polyurethane bonded to the metal body. The pad 62 is thus thicker than the polyurethane layer 63 under the wings, and the increased thickness is the height of the step 58.

Alternatively the polyurethane pad 62 may be replaced by an insert of appropriately hardened and toughened steel or other wear resisting material, and if this option is adopted, the hard insert would provide a downward step behind which the leading edge of layer 63 would be protected in a similar manner to the protection offered to the upper layer 59 by the upward step 59.

On each of the wings 49 and 50, the polyurethane bonded onto the upper surface of the wings carries four slits 66 through its thickness close to and parallel to the cutting edge to serve the purpose as discussed above in relation to Figure 5.

The polyurethane is of a form suited to injection moulding and is preferably bonded to the steel body of the tillage point by firstly appropriately cleaning and priming the body and then introducing it into an appropriately shaped mould of an injection moulding machine. Reacting polyurethane is then introduced into the mould, where it is shaped and held against the body 52 where required, and cured in the mould.

As noted above, the polyurethane is preferably not intended to cover the top face 60 of the nose which is instead left as exposed metal. Nevertheless we have found from extensive testing that it is common when producing tillage points of the form described with reference to Figures 6 to 8, when injection moulding the polyurethane into contact with the metal body, to have the reaction mixture wet the top face of the nose due to a less than perfect seal around it. This results in a thin film or flash of the reacted mixture adhering to the top face 60 of the nose. This film can be extremely thin to the point where it shows only as a faint bloom on the surface of the nose. Due to its extreme thinness, such a film does not have any significant effect on the

abrasion resistance provided and the top face 60 of the nose so covered should not be considered to have a wear resistant polyurethane coating thereon within the context of this invention.

- 5 The metal from which the metal body is pressed is conveniently steel sheet of from 2mm to 12mm thick, depending on the span of the wings of the tillage point and the type of ground being tilled. The thickness of the coating is conveniently about the same as that of the steel. However the thickness of the pad 62 would be greater, as discussed above.

10

The wear resistant covering used in the present invention may be any suitable material but is preferably selected from the range of wear resistant polyurethanes widely supplied and known by the skilled person. It is preferably a thermoplastic urethane suitable for injection moulding applications and sold under the name Teton 90 by
15 Urethane Compounds Pty Ltd in Australia. Use of a Chemloc (trade mark) primer from Lord Chemicals is also preferred in order to increase the bond between the polyurethane and steel substrate.

Throughout this specification, unless the context requires otherwise, the word
20 "comprise", and variations such as "comprises" and "comprising", will be understood to imply the inclusion of a stated integer or group of integers but not the exclusion of any other integer or group of integers.

Finally, it is to be understood that various alterations, modifications and/or additions
25 may be introduced into the constructions and arrangements of parts previously described without departing from the spirit or ambit of the invention. For example, although the tillage points illustrated in the Figures are all mounted to their relevant agricultural machines by way of a bolt or the like through the hole 13 in the mounting portion of the point, other mounting systems may be used. Suitable alternatives
30 include the tapered knock-on and knock-off configurations widely used by some manufacturers of agricultural machinery.

CLAIMS

1. A ground working implement having a cutting edge, said implement being formed from a rigid body of substrate material and a wear resistant coating applied to a face of the body up to the cutting edge, the coating adjacent the cutting edge having a cut, a trench or a line of weakness formed therein substantially parallel to the edge.
5
2. An implement according to claim 1 wherein the coating adjacent the cutting edge has a series of parallel cuts, trenches or lines of weakness formed therein substantially parallel to the edge.
10
3. An implement according to claim 1 or 2 wherein the coating is softer and more flexible than the substrate material.
- 15 4. An implement according to any one of claims 1 to 3 wherein the coating is a polyurethane based plastics material.
5. An implement according to any one of claims 1 to 4 and having a mounting portion by which the implement is adapted to be attached to an agricultural ground working implement and having a generally triangular shaped working portion comprising a nose portion and a pair of wings swept back therefrom, with the leading edge of the nose and wings forming said cutting edge.
20
6. A tillage point constructed as a metal body with wear resistant plastics material affixed thereto, said tillage point having a mounting portion by which it is adapted to be attached to an agricultural ground working implement and having a generally triangular shaped working portion comprising a nose portion and a pair of wings swept back therefrom, with the leading edge of the nose and wings forming a cutting edge and the metal at the rear of the nose portion stepped in order to protect the leading edge of the plastics material immediately behind the nose.
30

7. A tillage point according to claim 6 wherein the metal body is formed from sheet metal and, when aligned as for use, has the nose portion upwardly displaced to create said step.
- 5 8. A tillage point according to claim 6 or 7 wherein the upper surface of the nose does not carry a wear resistant covering of plastics material.
9. A tillage point according to any one of claims 6 to 8 wherein a pad of wear resistant material fills the underside of the nose portion.
- 10 10. A tillage point according to any one of claims 6 to 9 wherein the wear resistant plastics material is a polyurethane material bonded to the metal body in an injection moulding operation wherein the metal body is placed within the injection moulding die.

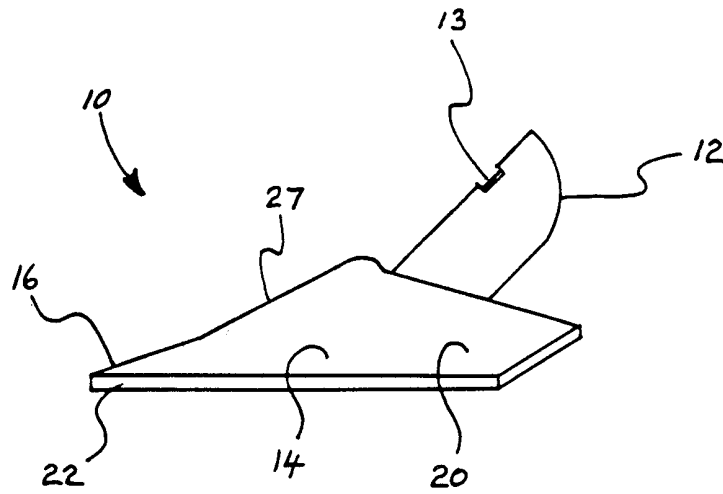

Fig. 1

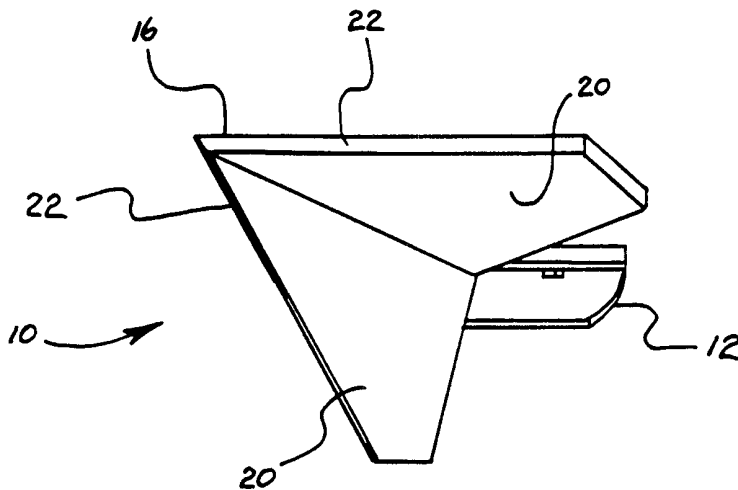

Fig. 2

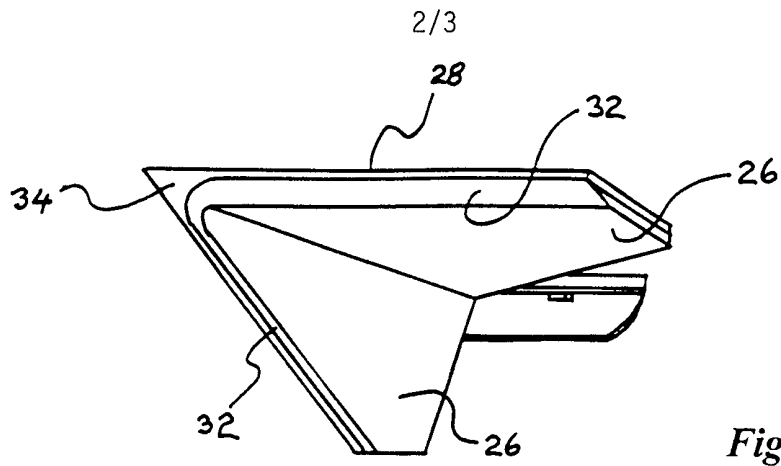

Fig. 3

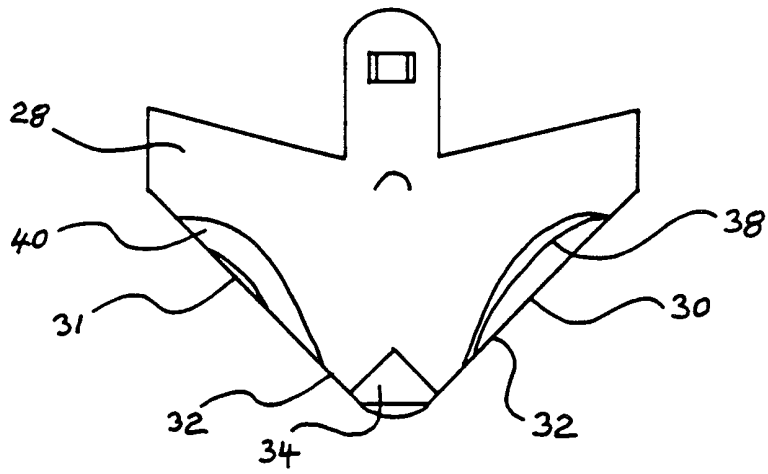

Fig. 4

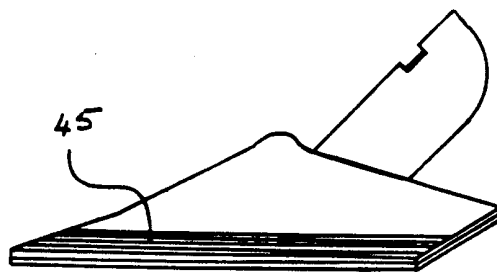

Fig. 5

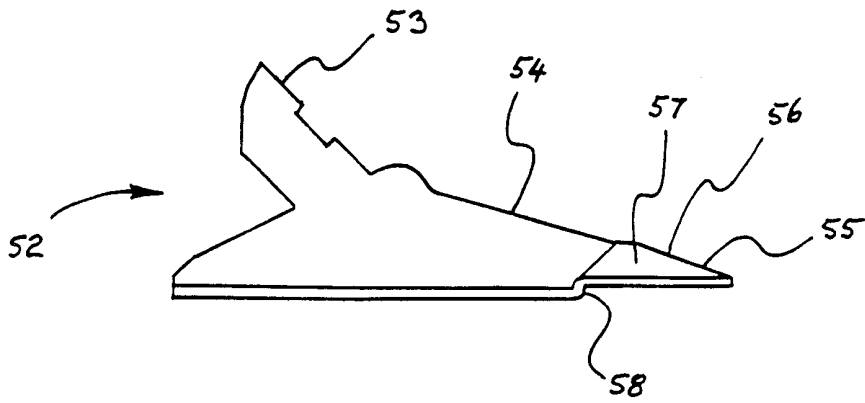

Fig. 6

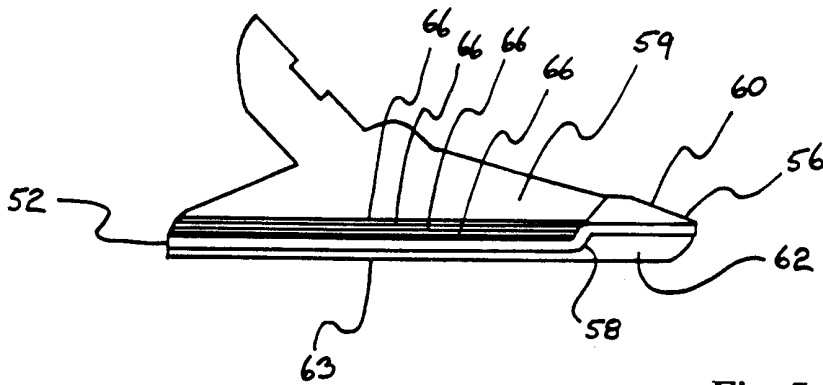

Fig. 7

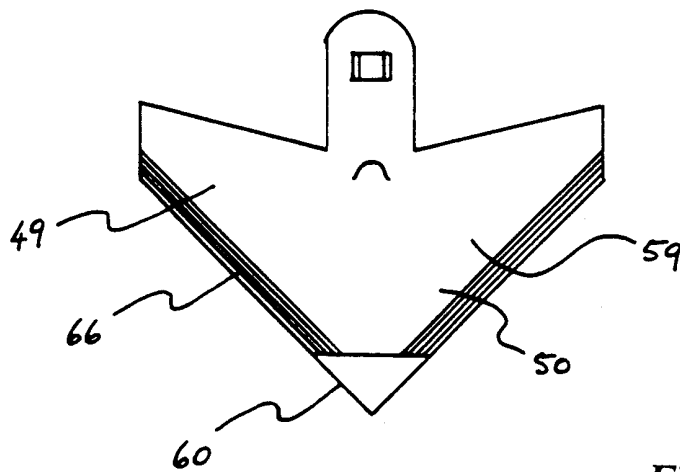

Fig. 8

INTERNATIONAL SEARCH REPORT

International application No.
PCT/AU 99/00517

A. CLASSIFICATION OF SUBJECT MATTER		
Int Cl ⁶ : A01B 15/04, 15/16		
According to International Patent Classification (IPC) or to both national classification and IPC		
B. FIELDS SEARCHED		
Minimum documentation searched (classification system followed by classification symbols) IPC: A01B 15/04, 15/16		
Documentation searched other than minimum documentation to the extent that such documents are included in the fields searched		
Electronic data base consulted during the international search (name of data base and, where practicable, search terms used) WPAT: A01B/IC & E02F 009/IC + WEAR:/ABRAS:/ABRAD: AND RESIST:/PREVENT:		
C. DOCUMENTS CONSIDERED TO BE RELEVANT		
Category*	Citation of document, with indication, where appropriate, of the relevant passages	Relevant to claim No.
A	WO 97/14291 A (NORTECH CORPORATION PTY LTD et al.) 24 April 1997	
A	US 5148660 A (EDWARD) 22 September 1992	
A	AU 74010/91 A (CLAREWOOD PTY LTD et al) 3 October 1991	
<input checked="" type="checkbox"/> Further documents are listed in the continuation of Box C <input checked="" type="checkbox"/> See patent family annex		
* Special categories of cited documents: "A" document defining the general state of the art which is not considered to be of particular relevance "E" earlier application or patent but published on or after the international filing date "L" document which may throw doubts on priority claim(s) or which is cited to establish the publication date of another citation or other special reason (as specified) "O" document referring to an oral disclosure, use, exhibition or other means "P" document published prior to the international filing date but later than the priority date claimed	"T" later document published after the international filing date or priority date and not in conflict with the application but cited to understand the principle or theory underlying the invention "X" document of particular relevance; the claimed invention cannot be considered novel or cannot be considered to involve an inventive step when the document is taken alone "Y" document of particular relevance; the claimed invention cannot be considered to involve an inventive step when the document is combined with one or more other such documents, such combination being obvious to a person skilled in the art "&" document member of the same patent family	
Date of the actual completion of the international search 2 August 1999		Date of mailing of the international search report 10 AUG 1999
Name and mailing address of the ISA/AU AUSTRALIAN PATENT OFFICE PO BOX 200 WODEN ACT 2606 AUSTRALIA Facsimile No.: (02) 6285 3929		Authorized officer R. SUBBARAYAN Telephone No.: (02) 6283 2377

INTERNATIONAL SEARCH REPORT

international application No.
PCT/AU 99/00517

C (Continuation). DOCUMENTS CONSIDERED TO BE RELEVANT		
Category*	Citation of document, with indication, where appropriate, of the relevant passages	Relevant to claim No.
A	FR 2679099 A1 (KIRSCH) 22 January 1993	

INTERNATIONAL SEARCH REPORT
Information on patent family members

International application No.
PCT/AU 99/00517

This Annex lists the known "A" publication level patent family members relating to the patent documents cited in the above-mentioned international search report. The Australian Patent Office is in no way liable for these particulars which are merely given for the purpose of information.

Patent Document Cited in Search Report		Patent Family Member	
WO	9714291	AU	72068/96

END OF ANNEX