

12 **EUROPEAN PATENT APPLICATION**

21 Application number: 83306564.2

51 Int. Cl.⁴: **E 04 B 5/04**
E 04 B 5/26, E 04 C 1/36

22 Date of filing: 28.10.83

43 Date of publication of application:
08.05.85 Bulletin 85/19

84 Designated Contracting States:
AT BE CH DE FR IT LI LU NL SE

71 Applicant: **Trent Concrete Floors Limited**
Hoveringham Nottinghamshire NG14 7JX(GB)

72 Inventor: **Sparrow, Ian Haugh**
24 Beckingthorpe Drive
Bottesford Nottinghamshire(GB)

74 Representative: **MacGregor, Gordon et al,**
ERIC POTTER & CLARKSON 14 Oxford Street
Nottingham, NG1 5BP(GB)

54 **Dry-laid floors.**

57 The floor is composed of parallel spaced beams (11) having flanges (12) and blocks (13) of polystyrene foam which are laid on the flanges to bridge the gaps between the beams. Boards (26) are laid on the polystyrene blocks, and are supported by the blocks, which form load-bearing members of the floor. The blocks may have flanged portions (14) extending over the beams, so as to provide heat insulation.

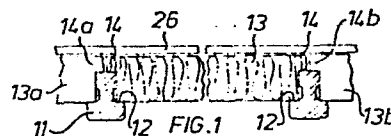

DRY-LAID FLOORS

This invention relates to a dry-laid floor, i.e. a floor of the type in which wet concrete or the like is not used for the basic supporting structure, but components are laid in a preformed state.

5 Dry-laid floors have been known for centuries and it is still common practice to lay wooden boards across joists to form such a floor.

Where a heavy load-bearing floor has been required, e.g. in factories, it has been common, however, to lay solid
10 floors using wet concrete.

In more recent years, suspended floors have been laid on concrete or steel beams. A reinforced concrete raft is often cast in situ on such beams by means of shuttering laid between the beams. An example of a floor of this type is
15 illustrated in U.K. Patent Specification No. 2053313. Parallel beams of inverted-T shape are provided and panels are laid between the beams, supported on the flanges defined by the cross-piece of the "T". Wet concrete is then laid on
20 the panels and on the beams and allowed to set. The ends of the panels adjacent the beams are bevelled to form a triangular section gap between each end of each panel and the adjacent upright wall of the corresponding beam. This gap fills with concrete to form concrete columns along the beams to support the concrete raft.

25 In this prior art patent specification, the panels, which form shuttering, are left in situ and are made of material with good heat insulating properties, foamed polystyrene being preferred. The foamed polystyrene supports the unset concrete during construction of the
30 floor, but has no supporting function in the completed floor. The set concrete shrinks away from the panels and the raft is wholly supported by the beams.

The contribution to the art provided by the published U.K. patent specification is an improvement in insulation
35 effected by providing foamed polystyrene insulating members

-2-

around the underside of the beams.

It is also common practice to provide dry-laid floors supported by beams. Slabs of concrete are dry-laid on the beams. Heat insulation in floors of this type has been
5 provided by means of sheets of foamed polystyrene laid on the slabs and beams, with a surface covering of wooden sheets. The wooden sheets spread the load, in use, and avoid local damage to the polystyrene layer. The polystyrene layer is thin and has no supporting function.

10 Foamed polystyrene is extensively used for insulating purposes in both dry-laid and wet-laid floors. It is always used purely for insulating purposes in the finished floor. The present inventor has now made the surprising discovery that it is possible to use foamed polystyrene members for
15 load-supporting purposes in a floor. This enables a dry-laid floor to be constructed without use of concrete slabs. The floor is, therefore, much lighter than conventional floors, much easier to lay and much cheaper and the supporting members also provide inherent excellent heat
20 insulation properties.

The present invention provides a dry-laid floor comprising parallel, spaced beams a multiplicity of foamed plastics members laid on the beams and an upper layer over the members, wherein the foamed plastics members are blocks,
25 which support the upper layer and serve as load bearing members of the floor. The foamed plastics blocks are preferably polystyrene blocks and the upper layer may comprise wooden boards.

The blocks may be laid on the top surfaces of the
30 beams, or the beams may have flanges below the top surfaces for supporting the blocks. In the latter case, the blocks also preferably have flanges which extend over the tops of the beams to form a continuous planar upper surface.

The distance between block support surfaces of adjacent
35 beams is, preferably, not more than 900 mm and, advantageously not more than 600 mm. The depth of each block above the support surface is, preferably, not less

than 80 mm and advantageously, not less than 100 mm.

The invention also resides in a method of constructing a dry-laid floor having parallel spaced beams, the method comprising laying foamed plastics blocks on the beams to
5 bridge the gaps between the beams so as to form load-bearing members. The blocks are preferably polystyrene blocks and may have wooden panels adhered to their upper surfaces, or otherwise, wooden panels are laid on the blocks.

Reference is now made to the accompanying drawings,
10 wherein :-

Figure 1 is a diagrammatic sectional view of part of a dry-laid floor according to the invention;

Figure 2 shows how an edge of the floor may be finished;

15 Figure 3 shows a modification of the finishing of the edge of the floor;

Figures 4 to 6 show modifications of the floor illustrated in Figure 1;

Figure 7 is a perspective view, partly in section, of a
20 part of a dry-laid floor according to the embodiment of Figure 1; and

Figure 8 is a diagrammatic sectional view of part of another embodiment of a dry-laid floor according to the invention.

25 Referring to Figures 1 & 7, the floor is shown to comprise parallel, spaced beams 11, only two being shown. The particular beams shown are made of reinforced concrete and are basically of inverted T shape, with the bars of the T defining flanges 12. Closed-cell foamed plastics blocks
30 13 are laid in alignment between the beams on the flanges 12, so as to bridge the gap between the beams. Each block 13 is a close fit between the beams. The blocks have no reinforcing elements or reinforcing fillers.

Each block has opposite edge flange portions 14 which
35 extend over part of the top of each beam 11. On the opposite side of each beam, other blocks 13a, 13b have flange portions 14a, 14b, which butt against the flange

-4-

portion 14 to define a continuous planar upper surface. Panels of wood 26 are laid on the blocks, with a thin plastics sheet between the wood and the blocks (not shown in Figure 1) to serve as a vapour check.

5 In this particular example, the distance between the flanges 12 is about 800 mm and the total width of each block, including the flange portions 14, about 900 mm. The depth of each block is about 140 mm, with about 40 mm above the top level of the beams.

10 At the edges of the floor, special edge blocks 20 of foamed plastics may be used (Figure 2). In these blocks, the flange portion 21, on one side, is extended to cover the whole of the end beam 11.

An alternative arrangement is shown in Figure 3, where 15 the flange portion is omitted at one side and the block 23 has a rebate 22 instead. The rebate, which effectively extends over the beam 11, may be filled with a foamed plastics panel (not shown).

Figure 4 illustrates a floor arrangement in which 20 flange portions are omitted entirely and the blocks 25 extend only to the tops of the beams 11. Foamed plastics sheets and wooden panels 26 are laid across the top surface defined by the beams and the blocks.

Figure 5 shows an alternative, similar to the 25 arrangement of Figure 1, but in which the block 30 extends to the bottoms of the beams 11. This defines a flat lower face 31, together with the bottoms of the beams, which may be finished to define a ceiling.

Figure 6 shows a similar modification of the 30 arrangement shown in Figure 4, the blocks 35 with the beams 11 defining flat top and bottom surfaces, 37, 38 respectively.

The blocks need not terminate flush with, or above the bottom surfaces of the beams, but may extend below the 35 beams.

It is also envisaged that instead of the blocks being covered with wood, a concrete or other screed may be laid on

the blocks.

The blocks of expanded foamed plastics are preferably composed of polystyrene, but other foamed plastics may be used, e.g. polyurethane.

5 The beams need not be flanged and may, for example consist of wood or steel, although prestressed or reinforced concrete is preferred. Figure 8 shows an alternative embodiment comprising beams 111 without flanges and having top surfaces 112. The blocks 113, 113a, and 113b, are laid
10 on the top surfaces with their end faces substantially in contact to define a thick continuous foamed plastics layer over the beams. An upper layer 126 is laid on the blocks.

15

20

25

30

35

CLAIMS

1. A dry-laid floor comprising parallel, spaced beams (11), a multiplicity of foamed plastics members (13, 13a, 13b) laid on the beams and an upper layer (26) above the members characterised in that the foamed plastics members are blocks
5 (13, 13a, 13b) which support the upper layer (26) and serve as load-bearing members of the floor.
2. A dry-laid floor according to Claim 1, wherein the blocks consist of foamed polystyrene.
3. A dry-laid floor according to Claim 1 or 2, wherein the
10 upper layer includes boards (26) laid on the blocks (13, 13a, 13b).
4. A dry-laid floor according to Claim 1, 2 or 3, wherein the beams (11) are constructed of reinforced or prestressed concrete.
- 15 5. A dry-laid floor according to any preceding claim, wherein the beams have flanges below their top surfaces, the blocks seating on the flanges and having upper flange portions (14, 14a, 14b) extending over the top surface of at least one of the adjacent beams (11) and arranged so that the
20 blocks form a continuous planar upper surface, on which the upper layer (26) is supported.
6. A dry-laid floor according to any preceding claim, wherein the distance between adjacent flanges of adjacent beams is not more than 900 mm.
- 25 7. A dry-laid floor according to Claim 5, wherein the said distance is not more than 600 mm.
8. A dry-laid floor according to any preceding claim, wherein the depth of each block above the flanges is not less than 80 mm.
- 30 9. A dry-laid floor according to Claim 7, wherein said depth is not less than 100 mm.
10. A method of producing a dry-laid floor, in which foamed plastics members (13) are laid on parallel beams (11) to bridge gaps between the beams, and an upper layer (26) is
35 provided over the members (13), characterised in that the

-7-

members are blocks (13, 13a, 13b) and the upper layer (26) is supported on the blocks, whereby the blocks define load bearing members of the floor.

5

10

15

20

25

30

35

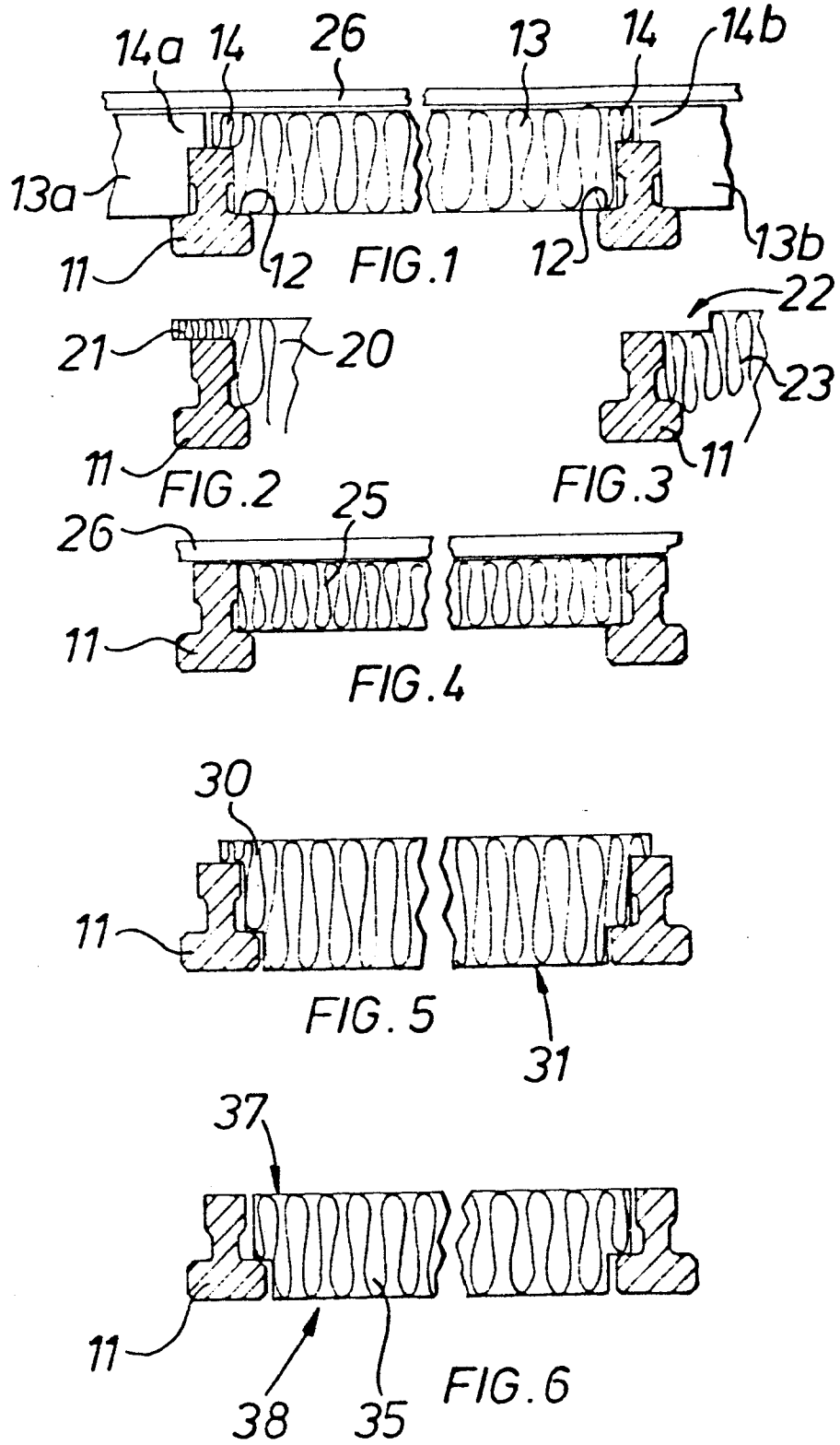

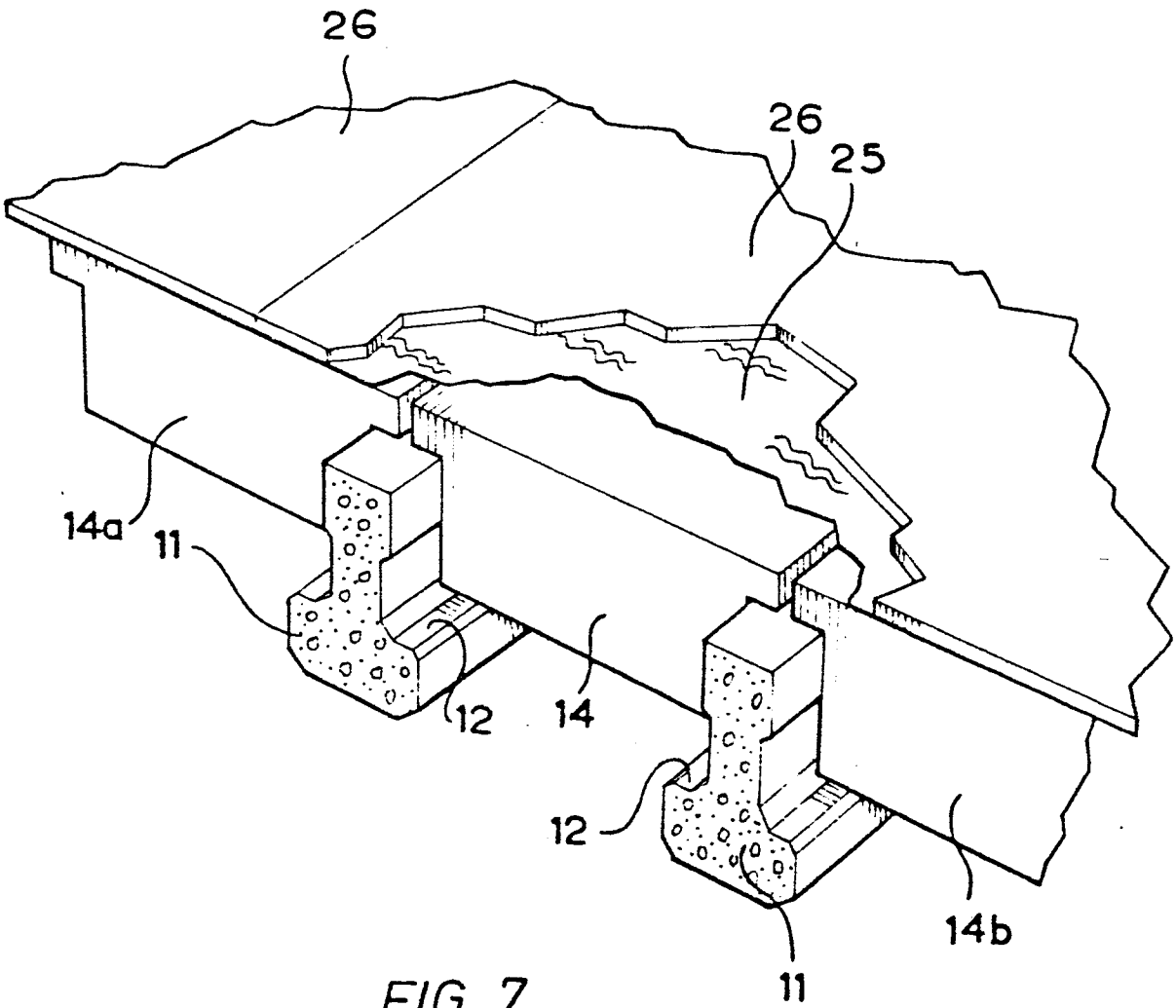

FIG. 7

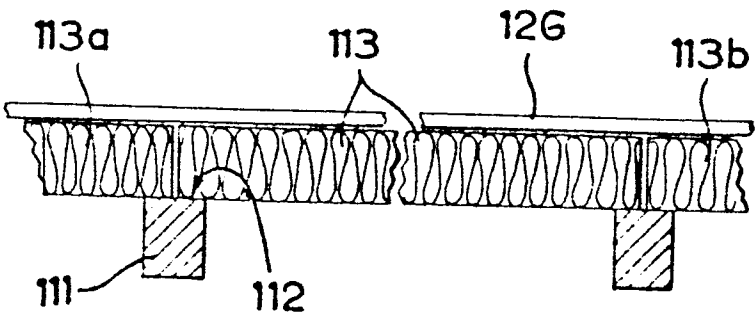

FIG. 8



DOCUMENTS CONSIDERED TO BE RELEVANT			
Category	Citation of document with indication, where appropriate, of relevant passages	Relevant to claim	CLASSIFICATION OF THE APPLICATION (Int. Cl. ³)
A	FR-A-2 202 211 (S.A. ISOBOX) * Whole document *	1, 2, 4, 10	E 04 B 5/04 E 04 B 5/26 E 04 C 1/36
A	FR-A-2 160 729 (A. BECHADE) * Figures 1-3; page 1, lines 13-18 *	1, 2, 4	
A	FR-A-2 173 485 (Y. BOYET) * Figures 1, 2; page 2, lines 11-13 *	1, 2	
A	FR-A-1 532 424 (SURGELATION INDUSTRIELLE ET ENTREPOTS FRIGORIFIQUES SA) * Figure; page 1, column 1 *	1, 2, 4	
A	FR-A-1 057 651 (E. EBERLE) * Figures 1, 2 *	3	TECHNICAL FIELDS SEARCHED (Int. Cl. ³) E 04 B 5/00 E 04 C 1/00
The present search report has been drawn up for all claims			
Place of search BERLIN		Date of completion of the search 09-07-1984	Examiner VON WITTKEN-JUNGNIK
CATEGORY OF CITED DOCUMENTS X : particularly relevant if taken alone Y : particularly relevant if combined with another document of the same category A : technological background O : non-written disclosure P : intermediate document T : theory or principle underlying the invention E : earlier patent document, but published on, or after the filing date D : document cited in the application L : document cited for other reasons & : member of the same patent family, corresponding document			