

N. HAYDEN.

Improvement in Coffin Handles.

No. 132,399.

Patented Oct. 22, 1872.

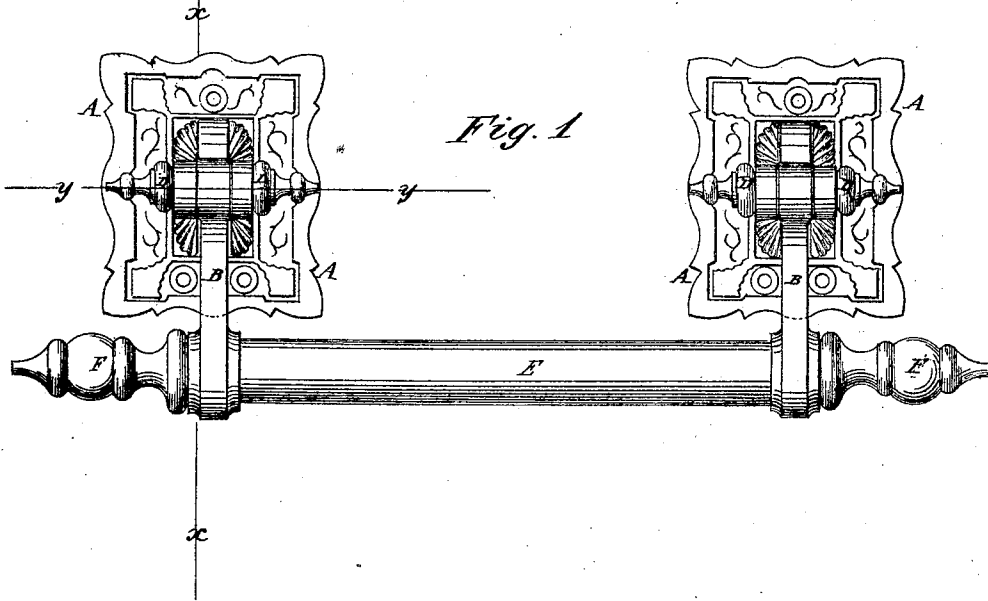

Fig. 1

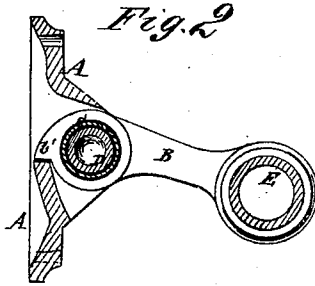

Fig. 2

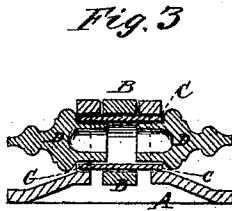

Fig. 3

Witnesses:

A. W. Almqvist
C. S. Quist.

Inventor:

N. Hayden.
PER
Wm. H. [Signature]
Attorneys.

UNITED STATES PATENT OFFICE.

NEHEMIAH HAYDEN, OF ESSEX, CONNECTICUT.

IMPROVEMENT IN COFFIN-HANDLES.

Specification forming part of Letters Patent No. **132,399**, dated October 22, 1872.

To all whom it may concern:

Be it known that I, NEHEMIAH HAYDEN, of Essex, in the county of Middlesex and State of Connecticut, have invented a new and useful Improvement in Coffin-Handles, of which the following is a specification:

Figure 1 is a front view of my improved coffin-handle. Fig. 2 is a detail section of the same taken through the line *x x*, Fig. 1. Fig. 3 is a detail section of the same taken through the line *y y*, Fig. 1.

Similar letters of reference indicate corresponding parts.

My invention has for its object to furnish an improved coffin-handle, neat, tasteful, and beautiful in appearance, and at the same time simple in construction, so that it can be manufactured at small expense; and it consists in the joint formed by the combination of the tube and tips with the ear and end of the arm that supports the hand-piece, as hereinafter more fully described.

A are the ears, which are secured to the coffin by screws. In the centers of the ears A are formed short slots to receive the ends of the arms B. Upon the middle parts of the ears A, upon the opposite sides of the slots through said ears, are formed projections, through which are formed holes to receive the tube C, which is passed through them and through a hole in the end of the arms B to serve as supports and pivots to said arms. The short tubes C may be made of light tin or other suitable

and inexpensive sheet metal, or of wood, and in their ends are inserted the tips D, which may be ornamental or plain. The ears A and their projections may be made of any desired form, size, and style, and may be plain or ornamental to any desired extent. The end of the arms B has a shoulder, *b'*, formed upon it, to rest against the ear A at the lower end of the slot in said ear, to receive the strain when the handle is in use. The end of the arm B may also have another shoulder formed upon it to rest against the ear A at the upper end of its slot, so that the tube C may be almost entirely relieved from the strain. The second shoulder is not essential, as the tube C is abundantly able to sustain any strain that may be put upon it. In the outer end of the arms B is formed a hole to receive the end of the tube E, that serves as a hand-piece, and in the ends of which are inserted tips or caps F, as shown in Fig. 1.

Having thus described my invention, I claim as new and desire to secure by Letters Patent—

In a coffin-handle the joint formed by the combination of the tube C and tips D with the ear A and end of the arm B having one or more shoulders, *b'*, formed upon it, substantially as herein shown and described.

NEHEMIAH HAYDEN.

Witnesses:

JAMES T. GRAHAM,
TOMPSON B. MOSHER.