

(19) World Intellectual Property Organization
International Bureau



(43) International Publication Date
17 July 2003 (17.07.2003)

PCT

(10) International Publication Number
WO 03/058188 A2

- (51) International Patent Classification⁷: G01M
- (21) International Application Number: PCT/US02/41838
- (22) International Filing Date: 31 December 2002 (31.12.2002)
- (25) Filing Language: English
- (26) Publication Language: English
- (30) Priority Data: 60/345,524 3 January 2002 (03.01.2002) US
- (71) Applicant: SYSTECH INTERNATIONAL, L.L.C. [US/US]; Pradeep R. Tripathi, Member, 6075 Jackson Rd., Ann Arbor, MI 48103 (US).
- (72) Inventors: TRIPATHI, Pradeep R.; 5500 Lohr Lake Rd., Ann Arbor, MI 48108 (US). GEILEN, Lothar; 2752 Aspen Ridge, Ann Arbor, MI 48103 (US).
- (74) Agents: VAN DYKE, Daniel et al.; Van Dyke, Gardner, Linn and Burkhart, L.L.P., 2851 Charlevoix Dr., S.E., Ste. 207, P.O. Box 888695, Grand Rapids, MI 49588-8695 (US).
- (81) Designated States (national): AE, AG, AL, AM, AT, AU, AZ, BA, BB, BG, BR, BY, BZ, CA, CH, CN, CO, CR, CU, CZ, DE, DK, DM, DZ, EC, EE, ES, FI, GB, GD, GE, GH, GM, HR, HU, ID, IL, IN, IS, JP, KE, KG, KP, KR, KZ, LC, LK, LR, LS, LT, LU, LV, MA, MD, MG, MK, MN, MW, MX, MZ, NO, NZ, OM, PH, PL, PT, RO, RU, SC, SD, SE, SG, SK, SL, TJ, TM, TN, TR, TT, TZ, UA, UG, UZ, VC, VN, YU, ZA, ZM, ZW.
- (84) Designated States (regional): ARIPO patent (GH, GM, KE, LS, MW, MZ, SD, SL, SZ, TZ, UG, ZM, ZW), Eurasian patent (AM, AZ, BY, KG, KZ, MD, RU, TJ, TM), European patent (AT, BE, BG, CH, CY, CZ, DE, DK, EE, ES, FI, FR, GB, GR, IE, IT, LU, MC, NL, PT, SE, SI, SK, TR), OAPI patent (BF, BJ, CF, CG, CI, CM, GA, GN, GQ, GW, ML, MR, NE, SN, TD, TG).

[Continued on next page]

(54) Title: VEHICLE INSPECTION ENFORCEMENT SYSTEM AND METHOD OFFERING MULTIPLE DATA TRANSMISSIONS ON THE ROAD

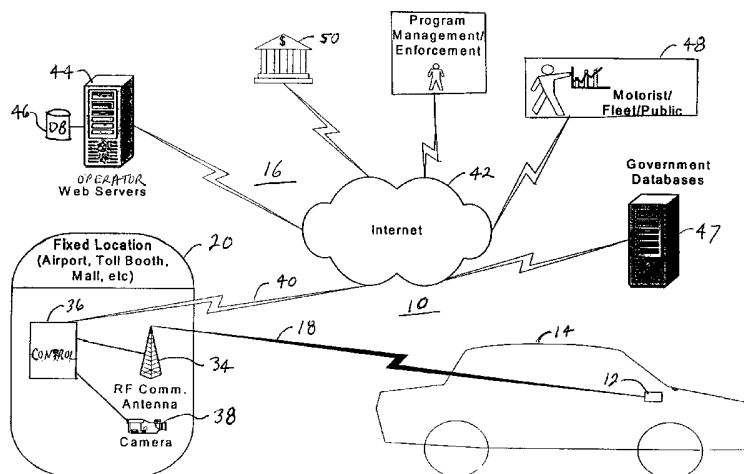

(57) Abstract: A vehicle inspection, diagnosing and maintenance system and method of inspecting, diagnosing and maintaining a vehicle includes providing a vehicle unit and a communications network. The vehicle unit receives vehicle data, such as exhaust emission data, and includes a wireless communication transceiver and a control for controlling the wireless communication transceiver. The control includes memory for storing vehicle data from the vehicle diagnostic system. A communication network provides wireless communication with the vehicle unit. The communication network is made up of a plurality of geographically dispersed generally stationary wireless communication transceivers. The vehicle unit communicates the exhaust emission data in its memory to a stationary transceiver in the vicinity of the vehicle.



WO 03/058188 A2



Published:

— *without international search report and to be republished upon receipt of that report*

For two-letter codes and other abbreviations, refer to the "Guidance Notes on Codes and Abbreviations" appearing at the beginning of each regular issue of the PCT Gazette.

VEHICLE INSPECTION ENFORCEMENT SYSTEM AND METHOD
OFFERING MULTIPLE DATA TRANSMISSIONS ON THE ROAD

CROSS REFERENCE TO RELATED APPLICATION

This application claims priority from United States provisional patent
5 application Serial No. 60/345,524, filed on January 3, 2002, the disclosure of which is
hereby incorporated herein by reference in its entirety.

BACKGROUND OF THE INVENTION

Mandated by USEPA and other government agencies throughout the world,
OBD II (EOBD in Europe) was primarily developed for monitoring the vehicle's
10 emission control systems by the Engine Control Module (ECM), which will typically
display a general warning to the operator (the check engine light, or Malfunction
Indicator Light-MIL) when a fault is detected. It also provides a means by which a
mechanic or vehicle inspector can access engine parameters, readiness status and
specific fault codes related to engine hardware that can affect emissions and engine
15 performance. The OBD II system is accessible via a standardized communications link
and cable, and a microprocessor device that implements various standardized
communications protocol. Such device is known as a scan tool. Data from on-board
sensors can be accessed by the scan tool at a rate of up to 50 Hz.

The United States Environmental Protection Agency (EPA) is currently taking a
20 very clear stand in favor of OBD II (On-board Diagnostic) testing for vehicle emissions
inspections, requiring all non-attainment areas to introduce OBD II testing for all
vehicles (gasoline and diesel powered), model year 1996 and newer in lieu of tailpipe
testing. OBD II interfaces for all vehicles model year 1996 and newer are standardized
to allow for communication with an external microprocessor-based system. Canada has
25 adopted OBD II standardization for all vehicles 1998 and newer. A very similar
international system, called EOBD, is required for model year 1998 and newer vehicles
in Europe. Similar systems are currently being placed in vehicles in Asian markets as
well.

Current new and existing vehicle emission inspection programs typically all
30 follow the following procedure:

1. The motorist drives to an inspection station when the vehicle's emission inspection is due.
2. The vehicle enters a dedicated inspection station.
3. The inspection station may charge a per test fee to the motorist.
- 5 4. The inspector identifies the vehicle (bar code, manually, etc.).
5. The inspector connects the OBD II scan tool to the vehicle's Data Link Connector (DLC) and performs the OBD download according to EPA and program regulations.
6. The inspector disconnects the scan tool from the vehicle.
- 10 7. The inspection results are logged, a VIR may be issued and the data may automatically be transmitted to a centralized database typically through a modem.

Current vehicle emission inspections are time consuming for the motorist, and expensive (rates vary between \$15.00 to \$25.00 and more per test). Therefore, 15 inspections are only performed annually or biennially in order to reduce the burden for the motorist to a minimum. Vehicle performance and compliance between two inspections is not known and cannot be tracked.

SUMMARY OF INVENTION

The present invention addresses the disadvantages resulting from current 20 inspection programs. The invention has the capability of providing much more data than is presently available to enforcing authority, such as authority charged with enforcing vehicle pollution compliance, as well as reducing cost and increasing convenience to the consumer. While the present invention is useful in enforcing compliance with vehicle emission regulations, it may be useful in processing vehicle 25 data other than vehicle exhaust emission parameters in areas without emission testing requirements.

A vehicle inspection system and method of inspecting a vehicle, according to an aspect of the invention, includes providing a vehicle unit and a communications network. The vehicle unit receives vehicle data and has a wireless communication 30 transceiver and a control for controlling the wireless communication transceiver. The control includes memory for storing vehicle data from the vehicle diagnostic system. A communication network provides wireless communication with the vehicle unit. The communication network is made up of a plurality of geographically dispersed generally

stationary wireless communication transceivers. The vehicle unit communicates the vehicle data in its memory to a stationary transceiver in the vicinity of the vehicle.

The vehicle data may include exhaust emission parameters. The vehicle unit may be an adapter that is configured to connect with a diagnostic port of the vehicle diagnostic system for receiving the vehicle data. The communication network may provide two-way wireless communication with the vehicle unit. In this manner, one of the stationary transceivers may activate the vehicle wireless communication transceiver when the vehicle is in the vicinity of that stationary transceiver to communicate the vehicle data to that stationary transceiver. The communication network may include a network connection at the stationary wireless communication transceivers with a wide area network, such as a global network, or the like. This provides for retrieving data from the stationary wireless communication transceiver. The wide area network provides access to the retrieved data at locations remote from the stationary transceivers.

The communication network may further include cameras with the stationary transceivers. The cameras are operable to capture images of vehicles communicating the exhaust emission data. The communication network may include a host computer system on the wide area network that is operative to receive data from the stationary transceivers. The communication network may further include a database on the wide area network for storing historical vehicle data from the vehicle unit. Current vehicle data may be compared with historical exhaust emission data to determine if the vehicle is operating outside of normal operation. Environmental authority may be provided access to the database for compliance verification. Additionally, a vehicle owner, such as an individual owner or a vehicle fleet operator, may be provided access to the database for vehicle performance monitoring.

A unique vehicle identification code may be provided wherein the vehicle code is transmitted with the vehicle data. The vehicle wireless communication transceiver may communicate auxiliary data, in addition to the other vehicle data in the memory, to the stationary transceiver. The network connection may include at least one chosen from a high-speed installed connection, a wireless connection, such as a cellular connection, or a satellite connection. The control in the vehicle unit may be programmed through the vehicle transceiver with code received from the stationary transceivers. The communication network may track the geographic location of the vehicle unit.

These and other objects, advantages and features of this invention will become apparent upon review of the following specification in conjunction with the drawings.

BRIEF DESCRIPTION OF THE DRAWINGS

Fig. 1 is a block diagram of a vehicle exhaust emission inspection system and method, according to the invention;

Fig. 2 is a block diagram of a vehicle unit;

Fig. 3 is a diagram illustrating communication between a stationary unit and a vehicle unit;

Figs 4a and 4b are flowcharts of a control program at a vehicle unit; and

Figs 5a and 5b are flowcharts of a control program at a stationary unit.

DESCRIPTION OF THE PREFERRED EMBODIMENTS

Referring now to the drawings and the illustrative embodiments depicted therein, a vehicle exhaust emission inspection system 10 includes a vehicle unit 12 positioned within a vehicle 14 and a communication network 16 for wireless communication, shown at 18, with vehicle unit 12 (Fig. 1). Communication network 16 is made up of a plurality of geographically dispersed generally stationary units 20, each having a wireless communication transceiver, such as a two-way transceiver. Vehicle unit 12 communicates with a stationary unit 20 that is in the vicinity of the vehicle. Generally stationary units 20 may be positioned at various locations including airports, tollbooths, malls and other publicly accessible areas along roadways. Communication between the vehicle unit and the stationary unit may be by one of various wireless techniques, such as radio frequency (RF) techniques, and may utilize particular commercially available protocols such as Bluetooth, or the like. The hardware elements used to implement the stationary units and the vehicle units, such as the controls and the transceivers, are conventional and within information available to those skilled in the art.

Vehicle unit 12 includes a wireless communication transceiver 22, such as a two-way transceiver, and a control, such as a microprocessor-based control 24, for controlling communication transceiver 22. Control 24 includes memory 26, such as a flash memory, for storing vehicle exhaust emission data from a vehicle diagnostic system 28. Such diagnostic systems are conventional with modern vehicles and provide various vehicle operating data including vehicle speed, various engine parameters, and various exhaust emission parameters. In the illustrative embodiment,

vehicle diagnostic system 28 is illustrated as an on-board digital (OBD) II computer system, although other diagnostic systems are available.

Vehicle unit 12 may include an adapter 30 in the form of a reader circuit configured to connect with vehicle diagnostic system 28, such as through a diagnostic port, or vehicle diagnostic link connector (DLC), for receiving at least exhaust emission data from diagnostic system 28. Such reader circuits are well known in the art and are commercially available in various diagnostic scan tools. Microprocessor 24 issues commands to the adapter 30 for it to issue commands to and receive data from the vehicle diagnostic system 28. Memory 26 stores relevant data, which may include vehicle exhaust emission parameters, for subsequent transmission to communication network 26, as will be explained in more detail below. Vehicle unit 12 is powered through a connection with a vehicle power source 32 which may be a separate connection or may be a connection through the vehicle diagnostic link connector (DLC). In this manner, vehicle unit 12 is powered whenever the vehicle is running. When the vehicle is powered up, vehicle data is stored in memory 26. When the vehicle is powered on, control 24 may check to ensure that the adapter is on the same vehicle by comparing current and old data. In the illustrative embodiment, vehicle unit 12 is adapted to be connected with the vehicle diagnostic link connector and, therefore, may be installed in existing vehicles. However, the invention comprehends incorporating vehicle unit 12 in the manufacturing of a vehicle.

Stationary unit 20 includes a wireless transceiver 34 for wireless communication 18 with vehicle unit 12 and a control system 36 for controlling transceiver 34. When a vehicle unit 12 is in the vicinity of stationary unit 20, vehicle unit 12 communicates data, such as vehicle exhaust emission parameters, via wireless communication 18 to that stationary unit 20. To assist this function, stationary unit 20 may serve as a beacon to activate a vehicle unit 12 in its vicinity to transmit its data. This may be accomplished by the two-way wireless communication capability of stationary unit 20. Therefore, a stationary unit 20 may repetitively send out a wireless beacon signal, which is received by a vehicle unit 12 in the vicinity of that stationary unit. In response to the wireless beacon signal, the vehicle unit 12 transmits vehicle data obtained from the vehicle diagnostic system and stored in memory 26, via wireless communication 18 to that stationary unit 20. The use of transceiver 34 to emit a beacon signal may minimize the requirement for communication regulatory controls and

facilitates wireless communication 18 with vehicle unit 12 without recurring communication charges as may occur with a cellular system, or the like.

Stationary unit 20 may include an image capture device 38, such as a camera, in order to capture images of the vehicle 14 whose vehicle unit 12 is communicating exhaust emission data via wireless communication 18. The images may be still or may be video images of the vehicle and may serve the purpose of providing additional vehicle authentication, if required. Vehicle identification may include vehicle outline, vehicle color, structural details, and the like. License plate information could also be captured. Communication network 16 may include a network connection 40 with a wide area network, 42, such as a global network such as the Internet or other such network. Network connection 40 may be via a high-speed installed connection, such as cable, DSL, T1, or the like, or may be a wireless connection, such as a cellular connection, or may be a satellite connection, or the like. This connection with wide area network 42 allows data from each stationary unit 20 to be retrieved remotely at locations remote from the stationary units 20. Retrieving data from stationary units 20 may be done in real time or through batch processing.

Such remote retrieving may be in the form of a host computer system (HCS) 44 consisting of an enterprise network environment made up of one or more servers. Such HCS may provide a computing environment that is scalable to be used for vehicle fleets or geographical regions, such as city, states, or nations, or the like. Host computer system 44 may support a database 46 of historical vehicle data of vehicle 14, as well as other vehicles utilizing a vehicle unit 12. In this manner, when current vehicle data is retrieved from vehicle unit 12 via wireless communication 18, HCS 44 may compare the current vehicle data with the historical vehicle data for the vehicle. HCS 44 may utilize this comparison to determine if the vehicle is operating outside of normal operation as disclosed in detail in commonly assigned International Application Publication No. WO 01/86576, published on November 15, 2001, entitled MONITORING OF VEHICLE HEALTH BASED ON HISTORICAL INFORMATION, the disclosure of which is hereby incorporated herein in its entirety by reference.

In addition, a government computer 47, incorporating an environmental protection database, may utilize vehicle exhaust emission data retrieved via wireless communication 18 and stationary unit 20 via global network 42 in order to determine compliance of the vehicle 14 with exhaust emission regulations. In this manner, the

government may receive many data points from a vehicle, rather than once every one or two years as with conventional exhaust emission inspections.

Other users may utilize the data retrieved from the stationary units 20. By way of example, a vehicle owner, such as an individual owner or a fleet operator 48, may
5 monitor vehicle data retrieved from unit 12 in order to monitor vehicle performance and identify vehicles that require maintenance. Additionally, communication network 16 may provide the ability to track the geographic location of unit 14 which may also be of interest to fleet operator 48.

Rather than utilizing separate access points 47 and 48, various users including
10 the government, vehicle fleet operators and individual vehicle owners may be provided selective access to database 46 at HCS 44. Access to these various parties may be via a personal web page for each user that allows restricted access to that user as well as requires proper verification of the identification of that user. In this manner, by way of example, an individual vehicle owner may have access to vehicle data for that owner's
15 vehicle and a fleet operator can have access to the data pertaining to the vehicles in that fleet. Governmental authorities may have a more global access to all records for the appropriate jurisdiction. However, such authority may be restricted from various information, such as account information, which will be discussed below, and the like.

Vehicle unit 12 may additionally be assigned a unique vehicle identification
20 code. This unique vehicle identification code may be transmitted along with the vehicle data to the stationary unit. With the ability to uniquely identify the vehicle unit making the transmission, auxiliary data may also be transmitted along with the vehicle exhaust emission data for other purposes. By way of example, the auxiliary data may be utilized to perform automatic banking transactions pertaining to user operation of
25 system 10, such as with an institution, illustrated as a bank 50. Such access may be for the purpose of charging the user for use of the system, such as on a transactional basis, including test fees, subscription fees, and the like. Other auxiliary data may be utilized for commercial applications, such as EZ-pass and other tollbooth-type applications, paying for food at take-out windows of fast-food restaurants, and the like. The ability
30 to carry out such transaction is made possible by the use of a unique identification code that is matched to a particular vehicle. The personal web page set up with HCS for each user may also provide tools for managing the account set up for that user.

Inspection system 10 may incorporate other useful features. By way of example, communication network 16 may download, through wireless communication

18 to vehicle unit 12, code that may be used to program the vehicle unit 12.

Additionally, self-testing may be incorporated into the inspection system in order to provide diagnostics for determining that the vehicle unit is properly operating.

However, system 10 is not limited to exhaust emission inspections. It may be useful
5 for general diagnostics and maintenance of vehicles. By way of example, the vehicle owner may be notified automatically, such as by E-mail if the owner's vehicle data is out of specification. All of this can be accomplished in a fully automated manner without any effort on behalf of the owner. Thus, the present invention provides a full, self-service paperless-based system.

10 Advantageously, inspection system 10 may perform vehicle exhaust emission inspections without manual intervention. Not only does this minimize the cost of determining compliance, but reduces inconvenience to the driver. Advantageously, inspection system 10 may be field retrofitted into existing vehicles thereby extending the advantage of a data collection system to older vehicles. Such a retrofit solution may
15 be financed, for example, by incentives provided by the Government Compliance Agency.

An example of communication between stationary unit 20 and a vehicle unit 12 is illustrated in Fig 3. Stationary unit 20 sends out, repetitively, a beacon 56 during a Beacon Slot. When the vehicle is within range of the beacon, the vehicle unit responds
20 during a Session Slot with a BACK signal 58. The stationary unit then responds by sending a RBACK signal 60, which identifies which vehicle data the stationary unit wishes to receive. The vehicle unit responds by sending various data packets 62a, 62b of vehicle data. If the data is successfully received by the stationary unit, using conventional error checking techniques, an acknowledge signal 64 is sent. In the
25 illustrative embodiment, the range of transmission of the stationary unit is 250 meters, but a greater or lesser range may be used.

Operation of the vehicle unit is set forth in more detail in Figs 4a and 4b. Upon power-up at 68, the unit is initialized at 70 and attempts are made to receive a beacon at
72. Once a beacon is received, the vehicle unit synchronizes with the beacon at 74 and
30 76. The vehicle unit then sends a BACK signal at 78, switches to a receive mode at 80 and looks for the RBACK signal at 82. After a number of attempts (84, 86) communication is ended at 88. Once the RBACK signal is received, the unit is switched to transmitting at 90, packets 62a, 62b are sent at 92 and the unit is switched to receiving at 94 to look for the acknowledge signal at 96 and 98. After a number of

attempts at 102, communication is terminated at 104. If acknowledge is received at 98, communication is terminated at 100.

Operation of the stationary unit is set forth in more detail in Figs 5a and 5b. After power-up at 112 and initialization at 114, the beacon 56 is repetitively transmitted at 116. The unit then switches to a receive mode at 118 and waits at 120 for a BACK
5 signal (122, 124, 126). Once received, the unit switches to a transmit mode at 128 and sends an RBACK signal at 130. The unit then switches to a receive mode at 132 and receives, at 134, data packets sent by the vehicle unit. They are checked for validity at
10 140 and either an acknowledge signal is sent (142, 144, 150) or a non-acknowledge signal is sent (146, 148, 150).

Changes and modifications in the specifically described embodiments can be carried out without departing from the principles of the invention which is intended to be limited only by the scope of the appended claims, as interpreted according to the principles of patent law including the Doctrine of Equivalents.

The embodiments of the invention in which an exclusive property or privilege is claimed are defined as follows:

1. A vehicle inspection system, comprising:
 - a vehicle unit comprising a vehicle wireless communication transceiver and a control for controlling said wireless communication transceiver, said control including memory for storing vehicle data including exhaust emission parameters from a vehicle diagnostic system; and
 - a communication network for two-way wireless communication with said vehicle unit, said communication network made up of a plurality of geographically dispersed generally stationary wireless communication transceivers, wherein one of said stationary transceivers activates said vehicle wireless communication transceiver when in a vicinity of that stationary transceiver to communicate vehicle data in said memory to that stationary transceiver.
2. The system of claim 1 wherein said communication network including network connection at said stationary wireless communication transceivers with a wide area network, said wide area network retrieving vehicle data from said stationary wireless communication transceivers and providing access to the retrieved vehicle data at locations remote from said stationary transceivers.
3. The system of claim 2 wherein said communication network includes a host computer system on said wide area network operative to receive data from said stationary transceivers and a database for storing historical vehicle data from said vehicle unit.
4. The system of claim 3 wherein current vehicle data is compared with historical vehicle data to determine if the vehicle is operating outside of normal operation.
5. The system of claim 1 wherein environmental authority is provided access to said communication network for compliance verification.
6. The system of claim 1 wherein a vehicle owner is provided access to said communication network for vehicle performance monitoring.

7. The system of claim 1 including a unique vehicle identification code, wherein said identification code is transmitted with the vehicle data to that stationary transceiver.
8. The system of claim 6 wherein said vehicle data includes auxiliary data in addition to the exhaust emission parameters.
9. The system of claim 2 wherein said network connection comprises at least one chosen from a high speed installed connection, a wireless connection and a satellite connection.
10. The system of claim 1 wherein said control is programmable through said vehicle transceiver with code received from said stationary transceivers.
11. The system of claim 1 wherein said communication network tracks the geographic location of said vehicle unit.
12. The system of claim 1 wherein said communication network includes cameras with said stationary transceivers operable to capture images of vehicles communicating exhaust emission data.
13. A vehicle inspection system, comprising:
 - a vehicle unit comprising an adapter configured to connect with a vehicle diagnostic port of a vehicle diagnostic system for receiving vehicle data including exhaust emission parameters, a vehicle wireless communication transceiver and a control for controlling said adapter and said wireless communication transceiver, said control including memory for storing vehicle data from the vehicle diagnostic system; and
 - a communication network for two-way wireless communication with said vehicle unit, said communication network made up of a plurality of geographically dispersed generally stationary wireless communication transceivers, wherein said vehicle wireless communication transceiver communicates vehicle data in said memory to a stationary transceiver in a vicinity of that said vehicle unit.

14. The system of claim 13 wherein said communication network including network connection at said stationary wireless communication transceivers with a wide area network, said wide area network retrieving vehicle data from said stationary wireless communication transceivers and providing access to the retrieved vehicle data at locations remote from said stationary transceivers.
15. The system of claim 14 wherein said communication network includes a host computer system on said wide area network operative to receive data from said stationary transceivers and a database for storing historical vehicle data from said vehicle unit.
16. The system of claim 15 wherein current vehicle data is compared with historical vehicle data to determine if the vehicle is operating outside of normal operation.
17. The system of claim 13 wherein environmental authority is provided access to said communication network for compliance verification.
18. The system of claim 13 wherein a vehicle owner is provided access to said communication network for vehicle performance monitoring.
19. The system of claim 13 including a unique vehicle identification code, wherein said identification code is transmitted with the vehicle data to that stationary transceiver.
20. The system of claim 19 wherein said vehicle data includes auxiliary data in addition to the exhaust emission parameters.
21. The system of claim 14 wherein said network connection comprises at least one chosen from a high speed installed connection, a wireless connection and a satellite connection.
22. The system of claim 13 wherein said control is programmable through said vehicle transceiver with code received from said stationary transceivers.

23. The system of claim 13 wherein said communication network tracks the geographic location of said vehicle unit.
24. The system of claim 13 wherein said communication network includes cameras with said stationary transceivers operable to capture images of vehicles communicating exhaust emission data.
25. A method of inspecting a vehicle, comprising:
providing a vehicle unit comprising a vehicle wireless transceiver and a memory;
storing in said memory vehicle data including exhaust emission parameters from a vehicle diagnostic system;
providing a communication network for two-way wireless communication with said vehicle unit, said communication network made up of a plurality of geographically dispersed generally stationary wireless communication transceivers;
activating said vehicle wireless communication transceiver with one of said stationary transceivers when said vehicle wireless communication transceiver is in a vicinity of that stationary transceiver to communicate the stored vehicle data to that stationary transceiver.
26. The method of claim 25 including providing a network connection at said stationary wireless communication transceivers with a wide area network; and
retrieving vehicle data from said stationary wireless communication transceivers with said wide area network and providing access to the retrieved vehicle data at locations remote from said stationary transceivers.
27. The method of claim 26 including providing a host computer system on said wide area network for receiving data from said stationary transceivers and a database for storing historical vehicle data from said vehicle unit with said database.
28. The method of claim 27 including comparing current vehicle data with historical vehicle data to determine if the vehicle is operating outside of normal operation.

29. The method of claim 27 including providing access by environmental authority to said database for compliance verification.
30. The method of claim 27 including providing access by a vehicle owner to said database for vehicle performance monitoring.
31. The method of claim 25 including providing a unique vehicle identification code and transmitting said identification code with the vehicle data.
32. The method of claim 31 wherein said vehicle data includes auxiliary data in addition to the exhaust emission.
33. The method of claim 26 wherein said network connection comprises at least one chosen from a high speed installed connection, a wireless connection and a satellite connection.
34. The method of claim 25 including programming said vehicle unit through said vehicle transceiver with code received from said stationary transceivers.
35. The method of claim 25 including tracking the geographic location of said vehicle unit with said communication network.
36. The method of claim 25 including providing cameras with said stationary transceivers and capturing images with said cameras of vehicles communicating exhaust emission data.
37. A method of inspecting a vehicle, comprising:
providing a vehicle unit comprising an adapter and a vehicle wireless transceiver;
connecting said vehicle unit with a diagnostic port of a vehicle diagnostic system and receiving vehicle data including exhaust emission parameters with said vehicle unit;
storing vehicle data from the vehicle diagnostic port;

providing a communication network for two-way wireless communication with said vehicle unit, said communication network made up of a plurality of geographically dispersed generally stationary wireless communication transceivers; and

communicating the stored exhaust emission data to that stationary transceiver in a vicinity of that vehicle unit.

38. The method of claim 37 including providing a network connection at said stationary wireless communication transceivers with a wide area network; and

retrieving vehicle data from said stationary wireless communication transceivers and with said wide area network and providing access to the retrieved vehicle data at locations remote from said stationary transceivers.

39. The method of claim 38 including providing a host computer system on said wide area network for receiving data from said stationary transceivers and a database for storing historical vehicle data from said vehicle unit with said database.

40. The method of claim 39 including comparing current vehicle data with historical vehicle data to determine if the vehicle is operating outside of normal operation.

41. The method of claim 39 including providing access by environmental authority to said database for compliance verification.

42. The method of claim 39 including providing access by a vehicle owner to said database for vehicle performance monitoring.

43. The method of claim 37 including providing a unique vehicle identification code and transmitting said identification code with the vehicle data.

44. The method of claim 43 wherein said vehicle data includes auxiliary data in addition to the exhaust emission.

45. The method of claim 38 wherein said network connection comprises at least one chosen from a high speed installed connection, a wireless connection and a satellite connection.
46. The method of claim 37 including programming said vehicle unit through said vehicle transceiver with code received from said stationary transceivers.
47. The method of claim 37 including tracking the geographic location of said vehicle unit with said communication network.
48. The method of claim 37 including providing cameras with said stationary transceivers and capturing images with said cameras of vehicles communicating exhaust emission data.
49. A vehicle diagnosing and maintenance system, comprising:
a vehicle unit comprising a vehicle wireless communication transceiver and a control for controlling said wireless communication transceiver, said control including memory for storing vehicle data including exhaust emission parameters from a vehicle diagnostic system; and
a communication network for two-way wireless communication with said vehicle unit, said communication network made up of a plurality of geographically dispersed generally stationary wireless communication transceivers, wherein said vehicle wireless communication transceiver communicates vehicle data in said memory to a stationary transceiver in a vicinity of that said vehicle unit;
said communication network automatically determining if the vehicle data is out of specification and automatically notifying a vehicle owner thereof.
50. A method of inspecting a vehicle, comprising:
providing a vehicle unit comprising a vehicle wireless transceiver and a memory;
storing in said memory vehicle data including exhaust emission parameters from a vehicle diagnostic system;

providing a communication network for two-way wireless communication with said vehicle unit, said communication network made up of a plurality of geographically dispersed generally stationary wireless communication transceivers;

communicating the stored exhaust emission data to that stationary transceiver in a vicinity of that vehicle unit; and

automatically determining with said communication network if the vehicle data is out of specification and automatically notifying with said communication network a vehicle owner thereof.

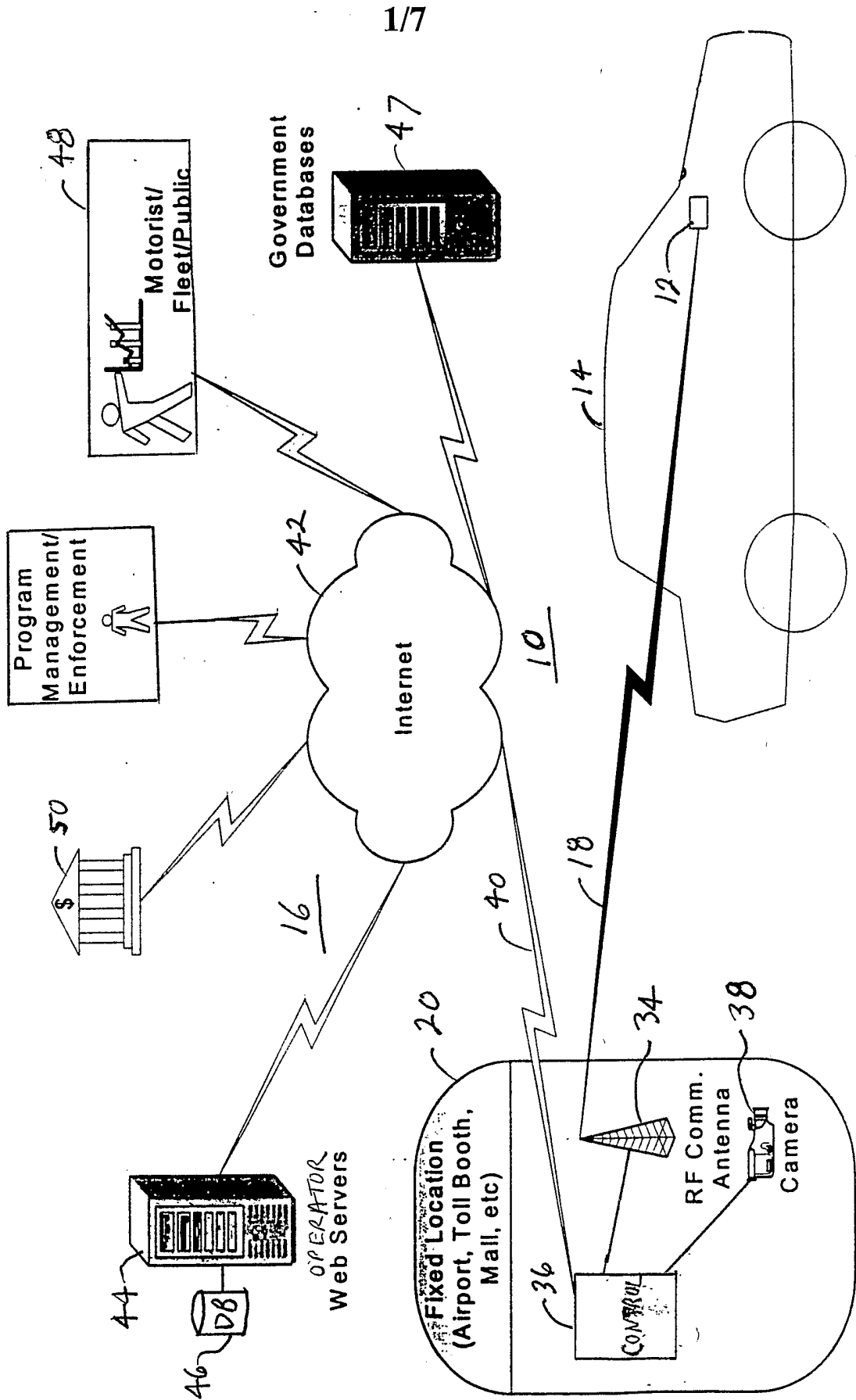

Fig 1

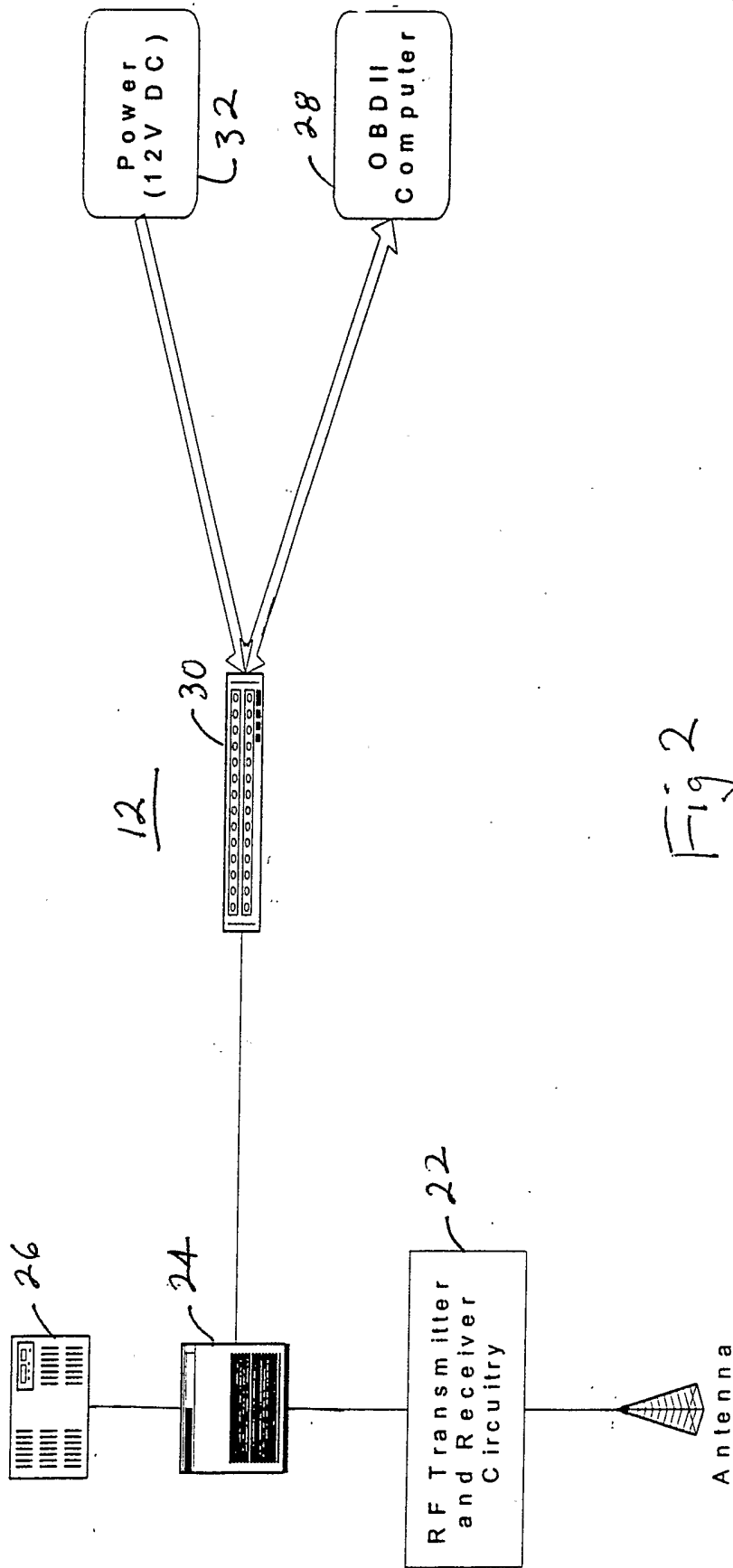

Fig 2

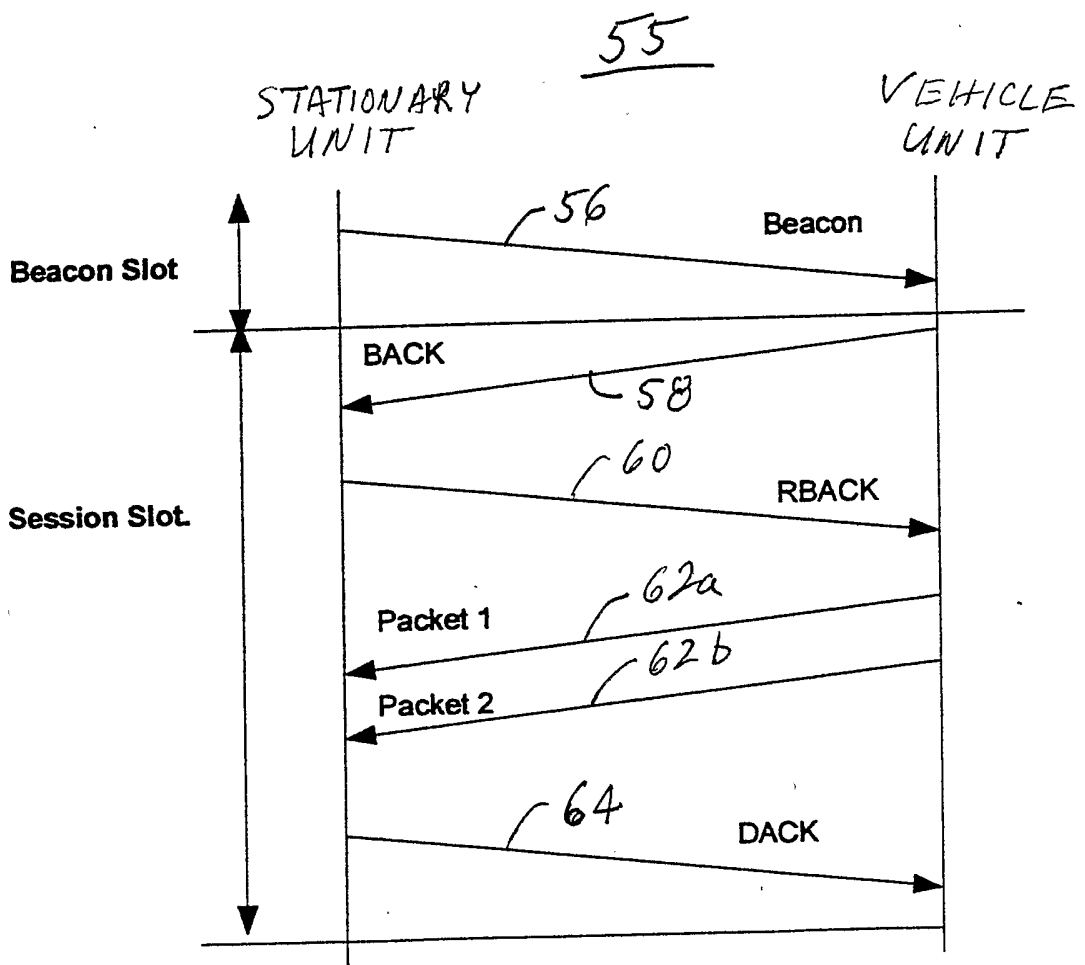

Fig 3

4/7

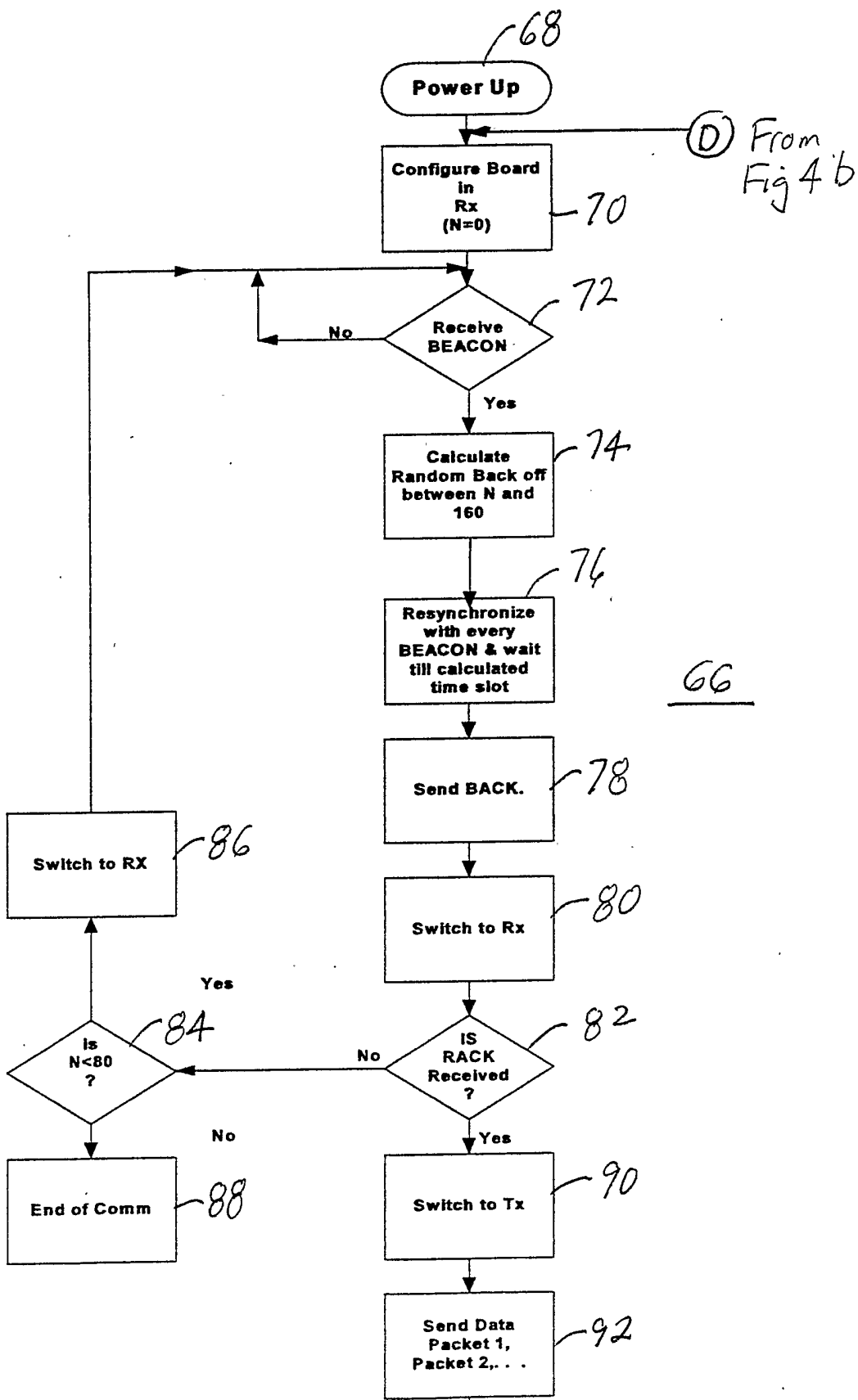

Fig 4a

C To Fig 4b

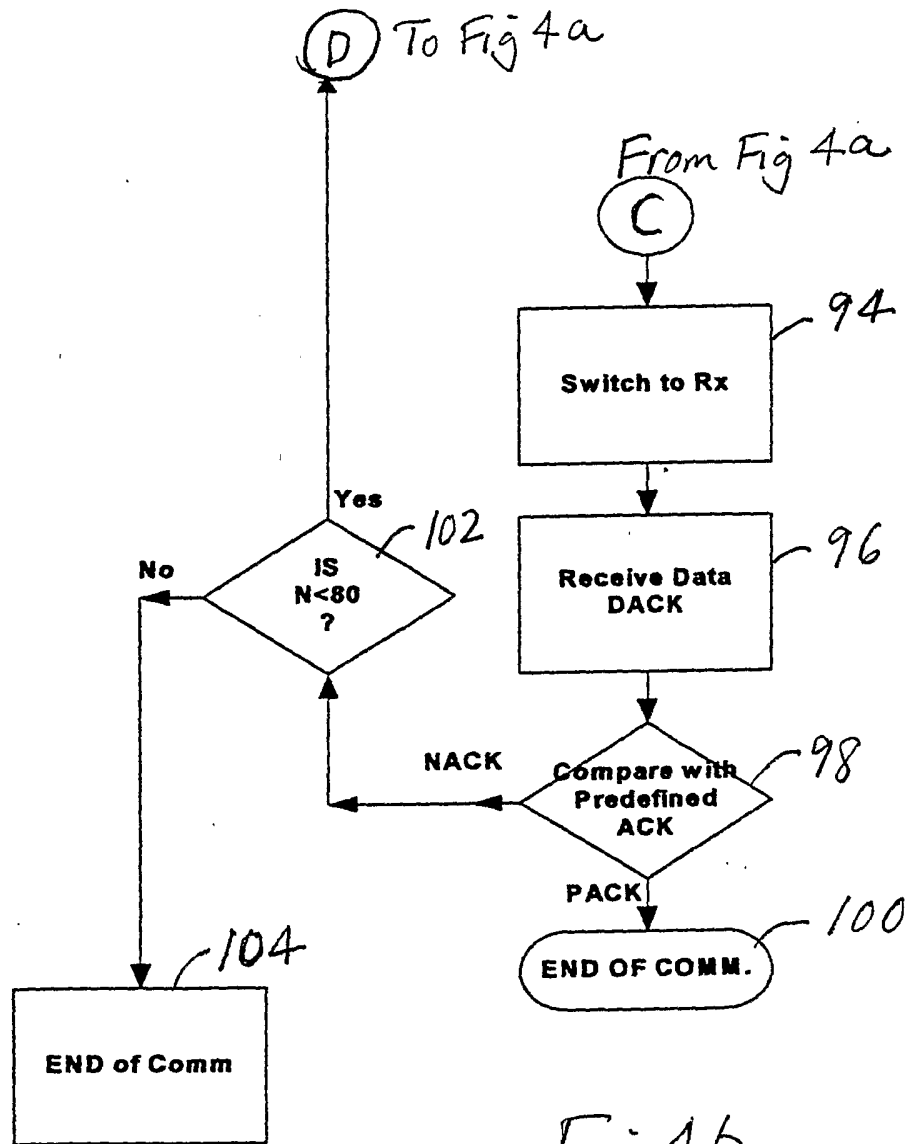

Fig 4b

6/7

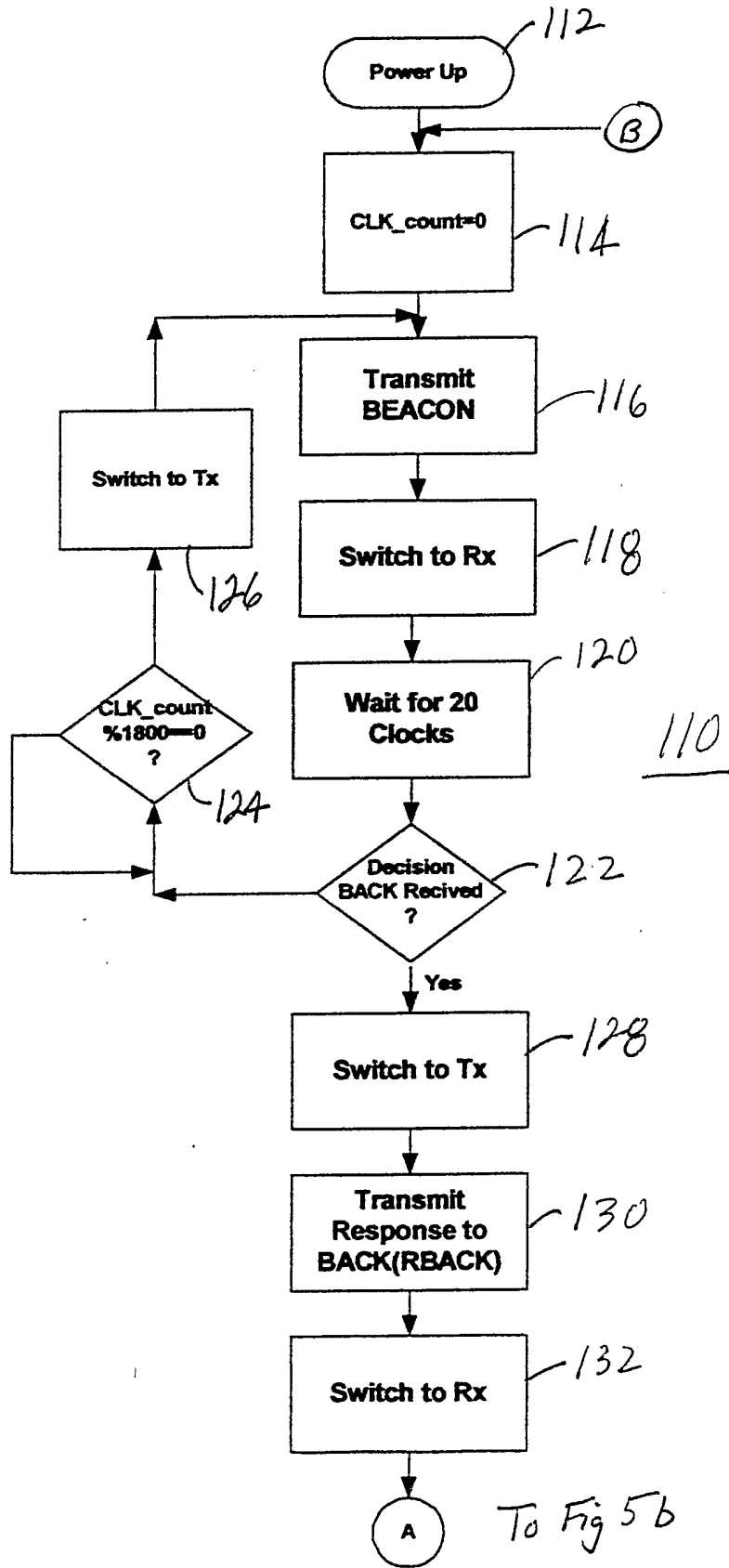

Fig 5a

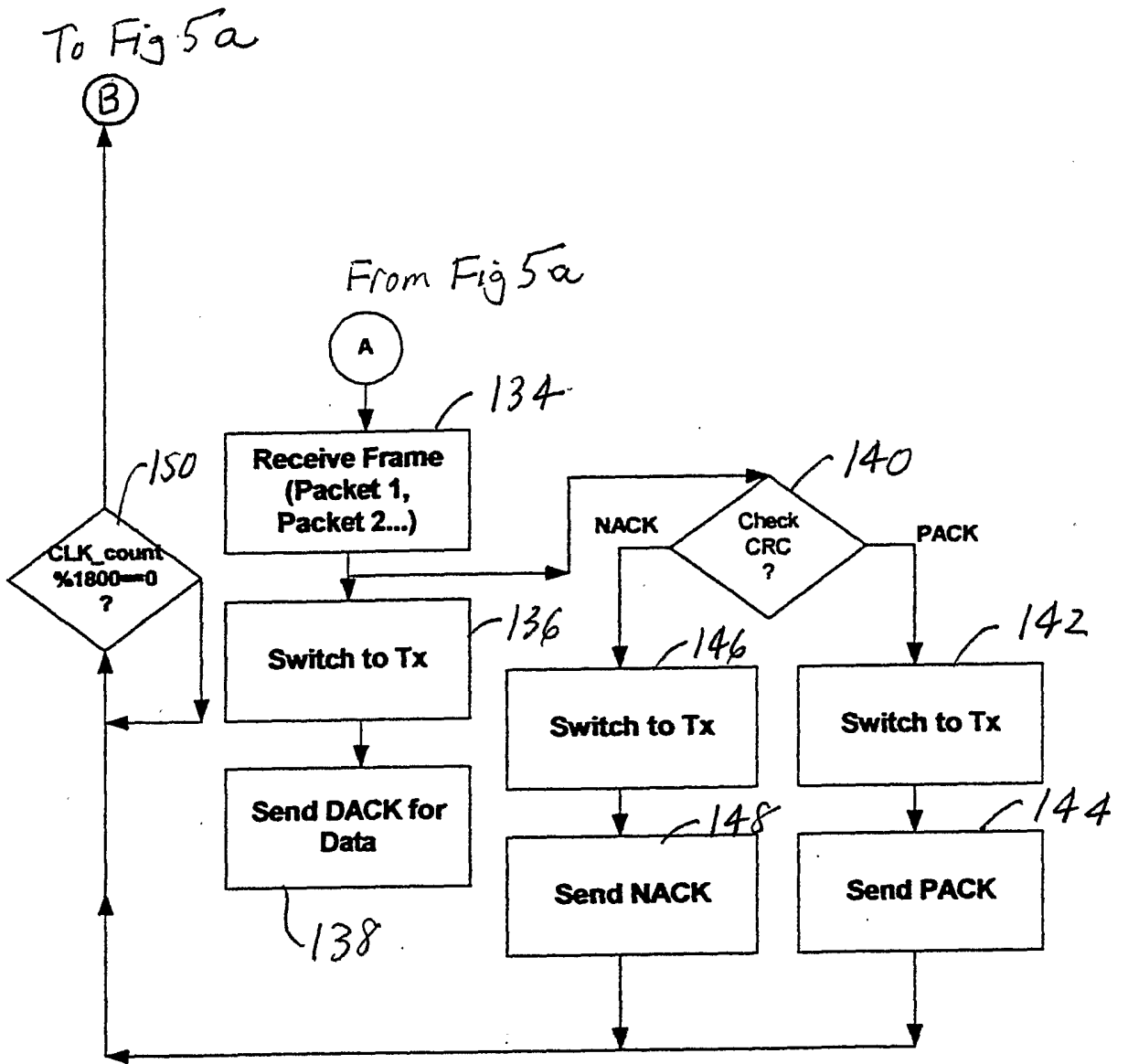

Fig 5b