



INTERNATIONAL APPLICATION PUBLISHED UNDER THE PATENT COOPERATION TREATY (PCT)

(51) International Patent Classification ⁷ : B41M 5/035	A1	(11) International Publication Number: WO 00/61376 (43) International Publication Date: 19 October 2000 (19.10.00)
--	-----------	--

(21) International Application Number: PCT/BE00/00029

(22) International Filing Date: 4 April 2000 (04.04.00)

(30) Priority Data:
9900237 7 April 1999 (07.04.99) BE(71) Applicant (for all designated States except US):
TECHNI-COAT INTERNATIONAL NAAMLOZE
VENNOOTSCHAP [BE/BE]; Missiehuislei 11, B-2920
Kalmthout (BE).

(72) Inventors; and

(75) Inventors/Applicants (for US only): LAFAILLE, Marc, Maria,
Leo, Jan [BE/BE]; Asterlaan 5, B-2950 Kappellen (BE).
THIJS, Frank, François [BE/ES]; Caja Del Romeral No. 22,
E-03580 Alfaz del Pi-Alicante (ES).(74) Agent: DONNE, Eddy; Bureau M.F.J. Bockstael nv, Aren-
bergstraat 13, B-2000 Antwerpen (BE).(81) Designated States: AE, AG, AL, AM, AT, AU, AZ, BA, BB,
BG, BR, BY, CA, CH, CN, CR, CU, CZ, DE, DK, DM,
DZ, EE, ES, FI, GB, GD, GE, GH, GM, HR, HU, ID, IL,
IN, IS, JP, KE, KG, KP, KR, KZ, LC, LK, LR, LS, LT, LU,
LV, MA, MD, MG, MK, MN, MW, MX, NO, NZ, PL, PT,
RO, RU, SD, SE, SG, SI, SK, SL, TJ, TM, TR, TT, TZ,
UA, UG, US, UZ, VN, YU, ZA, ZW, ARIPO patent (GH,
GM, KE, LS, MW, SD, SL, SZ, TZ, UG, ZW), Eurasian
patent (AM, AZ, BY, KG, KZ, MD, RU, TJ, TM), European
patent (AT, BE, CH, CY, DE, DK, ES, FI, FR, GB, GR,
IE, IT, LU, MC, NL, PT, SE), OAPI patent (BF, BJ, CF,
CG, CI, CM, GA, GN, GW, ML, MR, NE, SN, TD, TG).**Published***With international search report.**Before the expiration of the time limit for amending the
claims and to be republished in the event of the receipt of
amendments.*

(54) Title: METHOD AND DEVICE FOR PRINTING OBJECTS

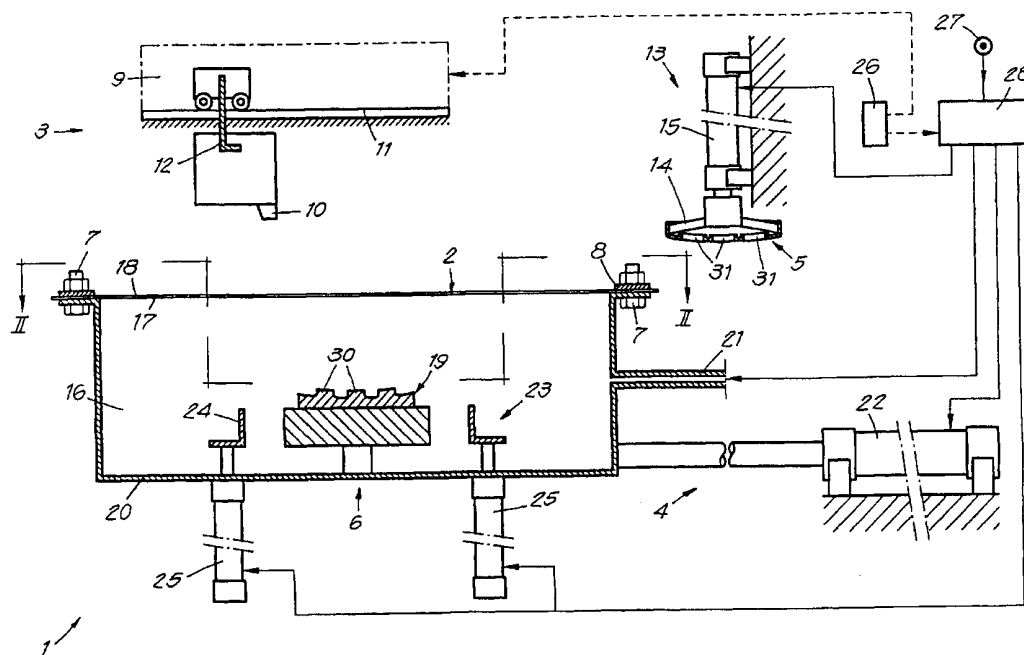

(57) Abstract

Methods for printing objects, characterized in that it at least consists in, on one hand, applying printing ink (29) on a carrier (2) consisting of a flexible layer-shaped material and, on the other hand, transferring the printing ink (29) to the object (5) to be printed, by bringing said carrier (2) and the object (5) in mutual contact and by pressing it on, by means of supplementary pressing means (6), at least partially around the object (5) to be printed.

FOR THE PURPOSES OF INFORMATION ONLY

Codes used to identify States party to the PCT on the front pages of pamphlets publishing international applications under the PCT.

AL	Albania	ES	Spain	LS	Lesotho	SI	Slovenia
AM	Armenia	FI	Finland	LT	Lithuania	SK	Slovakia
AT	Austria	FR	France	LU	Luxembourg	SN	Senegal
AU	Australia	GA	Gabon	LV	Latvia	SZ	Swaziland
AZ	Azerbaijan	GB	United Kingdom	MC	Monaco	TD	Chad
BA	Bosnia and Herzegovina	GE	Georgia	MD	Republic of Moldova	TG	Togo
BB	Barbados	GH	Ghana	MG	Madagascar	TJ	Tajikistan
BE	Belgium	GN	Guinea	MK	The former Yugoslav Republic of Macedonia	TM	Turkmenistan
BF	Burkina Faso	GR	Greece			TR	Turkey
BG	Bulgaria	HU	Hungary	ML	Mali	TT	Trinidad and Tobago
BJ	Benin	IE	Ireland	MN	Mongolia	UA	Ukraine
BR	Brazil	IL	Israel	MR	Mauritania	UG	Uganda
BY	Belarus	IS	Iceland	MW	Malawi	US	United States of America
CA	Canada	IT	Italy	MX	Mexico	UZ	Uzbekistan
CF	Central African Republic	JP	Japan	NE	Niger	VN	Viet Nam
CG	Congo	KE	Kenya	NL	Netherlands	YU	Yugoslavia
CH	Switzerland	KG	Kyrgyzstan	NO	Norway	ZW	Zimbabwe
CI	Côte d'Ivoire	KP	Democratic People's Republic of Korea	NZ	New Zealand		
CM	Cameroon			PL	Poland		
CN	China	KR	Republic of Korea	PT	Portugal		
CU	Cuba	KZ	Kazakstan	RO	Romania		
CZ	Czech Republic	LC	Saint Lucia	RU	Russian Federation		
DE	Germany	LI	Liechtenstein	SD	Sudan		
DK	Denmark	LK	Sri Lanka	SE	Sweden		
EE	Estonia	LR	Liberia	SG	Singapore		

Method and device for printing objects.

5 This invention relates to a method and a device for printing objects, more particularly for printing the surface of three-dimensional objects.

10 A practical application intended by the invention is the application of a decorative coating on the casing of portable telephones, in particular on the front side of GSM devices. It is known that the front side of such devices comprises inwardly-directed parts, such as, for example, the seats of the push-buttons. Generally, these front sides are provided with a colour or ink coating by
15 means of a paint spraying technique. A disadvantage of this technique consists in that it is difficult to provide the inward-bent parts with ink and/or colour. This becomes even more difficult when the coating must not consist of only one and the same colour layer and,
20 for example, it is desired to form images on the front side, as then it is necessary to work with masks. Another disadvantage consists in that this technique is little environment-friendly, as a large part of the colour or ink will get beside the object.

25

The present invention in the first place aims at a method and a device which are particularly suited for printing three-dimensional objects. More particularly, it aims at a technique whereby the aforementioned disadvantages when
30 printing the front side of GSM devices and similar, are excluded.

To this aim, the invention concerns a method for printing objects, with as a characteristic that it at least
35 consists in, on one hand, the application of printing ink on a carrier consisting of a flexible layer-shaped

material and, on the other hand, transferring the printing ink to the object to be printed, by bringing said carrier and the object into mutual contact and by pressing-on said carrier, by means of supplementary
5 pressing means, at least partially around the object to be printed.

By using a flexible carrier, it is obtained that the carrier easily can assume the shape of the surface to be
10 printed and, by moreover applying supplementary pressing means therewith, a complete pressing-on can be guaranteed.

Preferably, for the supplementary pressing means use is
15 made of a fluid pressure, more particularly air pressure, with which a pressure is exerted on the side of the carrier which is opposite to the side which is brought into contact with the object to be printed.

20 According to another possibility, supplementary pressing means of mechanical nature are applied, such as a counterform of the object to be printed, with which the carrier can be pressed against the object.

25 In the most preferred form of embodiment, the aforementioned two kinds of pressing means will be combined, which, in the first place, is useful when printing the front side of a portable telephone. By this combination, it is achieved that the carrier can be pressed into
30 small, relatively deep indentations by means of the counterform, whereas by the pressing, realized by means of the compressed air, on one hand, always a perfect pressing over the entire surface to be printed is guaranteed, whereas, on the other hand, also the bent
35 lateral edges of the object can be printed which are difficult to reach by means of a counterform.

In a preferred form of embodiment, the image to be printed is applied on the carrier in two-dimensional condition and then, by deformation of the carrier, printed on the object in three-dimensional condition.

5 This technique allows for that the application of the image which can consist of a figure as well as of an even coating of one and the same colour or similar, can easily be realized.

10 In a practical form of embodiment, the carrier will be stretched at least during the application of the printing ink, in such a manner that during the application a flat substructure is offered. According to a variant, however, it is not excluded to provide a support surface under
15 this carrier during the application of the printing ink, whether or not combined with the stretching of the carrier.

Preferably, the carrier will also be stretched during the
20 actual printing, for example, by pressing the object to be printed over a well-defined distance into the plane of the carrier.

More particularly, it is preferred that the carrier
25 during the application of the printing ink and the actual printing is stretched in opposite direction, whereby it is displaced over approximately the same distance, and even better is displaced in such a manner that approximately the same extension at the location of the
30 printed image takes place, with the advantage that there is almost no size difference between the image applied on the carrier and the printed image.

Practically, a carrier will be applied showing a contact
35 surface consisting of a colour- or ink-repellent material. According to a particular characteristic of the

invention, to this aim use will be made of a silicone mat or a flexible layer of material based on silicones. Such material offers the advantage that it is very flexible and at the same time will easily release the printing ink during printing.

According to a particular aspect of the invention, the printing ink is provided on the support by means of a printer. As a result of this, forming different images and rapidly switching over from one image to the other is rendered very easy, simply by controlling the printer.

The invention also relates to a device for realizing the aforementioned method, with as a characteristic that it at least consists of a carrier of a flexible layer-shaped material; means for applying printing ink on the carrier; means for transferring the printing ink to the object to be printed, said means consisting of a displacement mechanism for bringing said carrier and the object into mutual contact; and supplementary pressing means which cooperate with the carrier and allow to press on the latter, at least partially around the object to be printed.

With the intention of better showing the characteristics according to the invention, hereafter, as an example without any limitative character, a preferred form of embodiment is described, with reference to the accompanying drawings, wherein:

figure 1 schematically represents a device according to the invention;
figure 2 represents a cross-section according to line II-II in figure 1;
figures 3 and 4 represent the device of figure 1 in two other positions;

figure 5, at a larger scale, represents the part indicated by F5 in figure 4.

As represented in the figures, the device 1 of the invention substantially consists of a carrier 2 of a flexible layer-shaped material; means 3 for applying printing ink on the carrier 2; means 4 for transferring the printing ink to the object 5 to be printed, in this case the front part of a GSM device; and supplementary pressing means 6 which cooperate with the carrier 2 and allow to press on the latter, at least partially around the object 5 to be printed.

The carrier 2 consists of a colour- or ink-repellent material, more particularly a mat which is held at its circumference, in this case by being clamped at its circumference, by means of bolts 7, in a framing 8. In the example, the carrier 2 in the condition of figure 1 is not or almost not stretched.

According to the invention, this carrier 2 preferably consists of a silicone mat. Particularly good results can be obtained with a mat having, in un-stretched condition, a thickness of 1 to 3 mm, and preferably 2 mm.

The means 3 for applying the printing ink on the carrier 2 substantially consist of a printer 9 which can be controlled in a suitable manner, either by means of a suitable software package, or by means of a not represented computer unit.

This printer 9, in its turn, can show a classic construction and substantially consists of a printing head 10, with which preferably several colours can be printed, and driving means for moving the printing head 10, on one hand, along one or more longitudinal guides 11 and, on

the other hand, one or more transversal guides 12.

Further, the device 1 comprises means 13 for presenting the object to be printed which, in the represented example, consist of a holder 14 with which the object 5 is held, and a driving cylinder 15 for moving the holder 14 up and down. According to a not represented variant, these means 13 may also consist of a robot arm which takes up the objects 5 to be printed one after the other and presents them to the device 1.

The means 4 for transferring the printing ink to the object to be printed, form a part of displacement means which allow to move the carrier 2 and/or the means 3 and/or the means 13 in respect to each other, in order to bring them, on one hand, into a first position, whereby the carrier 2 cooperates with the means 3 for applying the printing ink, and, on the other hand, into a second position whereby the carrier 2 cooperates with the object 5, in such a manner as will be further explained in the following.

Said supplementary pressing means 6 consist in the represented example of a pressure chamber 16, more particularly a compressed air chamber, which cooperates with the side 17 of the carrier 2 which is opposite to the side 18 which is brought into contact with the object 5 to be printed, as well as of a counterform 19 with which the carrier 2 can be pressed against the object 5 to be printed or at least is forced to take the the shape of the object 5 to be printed to a minor or major extent.

The pressure chamber 16 consists of a casing 20 which is closed off at the upper side by means of the carrier 2. This casing 20, by means of a conduit 21, can be set under pressure, depressurized, respectively. In the

represented example, the counterform 19 is mounted fixedly in the pressure chamber 16.

In the represented example, said displacement means
5 comprise, on one hand, the already mentioned driving
cylinder 15 for displacing an object 5 carried thereby
and, on the other hand, a driving cylinder 22 for
displacing the pressure chamber 16 between a position
under the printer 9, as represented in figures 1 to 3,
10 and a position under the driving cylinder 15, as
represented in figure 4.

The device is also provided with means 23 for stretching
the carrier 2 during the application of the printing ink
15 on this carrier 2, consisting of a frame 24 in the shape
of a rectangular framing, which can cooperate with the
underside of the carrier 2, more particularly can be
moved up and down between a position whereby the frame
24, as represented in figure 1, is located freely under
20 the carrier 2, and a position whereby the frame 24, as
represented in figure 3, is moved upward, as a result of
which the carrier 2 is stretched and tensioned. The
movement of the frame 24 is performed by means of driving
cylinders 25.

25 The whole is controlled by means of a control unit 26
which may consist of a computer or similar. The driving
cylinders 15, 22, and 25 are fed by means of a compressed
air supply 27 and are controlled by means of valves 28
30 which, in a suitable manner, according to the working
cycle explained in the following, are actuated by means
of the control unit 26.

Figure 1 shows the non-operated condition. From this non-
35 operated condition, the driving cylinders 25 are
actuated, as a result of which the frame 24 is brought up

into the position of figure 3 which is such that the carrier 2 then is positioned precisely under the printing head 10, in stretched condition.

5 Subsequently, the printer 9 is controlled, in such a manner that printing ink 29 is deposited on the carrier 2, whereby the image to be printed is formed. Hereby, this may either relate to an image representing a picture, or to an image simply consisting of a quantity
10 of printing ink of the same colour, preferably in the shape of the object 5 to be printed.

It is noted that the term printing ink has to be interpreted broadly and that, according to the invention,
15 any material has to be subsumed thereunder with which a coating can be realized, thus, an actual ink as well as a paint, varnish or any other material.

After the image has been formed on the carrier 2, the
20 frame 24 is lowered again and the pressure chamber 16 is moved up into a position whereby this latter is positioned with the counterform 19 under the object 5. By subsequently moving the object 5 downward, by means of the driving cylinder 15, and pressing it against the
25 counterform 19 and also feeding compressed air into the pressure chamber 16, a condition is obtained as represented in figures 4 and 5. In this condition, the carrier 2, on one hand, due to the presence of the counterform 19, and, on the other hand, due to the
30 pressure P in the pressure chamber 16, perfectly fits against the object 5 to be printed, as a result of which the printing ink 29 of the image is adequately transferred to the object 5. The protrusions 30 of the counterform 19 hereby penetrate into the seats 31 for the
35 telephone push-buttons.

For pressing-on the carrier 2, in the pressure chamber 16 preferably only a rather low pressure is applied, of less than 100 and even better of 50 to 60 gram/cm².

5 Finally, the object 5 can be moved upward again and subsequently be transported off, after which the cycle can be repeated with a successive object 5.

10 It is noted that the distance A over which the carrier 2 is moved in figure 3 preferably almost coincides with the distance B over which this carrier 2 is moved in figure 4, in such a manner that an almost equal extension of the material of the carrier 2 at the location of the object 5 is obtained.

15

Possibly, the device 1 can be equipped with a cleaning mechanism, which may or may not work automatically, in order to remove inconvenient ink remainders from the carrier 2.

20

It is obvious that different variants are possible. So, for example, instead of attaching the framing 8 by means of bolts 7, this framing 8 can be equipped with an easy to handle stretching mechanism.

25

30 The movement cycle also does not necessarily have to be performed precisely such as represented in the figures. So, for example, it is not excluded to mount the pressure chamber 16 in a fixed manner and to install the means 13 above the printer 9, whereby the printing head 10 is moved sideways at the moment when the object 5 is brought into contact with the carrier 2.

35 According to a particular variant, the counterform 19 is positioned precisely under the carrier 2, whereby this is possible for the position of figure 1 as well as for the

one of figure 3.

It is noted that the invention also relates to methods and devices whereby for the supplementary pressing means, either use is made exclusively of fluid pressure, or use is made exclusively of mechanical pressing means. It is also not excluded to use a liquid for the fluid pressure instead of a gas.

The present invention is in no way limited to the form of embodiment described by way of example and represented in the figures, on the contrary may such method and device for printing objects be realized according to different variants, without leaving the scope of the invention.

Claims.

1.- Method for printing objects, characterized in that it
5 at least consists in, on one hand, applying printing ink
(29) on a carrier (2) consisting of a flexible layer-
shaped material and, on the other hand, transferring the
printing ink (29) to the object (5) to be printed, by
bringing said carrier (2) and the object (5) in mutual
10 contact and by pressing-on said carrier, by means of
supplementary pressing means (6), at least partially
around the object (5) to be printed.

2.- Method according to claim 1, characterized in that
15 for the supplementary pressing means (6), at least use is
made of a fluid pressure, more particularly air pressure,
with which a pressure is exerted upon the side (17) of
the carrier (2) which is opposite to the side (18) which
is brought into contact with the object (5) to be
20 printed.

3.- Method according to claim 2, characterized in that an
air pressure is applied of less than 100 and even better
of 50 to 60 grams/cm².

25 4.- Method according to any of the preceding claims,
characterized in that for the supplementary pressing
means (6), at least use is made of mechanical pressing
means, and preferably of a combination of mechanical
30 pressing means with a pressing by means of fluid
pressure.

5.- Method according to claim 4, characterized in that
the carrier (2) is forced into contact with the object
35 (5) by means of a counterform (19) of the object (5) to
be printed.

6.- Method according to any of the preceding claims, characterized in that it is applied for printing three-dimensional objects (5), whereby the image to be printed is applied on the carrier (2) in two-dimensional condition and, by deformation of the carrier (2), is
5 printed on the object (5) in three-dimensional condition.

7.- Method according to any of the preceding claims, characterized in that the carrier (2), at least during
10 the application of the printing ink (29) thereupon, is stretched.

8.- Method according to any of the preceding claims, characterized in that the carrier (2), at least during
15 the actual printing, is stretched.

9.- Method according to claim 8, characterized in that the carrier (2) is stretched during printing by pressing the object (5) to be printed over a well-determined
20 distance (B) into the plane of the carrier (2).

10.- Method according to one or more of the preceding claims, characterized in that the carrier (2) during the application of the printing ink (29) and the actual
25 printing is stretched in opposite direction, whereby it is displaced over approximately the same distance (A-B), and even better is displaced in such a manner that approximately the same extension takes place at the location of the image to be printed.

30 11.- Method according to any of the preceding claims, characterized in that use is made of a carrier (2) with a contact surface consisting of a colour- or ink-repellent material.

35 12.- Method according to claim 11, characterized in that

the carrier (2) consists of a silicone mat.

13.- Method according to any of the preceding claims,
characterized in that the printing ink (29) is applied on
5 the carrier (2) by means of a printer (9).

14.- Method according to any of the preceding claims,
characterized in that it is applied for printing a casing
10 (20) of portable telephones.

15.- Device for realizing the method of any of the
preceding claims, characterized in that it at least
consists of a carrier (2) of a flexible layer-shaped
material; means (3) for applying printing ink (29) on the
15 carrier (2); means (4) for transferring the printing ink
(29) to the object (5) to be printed; and supplementary
pressing means (6) which cooperate with the carrier (2)
and allow to press on the latter, at least partially
around the object (5) to be printed.

20 16.- Device according to claim 15, characterized in that
the carrier (2) consists of a colour- or ink repellent
mat which is held at its circumference.

25 17.- Device according to claim 15 or 16, characterized in
that the supplementary pressing means (6) at least
consist of a pressure chamber (16), more particularly an
air pressure chamber, which cooperates with the side (17)
of the carrier (2) which is opposite to the side (18)
30 which is brought into contact with the object (5) to be
printed.

18.- Device according to any of the claims 15 to 17,
characterized in that the supplementary pressing means
35 (6) at least consist of a counterform (19) with which the
carrier (2) can be pressed against the object (5) to be

printed.

19.- Device according to claims 17 and 18, characterized
in that the counterform (19) is located in the pressure
5 chamber (16).

20.- Device according to any of the claims 15 to 16,
characterized in that it is provided with means (23) for
stretching the carrier (2) during the application of the
10 printing ink (29) on the carrier (2), consisting of a
frame (24) which can cooperate with the carrier (2), more
particularly, can be displaced in respect to said carrier
(2).

21.- Device according to any of the claims 15 to 20,
characterized in that the means (3) for applying the
printing ink (29) on the carrier (2) consist of a printer
15 (9) which can be moved over the carrier (2).

22.- Device according to any of the claims 15 to 21,
characterized in that it comprises means (13) for
presenting the object (5) to be printed, as well as means
which allow to move the carrier (2) and/or the means (3)
for applying the printing ink (29) on the carrier (2)
25 and/or the means (13) for presenting the object (5) to be
printed in respect to each other, in order to bring them,
on one hand, into a first position whereby the carrier
(2) cooperates with the means (3) for applying the
printing ink (29) and, on the other hand, into a second
30 position whereby the carrier (2) cooperates with the
object (5) to be printed.

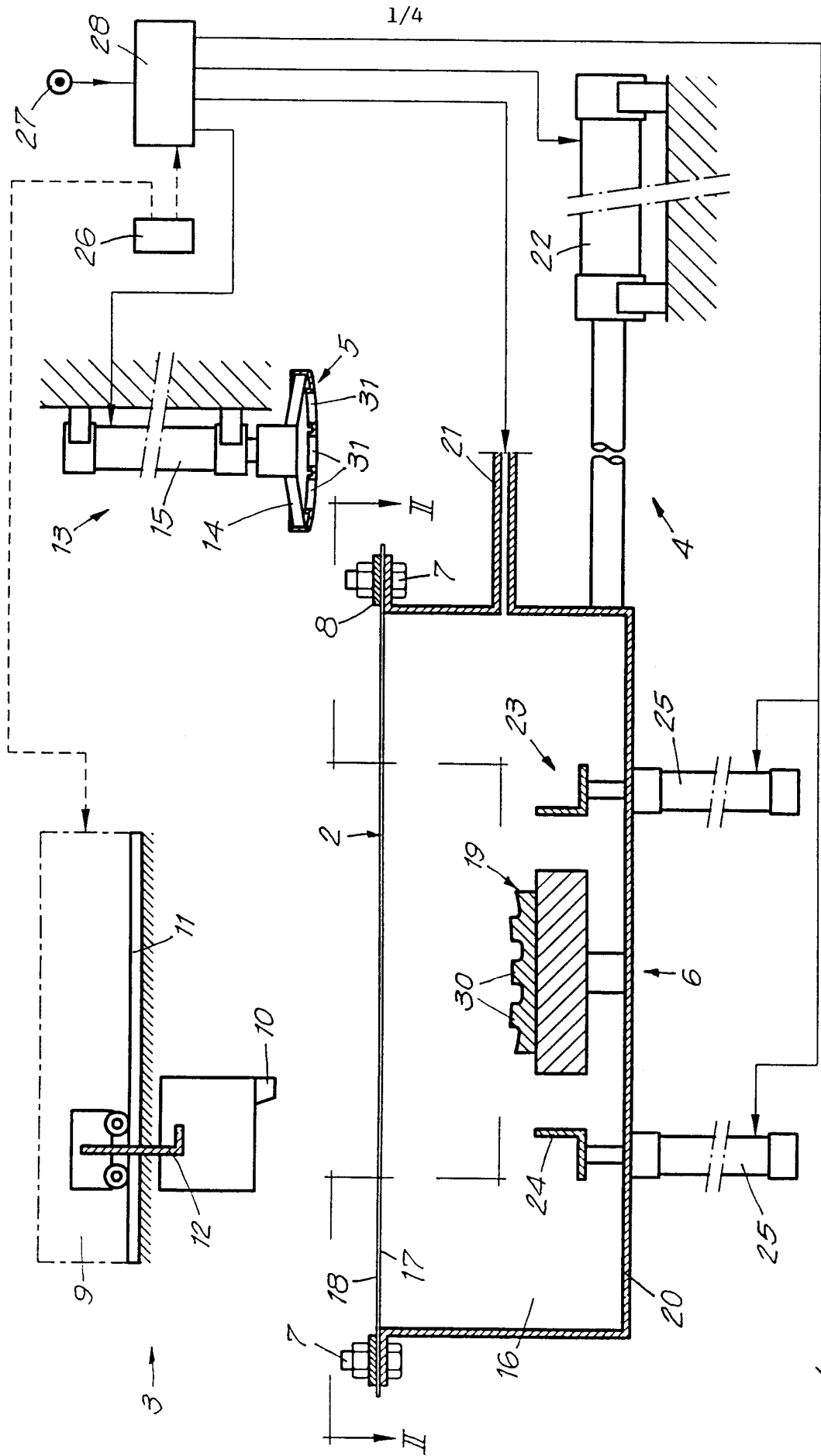

Fig. 1

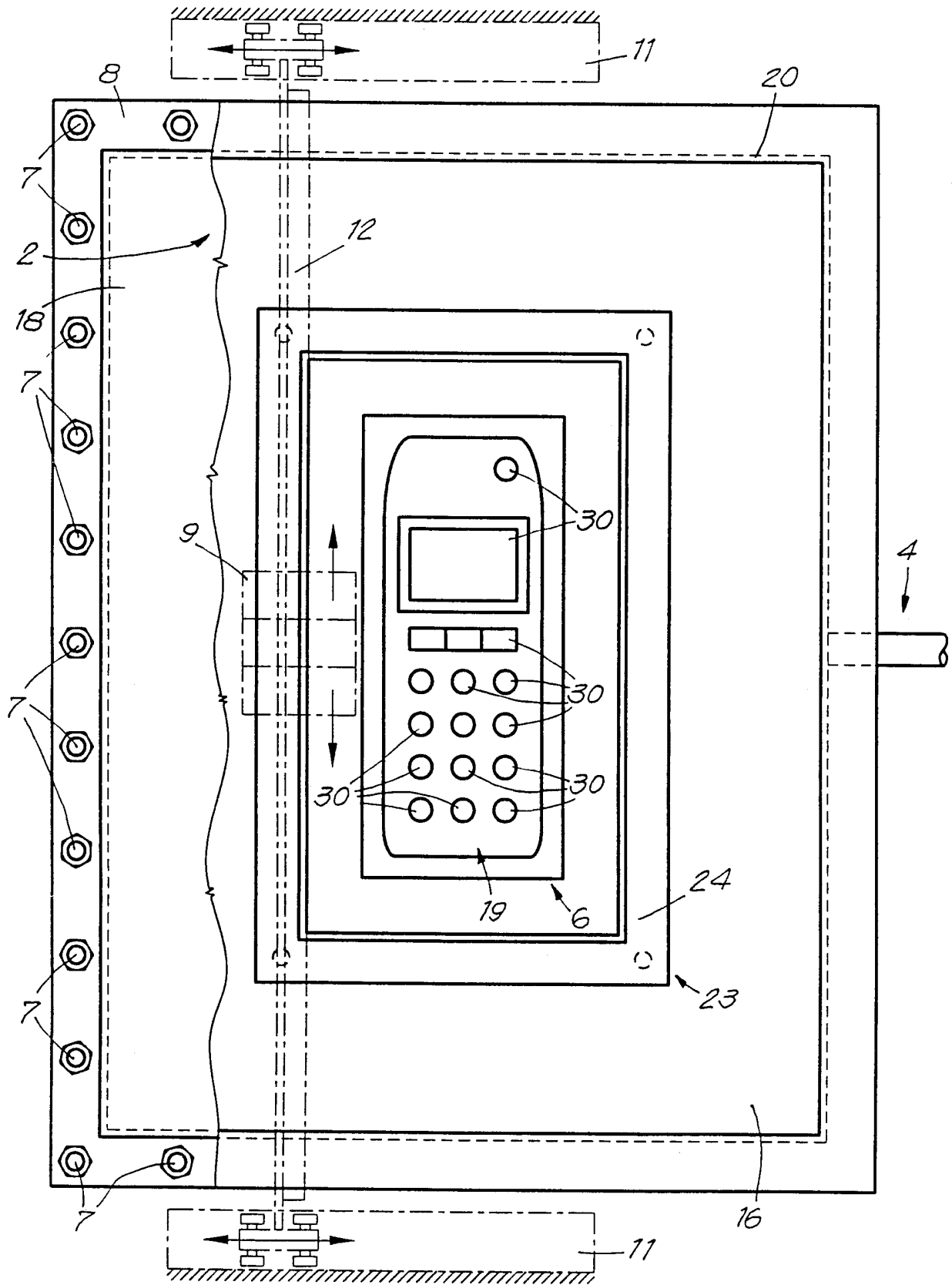

Fig. 2

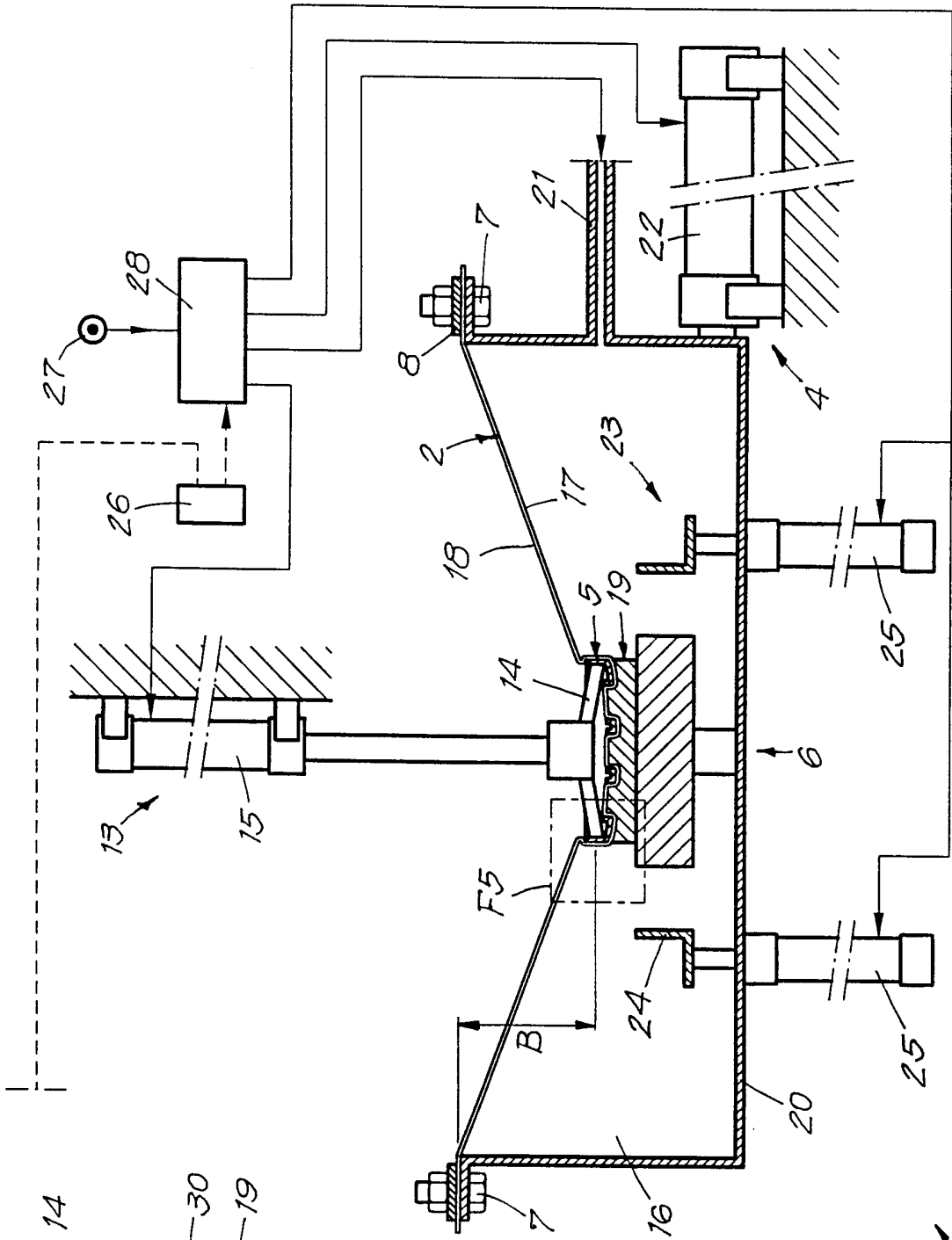

Fig. 4

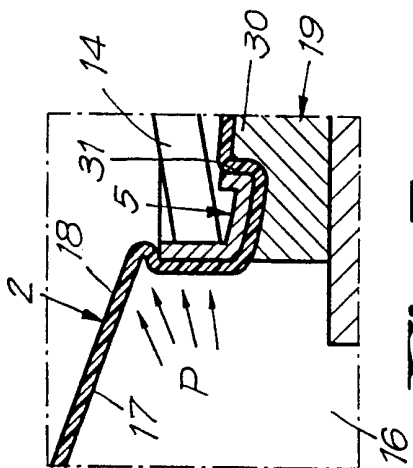

Fig. 5

INTERNATIONAL SEARCH REPORT

International Application No

PCT/BE 00/00029

A. CLASSIFICATION OF SUBJECT MATTER
 IPC 7 B41M5/035

According to International Patent Classification (IPC) or to both national classification and IPC

B. FIELDS SEARCHED

Minimum documentation searched (classification system followed by classification symbols)
 IPC 7 B41M B44C

Documentation searched other than minimum documentation to the extent that such documents are included in the fields searched

Electronic data base consulted during the international search (name of data base and, where practical, search terms used)

PAJ, WPI Data, EPO-Internal

C. DOCUMENTS CONSIDERED TO BE RELEVANT

Category °	Citation of document, with indication, where appropriate, of the relevant passages	Relevant to claim No.
X	EP 0 110 220 A (ROEHM GMBH) 13 June 1984 (1984-06-13) page 6, line 10 -page 8, line 6	1, 15
X	PATENT ABSTRACTS OF JAPAN vol. 006, no. 124 (M-141), 9 July 1982 (1982-07-09) & JP 57 051488 A (YASUDA YOICHI), 26 March 1982 (1982-03-26) abstract	1, 15
X	PATENT ABSTRACTS OF JAPAN vol. 1999, no. 04, 30 April 1999 (1999-04-30) & JP 11 010997 A (HIROTA KINJI;FUJITA YOSHIHARU), 19 January 1999 (1999-01-19) abstract	1, 15

Further documents are listed in the continuation of box C.

Patent family members are listed in annex.

° Special categories of cited documents :

- *A* document defining the general state of the art which is not considered to be of particular relevance
- *E* earlier document but published on or after the international filing date
- *L* document which may throw doubts on priority claim(s) or which is cited to establish the publication date of another citation or other special reason (as specified)
- *O* document referring to an oral disclosure, use, exhibition or other means
- *P* document published prior to the international filing date but later than the priority date claimed

- *T* later document published after the international filing date or priority date and not in conflict with the application but cited to understand the principle or theory underlying the invention
- *X* document of particular relevance; the claimed invention cannot be considered novel or cannot be considered to involve an inventive step when the document is taken alone
- *Y* document of particular relevance; the claimed invention cannot be considered to involve an inventive step when the document is combined with one or more other such documents, such combination being obvious to a person skilled in the art.
- *&* document member of the same patent family

Date of the actual completion of the international search

2 August 2000

Date of mailing of the international search report

09/08/2000

Name and mailing address of the ISA

European Patent Office, P.B. 5818 Patentlaan 2
 NL - 2280 HV Rijswijk
 Tel. (+31-70) 340-2040, Tx. 31 651 epo nl,
 Fax: (+31-70) 340-3016

Authorized officer

Herrmann, J

INTERNATIONAL SEARCH REPORT

Information on patent family members

International Application No

PCT/BE 00/00029

Patent document cited in search report	Publication date	Patent family member(s)	Publication date
EP 0110220 A	13-06-1984	DE 3244355 A DE 3310432 A AT 36672 T CA 1211256 A DE 3377781 D JP 1781682 C JP 3036028 B JP 59101397 A US 4664672 A	07-06-1984 27-09-1984 15-09-1988 16-09-1986 29-09-1988 13-08-1993 30-05-1991 11-06-1984 12-05-1987
JP 57051488 A	26-03-1982	NONE	
JP 11010997 A	19-01-1999	NONE	