



(11) **EP 4 445 757 A1**

(12) **EUROPEAN PATENT APPLICATION**
published in accordance with Art. 153(4) EPC

(43) Date of publication:
16.10.2024 Bulletin 2024/42

(21) Application number: **23791989.9**

(22) Date of filing: **03.02.2023**

(51) International Patent Classification (IPC):
A24D 3/06 ^(2006.01) **A24D 3/10** ^(2006.01)
A24D 3/08 ^(2006.01) **A24D 3/14** ^(2006.01)
A24D 3/02 ^(2006.01)

(52) Cooperative Patent Classification (CPC):
A24D 3/02; A24D 3/06; A24D 3/08; A24D 3/10;
A24D 3/14

(86) International application number:
PCT/KR2023/001567

(87) International publication number:
WO 2023/204406 (26.10.2023 Gazette 2023/43)

(84) Designated Contracting States:
AL AT BE BG CH CY CZ DE DK EE ES FI FR GB
GR HR HU IE IS IT LI LT LU LV MC ME MK MT NL
NO PL PT RO RS SE SI SK SM TR

Designated Extension States:
BA

Designated Validation States:
KH MA MD TN

(30) Priority: **21.04.2022 KR 20220049268**

(71) Applicants:

- **KT&G Corporation**
Daedeok-gu
Daejeon 34337 (KR)
- **Kolon Industries, Inc.**
Seoul 07793 (KR)

(72) Inventors:

- **HA, Sung Hoon**
Daejeon 34128 (KR)
- **MA, Kyeng Bae**
Daejeon 34128 (KR)

- **YANG, Jin Chul**
Daejeon 34128 (KR)
- **CHEONG, Bong Su**
Daejeon 34128 (KR)
- **JU, So Yeong**
Daejeon 34128 (KR)
- **SEO, Seung Dong**
Gumi-si, Gyeongsangbuk-do 39366 (KR)
- **LEE, Jeong Hun**
Gumi-si, Gyeongsangbuk-do 39366 (KR)
- **JEONG, Jong Cheol**
Gumi-si, Gyeongsangbuk-do 39366 (KR)
- **JIN, Sang Woo**
Gumi-si, Gyeongsangbuk-do 39366 (KR)
- **HWANG, Yeong Nam**
Gumi-si, Gyeongsangbuk-do 39366 (KR)

(74) Representative: **Ter Meer Steinmeister & Partner**
Patentanwälte mbB
Nymphenburger Straße 4
80335 München (DE)

(54) **FILTER HAVING APPLIED THERETO FUNCTIONALITY-ENHANCED BINDER AND SMOKING ARTICLE INCLUDING SAME**

(57) The present disclosure provides a smoking article filter including lyocell tow including a plurality of lyocell fibers, a phenolic functional material, and a binder

and a method of producing the smoking article filter and provides a smoking article including the smoking article filter.

FIG. 1

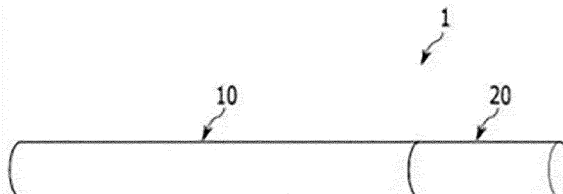

EP 4 445 757 A1

Description

[Technical Field]

5 **[0001]** The present disclosure relates to a filter to which a binder with improved functionality is applied and a smoking article including the same.

[Background Art]

10 **[0002]** Lyocell contains cellulose as its main component, and a plasticizer harmless to the human body is hardly present in lyocell, unlike in cellulose acetate (CA). For this reason, a binder solution should be used to produce a filter using lyocell and impart a certain level of hardness or higher to the filter. In a case in which materials such as triethyl citrate (TEC) and triacetin (TA) are mixed together with a conventionally-used binder solution in order to produce a lyocell filter, a layer separation phenomenon occurs in the solution. When such a solution is used, a problem arises in
15 that it is not possible to homogeneously spray the binder solution and the materials such as TEC and TA on lyocell tow.

[Disclosure]

[Technical Problem]

20 **[0003]** The present disclosure is directed to providing a lyocell filter for smoking articles that is produced by homogeneously mixing a binder and materials such as triethyl citrate (TEC) and/or triacetin (TA) with lyocell fibers and a smoking article including the lyocell filter.

25 **[0004]** However, objectives to be achieved by the present disclosure are not limited to that mentioned above, and other unmentioned objectives should be clearly understood by those of ordinary skill in the art from the description below.

[Technical Solution]

30 **[0005]** One aspect of the present disclosure provides a smoking article filter including lyocell tow including a plurality of lyocell fibers, a phenolic functional material, and a binder.

35 **[0006]** Another aspect of the present disclosure provides a smoking article including a tobacco medium portion and a filter portion, wherein the filter portion includes lyocell tow including a plurality of lyocell fibers, a phenolic functional material, an amphoteric binder, and an alcohol, the phenolic functional material is one or more selected from the group consisting of triethyl citrate (TEC) and triacetin (TA), and the amphoteric binder is one or more selected from the group consisting of a cellulose-based binder and a vinyl-based binder.

40 **[0007]** Still another aspect of the present disclosure provides a method of producing a smoking article filter, the method including: a) preparing lyocell tow including a bundle of a plurality of lyocell fibers; b) mixing an amphoteric binder and an alcohol and then mixing a phenolic functional material therewith; and c) dispersing a solution, which is obtained by the mixing, in the lyocell tow, wherein the phenolic functional material is one or more selected from the group consisting of triethyl citrate (TEC) and triacetin (TA), the amphoteric binder is one or more selected from the group consisting of a cellulose-based binder and a vinyl-based binder, and the alcohol is propylene glycol (PG).

[Advantageous Effects]

45 **[0008]** According to one aspect of the present disclosure, it is possible to provide a lyocell filter in which materials such as triethyl citrate (TEC) and/or triacetin (TA), which are fat-soluble, are more homogeneously mixed, and in this way, there is an advantage that components such as phenols that are present in cigarette smoke can be more effectively removed during smoking. Also, an eco-friendly filter can be produced using lyocell tow.

50 **[0009]** Advantageous effects of the present disclosure are not limited to those mentioned above and should be understood as including all advantageous effects inferable from the detailed description of the present disclosure or the configuration of the disclosure stated in the claims.

[Description of Drawings]

55 **[0010]**

FIG. 1 is a view illustrating a schematic configuration of a smoking article according to one embodiment of the present disclosure.

FIG. 2 is a view illustrating a schematic configuration of a smoking article including a wrapper according to one embodiment of the present disclosure.

[Modes of the Invention]

5

[0011] Hereinafter, embodiments will be described in detail with reference to the accompanying drawings. However, various changes may be made to the embodiments, and thus, the scope of rights of the application is not limited or restricted by the embodiments. All changes, equivalents, or substitutes relating to the embodiments should be understood as belonging to the scope of rights of the application.

10 **[0012]** Terms used in the embodiments are used for description purposes only and should not be construed as limiting. A singular expression includes a plural expression unless the context clearly indicates otherwise. In the application, terms such as "include" or "have" should be understood as indicating the presence of features, numbers, steps, operations, elements, parts, or combinations thereof and not excluding the possibility of the presence or addition of one or more other features, numbers, steps, operations, elements, parts, or combinations thereof in advance.

15 **[0013]** Unless otherwise defined, all terms including technical or scientific terms used herein have the same meaning as commonly understood by one of ordinary skill in the art to which the embodiments pertain. Terms, such as those defined in commonly used dictionaries, should be construed as having a meaning that is consistent with their meaning in the context of the relevant art and are not to be construed in an idealized or overly formal sense unless expressly so defined herein.

20 **[0014]** Also, in giving descriptions with reference to the accompanying drawings, the same reference numerals are assigned to the same components wherever possible even when the components are illustrated in different drawings, and repeated description thereof will be omitted. In describing the embodiments, when detailed description of a known related art is determined as having the possibility of unnecessarily obscuring the gist of the embodiments, the detailed description thereof will be omitted.

25 **[0015]** Also, in describing components of the embodiments, terms such as first, second, A, B, (a), and (b) may be used. Such terms are only for distinguishing one component from another component, and the essence, order, sequence, or the like of the corresponding component is not limited by the terms.

30 **[0016]** A component including a common function with a component included in any one embodiment will be described using the same name in another embodiment. Unless the context clearly indicates otherwise, description made in any one embodiment may apply to another embodiment and detailed description will be omitted in a repeated range.

[0017] In this specification, a "smoking article" may refer to anything capable of generating an aerosol, such as tobacco (cigarette) and cigars. The smoking article may include an aerosol-generating material or an aerosol-forming substrate. Also, the smoking article may include a solid material based on tobacco raw materials, such as reconstituted tobacco leaves, cut tobacco leaves, and reconstituted tobacco. A smoking material may include a volatile compound.

35 **[0018]** Also, in this specification, "upstream" or "upstream direction" refers to a direction moving away from an oral region of a user smoking a smoking article 1, and "downstream" or "downstream direction" refers to a direction approaching the oral region of the user smoking the smoking article 1. For example, in the smoking article 1 illustrated in FIG. 1, a tobacco material portion 10 is disposed upstream or in an upstream direction of a cigarette filter portion 20.

40 **[0019]** Further, in the specification, a case in which the smoking article 1 is a combustion-type cigarette is described as an example. However, the present disclosure is not limited thereto, and the smoking article 1 may also be a heating-type cigarette or the like that is used together with an aerosol generation device (not illustrated) such as an electronic cigarette device.

45 **[0020]** One embodiment of the present disclosure provides a smoking article filter including lyocell tow including a plurality of lyocell fibers, the smoking article filter including a binder solution containing a phenolic functional material and a binder.

[0021] The phenolic functional material corresponds to a material that can specifically reduce phenols generated during smoking. For example, the phenolic functional material may be triethyl citrate (TEC) or triacetin (TA) or may be both.

50 **[0022]** In a case in which the TEC or TA is included in the binder solution, the content of the TEC or TA may be 20 to 50 wt%. In a case in which the content is less than 20 wt%, an effect of reducing phenols may be weakened, and in a case in which the content exceeds 50 wt%, the adhesive strength of the binder solution may significantly decrease, and it may be difficult to implement an appropriate filter hardness.

[0023] The type of binder included in the smoking article filter may partially differ according to a method by which the filter is produced, and the binder may correspond to a hydrophilic binder, and/or an amphoteric binder that is both water-soluble and fat-soluble.

55 **[0024]** In a case in which the smoking article filter includes a hydrophilic binder, when producing the smoking article filter, the hydrophilic binder and the phenolic functional material such as TEC or TA, which is fat-soluble, cannot be easily mixed, and thus a phenomenon in which layers of the solution are separated occurs. Therefore, in this case, it is desirable to additionally add an emulsifier when producing the filter, and accordingly, the produced smoking article filter

further includes an emulsifier.

[0025] For reasons such as smokers' health and environmental friendliness, the type of emulsifier may be an emulsifier for food, and as a specific example, the emulsifier may correspond to a monoglyceride, diglyceride, and/or triglyceride.

[0026] In a case in which the smoking article filter includes an amphoteric binder, an eco-friendly aqueous solution and the fat-soluble phenolic functional material such as TEC or TA, which are used in producing the lyocell filter, can be homogeneously mixed. In this way, the phenolic functional material can be homogeneously dispersed in the lyocell tow, and it is possible to effectively reduce components such as phenols that are present in cigarette smoke during smoking.

[0027] Types of amphoteric binder may include a cellulose-based binder and/or a vinyl-based binder. As a specific example, the cellulose-based binder may be one or more selected from the group consisting of hydroxypropyl methylcellulose (HPMC), ethyl cellulose (EC), methyl cellulose (MC), and carboxymethyl cellulose (CMC), and the vinyl-based binder may be one or more selected from the group consisting of polyvinylpyrrolidone (PVP), polyvinyl alcohol (PVA), and ethylene vinyl acetate (EVAc).

[0028] Meanwhile, including the vinyl-based binder among the types of amphoteric binder may be more desirable, and the vinyl-based binder may be PVP.

[0029] In the case in which PVP is used as the amphoteric binder, compared to when other amphoteric binders are used, the viscosity is low when mixed with the fat-soluble phenolic functional material, and thus the fat-soluble phenolic functional material may be more homogeneously mixed. Further, even when producing the smoking article filter, there is an advantageous effect that it is possible to easily produce a filter in which the phenolic functional material is homogeneously dispersed in the lyocell tow.

[0030] Furthermore, in addition to the binder and the phenolic functional material, an alcohol may be further included and mixed to prevent the growth of microorganisms and fungi in the binder solution. Types of alcohol may include a polyhydric alcohol, a monohydric alcohol such as ethyl alcohol, or a mixture thereof. Propylene glycol (PG), which is a polyhydric alcohol, may be included as the alcohol.

[0031] Meanwhile, in the case in which PG is used, PG serves as a release agent, and a phenomenon in which the lyocell tow is adhered and stuck to the rolls of filter equipment is reduced. As a result, the efficiency of the filter production process is increased.

[0032] In a case in which ethyl alcohol is used as the monohydric alcohol, 5 to 10 wt% thereof may be used, and in a case in which PG is used as the polyhydric alcohol, 20 to 50 wt% thereof may be used.

[0033] In addition, according to the production purposes (use for combustion-type cigarettes, electronic cigarettes, or the like) and needs, the smoking article filter may further include a capsule carrying a flavor therein or further include a moisturizer or the like.

[0034] In the case in which the smoking article filter includes the flavor-carrying capsule, due to effects of providing various flavor experiences and masking an unpleasant smell, the smoker's satisfaction may be increased. By including the moisturizer, vapor production may be more effectively increased as compared to the conventional smoking articles.

[0035] Another aspect of the present disclosure provides a smoking article including a tobacco medium portion and a filter portion, the smoking article including lyocell tow including a plurality of lyocell fibers, a phenolic functional material, an amphoteric binder, and an alcohol, wherein the phenolic functional material is one or more selected from the group consisting of triethyl citrate (TEC) and triacetin (TA), and the amphoteric binder is one or more selected from the group consisting of a cellulose-based binder and a vinyl-based binder.

[0036] Here, the amphoteric binder and the alcohol are substantially the same as the types of amphoteric binder and alcohol included in the smoking article filter, which have been described above, and polyvinylpyrrolidone (PVP) may be included as the amphoteric binder while propylene glycol (PG) is included as the alcohol.

[0037] Meanwhile, the tobacco medium portion typically includes a tobacco material including nicotine such as tobacco leaves and may further include an excipient such as a binder or other additives. As an example, a tobacco medium included in the tobacco medium portion of the present disclosure may be produced in the form of granules including the tobacco material, the excipient, and the like.

[0038] In the present disclosure, the tobacco material is a material forming an aerosol-generating substrate and may be pieces of tobacco leaves, tobacco stems, tobacco powder generated while processing tobacco, and/or strips of tobacco leaves. The tobacco leaves may be at least one or more selected from bright tobacco leaves, burley tobacco leaves, oriental tobacco leaves, cigar tobacco leaves, and toasted tobacco leaves, but the present disclosure is not limited thereto.

[0039] Further, the filter portion of the smoking article according to one embodiment of the present disclosure may be divided into two or more segments. The filter portion may be divided into a first filter portion, a second filter portion, and the like, and as long as one of the two or more segments corresponds to the smoking article filter according to one embodiment of the present disclosure regardless of where the one segment is disposed, the filter portion may be included within the scope of the present disclosure.

[0040] Also, the smoking article may include, in addition to the tobacco medium portion and the filter portion, a wrapper

configured to surround the constituent portions, and the wrapper may be produced using common filter wrapping paper. Also, one or more perforations may be selectively formed in a circumferential direction in a tipping wrapper configured to combine the tobacco medium portion and the filter portion in order to allow outside air to enter or an internal gas to exit. In this way, there are advantageous effects that an air dilution rate of a cigarette can be increased, and the amount of delivered mainstream smoke components can be controlled.

[0041] Hereinafter, the configurations of the present disclosure and the advantageous effects according thereto will be described in more detail using examples and comparative examples. However, the examples are merely for describing the present disclosure in more detail, and the scope of the present disclosure is not limited by the examples.

Examples

1) Method of Producing Lyocell Filter

[0042] Using lyocell fibers each having a size of about 3.0 denier, lyocell tow in which a tow fiber bundle has a size of about 35,000 denier was produced. Also, a binder solution, which is a mixture of a binder, TEC, and a solvent, was prepared. Specifically, the binder solution was prepared by adding 10 wt% polyvinylpyrrolidone (PVP) to a 60 wt% solvent (a solvent in which 40 wt% propylene glycol, 10 wt% ethanol, and 10 wt% water are mixed) and 30 wt% TEC based on the entire weight of the binder solution. The prepared binder solution was sprayed on the lyocell tow through brush spraying. The binder solution was sprayed at 10 or 15 wt% based on the weight of the lyocell tow to produce the lyocell tow including the binder. The produced lyocell tow was dried and then wrapped with wrapping paper to produce a cigarette filter having an axial length of about 108 mm and a circumference of about 24.20 mm.

2) Difference in Viscosity according to Type of Binder

[0043] The inventors of the present disclosure compared differences in viscosity by temperature of PVP which is a vinyl-based binder according to one embodiment of the present disclosure, hydroxypropyl methylcellulose (HPMC) which is a cellulose-based binder, and polyester (refer to Table 1).

[Table 1]

Binder	Concentration (%)	Viscosity (cP)	
		25 °C	40 °C
HPMC	10	400	180
PVP	10	30	10 or lower
Polyester	10	10 or lower	5 or lower

[0044] HPMC which is a cellulose-based binder and PVP which is a vinyl-based binder both correspond to amphoteric binders, and thus both of the binders may be mixed with TEC which is fat-soluble. However, as shown in Table 1 above, HPMC had a higher viscosity during dissolution than PVP and was not homogeneously dispersed in the filter production process, which caused the tow to be adhered to and rolled around a mechanical roll. As a result, problems such as breakage of the tow occurred. On the other hand, PVP had a lower viscosity than HPMC and thus had advantages that a problem did not occur in the filter production process, and the TEC material could be homogeneously dispersed in the lyocell tow.

[0045] Meanwhile, despite having a low viscosity like PVP, polyester could not be homogeneously mixed with TEC which is a phenolic functional material and thus had a limitation in that a surfactant or an emulsifier should be used to homogeneously disperse polyester. In the case in which the surfactant or emulsifier is used (when TEC is dispersed in a polyester binder solution including the surfactant or emulsifier), there is a disadvantage that the viscosity rather increases.

3) Preparation of Polyester Binder Solution and Polyvinylpyrrolidone (PVP) Binder Solution and Confirmation of Effects of Filters to which Binder Solutions are Applied

[0046] A polyester binder, water, propylene glycol (PG), and ethyl alcohol (EtOH) were mixed together to prepare a polyester binder solution, and a PVP binder, water, PG, EtOH, and TEC were mixed together to prepare a PVP binder solution. In the case of polyester, since layer separation occurs when polyester is mixed together with TEC, it is difficult to prepare a homogeneous binder solution. However, in the case of PVP, since PVP is an amphoteric binder and is

mixed well with TEC, a homogeneous binder solution can be easily prepared.

[0047] Lyocell filters to which the two different binder solutions were applied were used to produce cigarettes, the amounts of phenol in the smoke of the cigarettes were measured and compared, and the results are shown in Table 2 below.

[Table 2]

Filter	Phenol ($\mu\text{g}/\text{cig}$)
Lyocell filter (Polyester binder solution)	4.6
Lyocell filter (PVP binder solution)	3.1

[0048] As shown in Table 2 above, it can be confirmed that, compared to when the polyester binder solution is applied to the lyocell filter, the phenol reduction effect is about 30% greater when the PVP binder solution is applied to the lyocell filter.

[0049] The embodiments have been described above using only some drawings, but those of ordinary skill in the art may apply various technical modifications and changes based on the above. For example, appropriate results may be achieved even when operations described herein are performed in a different order from the method described herein, and/or components such as a system, a structure, a device, and a circuit described herein are coupled or combined in different forms from the method described herein or replaced or substituted with other components or their equivalents.

[0050] Therefore, other implementations, other embodiments, and those equivalent to the claims below fall within the scope of the claims.

Claims

1. A smoking article filter comprising:

lyocell tow including a plurality of lyocell fibers; and
a binder solution containing a phenolic functional material and a binder.

2. The smoking article filter of claim 1, wherein the binder solution includes 20 to 50 wt% of the phenolic functional material.

3. The smoking article filter of claim 1, wherein the phenolic functional material is one or more selected from the group consisting of triethyl citrate (TEC) and triacetin (TA).

4. The smoking article filter of claim 1, wherein the binder is one or more selected from the group consisting of a hydrophilic binder and an amphoteric binder.

5. The smoking article filter of claim 1, wherein:

the binder is one or more hydrophilic binders selected from the group consisting of polyester and a starch-based material; and
the smoking article filter further comprises an emulsifier.

6. The smoking article filter of claim 5, wherein the emulsifier is at least one or more selected from the group consisting of a monoglyceride, diglyceride, and triglyceride.

7. The smoking article filter of claim 1, wherein:

the binder is one or more amphoteric binders selected from the group consisting of a cellulose-based binder and a vinyl-based binder;
the cellulose-based binder is one or more selected from the group consisting of hydroxypropyl methylcellulose (HPMC), ethyl cellulose (EC), methyl cellulose (MC), and carboxymethyl cellulose (CMC); and
the vinyl-based binder is one or more selected from the group consisting of polyvinylpyrrolidone (PVP), polyvinyl alcohol (PVA), and ethylene vinyl acetate (EVAc).

8. The smoking article filter of claim 1, wherein the binder is one or more vinyl-based binders selected from the group consisting of polyvinylpyrrolidone (PVP), polyvinyl alcohol (PVA), and ethylene vinyl acetate (EVAc).

9. The smoking article filter of claim 1, wherein the binder is polyvinylpyrrolidone (PVP).

10. The smoking article filter of claim 4, further comprising an alcohol.

11. The smoking article filter of claim 10, wherein the alcohol is propylene glycol (PG).

12. A smoking article comprising:

a tobacco medium portion; and
a filter portion,

wherein the filter portion includes lyocell tow including a plurality of lyocell fibers, a phenolic functional material, an amphoteric binder, and an alcohol, the phenolic functional material is one or more selected from the group consisting of triethyl citrate (TEC) and triacetin (TA), and the amphoteric binder is one or more selected from the group consisting of a cellulose-based binder and a vinyl-based binder.

13. The smoking article of claim 12, wherein the amphoteric binder is one or more vinyl-based binders selected from the group consisting of polyvinylpyrrolidone (PVP), polyvinyl alcohol (PVA), and ethylene vinyl acetate (EVAc).

14. The smoking article of claim 12, wherein the amphoteric binder is polyvinylpyrrolidone (PVP).

15. The smoking article of claim 12, wherein the alcohol is propylene glycol (PG).

16. A method of producing a smoking article filter, the method comprising:

a) preparing lyocell tow including a bundle of a plurality of lyocell fibers;
b) mixing an amphoteric binder and an alcohol and then mixing a phenolic functional material therewith; and
c) dispersing a solution, which is obtained by the mixing, in the lyocell tow, wherein the phenolic functional material is one or more selected from the group consisting of triethyl citrate (TEC) and triacetin (TA), the amphoteric binder is one or more selected from the group consisting of a cellulose-based binder and a vinyl-based binder, and the alcohol is propylene glycol (PG).

FIG. 1

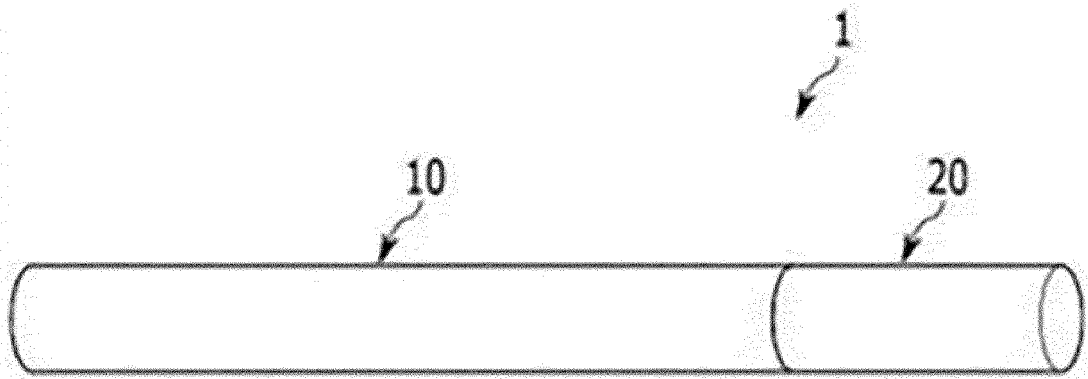
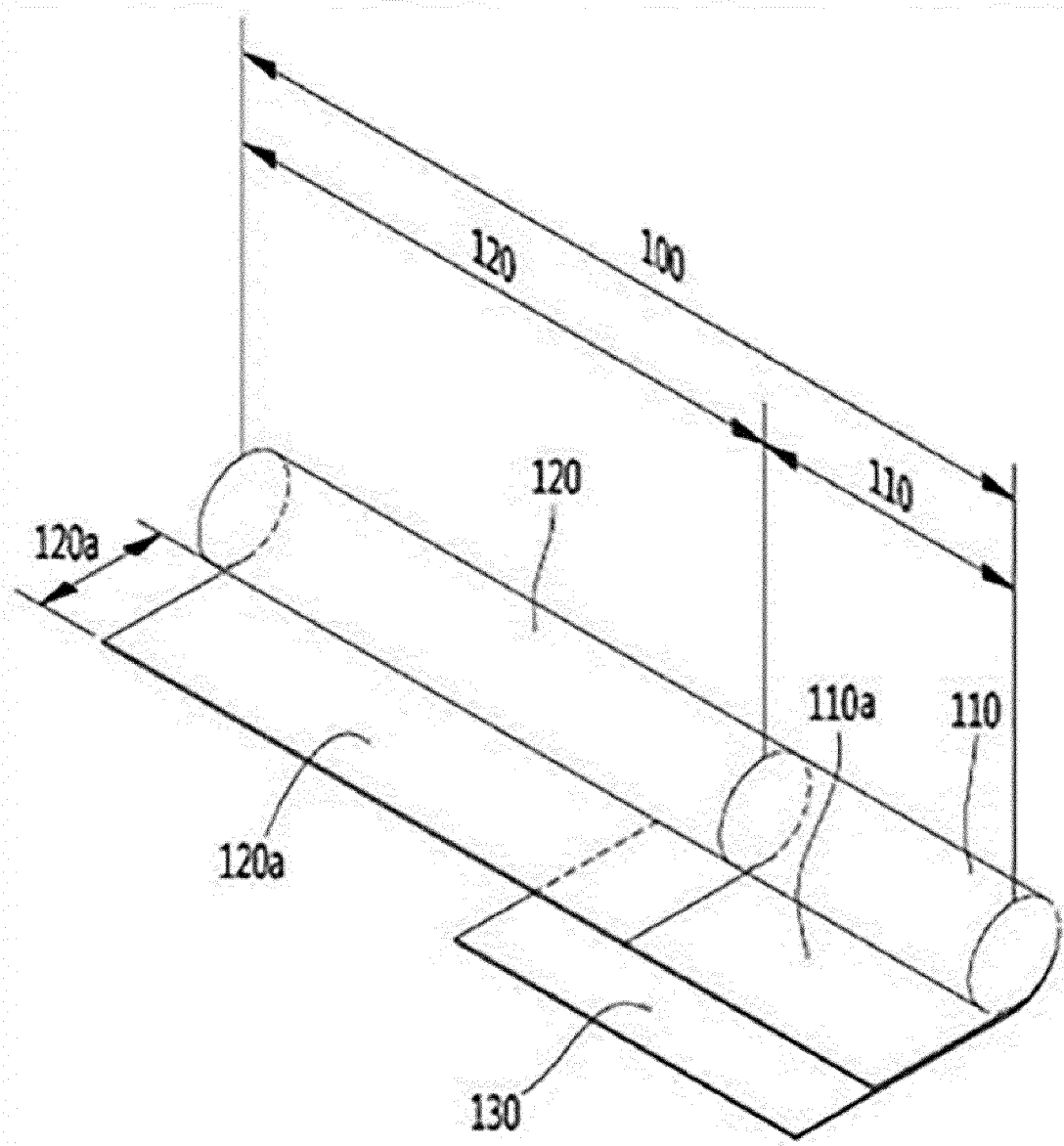

FIG. 2



INTERNATIONAL SEARCH REPORT

International application No.
PCT/KR2023/001567

5
10
15
20
25
30
35
40
45
50
55

A. CLASSIFICATION OF SUBJECT MATTER	
A24D 3/06(2006.01)i; A24D 3/10(2006.01)i; A24D 3/08(2006.01)i; A24D 3/14(2006.01)i; A24D 3/02(2006.01)i	
According to International Patent Classification (IPC) or to both national classification and IPC	
B. FIELDS SEARCHED	
Minimum documentation searched (classification system followed by classification symbols) A24D 3/06(2006.01); A24B 15/24(2006.01); A24D 1/02(2006.01); A24D 1/04(2006.01); A24D 3/02(2006.01); A24D 3/10(2006.01); A24D 3/14(2006.01); A24F 47/00(2006.01)	
Documentation searched other than minimum documentation to the extent that such documents are included in the fields searched Korean utility models and applications for utility models: IPC as above Japanese utility models and applications for utility models: IPC as above	
Electronic data base consulted during the international search (name of data base and, where practicable, search terms used) eKOMPASS (KIPO internal) & keywords: 필터(filter), 라이오셀(lyocell), 트리에틸시트레이트(triethyl citrate), 트리아세틴(triacetin), 글리세라이드(glyceride), 폴리비닐피롤리돈(polyvinylpyrrolidone)	
C. DOCUMENTS CONSIDERED TO BE RELEVANT	
Category*	Citation of document, with indication, where appropriate, of the relevant passages
X	WO 2022-018180 A1 (DELFORTGROUP AG) 27 January 2022 (2022-01-27) See page 1, lines 5-25 and page 8, line 35 - page 9, line 4.
Y	
Y	JP 2019-532671 A (BOND STREET MFG LLC) 14 November 2019 (2019-11-14) See paragraph [0056].
A	KR 10-2020-0107584 A (KT & G CORPORATION) 16 September 2020 (2020-09-16) See entire document.
A	KR 10-2016-0098204 A (PHILIP MORRIS PRODUCTS S.A.) 18 August 2016 (2016-08-18) See entire document.
A	KR 10-2015-0116612 A (KT & G CORPORATION et al.) 16 October 2015 (2015-10-16) See entire document.
<input type="checkbox"/> Further documents are listed in the continuation of Box C. <input checked="" type="checkbox"/> See patent family annex.	
* Special categories of cited documents:	"T" later document published after the international filing date or priority date and not in conflict with the application but cited to understand the principle or theory underlying the invention "X" document of particular relevance; the claimed invention cannot be considered novel or cannot be considered to involve an inventive step when the document is taken alone "Y" document of particular relevance; the claimed invention cannot be considered to involve an inventive step when the document is combined with one or more other such documents, such combination being obvious to a person skilled in the art "&" document member of the same patent family
"A" document defining the general state of the art which is not considered to be of particular relevance	
"D" document cited by the applicant in the international application	
"E" earlier application or patent but published on or after the international filing date	
"L" document which may throw doubts on priority claim(s) or which is cited to establish the publication date of another citation or other special reason (as specified)	
"O" document referring to an oral disclosure, use, exhibition or other means	
"P" document published prior to the international filing date but later than the priority date claimed	
Date of the actual completion of the international search	Date of mailing of the international search report
18 May 2023	19 May 2023
Name and mailing address of the ISA/KR	Authorized officer
Korean Intellectual Property Office Government Complex-Daejeon Building 4, 189 Cheongsaro, Seo-gu, Daejeon 35208	
Facsimile No. +82-42-481-8578	Telephone No.

INTERNATIONAL SEARCH REPORT
Information on patent family members

International application No.
PCT/KR2023/001567

5
10
15
20
25
30
35
40
45
50
55

Patent document cited in search report			Publication date (day/month/year)	Patent family member(s)			Publication date (day/month/year)
WO	2022-018180	A1	27 January 2022	EP	4064884	A1	05 October 2022
				KR	10-2023-0043104	A	30 March 2023
JP	2019-532671	A	14 November 2019	EP	3518692	A1	07 August 2019
				US	2018-0084823	A1	29 March 2018
				WO	2018-064032	A1	05 April 2018
KR	10-2020-0107584	A	16 September 2020	KR	10-2218026	B1	18 February 2021
KR	10-2016-0098204	A	18 August 2016	CN	105792684	A	20 July 2016
				EP	3082483	A1	26 October 2016
				JP	2017-500021	A	05 January 2017
				JP	6626443	B2	25 December 2019
				US	10292421	B2	21 May 2019
				US	2016-0270437	A1	22 September 2016
				WO	2015-092071	A1	25 June 2015
KR	10-2015-0116612	A	16 October 2015	WO	2015-156608	A1	15 October 2015