



US00D744606S

(12) **United States Design Patent**
Eyring et al.

(10) **Patent No.:** **US D744,606 S**

(45) **Date of Patent:** **** Dec. 1, 2015**

- (54) **ANIMAL DETERRENT DEVICE**
- (71) Applicant: **Orbit Irrigation Products, Inc.**, North Salt Lake, UT (US)
- (72) Inventors: **Stuart Eyring**, Bountiful, UT (US); **Karl L. Connolly**, Bountiful, UT (US); **Landon T. Gwilliam**, Stanford, CA (US); **Andrew M. Urry**, Draper, UT (US)
- (73) Assignee: **Orbit Irrigation Products, Inc.**, North Salt Lake, UT (US)

D659,029 S 5/2012 Connolly et al.
 8,226,260 B2 7/2012 Whalan
 D674,865 S 1/2013 Eyring et al.

OTHER PUBLICATIONS

Contech Electronics, Inc. (The product shown in Attachment A hereto was sold or offered for sale on or before Feb. 14, 2011).
 Orbit Irrigation Products, Inc. (The products shown in Attachment B hereto were sold or offered for sale on or before Nov. 2008.).
 L.R. Nelson Corp. (The product(s) shown in Attachment C hereto were sold or offered for sale on or before Feb. 14, 2011).
 Orbit Irrigation Products, Inc. (The product(s) shown in Attachment D hereto were sold or offered for sale on or before Apr. 1, 2013.).

(**) Term: **14 Years**

* cited by examiner

(21) Appl. No.: **29/486,832**

Primary Examiner — Catheri Oliver-Garcia

(22) Filed: **Apr. 2, 2014**

(74) *Attorney, Agent, or Firm* — Austin Rapp & Hardman

(51) **LOC (10) Cl.** **22-06**

(52) **U.S. Cl.**

USPC **D22/120**

(58) **Field of Classification Search**

USPC D22/119–120; 43/2, 98, 112–114,
 43/120–121, 131–132.1, 139; D10/40, 46;
 119/712, 718, 720; 116/22 A

See application file for complete search history.

(57) **CLAIM**

The ornamental design for an animal deterrent device, as shown and described.

DESCRIPTION

FIG. 1 is an elevated perspective view of an embodiment of an animal deterrent device in an extended position, according to our new design;
 FIG. 2 is an enlarged view of the region within the line 2-2 of FIG. 1;
 FIG. 3 is a front view of the embodiment of the animal deterrent device shown in FIG. 1 in the extended position;
 FIG. 4 is an enlarged view of the region within the line 4-4 of FIG. 3;
 FIG. 5 is a first side view of the embodiment of the animal deterrent device shown in FIG. 1 in the extended position;
 FIG. 6 is an enlarged view of the region within the line 6-6 of FIG. 5;
 FIG. 7 is a rear view of the embodiment of the animal deterrent device shown in FIG. 1 in the extended position;
 FIG. 8 is an enlarged view of the region within the line 8-8 of FIG. 7;
 FIG. 9 is a second side view of the embodiment of the animal deterrent device shown in FIG. 1 in the extended position;

(56) **References Cited**

U.S. PATENT DOCUMENTS

4,366,562	A *	12/1982	McGinty	43/124
5,009,192	A	4/1991	Burman		
5,379,545	A *	1/1995	Gall et al.	43/131
5,458,093	A	10/1995	MacMillan		
D386,985	S *	12/1997	Cameron	D10/40
D415,240	S	10/1999	Jackson		
6,337,635	B1	1/2002	Ericksen et al.		
D460,800	S	7/2002	Jan		
D485,502	S *	1/2004	Clivio	D10/40
6,700,486	B1	3/2004	Banki		
7,198,009	B2	4/2007	Crist et al.		
D568,958	S	5/2008	Zovar et al.		
7,654,217	B2 *	2/2010	Sullivan	116/22 A
D639,894	S *	6/2011	Feuerstein	D22/120
D642,077	S	7/2011	Nies et al.		

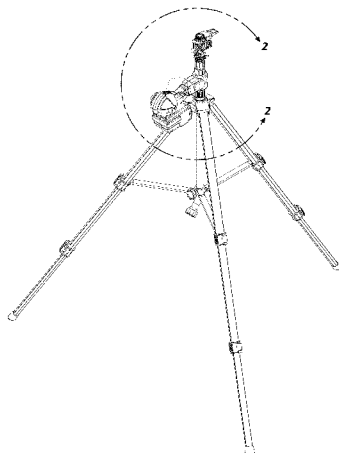

FIG. 10 is an enlarged view of the region within the line 10-10 of FIG. 9;

FIG. 11 is a top view of the embodiment of the animal deterrent device shown in FIG. 1 in the extended position;

FIG. 12 is an enlarged view of the region within the line 12-12 of FIG. 11;

FIG. 13 is a bottom view of the embodiment of the animal deterrent device shown in FIG. 1 in the extended position;

FIG. 14 is an enlarged view of the region within the line 14-14 of FIG. 13;

FIG. 15 is an elevated, perspective view of the embodiment of the animal deterrent device shown in FIG. 1 in a collapsed position;

FIG. 16 is a front view of the embodiment of the animal deterrent device shown in FIG. 1 in the collapsed position;

FIG. 17 is a first side view of the embodiment of the animal deterrent device shown in FIG. 1 in the collapsed position;

FIG. 18 is a rear view of the embodiment of the animal deterrent device shown in FIG. 1 in the collapsed position;

FIG. 19 is a second side view of the embodiment of the animal deterrent device shown in FIG. 1 in the collapsed position;

FIG. 20 is a top view of the embodiment of the animal deterrent device shown in FIG. 1 in the collapsed position;

FIG. 21 is a bottom view of the embodiment of the animal deterrent device shown in FIG. 1 in the collapsed position;

FIG. 22 is an elevated perspective view of another embodiment of an animal deterrent device in an extended position;

FIG. 23 is an enlarged view of the region within the line 23-23 of FIG. 22;

FIG. 24 is a front view of the embodiment of the animal deterrent device shown in FIG. 22 in the extended position;

FIG. 25 is an enlarged view of the region within the line 25-25 of FIG. 24;

FIG. 26 is a first side view of the embodiment of the animal deterrent device shown in FIG. 22 in the extended position;

FIG. 27 is an enlarged view of the region within the line 27-27 of FIG. 26;

FIG. 28 is a rear view of the embodiment of the animal deterrent device shown in FIG. 22 in the extended position;

FIG. 29 is an enlarged view of the region within the line 29-29 of FIG. 28;

FIG. 30 is a second side view of the embodiment of the animal deterrent device shown in FIG. 22 in the extended position;

FIG. 31 is an enlarged view of the region within the line 31-31 of FIG. 30;

FIG. 32 is a top view of the embodiment of the animal deterrent device shown in FIG. 22 in the extended position;

FIG. 33 is an enlarged view of the region within the line 33-33 of FIG. 32;

FIG. 34 is a bottom view of the embodiment of the animal deterrent device shown in FIG. 22 in the extended position;

FIG. 35 is an enlarged view of the region within the line 35-35 of FIG. 34;

FIG. 36 is an elevated perspective view of the embodiment of the animal deterrent device shown in FIG. 22 in a collapsed position;

FIG. 37 is a front view of the embodiment of the animal deterrent device shown in FIG. 22 in the collapsed position;

FIG. 38 is a first side view of the embodiment of the animal deterrent device shown in FIG. 22 in the collapsed position;

FIG. 39 is a rear view of the embodiment of the animal deterrent device shown in FIG. 22 in the collapsed position;

FIG. 40 is a second side view of the embodiment of the animal deterrent device shown in FIG. 22 in the collapsed position;

FIG. 41 is a top view of the embodiment of the animal deterrent device shown in FIG. 22 in the collapsed position; and,

FIG. 42 is a bottom view of the embodiment of the animal deterrent device shown in FIG. 22 in the collapsed position.

Portions shown in broken lines comprise no part of the claimed design. In addition, any portion surrounded by broken lines also comprises no part of the claimed design.

1 Claim, 42 Drawing Sheets

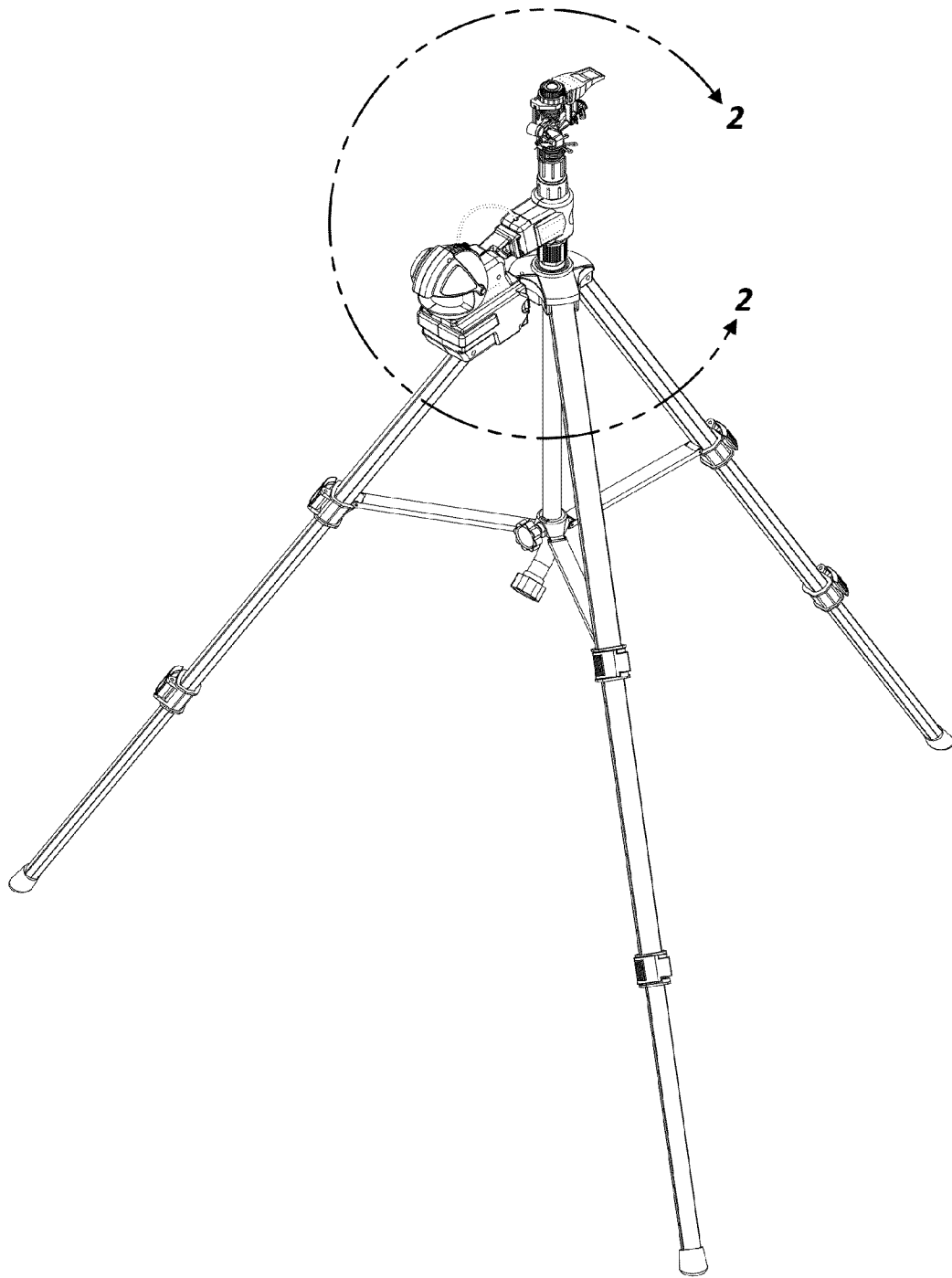

FIG. 1

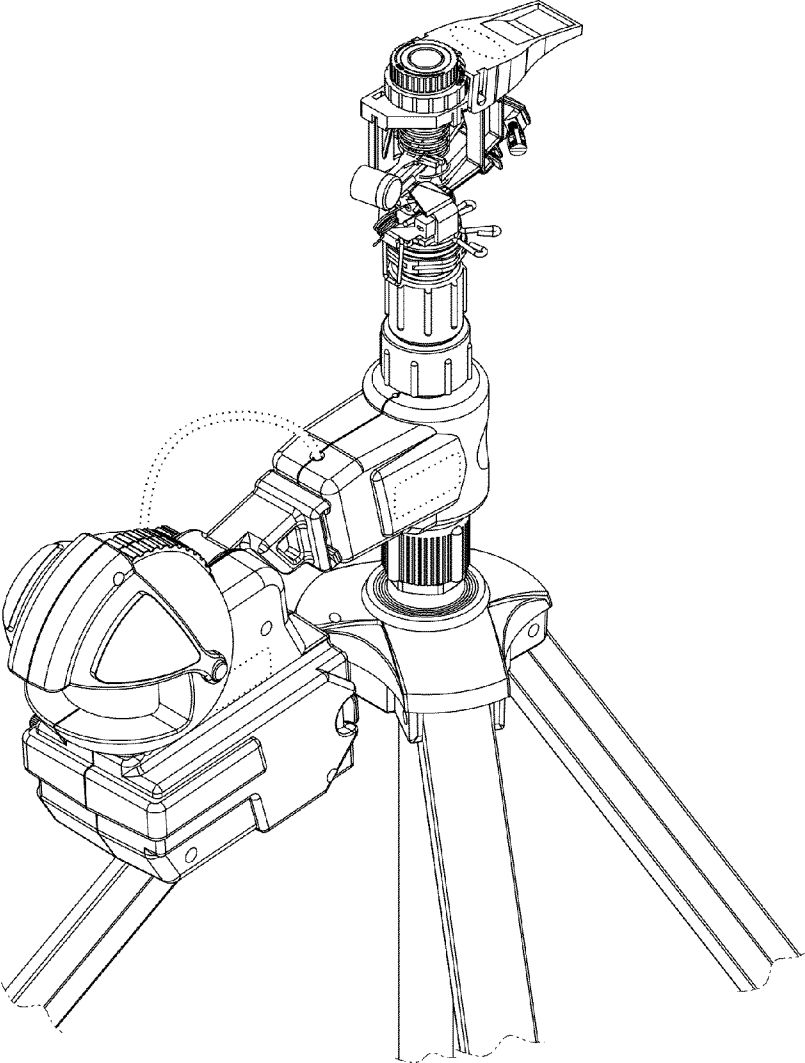

FIG. 2

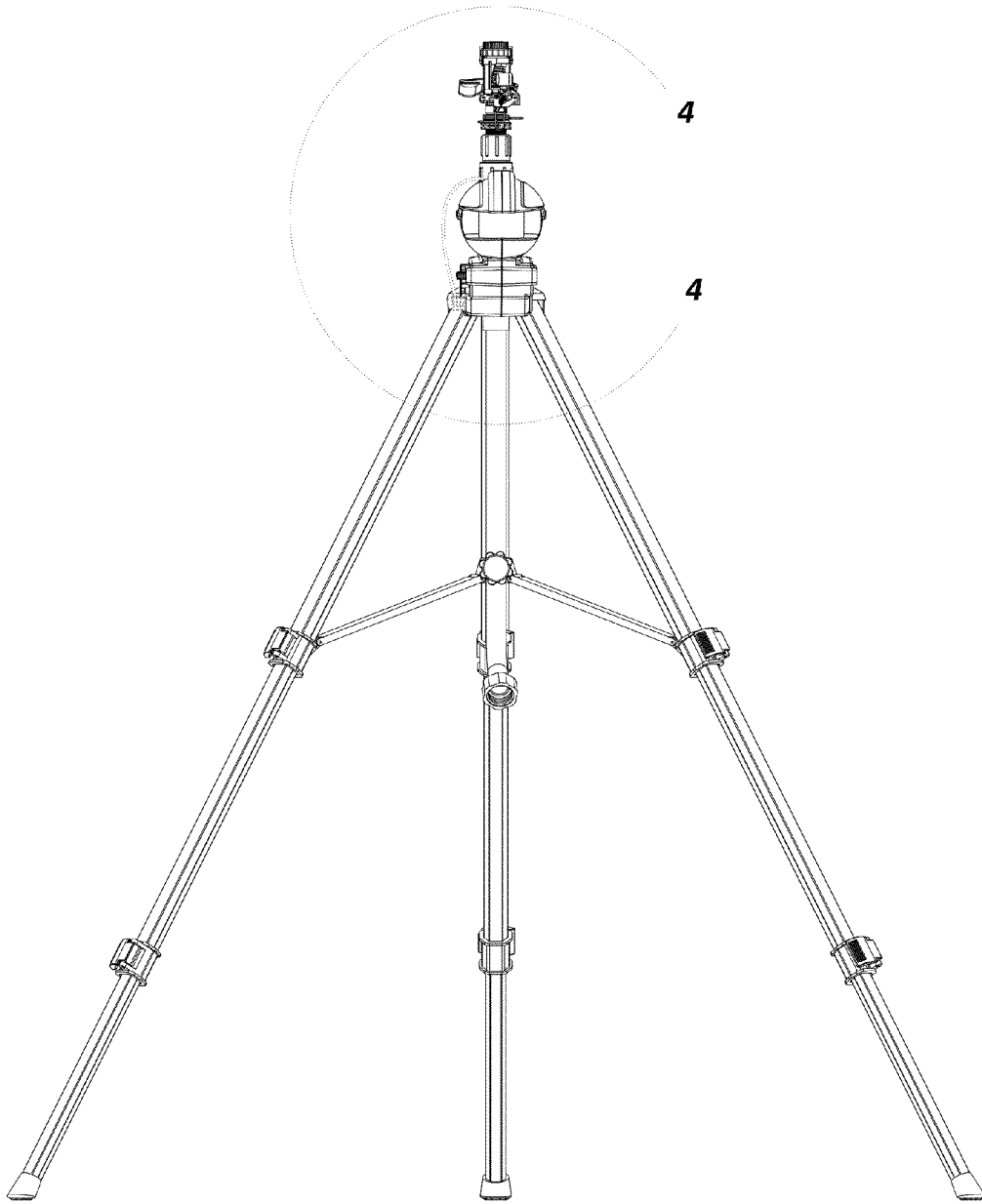

FIG. 3

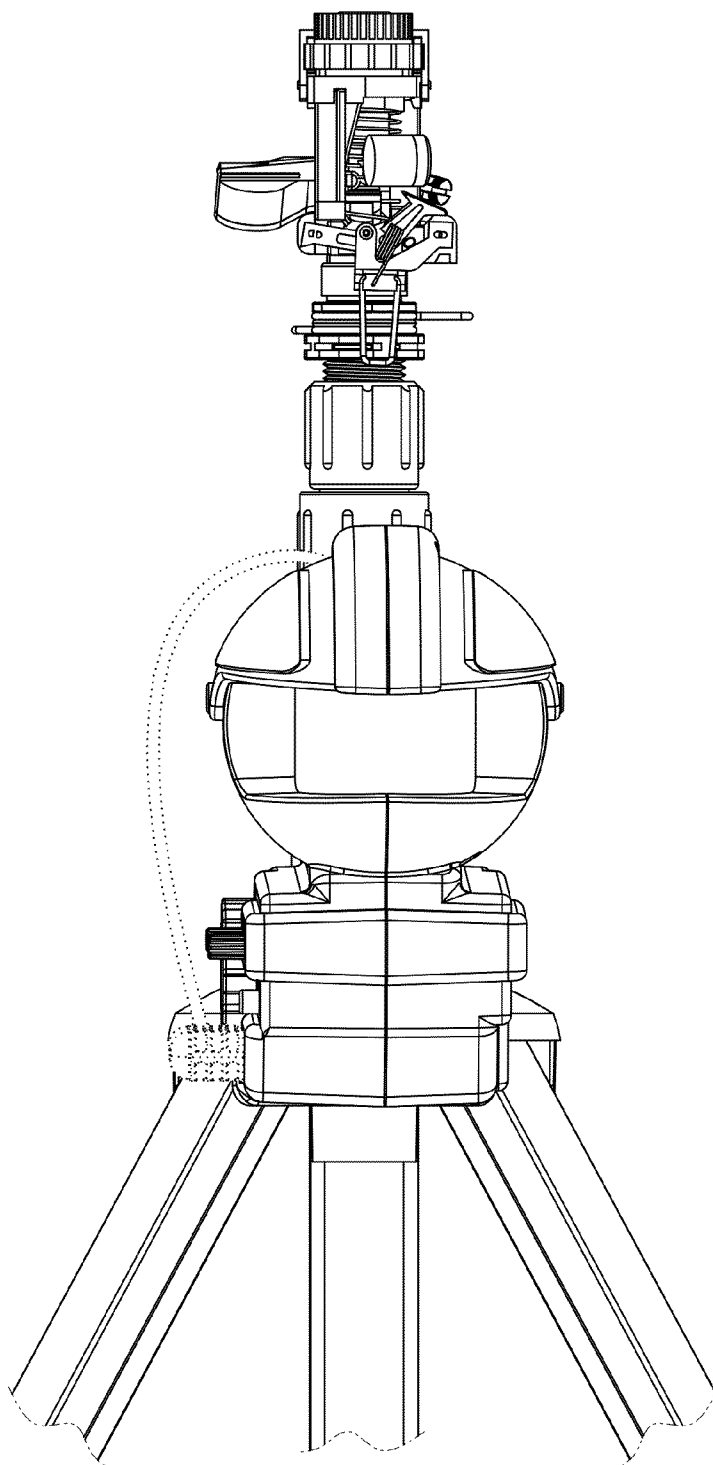

FIG. 4

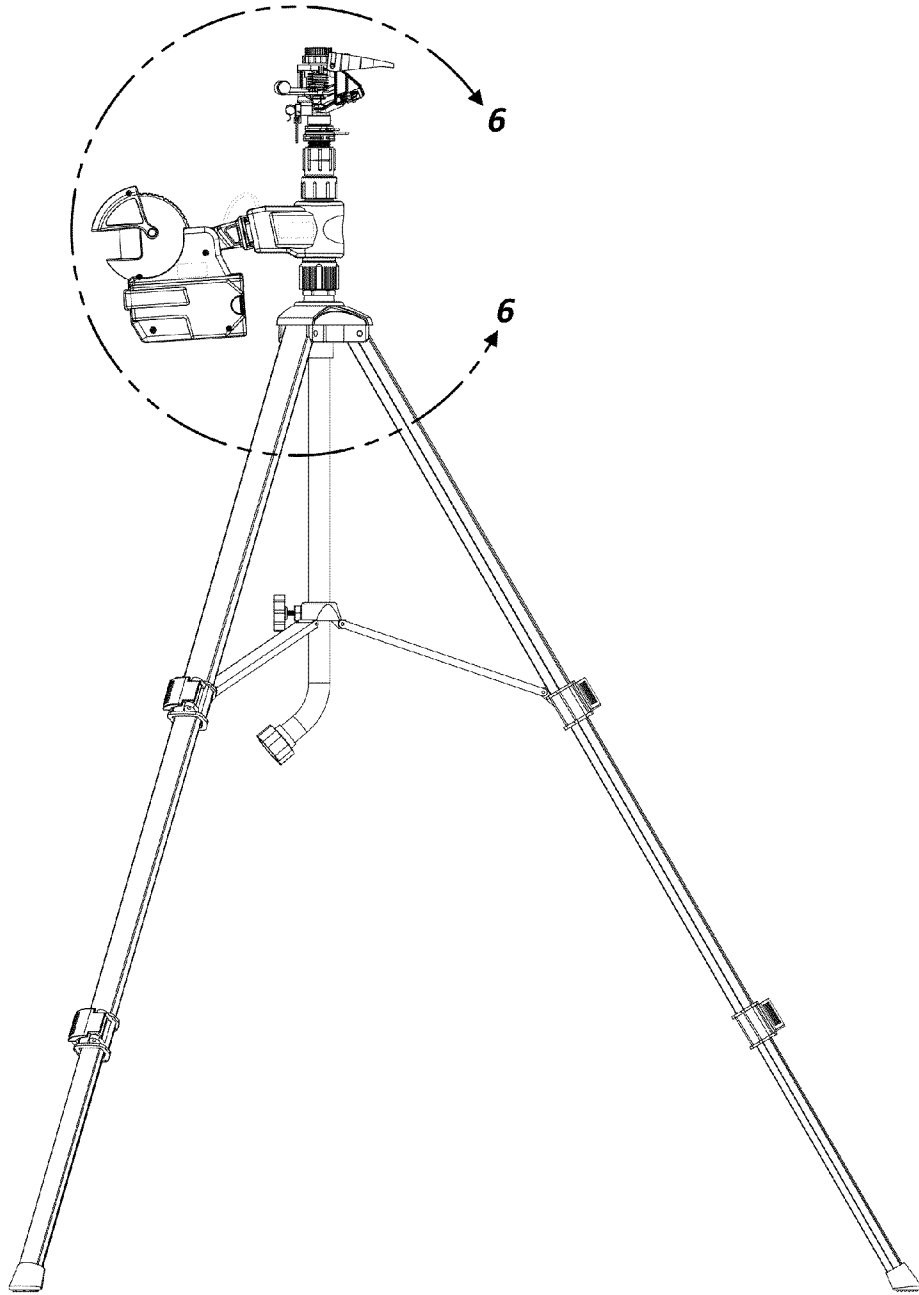

FIG. 5

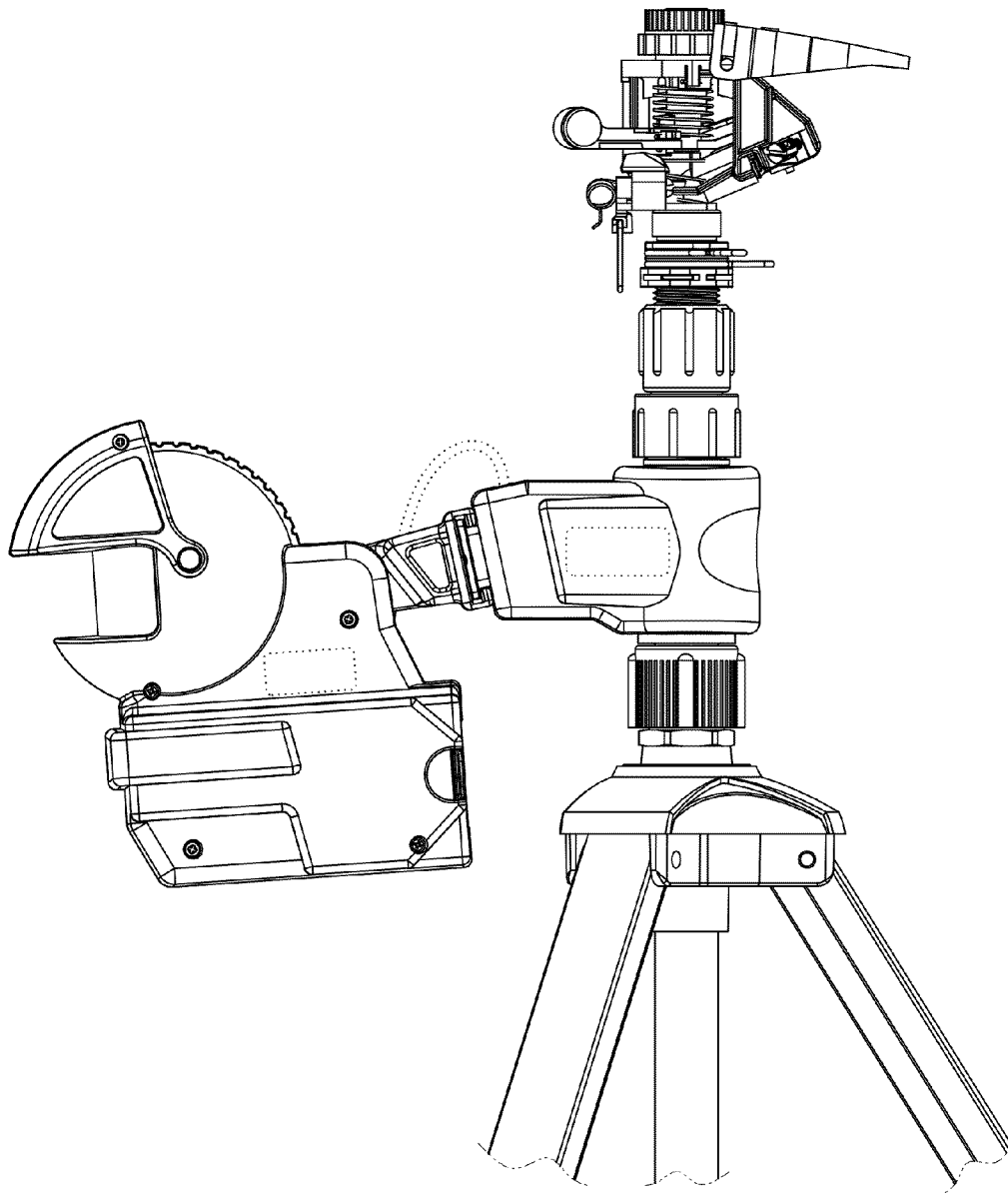

FIG. 6

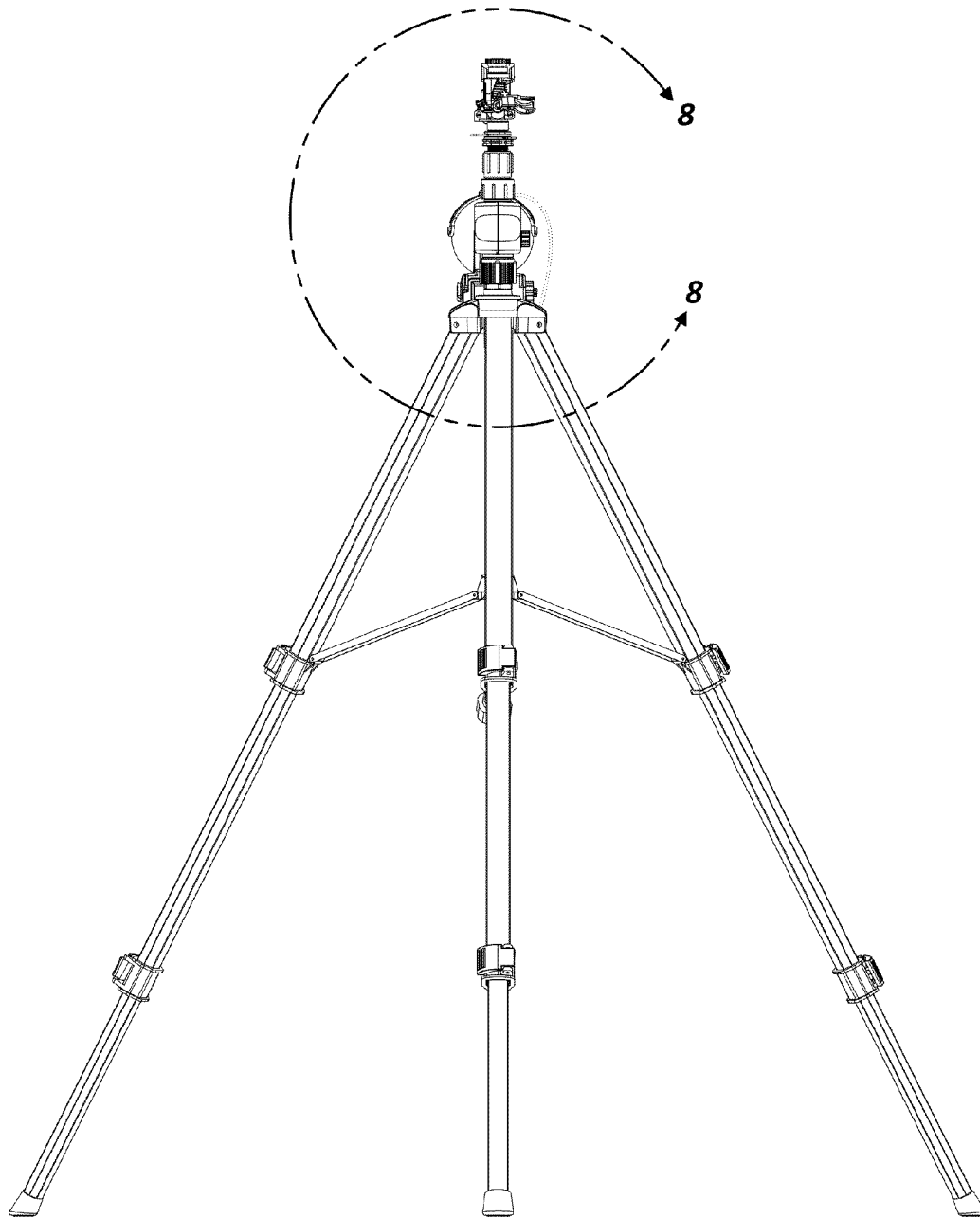

FIG. 7

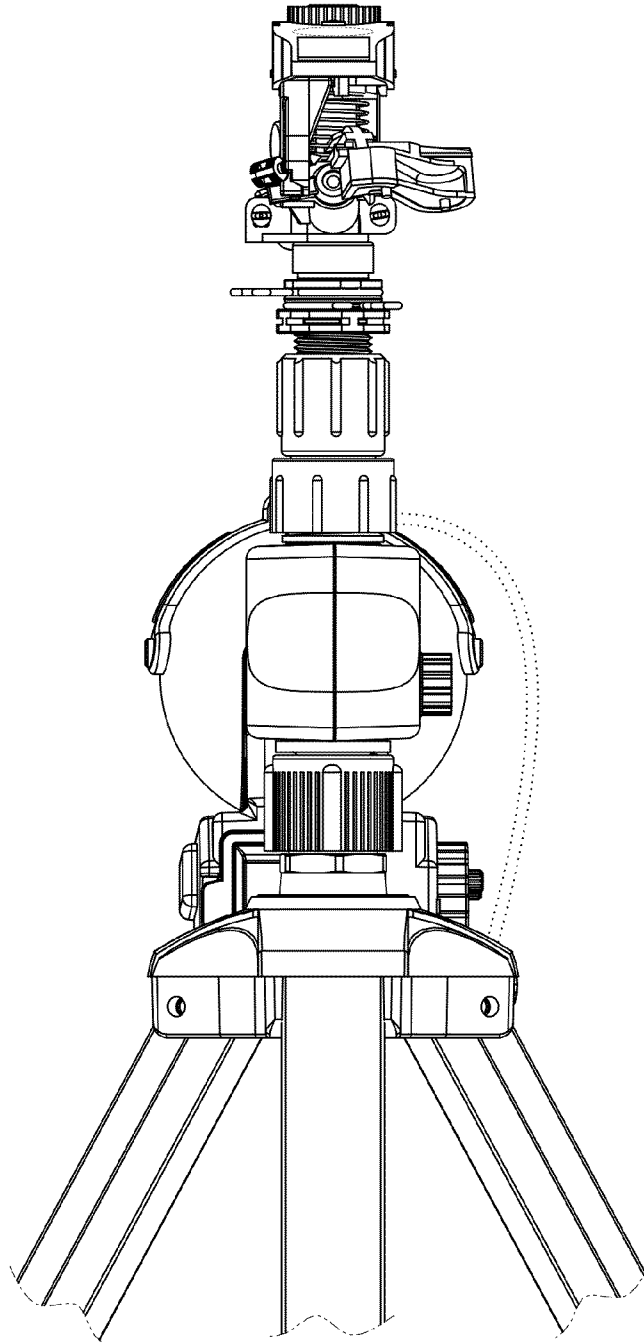

FIG. 8

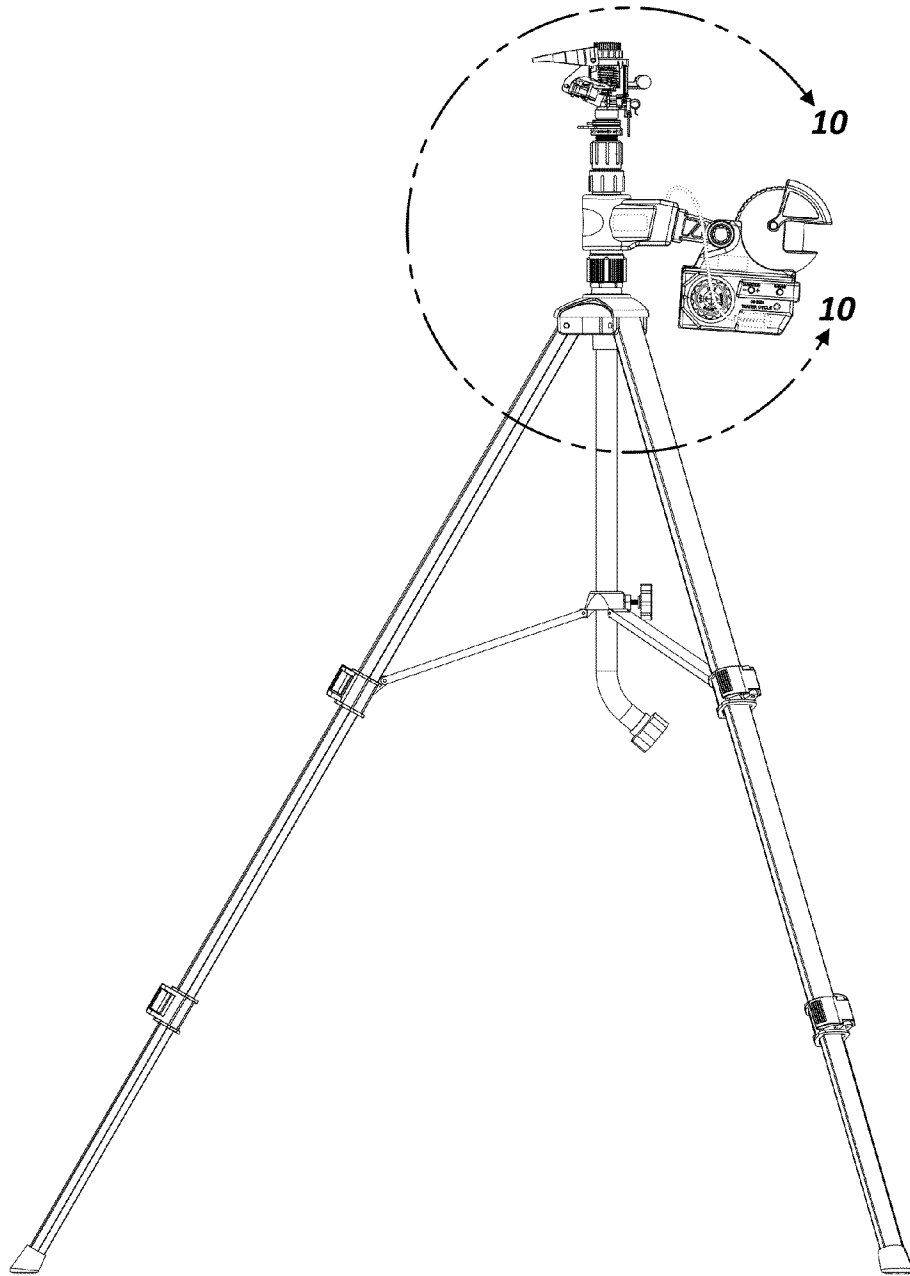

FIG. 9

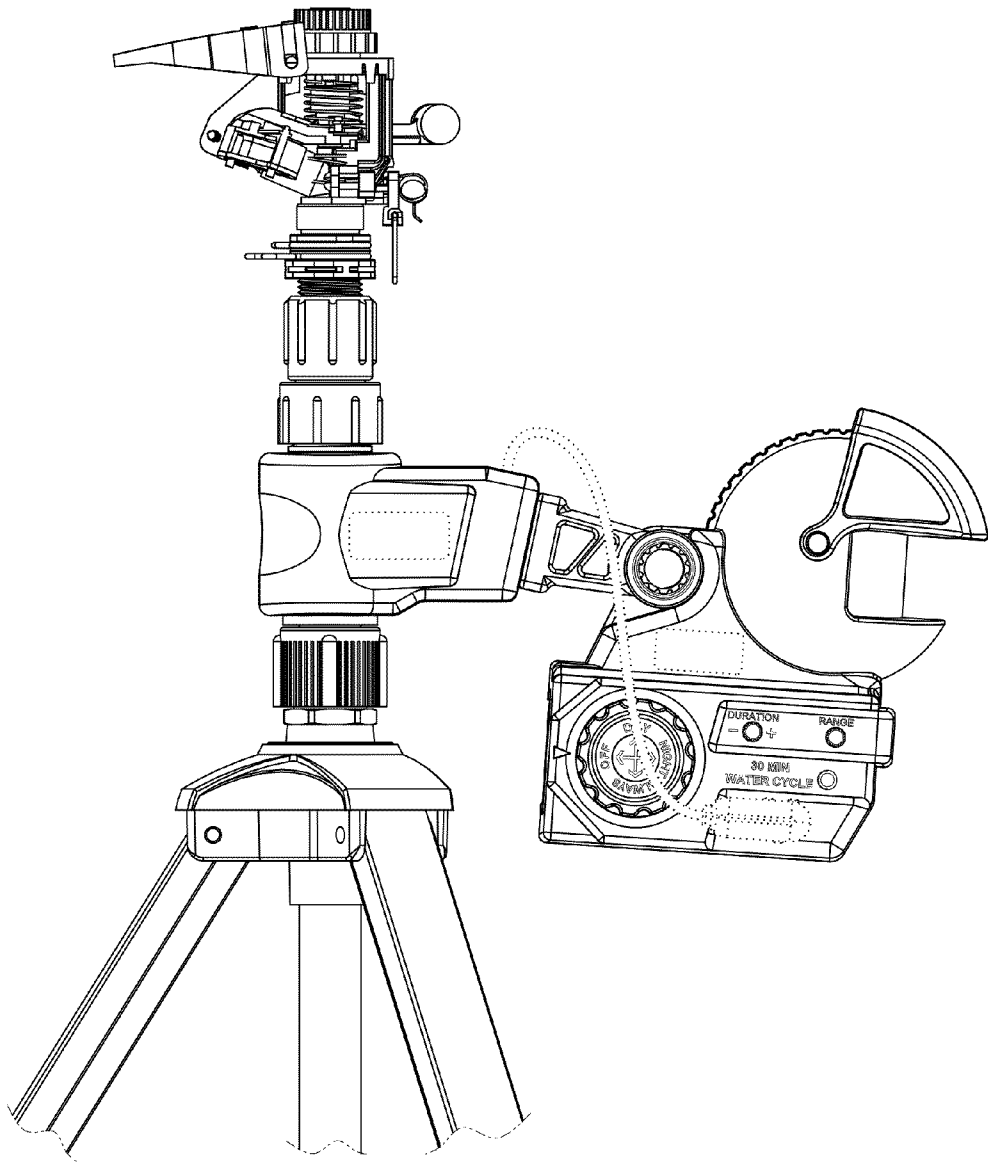

FIG. 10

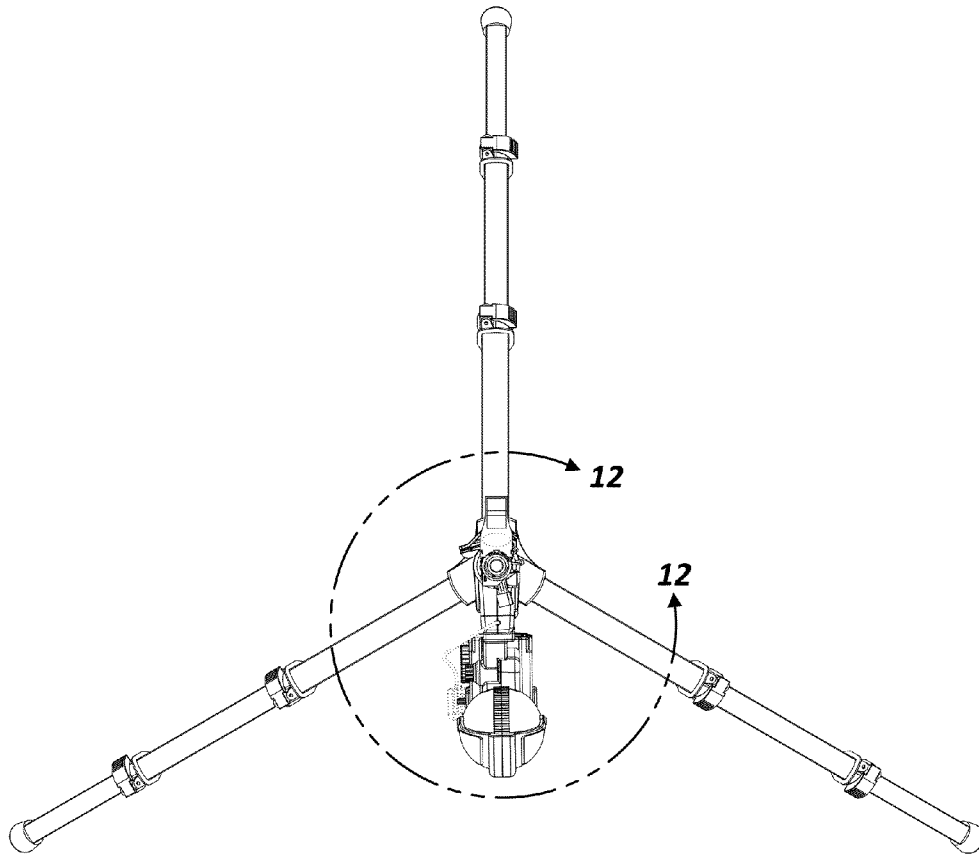

FIG. 11

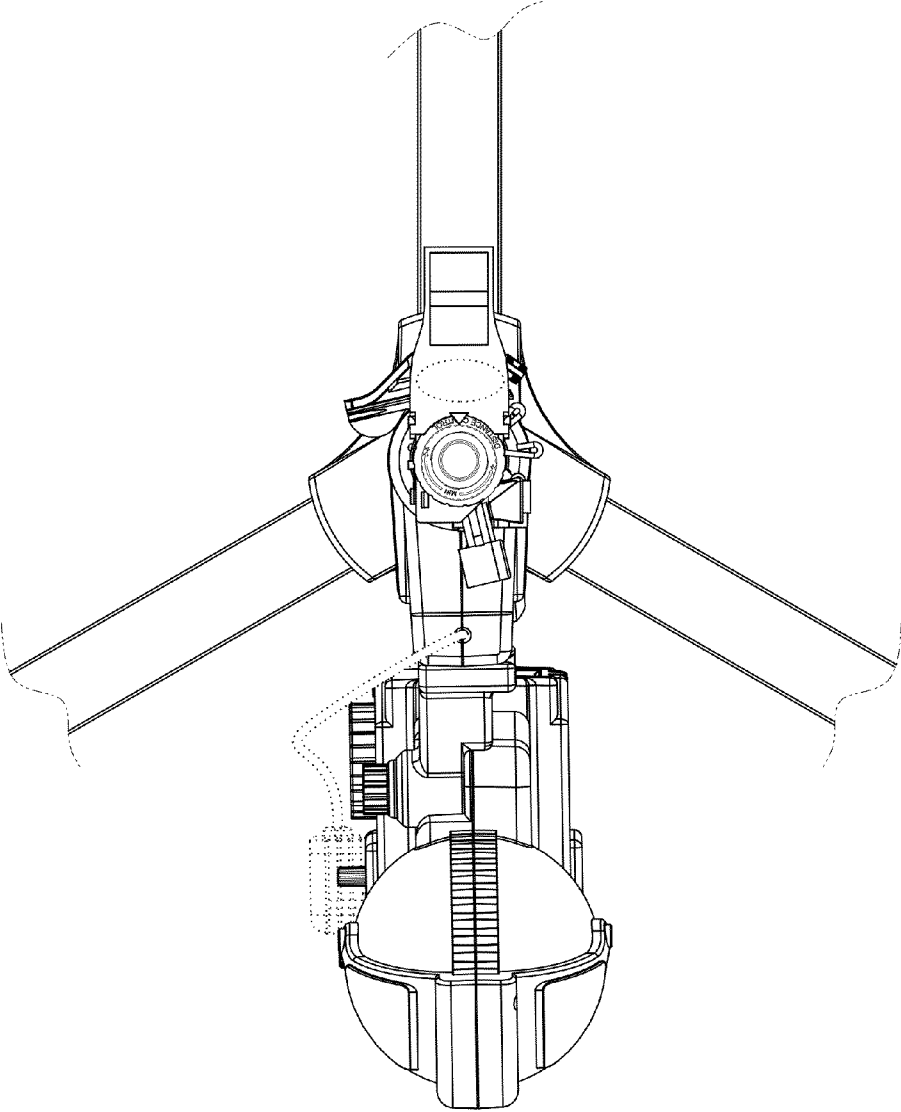

FIG. 12

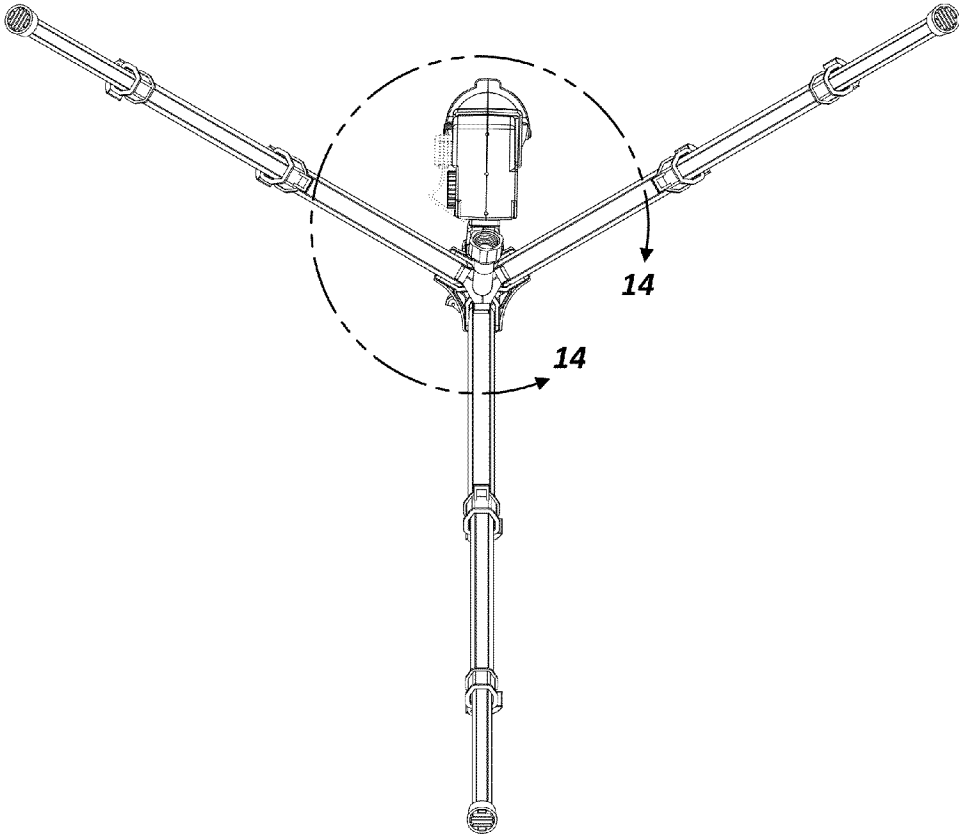

FIG. 13

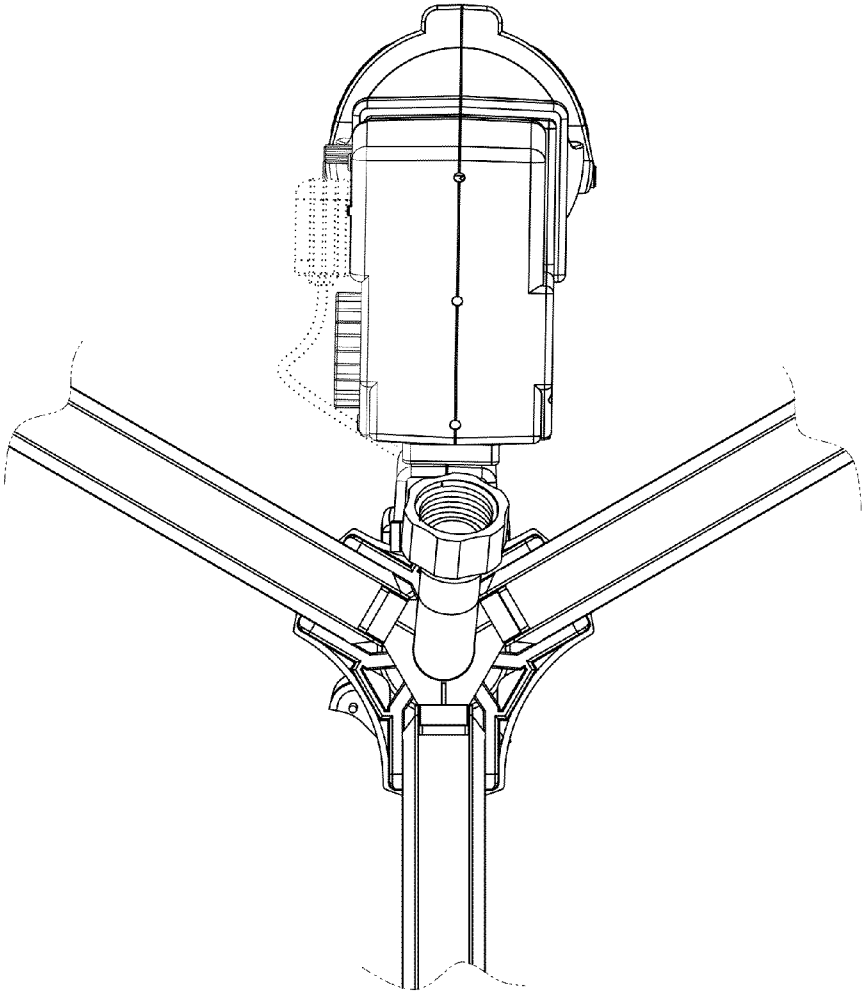

FIG. 14

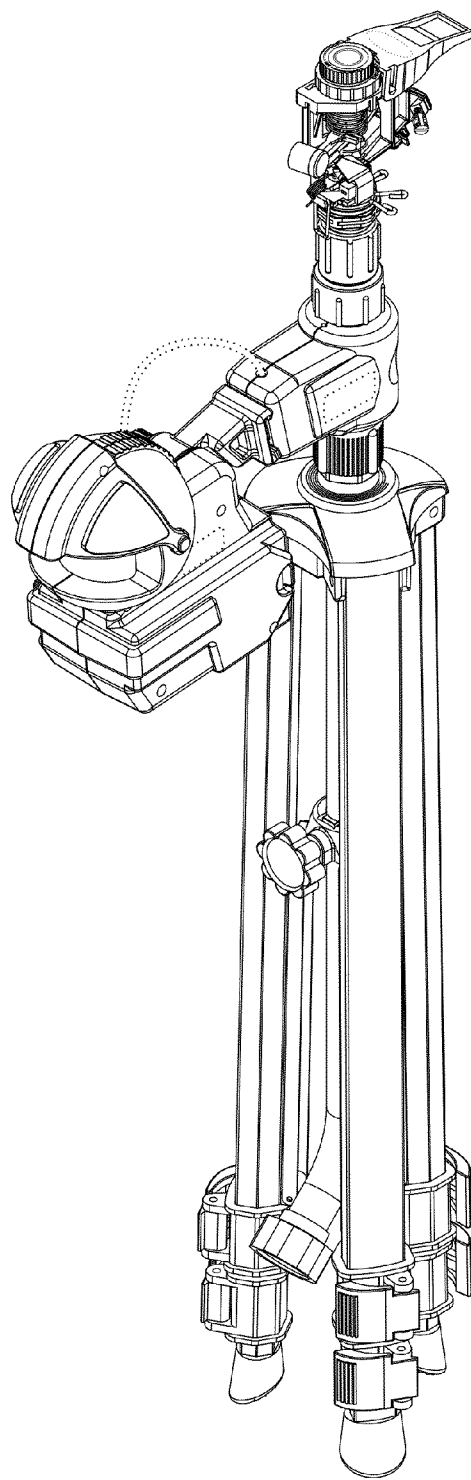

FIG. 15

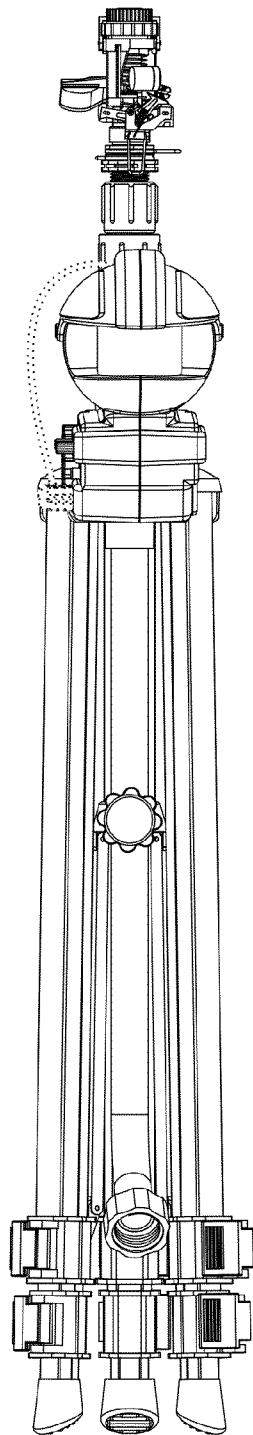

FIG. 16

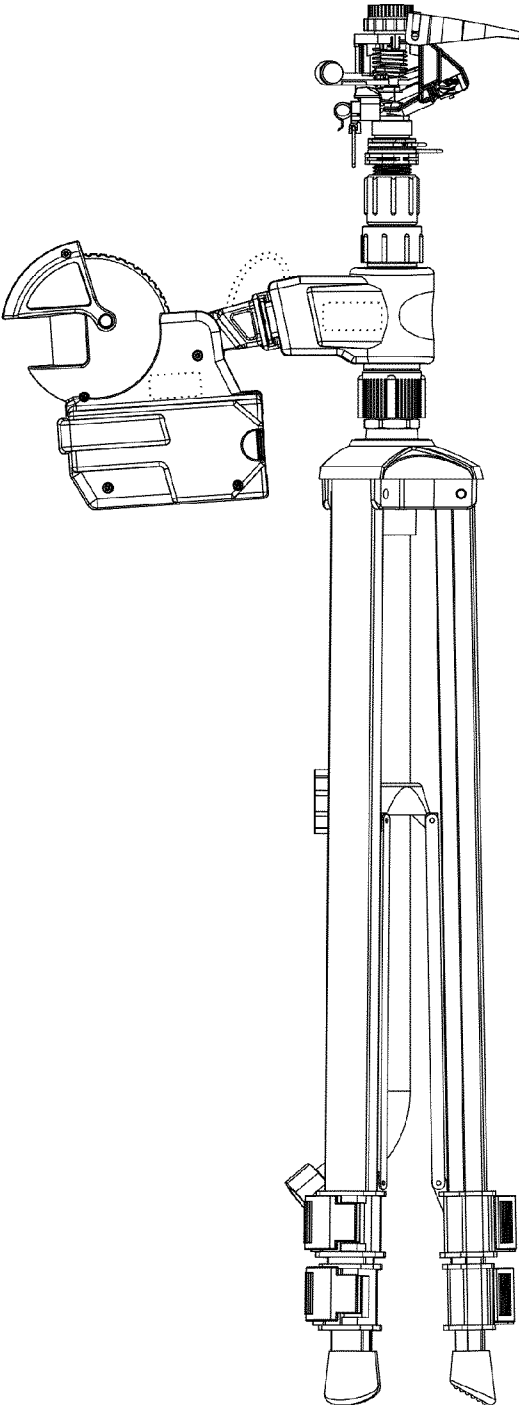

FIG. 17

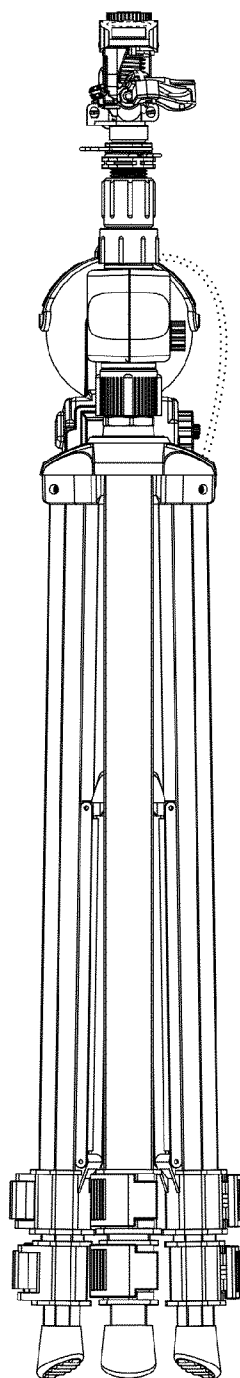

FIG. 18

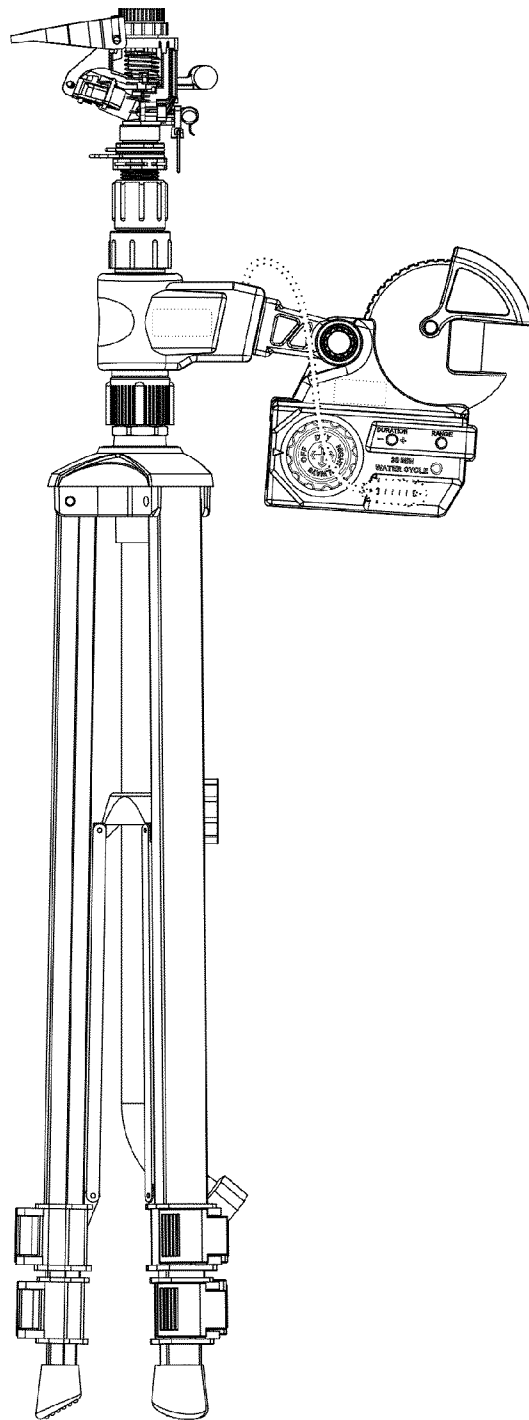

FIG. 19

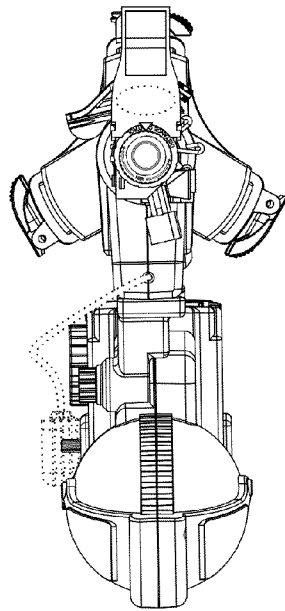

FIG. 20

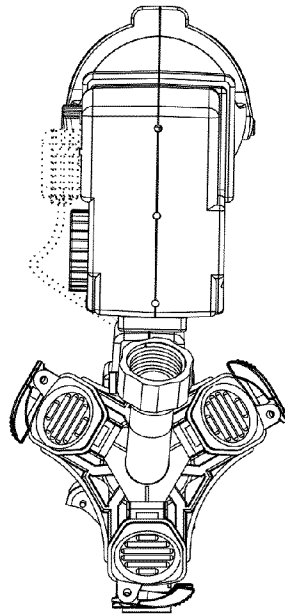

FIG. 21

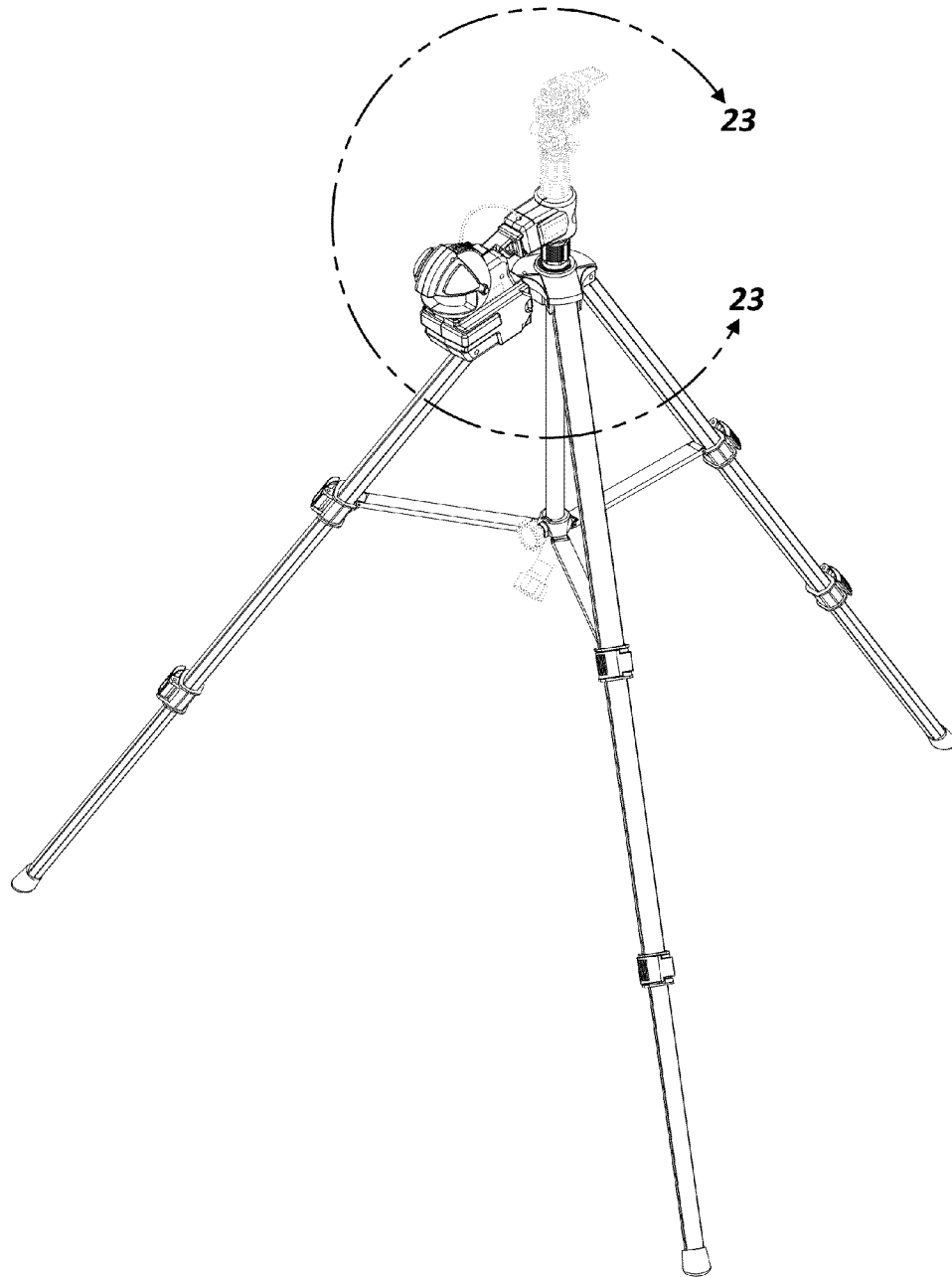

FIG. 22

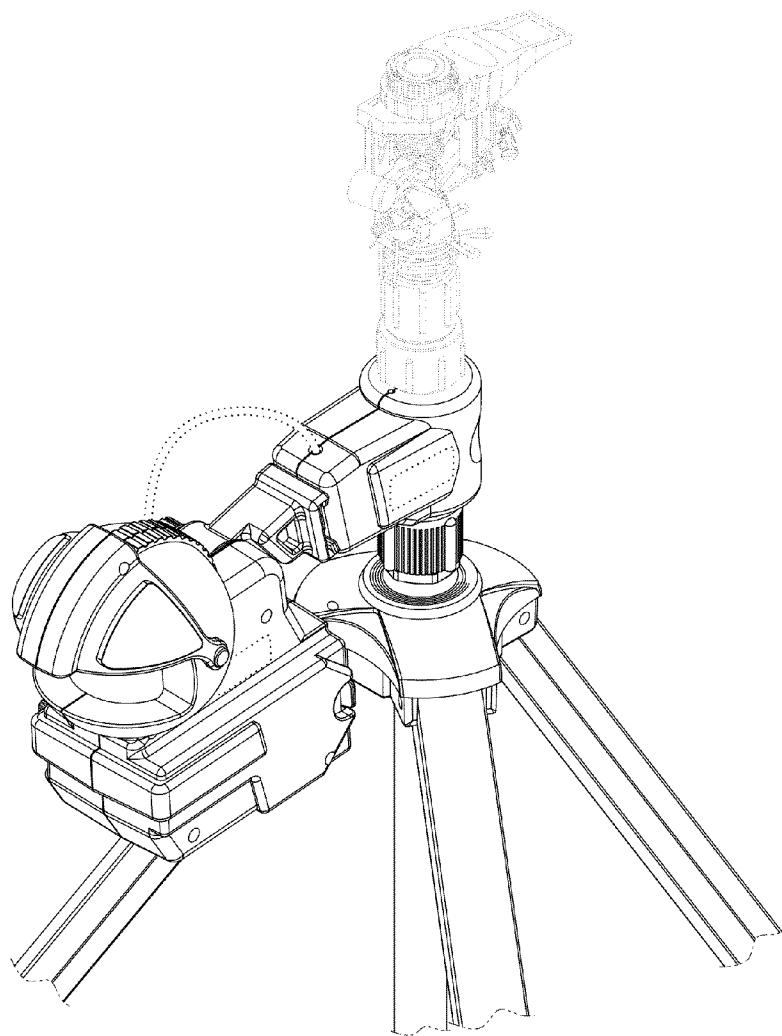

FIG. 23

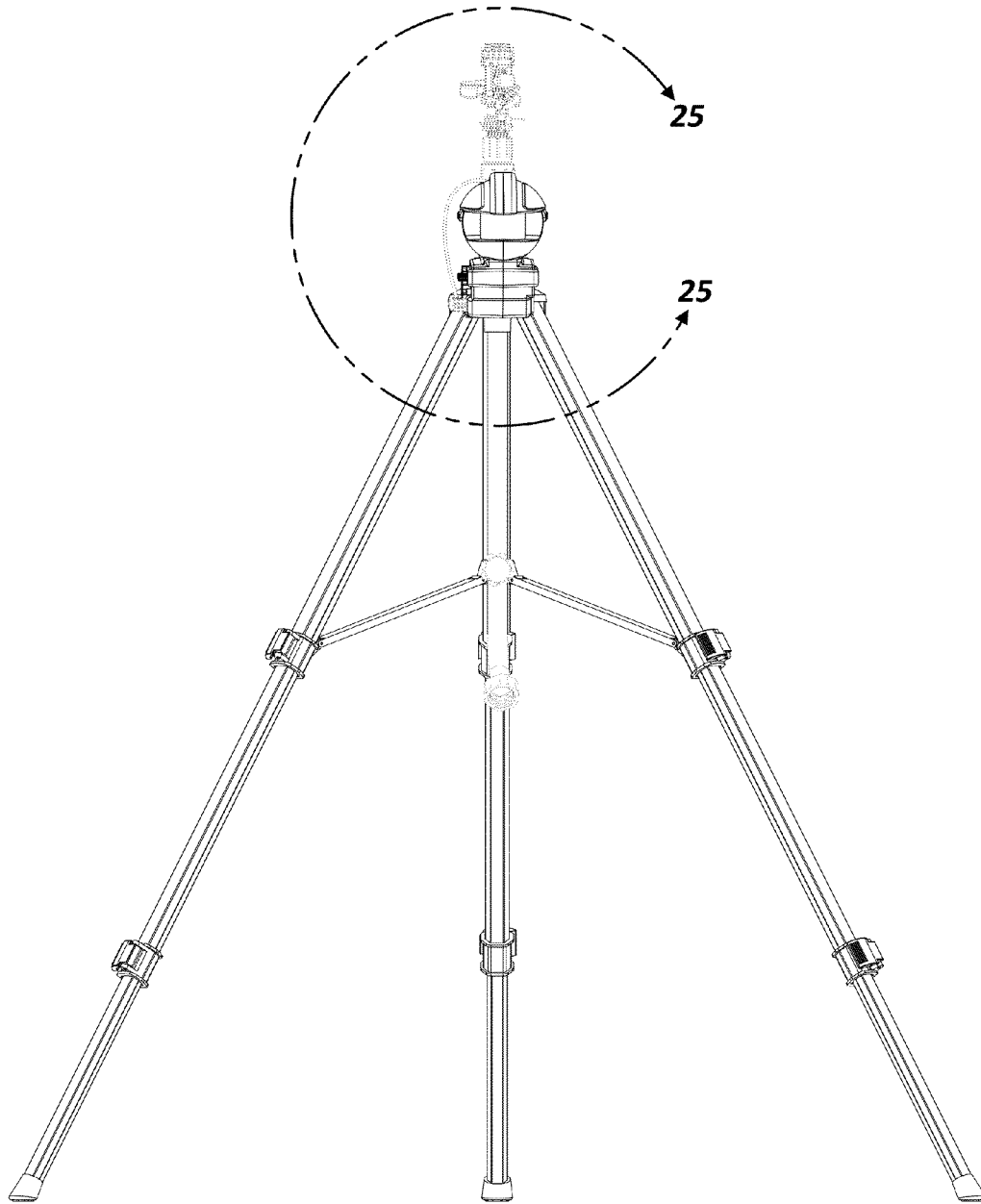

FIG. 24

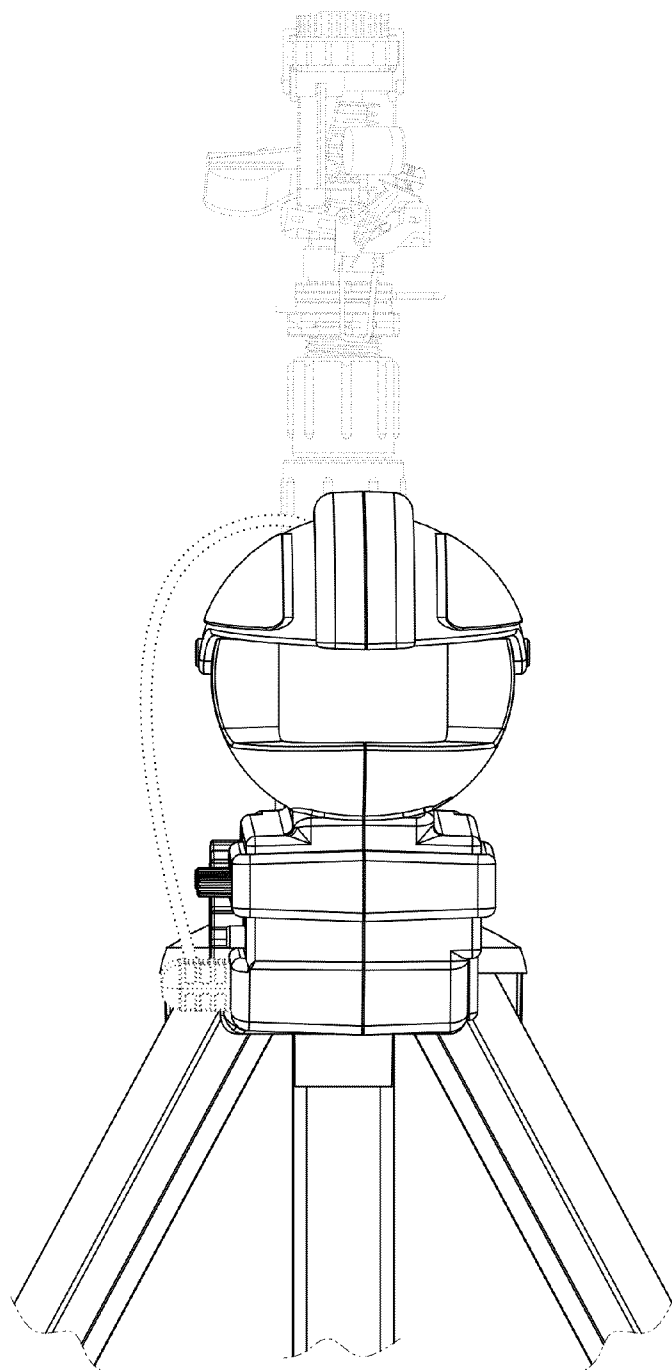

FIG. 25

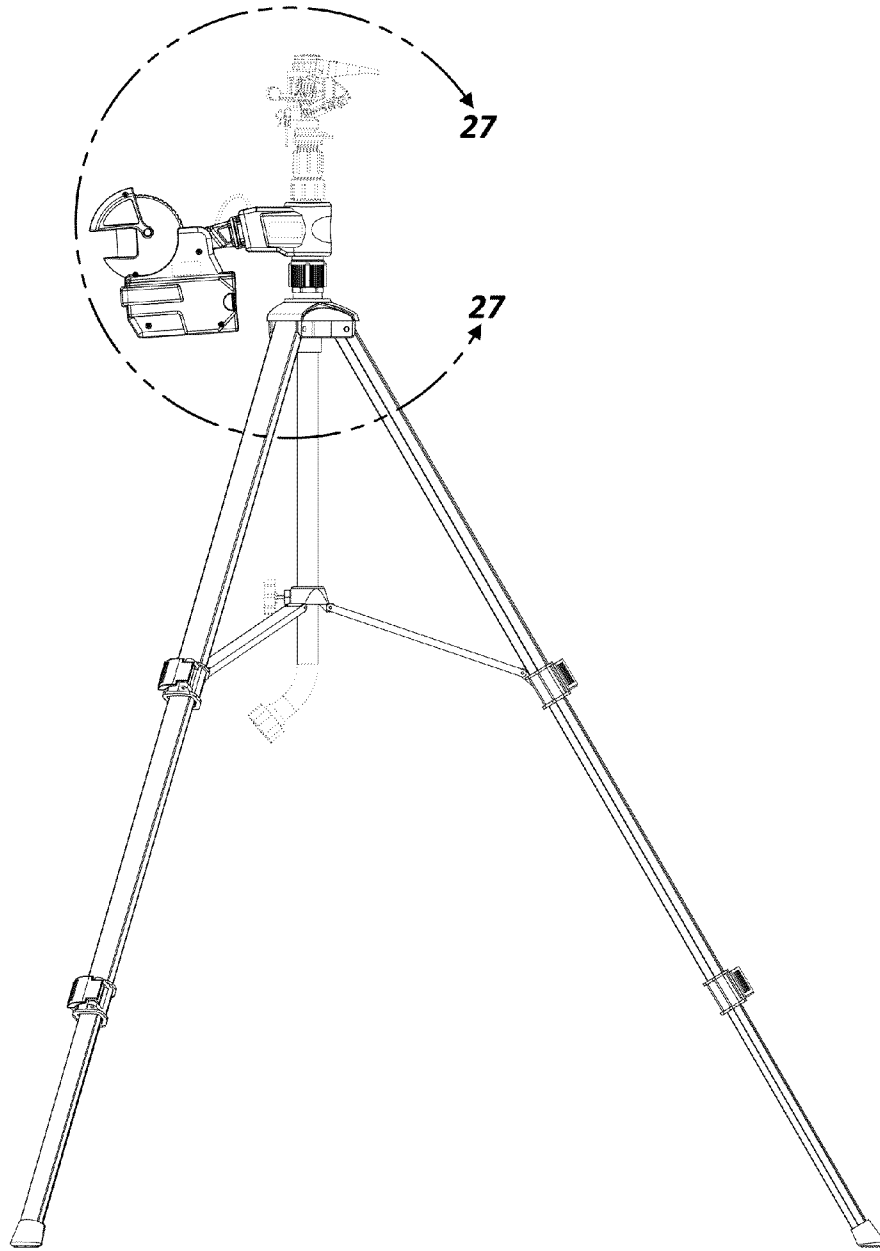

FIG. 26

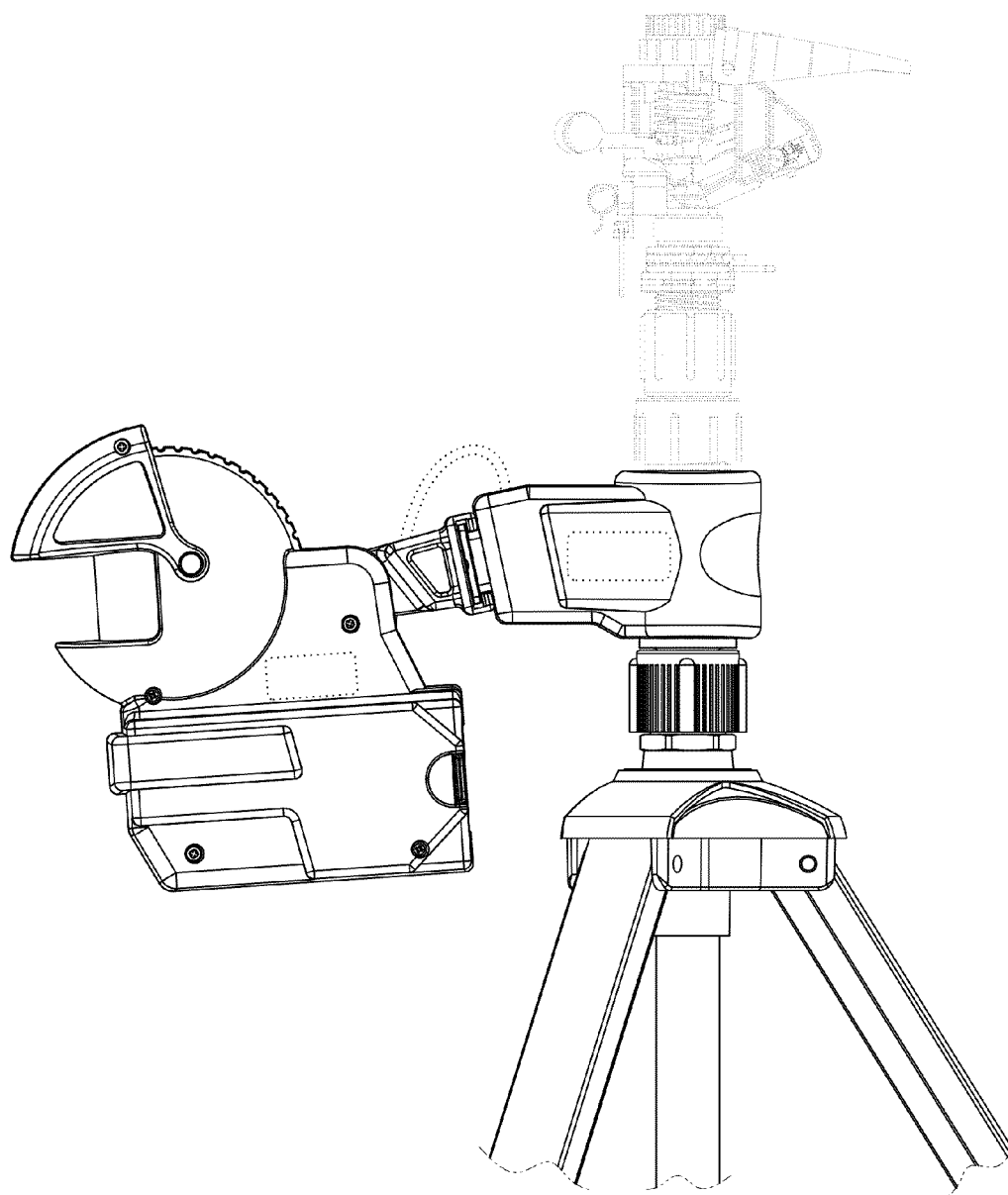

FIG. 27

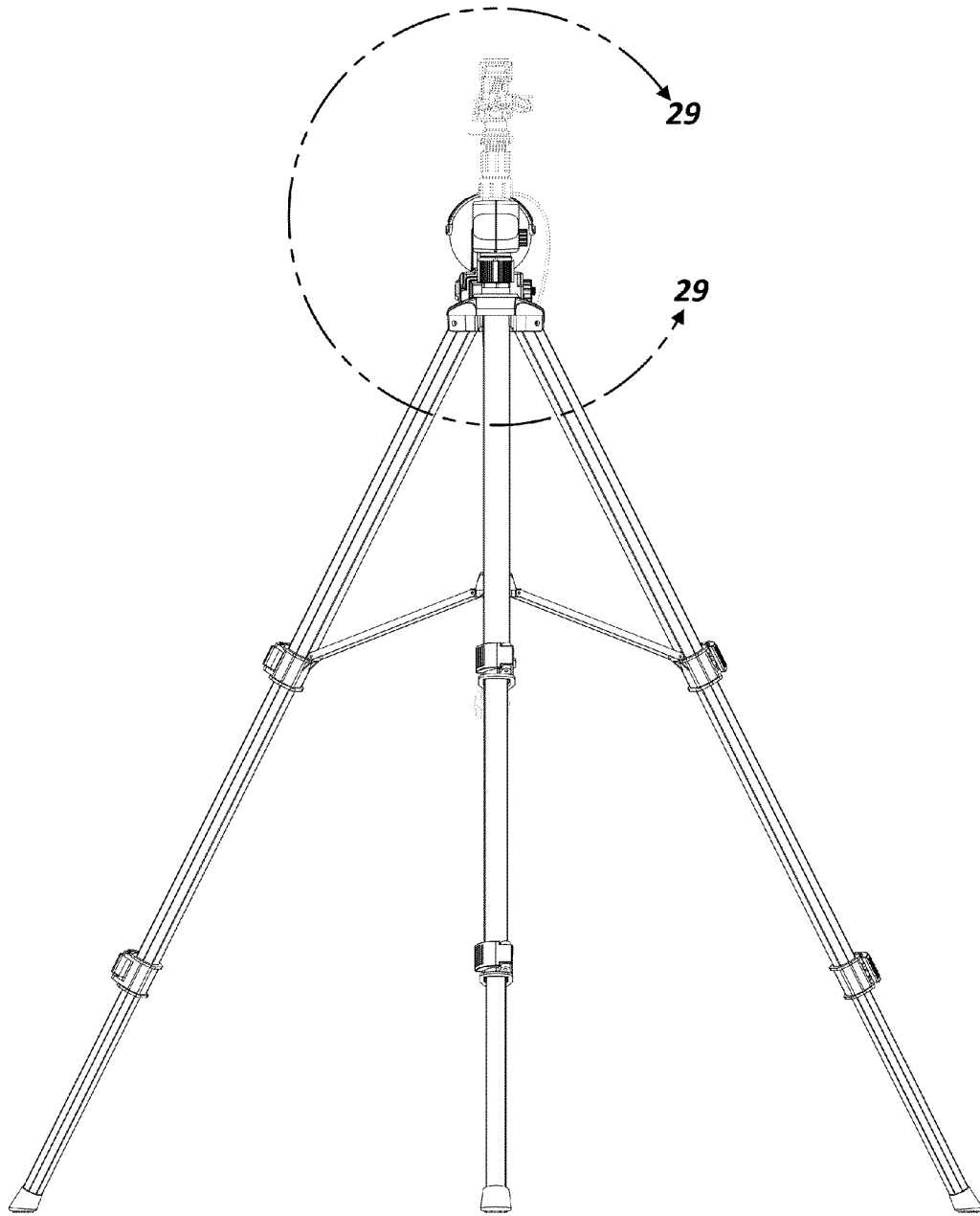

FIG. 28

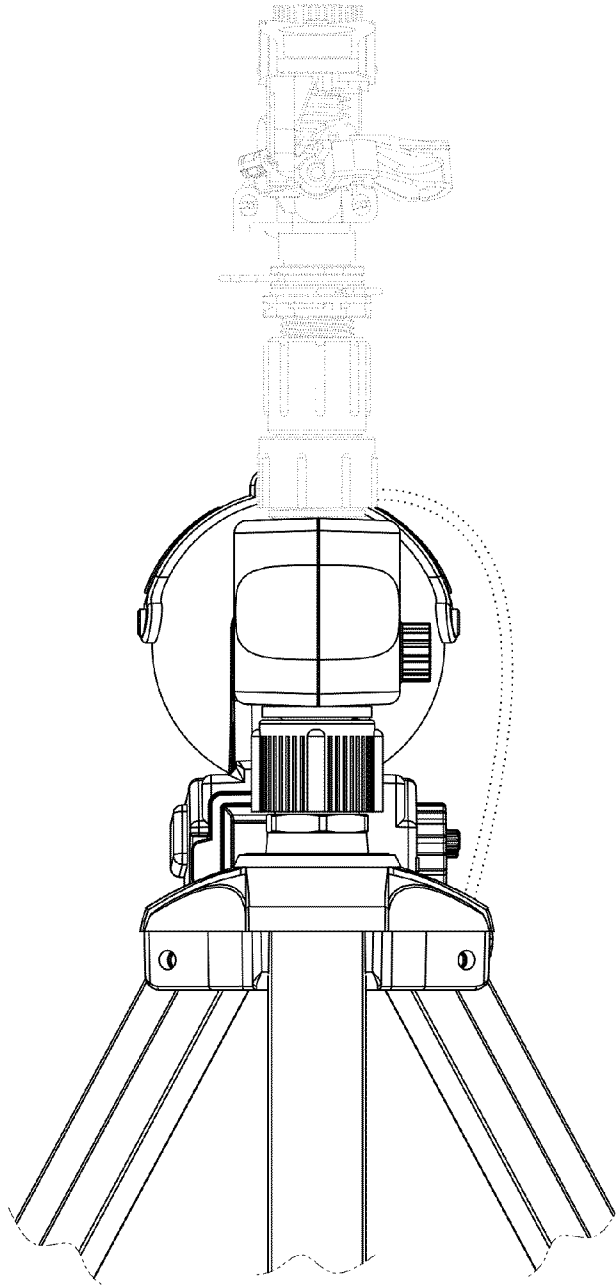

FIG. 29

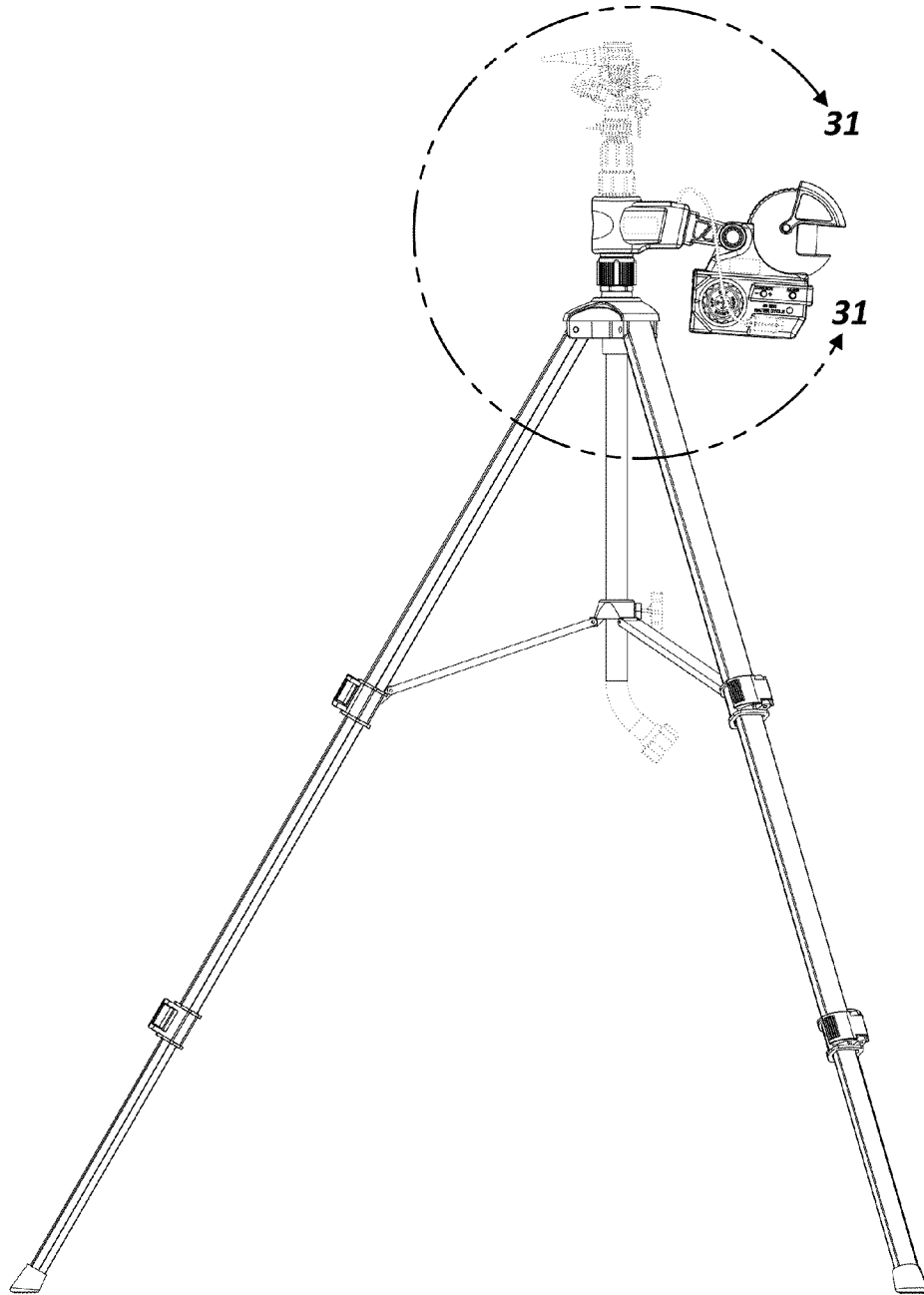

FIG. 30

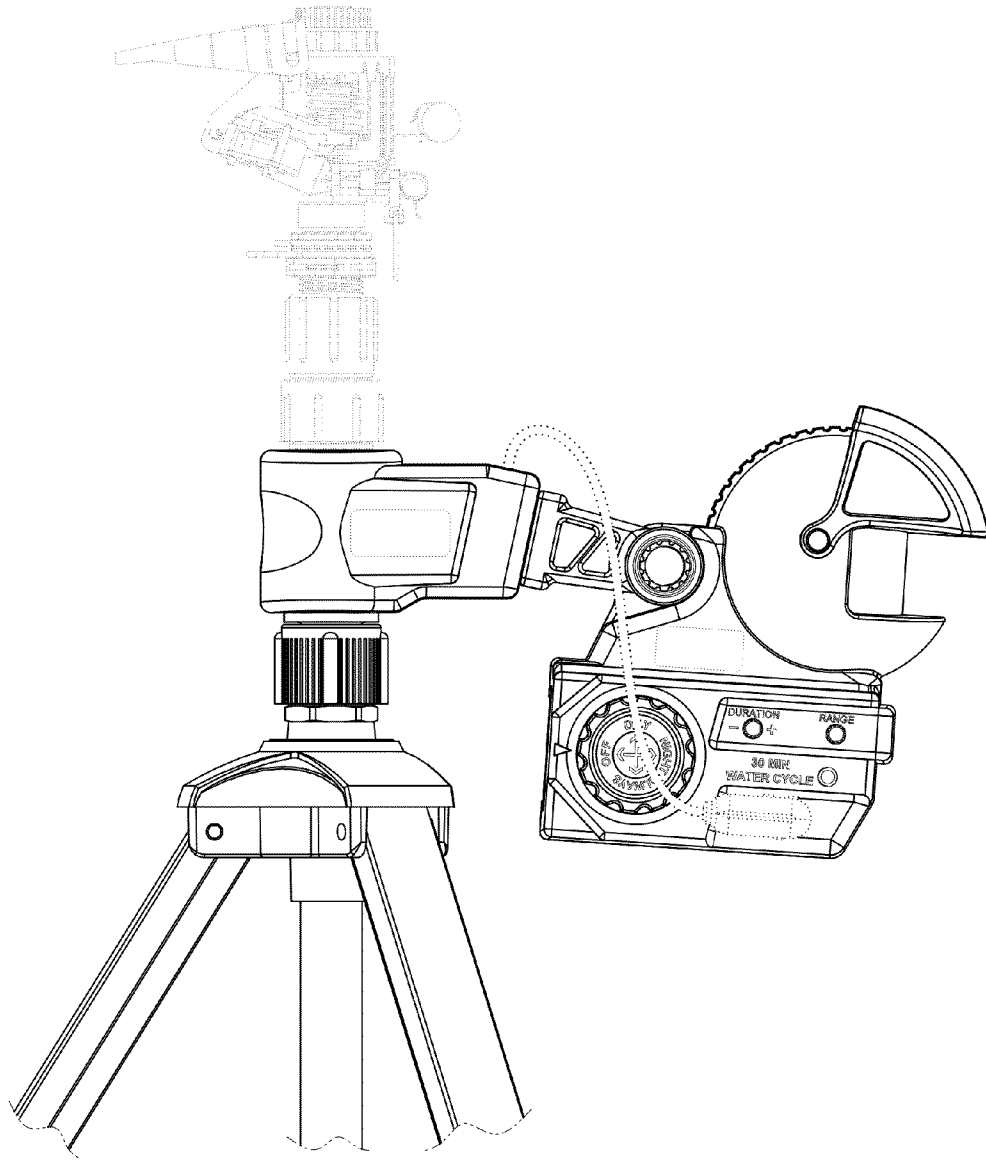

FIG. 31

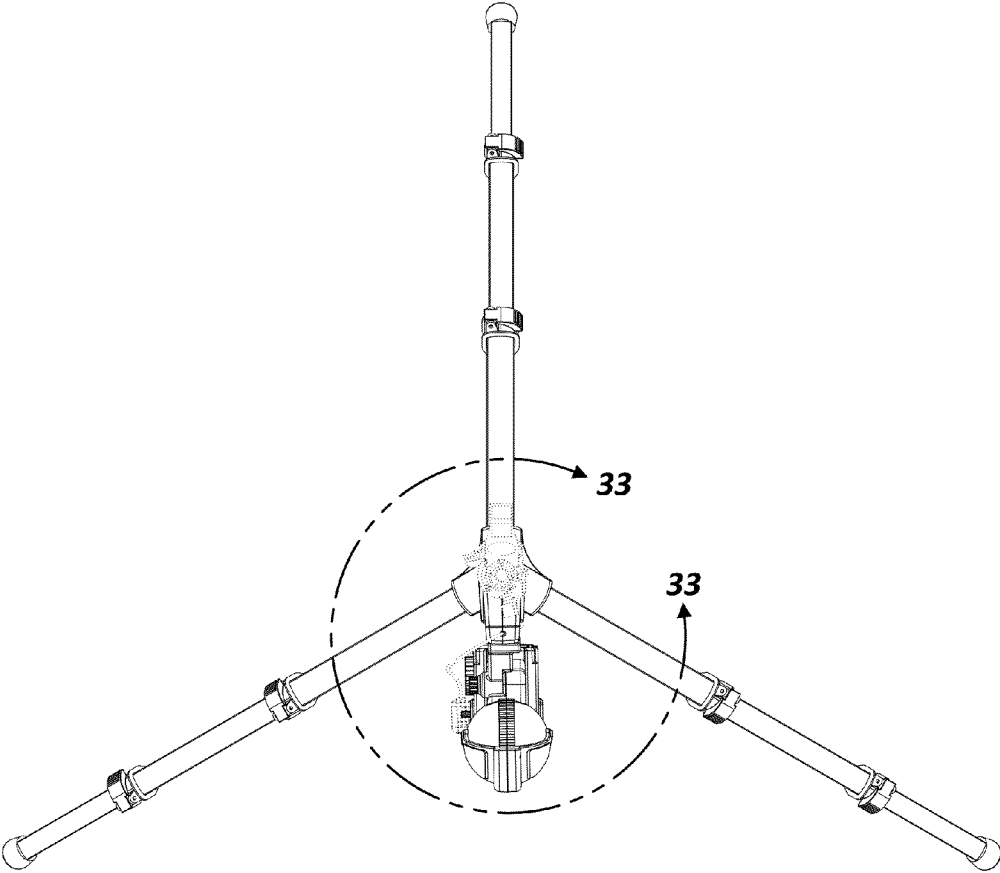

FIG. 32

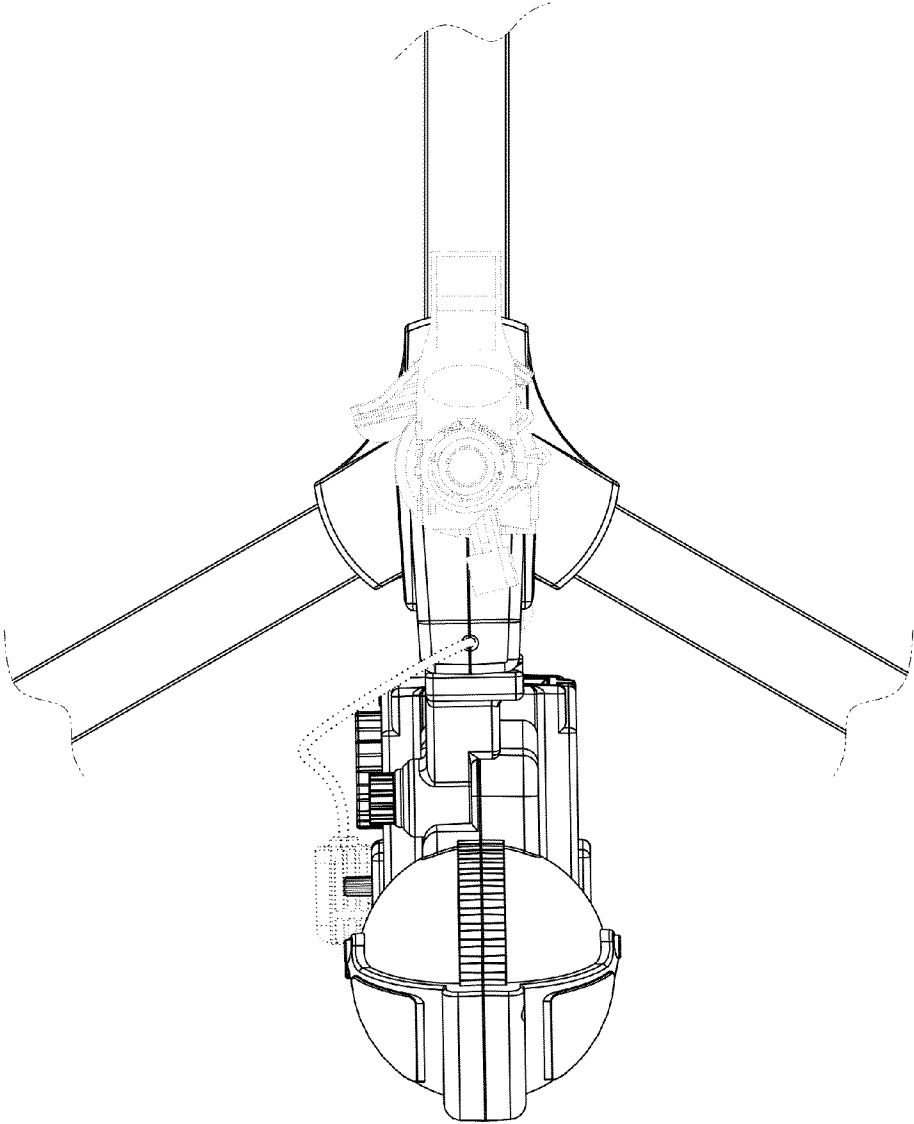

FIG. 33

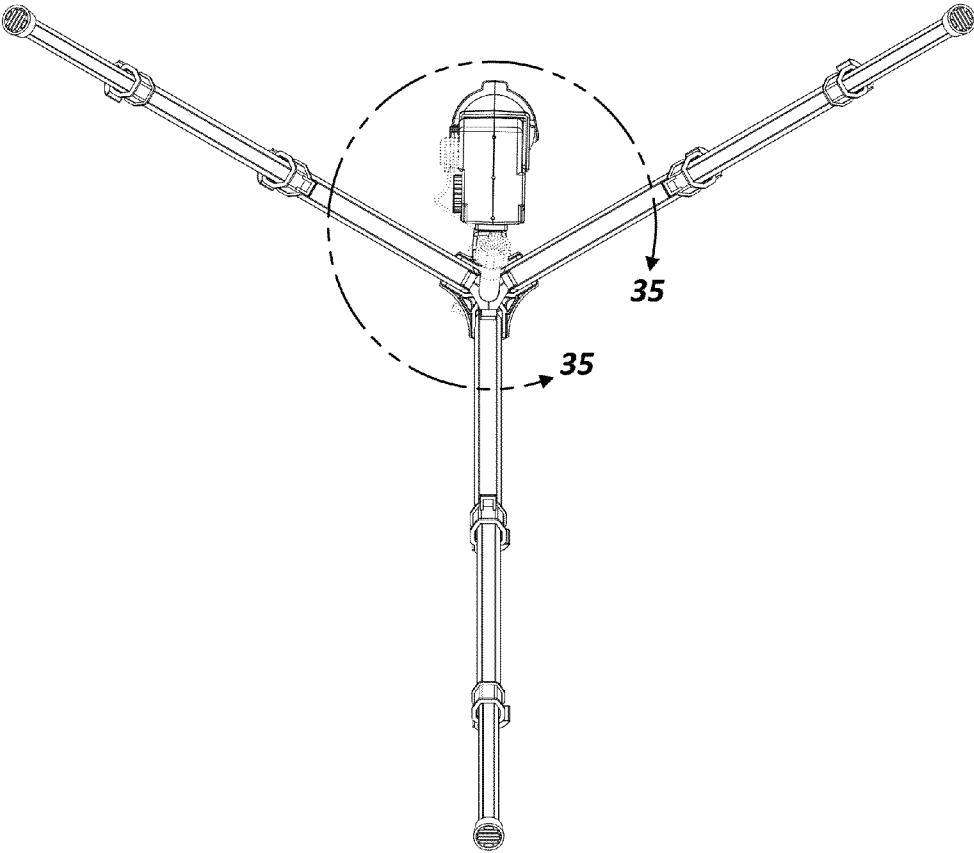

FIG. 34

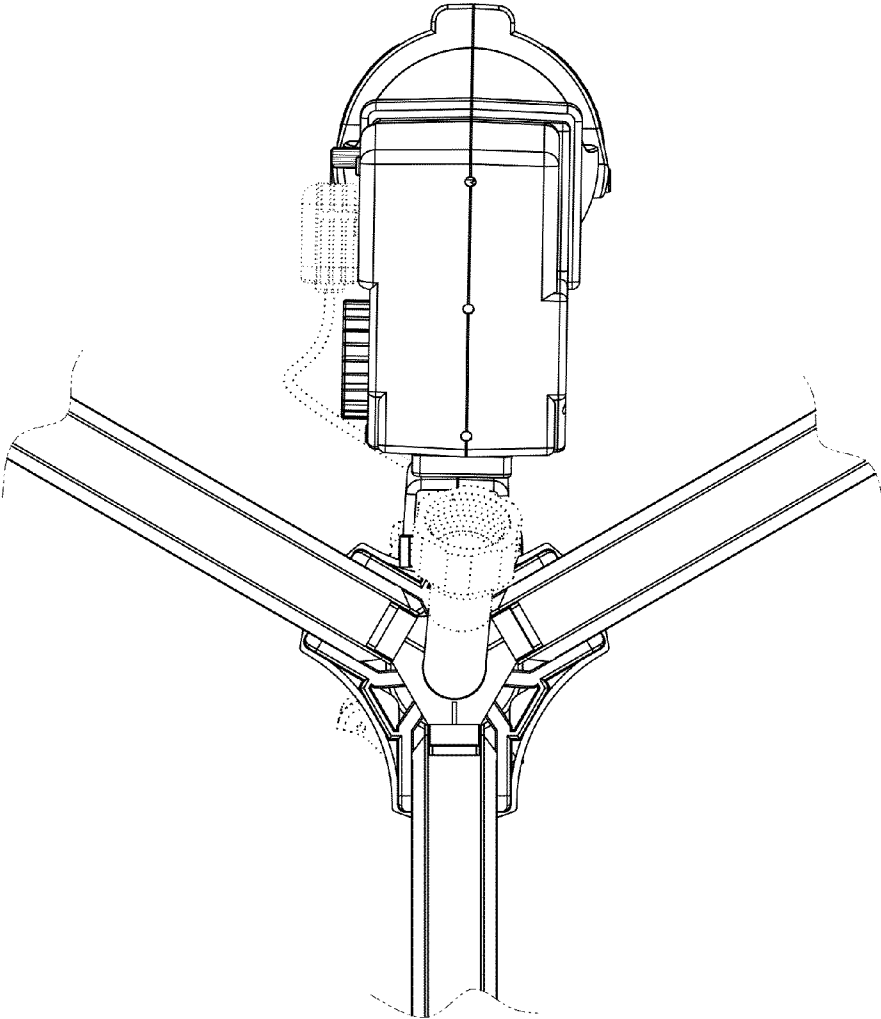

FIG. 35

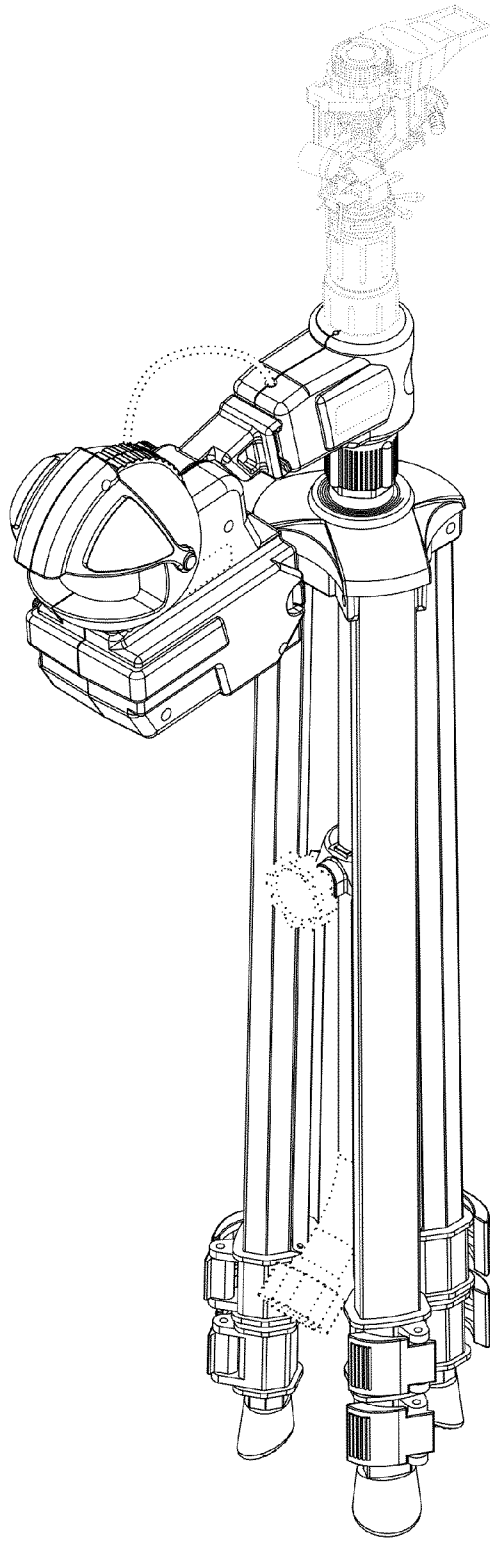

FIG. 36

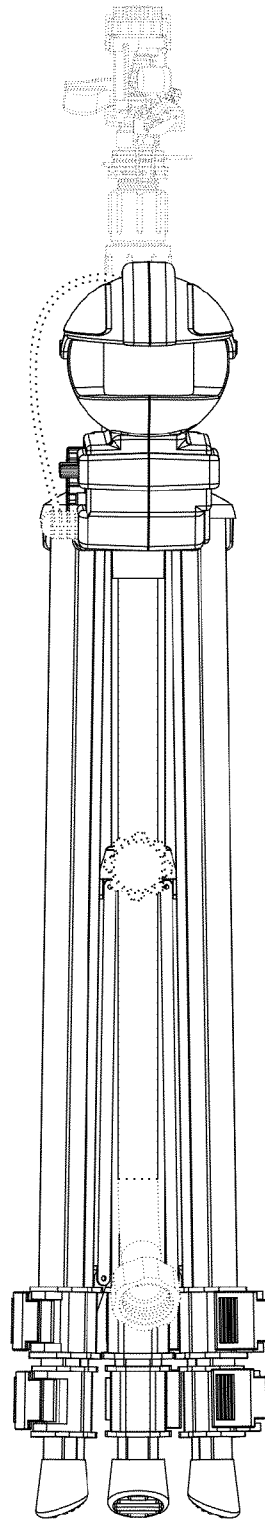

FIG. 37

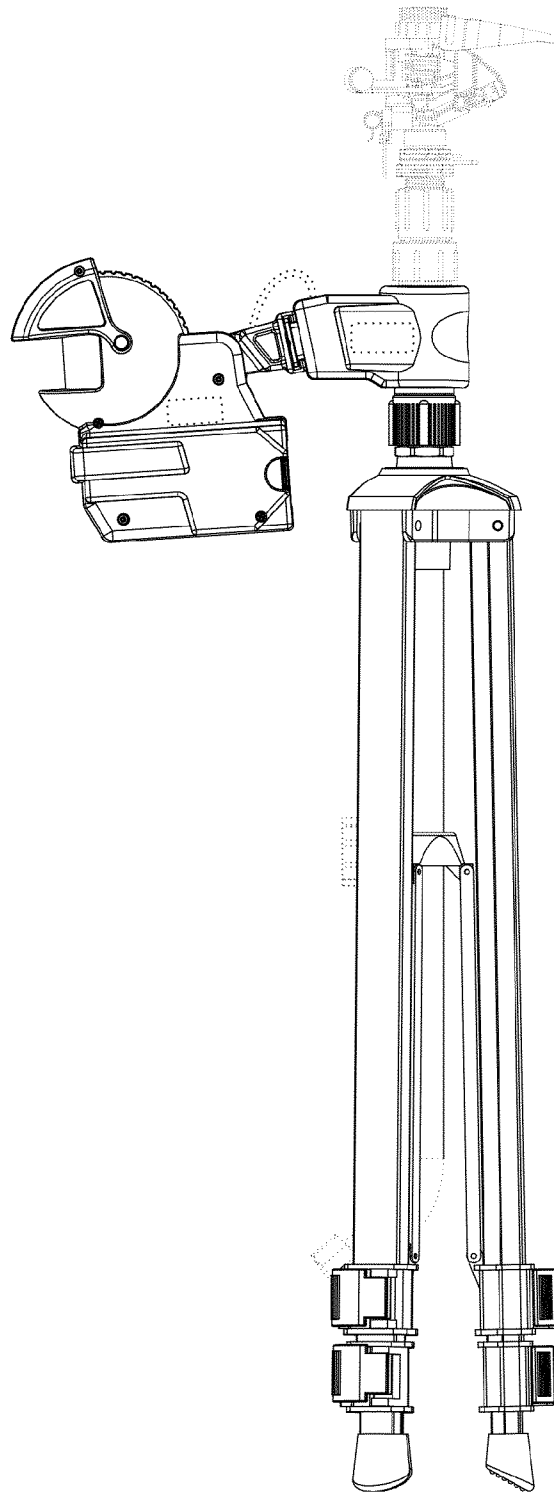

FIG. 38

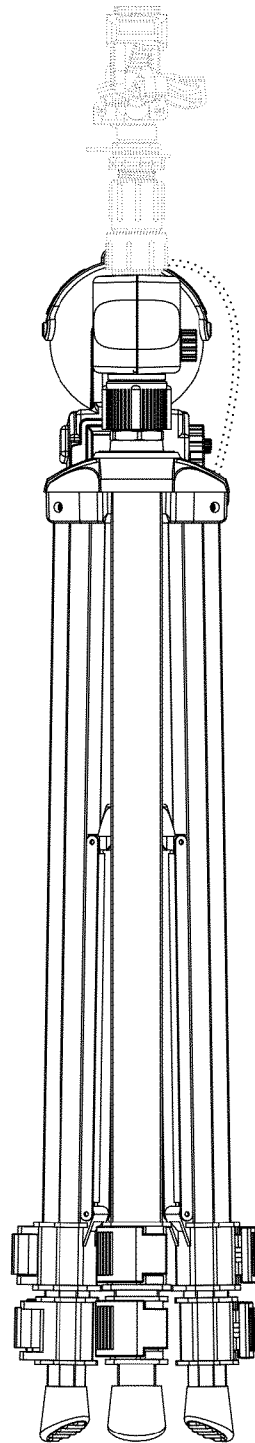

FIG. 39

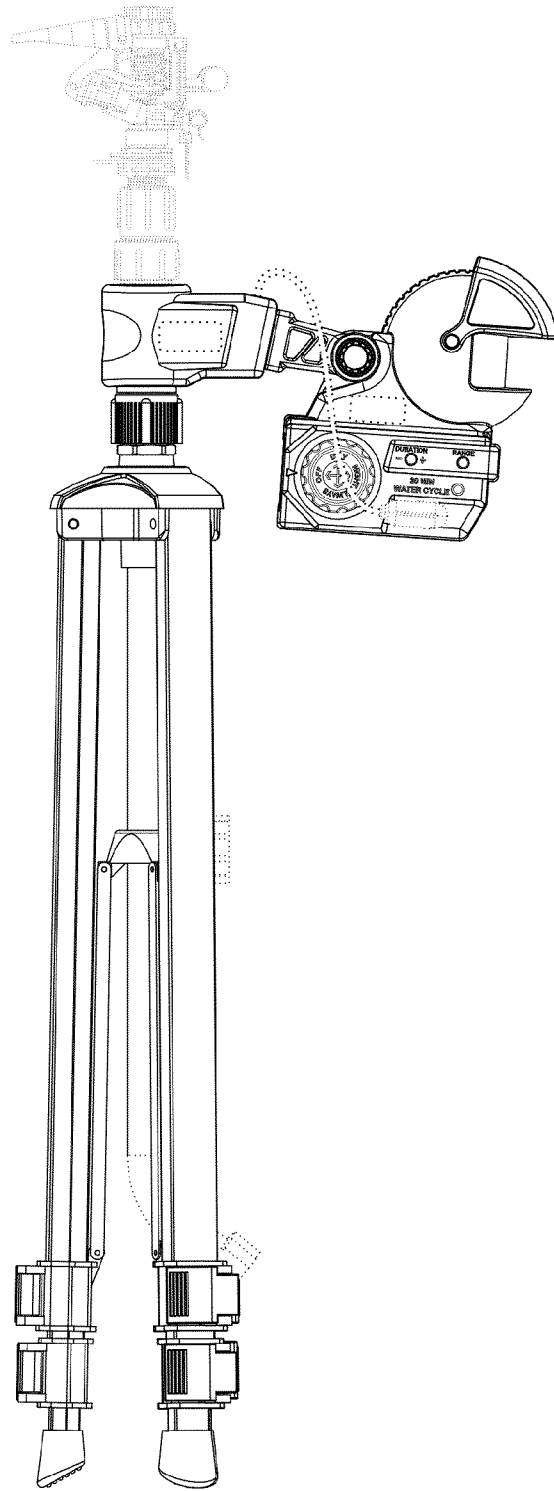

FIG. 40

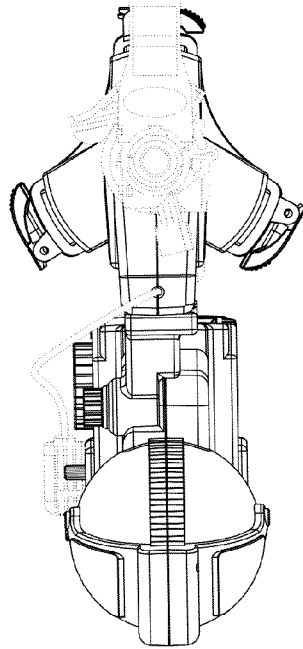

FIG. 41

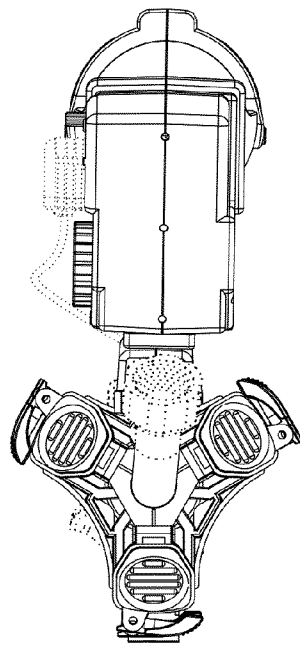

FIG. 42