



(12) EUROPEAN PATENT APPLICATION

(43) Date of publication:  
29.12.1999 Bulletin 1999/52

(51) Int. Cl.<sup>6</sup>: B65D 51/16

(21) Application number: 98116531.9

(22) Date of filing: 01.09.1998

(84) Designated Contracting States:  
AT BE CH CY DE DK ES FI FR GB GR IE IT LI LU  
MC NL PT SE  
Designated Extension States:  
AL LT LV MK RO SI

(72) Inventors:  
• Pagidas, Jannis  
14452 Metamorfofis (GR)  
• Koklas, Efstathios  
19400 Koropi (GR)  
• Stassinopoulos, Alexis  
17561 Faliron (GR)

(30) Priority: 25.06.1998 GR 98200103

(71) Applicant: ARGO SA  
19400 Koropi (GR)

(74) Representative:  
Frei, Alexandra Sarah  
Frei Patentanwaltsbüro  
Postfach 768  
8029 Zürich (CH)

(54) Semipermeable venting closure

(57) The venting cap (1) comprises a cavity (7), at least one first passage (4) for fluids connecting the cavity (7) with the inside of the container, at least one second passage (5.1, 5.2, 5) for fluids connecting the cavity (7) with the outside of the container, and a liquid-absorbing mass (8) arranged within the cavity (7). The liquid-absorbing mass (8) acts, after absorption of liq-

uid, as a selective filter prohibiting the passage of liquid, but permits the passage of gas. This ensures the fool-proof selective permeation of gas but not of liquid. Venting properties remain unaltered even at extreme conditions of transportation and storage.

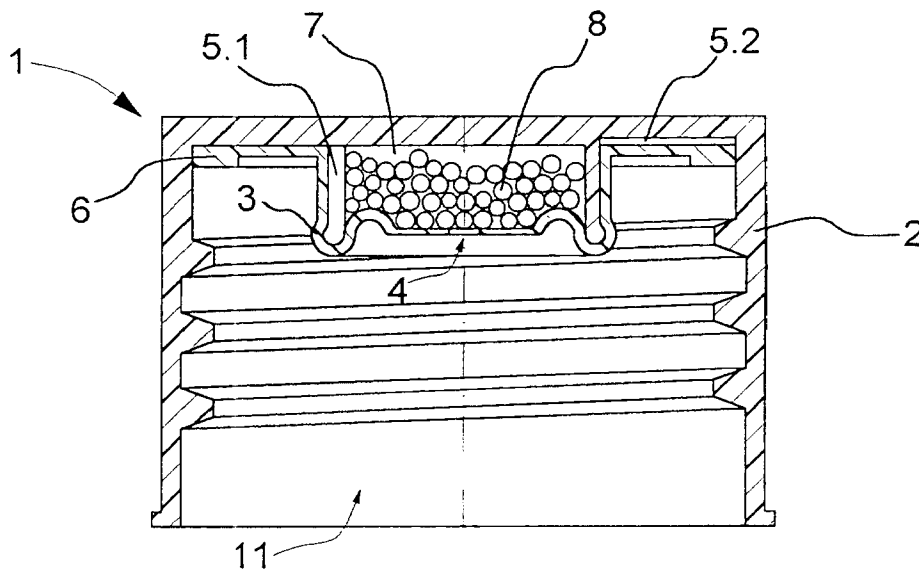

Fig. 2

## Description

[0001] The present invention relates to a semipermeable venting cap according to the preamble of the independent claim. It permits the selective passage of gases but not of the liquids, suitable to seal plastic bottles, containing liquids which could create positive or negative pressure by producing gaseous products or by absorbing air from the headspace, and to compensate pressure differences. Examples of such liquids are housecleaning and sanitation solutions, cosmetics, biochemicals, agrochemicals, beverages and liquid food products. The creation of positive or negative pressure in the plastic container causes unwanted deformation of the container.

[0002] Venting caps must be able to function properly in a wide span of end uses and storage and transportation conditions. For a wide group of consumer packages the following major prerequisites are required: (a) The caps must vent air at low pressure difference built-up. (b) They must not permit liquid exit even at high pressure built-up in the container. (c) They must retain these properties in the most extreme conditions of transportation and storage. (d) Their cost of production must be low and the materials and parts required for their manufacturing must be readily available. From the evaluation of vented cap technology available at present it was found that in all cases the vented caps proposed or offered in the market do not conform sufficiently to one or more of the above prerequisites.

[0003] Up to now the following arrangements have been tried to overcome this problem.

[0004] A first attempt was the creation of plastic bottles with very thick walls and specially design features to prevent deformation. Such bottles are expensive and environmentally non suitable because of the need to use excessive plastic material (see for example Packaging Techn. & Sci., 6 (1993), 23-29).

[0005] A second attempt was the capping of the bottles with caps fitted with porous semipermeable membranes, which permit the passage of gazes but not of liquids. The caps have suitable openings permitting the gas to exit to the environment. The major problem of this arrangement consists in the need of a much higher pressure difference to guarantee functionality, when the membrane is wet. Such caps are described in the following patents and patent applications: EP-0 408 378 (W.L. Gore), WO 94/26614 (Procter&Gamble), WO 94/22553 (W.L. Gore), DE-2 341 414 (Hesser). There are two main problems related to such caps. One is the high cost of the semipermeable membrane used and the limited sources of their supply. The other and most important problem is that when the membranes come in contact with the liquid contents (which almost always happens when the packages are transported or stored in tilted or in horizontal position) there is a change in their permeation characteristics. Thus, instead of permitting the gases to flow at low pressure differences, the

once moistened membranes require much higher pressure differences to permit gas flow. There are cases where a membrane is specified to permit gas flow at 5 mbar pressure difference which rises to 250 mbar when the membrane is wetted. To overcome this second problem, a protective cap of the membrane is proposed in EP-0 110 046 (Rhein-Conti) and in Greek patent application 960100443. Such attempts increase excessively the cost of caps.

[0006] A third attempt was the use of caps containing an outlet covered by an elastic membrane with a thin slit which would permit the exit of gas above certain pressure but impermeable to the liquid contents. Such caps are described in EP-0 555 623 GB-1 534 570, US-5,143,236 (L'Oreal), US-4,896,789 and Greek patent application 96011443. The drawback of such caps is the lack of complete selectivity in permitting the exit of gas but not of the liquid. Normally one can see liquid bubbles coming out of such caps during storage. It has been found in our experiments that the size and shape of the slit, the geometry of the elastic membrane, and the characteristics of the elastic material of the membrane are so critical that even the slightest deviation creates this non selectivity problem.

[0007] A fourth attempt where caps containing an inside elastic sealing disc, seated on a ribbed or grooved non flat surface on the underside of the cap. In theory a gas under pressure inside the bottle deforms the elastic disc and escapes through the openings created between the deformed disc and the non flat surface of the cap (US-5,242,069 (Henkel), DE-3 611 089 (Henkel), WO 94/13549 (Wazel), EP-0 241 780 (Henkel), US-5,457,943 (Hertramf)). The main drawback in such caps, in addition to their non-selectivity, is the fact that very high pressure differences are required to deform the disc (200 mbar or more). At such high pressures the plastic bottle is already deformed before the escape of gas.

[0008] The aim of the present invention is to overcome the above limitations of the up to now existing venting caps. The aim is solved by the invention as defined in the independent claims.

[0009] The herein disclosed cap is designed to permit gas escape from the contents to the environment and vice versa at very low pressure differences, even when the cap is wet. In the same time the cap is not permeable to liquid even at high pressure differences. The distinguished characteristic of the venting cap described in the present invention is the foolproof selective permeation of gas but not of liquid. The venting properties of such a cap remain unaltered even at extreme conditions of transportation and storage. This selective permeation is achieved by forcing the fluid contents, liquid or gas, to pass through a swellable liquid-absorbing mass preferably made of polymeric matrix before finding an outlet to the outside environment. No liquid is permitted to pass through this polymeric matrix after its expansion by absorption of water, contrary to the free passage of gas.

The selective free passage of gas is further improved by the inclusion of granules of a porous material in the swollen polymeric mass.

[0010] The venting cap according to the invention comprises a cavity, at least one first passage for fluids connecting the cavity with the inside of the container, at least one second passage for fluids connecting the cavity with the outside of the container, and a liquid-absorbing mass arranged within the cavity. The liquid-absorbing mass acts, after absorption of liquid, as a selective filter prohibiting the passage of liquid, but permits the passage of gas.

[0011] Further characteristics and advantages of the present invention will become apparent from the following detailed description of one preferred embodiment of the invention, illustrated by the accompanying drawings, wherein;

Fig. 1 shows a cross-section through the cap according to the invention in perspective three-dimensional view;

Fig. 2 shows a cross-section through the cap according to the invention in a front view;

Fig. 3 shows the cap according to the invention in a top view; and

Fig. 4-6 show the function of the cap according to the invention in three cross-sections.

[0012] Figure 1 shows a preferred embodiment of a semipermeable venting cap 1 according to the invention. The cap 1 is preferably made of polypropylene or other thermoplastic or thermo set materials. An inside 11 of the cap 1, comprises at least one narrow venting channel 5.1, 5.2 restricting the passage of liquid; such venting channels 5.1, 5.2 may also form a network. The inside 11 of the cap 1 is designed to form a cavity 7 for storing a liquid-absorbing mass 8 (see Fig. 2) and the fastening of an undercap 3. In the embodiment shown in Fig. 1, the cavity 7 is formed by a cylindrical ring 12 connected to the cap 1, and the undercap 3 is fitted over the ring 12. The undercap 3 is preferably made of low-density PE or other flexible material. It comprises a venting hole 4 with a diameter in the range of 0.1 to 1.5 mm which is small enough to slow down the passage of liquid contents. A cut or slot or a slot having a length in the range of 2 to 10 mm and a width in the range of width 0.01 to 0.2 mm would also be suitable to serve as the venting hole 4. In the undercap 3 a sealing ring 6 is incorporated to create air-tight sealing between the cap 2 and a container 9 (see Fig. 4).

[0013] Figure 2 shows the venting cap 1 in a front view. The cavity 7 is filled with the liquid-absorbing mass 8, e.g., water-absorbing polymeric granules. The undercap 3 acts as a cover which prevents the water-absorbing granules 8 from falling out of the cavity 7. The

narrow venting channels 5.1, 5.2 are arranged in such a manner that the adjustment of pressure difference by gas flow is supported and the flow of liquid is restricted. The cavity 7 can also be arranged in a different way but it is preferably located in a place where normally it is surrounded by gas. The venting cap 1 permits therefore the selective passage of gases but not of liquids. The water-absorbing granules 8 in the cavity 7 act as a selective filter prohibiting the passage of liquid, but permitting the passage of gas. The following swellable polymers are preferred as liquid absorbing polymeric mass: Crosslinked acrylic acid polymers and copolymers polymerized in organic solvents. Other carboxylic acids and salts used to create such polymers are metacrylic acid, malic acid and itaconic acid. To improve the rate of water absorbency, these acrylic acid polymers can be polymerized in presence of dispersed nitrogen or CO<sub>2</sub> so that polymer porous particles are formed. The liquid-absorbing mass 8 in the cavity 7 preferably has a bulk volume of 5-70 % of the volume of the cavity 7.

[0014] To further improve the selective free passage of gas, an inert organic or inorganic porous material can be included in the cavity 7. This porous material with a open surface structure creates a continuous network of channels, when in contact to each other. The ensuring of free passage of gas is guaranteed. As an example good results are obtained by the following porous materials: Aluminosilicate molecular sieve with a preferred bulk density of 750 kg/m<sup>3</sup>, a bead size of 95 % between 1 and 0.5 mm and an average pore size of 3 μm; Porous polyolefin with a preferred bulk density of 300 kg/m<sup>3</sup>, a bead size of 1-3 mm, a porosity of > 50 vol% and an average pore size of 3 μm.

[0015] Figure 3 shows the venting cap 1 in a top view. The hidden edges are dashed. The narrow venting channels 5.1, 5.2 connect the cavity 7 with the outer environment of the cap 1. As shown here the narrow channels 5.1, 5.2 are arranged in a way that their existence is not visible from the outside, which may be an advantage due to design reasons. The narrow venting channels 5.1, 5.2 can also be arranged in a different way or have a different design than in the embodiment of Fig. 1. They are optimized as to the liquid stored in the container closed by the cap 1. If more gas has to be transferred, they are designed wider. It is also possible that the narrow channels 5.1, 5.2 are temporarily sealed, if this is necessary. For certain high-quality beverages it is an advantage if they are completely sealed during a certain period. Young wines in bottles as an example need a cap which allows to equalize pressure differences during storing because of gas production. The narrow channels 5.1, 5.2 in a combination with the water-absorbing granules 8 can be designed to guarantee optimal storing to obtain best quality.

[0016] Figures 4-6 explain the operation of the invention. A container 9 is filled with a liquid product 10 (e.g., a disinfectant solution of hydrogen peroxide) and

capped with the venting cap 1. In the embodiment shown in the Figures 4-6 an opening 5 has the same function as the narrow channels 5.1, 5.2 of Figs. 1 and 2. In case where the container 9 is stored upside-down or side-down (see Fig. 5), the liquid 10 starts slowly entering into the cavity 7 through the small opening 4 of the undercap 3. This is displayed by an arrow P. The first small quantity of water solution entering the cavity 7 between cap 2 and undercap 3 swells the granules 8 of polymer, creating a mass which fills the cavity 7. This is displayed in Figs. 5 and 6, where the water absorbing granules 8 are starting to swell (see Fig. 5) filling the cavity 7 until it is completely filled (see Fig. 6). This swollen mass 8 acts from this point on as selective filter prohibiting the flow of liquid 10, but permitting the passage of gas in both directions, which is indicated by an arrow F.

**[0017]** Another application of this cap is the following. A container 9 is filled with a hot liquid 10 e.g., a hot sauce, and capped with a venting cap 1. With a normal sealing cap (not shown in detail) the walls of the bottle will be deformed after cooling. The use of the venting cap 1 according to the invention will create equalization of outside and inside pressures by permitting air to enter the bottle 9. In case that the bottle is stored side-down, the cap becomes liquid-tight due to the mechanism described in the previous example.

**[0018]** An alternative possibility is the use of the venting cap 1 with already swollen water-absorbing granules 8. A bottle 9 is filled, for an example, with an agrochemical product in organic solvent, e.g., xylene. In case that the liquid-absorbing mass 8 absorbs only water but not xylene, this embodiment would not work. In this case the problem is solved by using the venting cap 1 with pre-swollen water-absorbing granules 8. This is achieved by adding to the cavity 7 of the cap 1 the proper amount of water together with the swollen water-absorbing granules 8 before fastening the undercap 3 to the ring 12.

## Claims

1. A venting cap for a container (9) comprising  
 a cavity (7),  
 at least one first passage (4) for fluids connecting the cavity (7) with the inside of the container (9),  
 at least one second passage (5.1, 5.2, 5) for fluids connecting the cavity (7) with the outside of the container (9), and  
 a liquid-absorbing mass (8) arranged within the cavity (7), the liquid-absorbing mass (8) acting, after absorption of liquid, as a selective filter prohibiting the passage of liquid, but permitting the passage of gas.

2. The venting cap according to claim 1 wherein the

liquid-absorbing mass (8) is swellable by absorption of liquid.

3. The venting cap according to claims 1 or 2 wherein the liquid-absorbing mass (8) consists of crosslinked acrylic acid polymers and/or copolymers polymerized in organic solvents and/or other carboxylic acids and salts used to create polymers such as metacrylic acid, malic acid or itaconic acid.
4. The venting cap according to either of claims 1-3 wherein the liquid-absorbing mass (8) is polymerized in presence of dispersed nitrogen or CO<sub>2</sub> so that polymer porous particles are formed to improve the rate of water absorbency.
5. The venting cap according to either of claims 1-4 wherein the cavity (7) contains granules of an inert organic or inorganic porous material in addition to the liquid-absorbing mass (8).
6. The venting cap according to either of claims 1-5 wherein the liquid-absorbing mass (8) in the cavity (7) has a bulk volume of 5-70 % of the volume of the cavity (7).
7. The venting cap according to either of claims 1-6 wherein the first passage (4) is designed in such a way that passage of liquid is slowed.
8. The venting cap according to claim 7 wherein the first passage (4) is an opening with a diameter in the range of 0.1 to 1.5 mm or a slot having a length in the range of 2 to 10 mm and a width in the range of width 0.01 to 0.2 mm.
9. A venting cap according to either of claims 1-8 wherein the liquid-absorbing mass (8) is swollen by previously added liquid.
10. Use of the above described venting cap (1) for capping containers for cleaning fluids, sanitation solutions, agro chemicals, cosmetics, food and biological products.

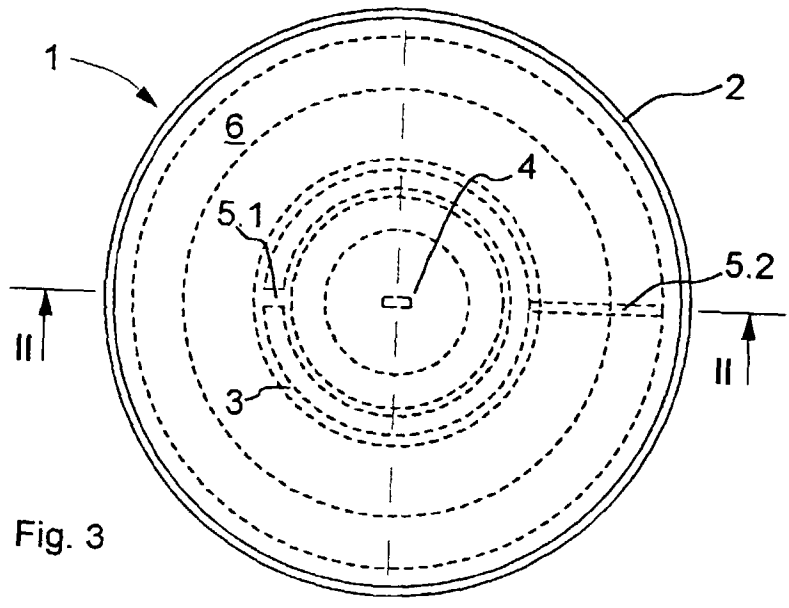
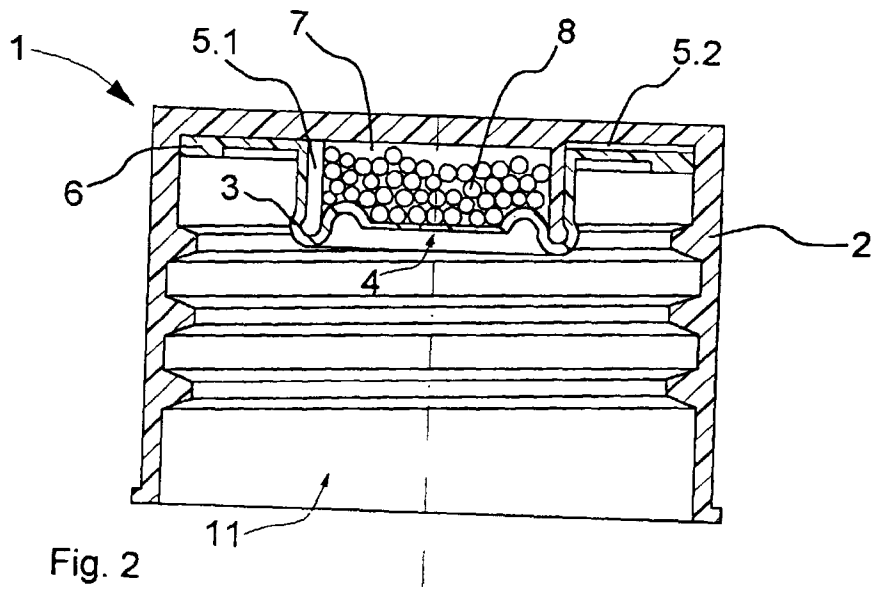
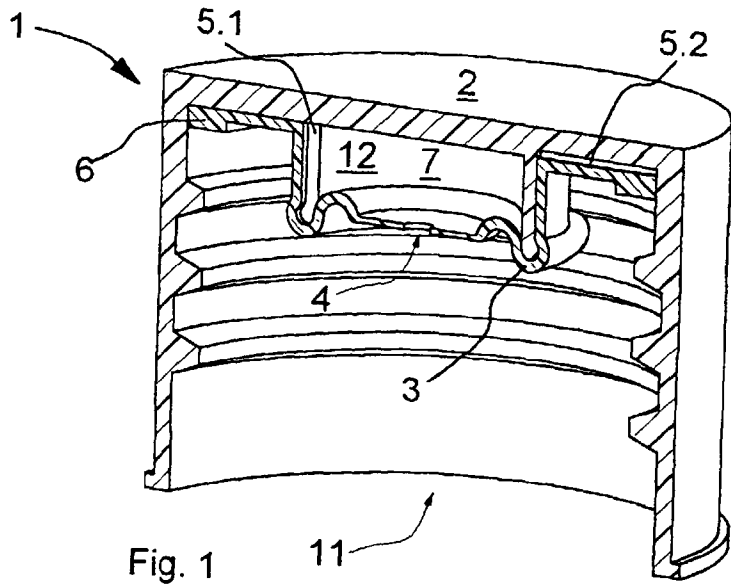

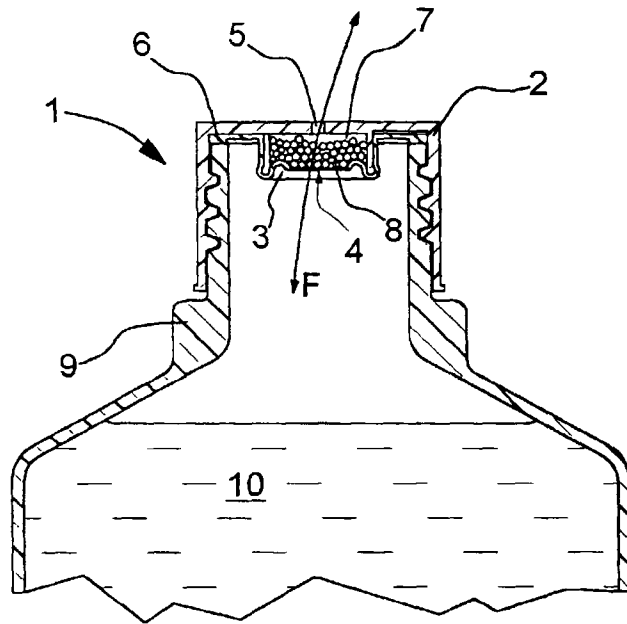

Fig. 4

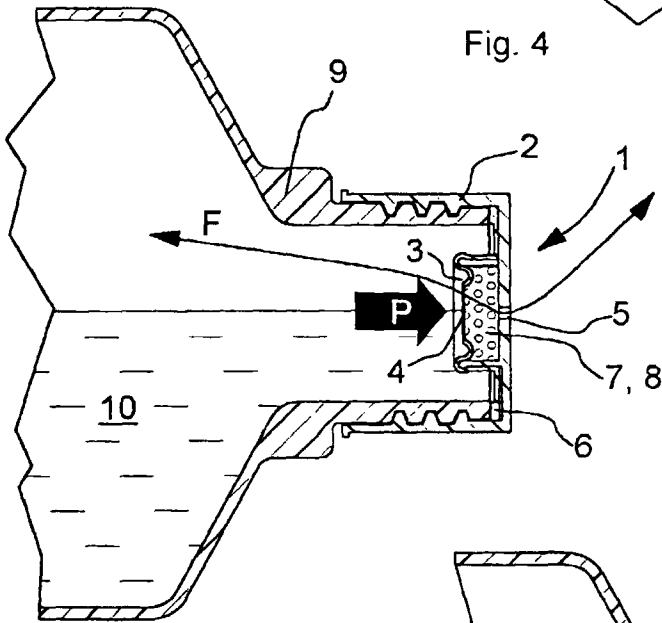

Fig. 5

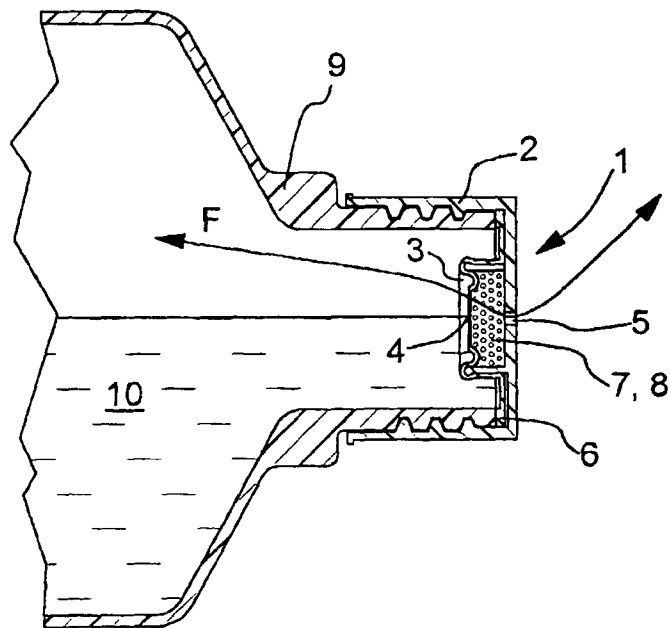

Fig. 6



European Patent  
Office

## EUROPEAN SEARCH REPORT

Application Number  
EP 98 11 6531

| DOCUMENTS CONSIDERED TO BE RELEVANT   |  |   |  |
|---|--|---|--|
| Category  | Citation of document with indication, where appropriate, of relevant passages  | Relevant to claim   | CLASSIFICATION OF THE APPLICATION (Int.Cl.6) |
| X   | EP 0 382 896 A (TECUMSEH PRODUCTS CO)<br>22 August 1990<br>* abstract; claims 1-4,7,9; figures *<br>* column 1, line 1 - line 30 *<br>* column 1, line 53 - column 2, line 22 *<br>* column 3, line 4 - line 12 *<br>* column 4, line 43 - column 5, line 42 *<br>* column 6, line 16 - column 7, line 4 * | 1,2,6,7,<br>10  | B65D51/16                                    |
| A   | ---  | 8   |  |
| X   | DE 196 33 006 A (MAUSER WERKE GMBH)<br>20 February 1997<br>* abstract; claims 1,27; figures 8,14 *<br>* column 1, line 1 - line 31 *<br>* column 2, line 5 - line 59 *<br>* column 6, line 40 - column 7, line 24 *  | 1,2,6,7,<br>10  |  |
| X   | EP 0 382 146 A (UNILEVER NV ;UNILEVER PLC<br>(GB)) 16 August 1990<br>* the whole document *  | 1,2,6,7,<br>10  |  |
| X   | EP 0 519 168 A (FROHN ERIC)<br>23 December 1992<br>* the whole document *  | 1,6,7,10  | TECHNICAL FIELDS<br>SEARCHED (Int.Cl.6)      |
| A   | ---  | 8   | B65D<br>B01D<br>B60K                         |
| A   | US 3 805 991 A (CHELADZE G ET AL)<br>23 April 1974<br>* the whole document *   | 1,2   |  |
| D,A   | EP 0 110 046 A (RHEIN CONTI KUNSTSTOFF<br>TECH) 13 June 1984<br>* the whole document *   | 1,10  |  |
| The present search report has been drawn up for all claims  |  |   |  |
| Place of search   |  | Date of completion of the search  | Examiner                                     |
| THE HAGUE   |  | 28 December 1998  | Hoornaert, P                                 |
| CATEGORY OF CITED DOCUMENTS   |  |   |  |
| X : particularly relevant if taken alone<br>Y : particularly relevant if combined with another document of the same category<br>A : technological background<br>O : non-written disclosure<br>P : intermediate document |  | T : theory or principle underlying the invention<br>E : earlier patent document, but published on, or after the filing date<br>D : document cited in the application<br>L : document cited for other reasons<br>.....<br>& : member of the same patent family, corresponding document |  |

EPO FORM 1503.03.82 (P04C01)

ANNEX TO THE EUROPEAN SEARCH REPORT  
ON EUROPEAN PATENT APPLICATION NO.

EP 98 11 6531

This annex lists the patent family members relating to the patent documents cited in the above-mentioned European search report.  
The members are as contained in the European Patent Office EDP file on  
The European Patent Office is in no way liable for these particulars which are merely given for the purpose of information.

28-12-1998

| Patent document<br>cited in search report |   | Publication<br>date | Patent family<br>member(s)  | Publication<br>date  |
|---|---|---------------------|---|--|
| EP 0382896                                | A | 22-08-1990          | US 4884716 A<br>CA 1319646 A  | 05-12-1989<br>29-06-1993   |
| DE 19633006                               | A | 20-02-1997          | DE 29513256 U<br>DE 29615523 U<br>DE 29623363 U<br>EP 0759401 A                             | 07-12-1995<br>12-12-1996<br>30-07-1998<br>26-02-1997                             |
| EP 0382146                                | A | 16-08-1990          | DE 3903509 A<br>AU 630149 B<br>AU 4900590 A<br>ES 2042091 T<br>JP 2269666 A<br>JP 2742315 B | 09-08-1990<br>22-10-1992<br>09-08-1990<br>01-02-1997<br>05-11-1990<br>22-04-1998 |
| EP 0519168                                | A | 23-12-1992          | DE 9107432 U<br>DE 9112190 U<br>DE 59202439 D   | 22-08-1991<br>05-12-1991<br>13-07-1995   |
| US 3805991                                | A | 23-04-1974          | NONE  |  |
| EP 0110046                                | A | 13-06-1984          | DE 8233621 U  | 03-02-1983   |