

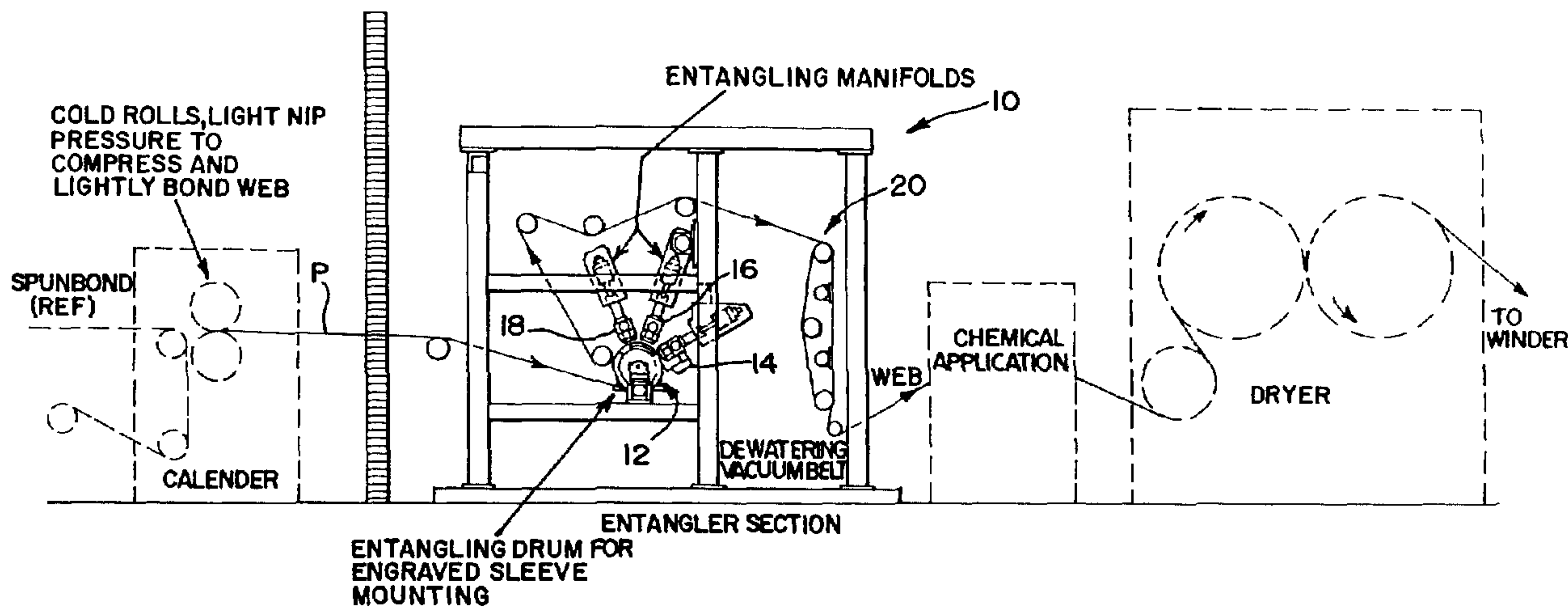

(86) Date de dépôt PCT/PCT Filing Date: 2001/01/12
 (87) Date publication PCT/PCT Publication Date: 2002/07/18
 (45) Date de délivrance/Issue Date: 2009/07/07
 (85) Entrée phase nationale/National Entry: 2002/08/12
 (86) N° demande PCT/PCT Application No.: US 2001/001167
 (87) N° publication PCT/PCT Publication No.: 2002/055781

(51) Cl.Int./Int.Cl. *D04H 3/10* (2006.01)
 (72) Inventeurs/Inventors:
 PUTNAM, MICHAEL, US;
 FERENCZ, RICHARD, US;
 STORZER, MARLENE, US;
 WENG, JIAN, US
 (73) Propriétaire/Owner:
 POLYMER GROUP, INC., US
 (74) Agent: STIKEMAN ELLIOTT LLP

(54) Titre : TISSU NON TISSE DE FAIBLE POIDS SURFACIQUE A FIBRES ENCHEVETREES PAR PROCEDE
 HYDRAULIQUE ET PROCEDE DE FABRICATION
 (54) Title: HYDROENTANGLED, LOW BASIS WEIGHT NONWOVEN FABRIC AND PROCESS FOR MAKING SAME



(57) Abrégé/Abstract:

A process is disclosed for hydroentangling polymeric filament webs for production of low basis weight nonwoven fabrics. A hydroentangling device having a foraminous forming surface (12) is employed for hydroentangling a precursor web (P) to form a fabric. High-speed production of relatively low basis weight fabrics can be achieved, with the fabrics exhibiting desired softness, uniformity, and strength characteristics.

(12) INTERNATIONAL APPLICATION PUBLISHED UNDER THE PATENT COOPERATION TREATY (PCT)

(19) World Intellectual Property Organization
International Bureau



(43) International Publication Date
18 July 2002 (18.07.2002)

PCT

(10) International Publication Number
WO 02/055781 A1

- (51) International Patent Classification⁷: **D04H 3/10**
- (21) International Application Number: PCT/US01/01167
- (22) International Filing Date: 12 January 2001 (12.01.2001)
- (25) Filing Language: English
- (26) Publication Language: English
- (71) Applicant: **POLYMER GROUP, INC.** [US/US]; 4838 Jenkins Avenue, North Charleston, SC 29406 (US).
- (72) Inventors: **PUTNAM, Michael**; 7105 Niblick Court, Fuquay-Varina, NC 27526 (US). **FERENCZ, Richard**; 4 Seahorse Court, Ilse of Palms, SC 29451 (US). **STORZER, Marlene**; 19115 Spring Blossom Lane, Cornelius, NC 28031 (US). **WENG, Jian**; 4819 Fairvista Drive, Charlotte, NC 28269 (US).
- (74) Agent: **GEIMER, Stephen, D.**; Rockey, Milnamow & Katz, Ltd., Suite 4700, Two Prudential Plaza, 180 North Stetson, Chicago, IL 60601 (US).
- (81) Designated States (*national*): AE, AG, AL, AM, AT, AU, AZ, BA, BB, BG, BR, BY, BZ, CA, CH, CN, CR, CU, CZ, DE, DK, DM, DZ, EE, ES, FI, GB, GD, GE, GH, GM, HR, HU, ID, IL, IN, IS, JP, KE, KG, KP, KR, KZ, LC, LK, LR, LS, LT, LU, LV, MA, MD, MG, MK, MN, MW, MX, MZ, NO, NZ, PL, PT, RO, RU, SD, SE, SG, SI, SK, SL, TJ, TM, TR, TT, TZ, UA, UG, UZ, VN, YU, ZA, ZW.
- (84) Designated States (*regional*): ARIPO patent (GH, GM, KE, LS, MW, MZ, SD, SL, SZ, TZ, UG, ZW), Eurasian patent (AM, AZ, BY, KG, KZ, MD, RU, TJ, TM), European patent (AT, BE, CH, CY, DE, DK, ES, FI, FR, GB, GR, IE, IT, LU, MC, NL, PT, SE, TR), OAPI patent (BF, BJ, CF, CG, CI, CM, GA, GN, GW, ML, MR, NE, SN, TD, TG).
- Published:**
— with international search report
- For two-letter codes and other abbreviations, refer to the "Guidance Notes on Codes and Abbreviations" appearing at the beginning of each regular issue of the PCT Gazette.

(54) Title: HYDROENTANGLED, LOW BASIS WEIGHT NONWOVEN FABRIC AND PROCESS FOR MAKING SAME

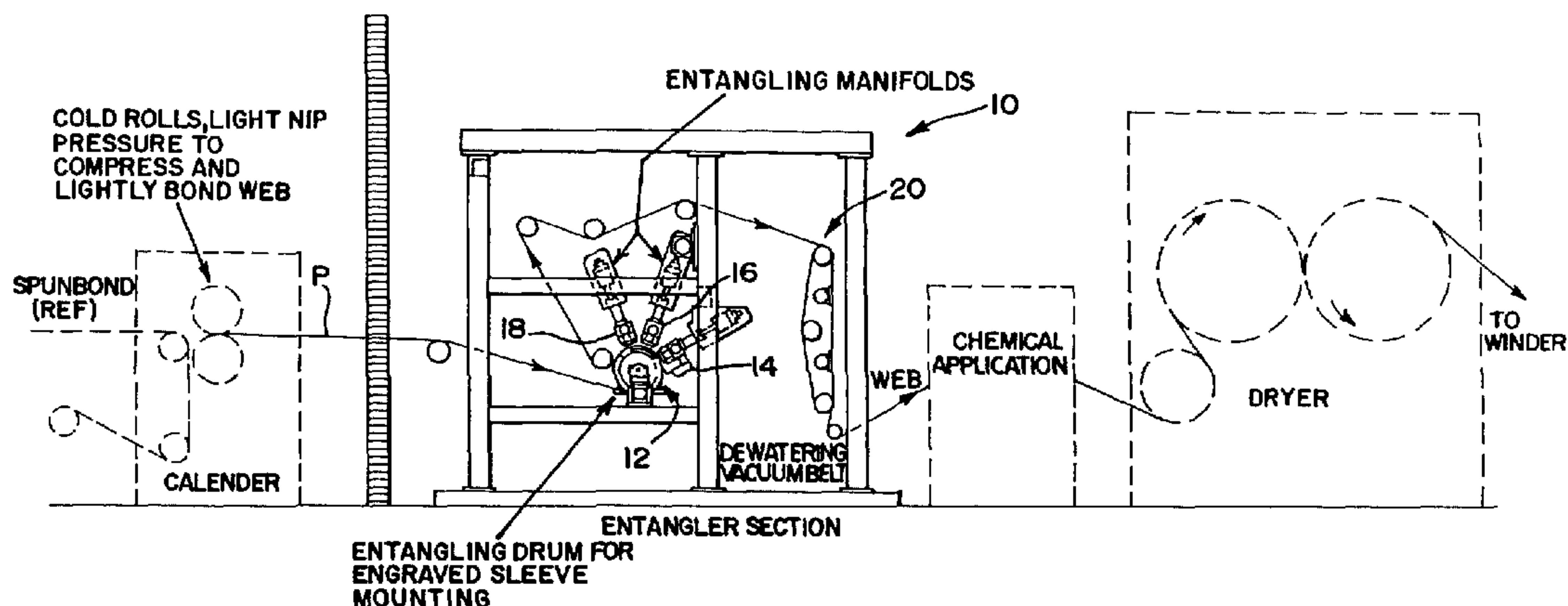

(57) Abstract: A process is disclosed for hydroentangling polymeric filament webs for production of low basis weight nonwoven fabrics. A hydroentangling device having a foraminous forming surface (12) is employed for hydroentangling a precursor web (P) to form a fabric. High-speed production of relatively low basis weight fabrics can be achieved, with the fabrics exhibiting desired softness, uniformity, and strength characteristics.

WO 02/055781 A1

HYDROENTANGLED, LOW BASIS WEIGHT
NONWOVEN FABRIC AND PROCESS FOR MAKING SAME

Technical Field

5 The present invention relates generally to nonwoven fabrics, and a method for producing such fabrics, and more particularly to a hydroentangled, low basis weight nonwoven fabric exhibiting desirable softness and strength characteristics, with manufacture from a lightly bonded precursor web facilitating efficient and high-speed production.

Background Of The Invention

10 Nonwoven fabrics are used in a wide variety of applications where the engineered qualities of the fabric can be advantageously employed. These types of fabrics differ from traditional woven or knitted fabrics in that the fibers or filaments of the fabric are integrated into a coherent web without traditional textile processes. Entanglement of the fibrous elements of the fabric provides the fabric with the desired integrity, with the selected
15 entanglement process permitting fabrics to be patterned to achieve desired aesthetics.

Various prior art patents disclose techniques for manufacturing nonwoven fabrics by hydroentangling processes. U.S. Patent No. 3,485,706, to Evans discloses a hydroentanglement process for manufacture of nonwoven fabrics. Hydroentanglement entails the application of high-pressure water jets to webs of fibers or filaments, whereby the
20 fivers or filaments are rearranged under the influence of water impingement. The web is typically positioned on a foraminous forming surface as it is subjected to impingement by the water jets, whereby the fibers or filaments of the web become entangled, thus creating a fabric with coherency and integrity, while the specific features of the forming surface act to create the desired pattern in the nonwoven fabric. However, there is no teaching or
25 suggestion in Evans '706 to form a fabric upon a three-dimensional forming surface.

Heretofore, typical hydroentanglement of relatively low basis weight fabrics with the Evans-type technology has been problematic. At low basis

weights (on the order of less than 30 grams per square meter), there are a relatively low number of fibers or filaments present for entangling, thus making entanglement relatively inefficient. Entanglement of these light basis weight webs on traditional forming surfaces taught by Evans and its progeny tends to "wash" the low fiber content webs, rearranging the fibers in a fashion which undesirably results in a non-uniform product. Entanglement of these low basis weight webs at relatively high processing speeds compounds the problem of maintaining uniformity, because the impinging water jet flows and/or pressures must be relatively increased, which increases the undesirable tendency to distort the web. Further, the high energy jets required by high speed entangling processes tend to drive the fibers into the drain hole openings of the foraminous surface, or into the interstitial spaces of a woven forming wire. This creates serious difficulties with web transfer.

U.S. Patent No. 5,369,858, to Gilmore et al., discloses a process for forming apertured nonwoven fabric from melt-blown microfibers using the Evans-type technology. These types of fibers are attenuated during known melt-blowing formation techniques, whereby the fibers have relatively small diameters. This patent discloses the use of a belt or drum forming surface having a perforated or foraminated forming surface. Plural hydroentangling manifolds act against fibers positioned on the forming surface to displace the fibers from "knuckles" of the forming surface, and into openings or lower parts of the forming surface topography, as in Evans. This patent contemplates use of a polymeric net or scrim for fabric formation, and the formation of fabric having apertures therein of two different sizes, including formation of fabric from a first layer of textile fibers or polymeric filaments, and a second layer of melt-blown microfibers.

U.S. Patent No. 5,516,572, to Roe, discloses a disposable absorbent article including a liquid pervious topsheet, wherein the topsheet comprises a nonwoven fabric prepared from a homogeneous admixture of melt-blown fibers and staple length synthetic fibers. The patent contemplates that fabrics formed

in accordance with its teachings comprise a blend including up to 50% by weight of melt-blown fibers.

U.S. Patent No. 4,805,275, to Suzuki et al., also discloses a method for forming nonwoven fabrics by hydroentanglement. This patent contemplates that hydroentanglement of a fibrous web be effected on a non-three-dimensional smooth-surfaced water-impermeable endless belt, but notes that at fabric weights below 15 grams per square meter that irregularities in the fibrous web occur, and fabrics with substantial uniformity cannot be obtained.

In contrast to the above-referenced patents, the present invention contemplates a process employing a hydroentangling device having a foraminous forming surface for forming relatively low basis weight nonwoven fabrics, which can be efficiently practiced for manufacture of fabrics having a high degree of uniformity. Such uniformity facilitates use of such fabrics in a wide variety of applications, with efficient formation facilitating economical use.

Summary Of The Invention

A process of making a nonwoven fabric having a low basis weight in accordance with the principles of the present invention contemplates hydroentangling on a device having a foraminous forming surface of a precursor web comprising spunbonded continuous polymeric filaments. As is known in the art, spunbonding entails extrusion or "spinning" of thermoplastic polymeric material with the resultant filaments cooled and drawn or attenuated as they are collected. The continuous, or essentially endless, filaments may be bonded, with the process of the subject invention contemplating that such spunbonded material be employed as the precursor web.

To form relatively low basis weight fabrics, a precursor web having a basis weight from about 10 to about 30 grams per square meter is employed. The present invention further contemplates that an image transfer device be provided, with the transfer device having a fabric-forming surface.

With the precursor web positioned on the hydroentangling device, hydroentanglement is effected by application of high pressure liquid streams to the web. Filaments of the web are rearranged on the fabric-forming surface of the device. The forming surface of the device, thus acts in concert with the high pressure liquid streams, to rearrange the filaments of the precursor web.

A low basis weight web formed in accordance with the present invention comprises a web of hydroentangled polymeric filaments having a denier from 0.2 to 3.0. The filaments are arranged in a substantially uniform matrix.

Notably, the characteristics of the spunbonded precursor web, in particular the strength of its bonds, has a direct influence on the strength characteristics of the resultant low basis weight fabric. Development has shown that if the spunbond precursor web is only relatively lightly bonded, hydroentanglement acts to break or disrupt the bonds without substantially breaking the continuous filaments from which the spunbond precursor web is formed. As a consequence, a low basis weight fabric formed in accordance with the present invention may be formed to include substantially continuous filaments (from a relatively lightly bonded spunbond precursor web), with the resulting fabric having a machine direction tensile strength of at least about 1,472 grams per centimeter at 47% machine-direction elongation. The degree of bonding of the precursor web is specifically selected to facilitate handling of the web, with the contemplation that higher strength fabrics can be achieved if the filaments of the precursor web are maintained in a substantially continuous form. In accordance with the present invention, it is contemplated that the spunbond precursor web is subjected to bonding which provides no more than a minimum tensile strength which permits winding and unwinding of the precursor web. Thus, the minimal tensile strength of the precursor web is selected to facilitate efficient handling during manufacturing of the present low basis weight nonwoven fabric.

Other features and advantages of the present invention will become readily apparent from the following detailed description, the accompanying drawings, and the appended claims.

Brief Description Of The Drawing

5 FIGURE 1 is a diagrammatic view of a hydroentangling apparatus for practicing the process of the present invention, whereby low basis weight nonwoven fabrics embodying the principles of the present invention can be formed.

Detailed Description

10 While the present invention is susceptible of embodiment in various forms, there is shown in the drawings and will hereinafter be described a presently preferred embodiments, with the understanding that the present disclosure is to be considered as an exemplification of the invention, and is not intended to limit the invention to the specific embodiment illustrated.

15 With reference to FIGURE 1, therein is illustrated a hydroentangling apparatus, generally designated 10, which can be employed for practicing the process of the present invention for manufacture of a relatively low basis weight nonwoven fabric. The apparatus is configured generally in accordance with the teachings of U.S. Patent No. 5,098,764, to Drelich et al., hereby incorporated by reference. The apparatus 10 includes an entangling drum 12 which comprises a hydroentangling device having a foraminous forming surface
20 upon which hydroentangling of a precursor web is effected for formation of the present nonwoven fabric.

In the presently preferred practice of the present invention, a standard 23-mesh bronze wire screen is employed for the forming surface of entangling drum 12.

25 In the apparatus illustrated in FIGURE 1, a plurality of hydroentangling manifolds, designated 14, 16, and 18, act sequentially upon a precursor web P trained about entangling drum 12. The precursor web P may be formed in-line with the entanglement apparatus, as generally illustrated in phantom line, or may

be provided in the form of rolls of material fed into the entangling apparatus for processing.

While it is within the purview of the present invention to employ various types of precursor webs, including fibrous and continuous filament webs, it is presently preferred to employ spunbonded continuous filament webs comprising
5 polymeric filaments, preferably polyester (polyethylene terephthalate). Filament denier is preferably 0.2 to 3.0, with 1.5 denier filaments being particularly preferred. The precursor web preferably has a basis weight from about 10 to 30
10 grams per square meter, more preferably from about 15 to 20 grams per square meter. Use of continuous filament precursor webs is presently preferred because the filaments are essentially endless, and thus facilitate use of relatively high energy input during entanglement without undesirably driving filaments into the image transfer device, as can occur with staple length fibers or the like. The preferred use of filamentary precursor webs permits the filament to be subjected
15 to elevated hydraulic energy levels without undesirable fouling of the forming surface. Thus, fabrics are formed without substantially altering the basis weight of the precursor webs.

A particular benefit of finished fabrics formed in accordance with the present invention is uniformity of patterning. Fiber movement from the water
20 jets from the hydroentangling manifolds is controlled by the shape and depth of the forming surface and drainage design. The use of higher pressures and flows is desirably achieved, thus permitting processing of webs at high speeds and low basis weights. Finished products in the 10 to 30 grams per square meter range are produced at operating speeds up to hundreds of feet per minute.

25 The following is an example of a low basis weight nonwoven fabric formed in accordance with the present invention. Reference to manifold pressures is in connection with water pressure, in pounds per square inch (psi), in the successive hydroentangling manifolds 14, 16, and 18, illustrated in FIGURE 1. Each of these manifolds included orifice strips having 33.3 holes or
30 orifices per inch, each having a diameter of 0.0059 inches. The example was

made using a single pass beneath the hydroentangling manifolds, with each manifold acting against the same side of the precursor web to form the resultant fabric. Testing of fabrics was conducted in accordance with ASTON testing protocols.

5 A lightly bonded precursor web, as referenced below, may be produced on a commercial spunbond production line using standard processing conditions, except thermal point bonding calender temperatures are reduced, and may be at ambient temperature (sometimes referred to as cold calendering). For example, during production of standard polyester spunbond, the thermal point bonding
10 calender is set at a temperature of 200 to 210 degrees C. to produce the bonded finished product. In contrast, to prepare a similar precursor web for subsequent entangling and imaging, the calender temperature is reduced to 160 degrees C. Similarly, during production of standard polypropylene spunbond products, the common thermal point calender conditions are 300 degrees F., and 320 pounds
15 per linear inch (PLI) nip pressure. For a lightly bonded polypropylene precursor web to be entangled and imaged, these conditions are reduced to 100 degrees F. and 100 PLI.

Example 1

20 A relatively lightly bonded spunbond polyester precursor web was employed having a basis weight of 28 grams per square meter, with 1.8 denier filaments. The precursor was lightly bonded as described above. The precursor web was entangled at 80 feet per minute, with successive manifold pressures of 700, 4,000, and 4,000 psi. A standard 23-mesh bronze wire forming surface was employed. Energy input was 3.2 horsepower-hour per pound. The resultant
25 fabric exhibited a basis weight of 32.4 grams per square meter, a bulk of 0.470 millimeter, a cross-direction strip tensile strength of 327 grams per centimeter, at a cross-direction elongation of 72%, and a machine direction strip tensile strength of 1,472 grams per centimeter at a machine direction elongation of 47%.

It will be noted from the above that Example 1 exhibited relatively high tensile strength characteristics. It has been observed that this is a result of the degree of bonding of the precursor web for the various examples. In Example 1, a relatively lightly bonded precursor web was employed and it is believed that when this type of web is subjected to hydroentanglement, there is a breakage or disruption of the bonds without significant breakage of the polymeric filaments of the precursor web. In contrast, precursor webs which were used during development which were relatively well-bonded, exhibited less strength. It is believed that during hydroentanglement, disruption and breakage of the filament bonds resulted in a relatively higher degree of filament breakage.

Fabrics formed in accordance with the present invention are desirably lightweight, exhibiting desirable softness and bulk characteristics. Fabrics produced in accordance with the present invention are useful for nonwoven disposable products such as diaper facing layers, with the present fabrics exhibiting improved softness compared to typical spunbonded materials. The present fabrics are preferable to thermally bonded lightweight webs, which tend to be undesirably stiff. It is believed that fabrics in accordance with the present invention can be readily employed in place of traditional point bonded and latex bonded nonwoven fabrics, dependent upon basis weight and performance requirements.

The precursor web used in the above Example which was characterized as lightly bonded were formed as specified, whereby the precursor web was bonded to exhibit no more than a minimal tensile strength which permits winding and unwinding of the web. If hydroentanglement is effected in-line with production of a spunbond precursor web, the precursor web may be lightly bonded a sufficient degree as to permit efficient movement of the precursor web into the hydroentangling apparatus.

As illustrated in FIGURE 1, subsequent to hydroentanglement, the fabric being formed may be subjected to dewatering, as generally illustrated at 20, with chemical application (if any) and typical drying of the fabric thereafter effected.

From the foregoing, it will be observed that numerous modifications and variations can be effected without departing from the true spirit and scope of the novel concept of the present invention. It is to be understood that no limitation with respect to the specific embodiment illustrated herein is intended or should
5 be inferred. The disclosure is intended to cover, by the appended claims, all such modifications as fall within the scope of the claims.

WHAT IS CLAIMED IS:

1. A process for making a nonwoven fabric having a low basis weight, comprising the steps of:

providing a hydroentangling device having a foraminous fabric-forming surface;

5 positioning a precursor web having a length on said device, wherein said precursor web comprises continuous polymeric filaments, said precursor web having a basis weight from about 10 to about 30 grams per square meter; and

hydroentangling said precursor web to form said low basis weight fabric by application of high pressure liquid streams thereto so that the filaments of said web are
10 rearranged on the fabric-forming surface of said device,

said precursor web being hydroentangled at a rate of at least 80 feet/minute in a direction along the length of said web, without substantially altering the basis weight of said precursor web; and

removing the low basis weight fabric from said fabric-forming surface.

15 2. A process for making a low basis weight nonwoven fabric in accordance with claim 1, wherein:

said hydroentangling device comprises a 23-mesh forming screen.

3. A process for making a low basis weight nonwoven fabric in accordance with claim 1, wherein:

20 said precursor web comprises bonded, continuous polymeric filaments.

4. A process for making a low basis weight fabric in accordance with claim 3, wherein

said precursor web is bonded with no more than minimum tensile strength which permits winding and unwinding of said precursor web.

5. A process for making a low basis weight fabric in accordance with claim 4, wherein:

25 during said hydroentangling step, bonds in said precursor web are broken to unbond said continuous polymeric filaments while minimizing breakage of said filaments.

6. A process of making a nonwoven fabric having a low basis weight, comprising the steps of:

5 providing a precursor web having a length, said precursor web comprising spunbonded continuous polymeric filaments, and having a basis weight from about 10 to about 30 grams per square meter;

providing a hydroentangling device having a foraminous forming surface;

positioning said precursor web on said hydroentangling device;

10 hydroentangling said precursor web to form a low basis weight fabric by application of high pressure liquid streams thereto so that bonds between said filaments are broken, and the filaments rearranged on the foraminous forming surface, and

removing said fabric from said hydroentangling device.

7. A process of making a nonwoven fabric having a low basis weight in accordance with claim 6, wherein:

15 said low basis weight fabric has a machine direction tensile strength of at least about 1,472 grams per centimeter.

8. A process of making a nonwoven fabric having a low basis weight in accordance with claim 7, wherein:

said hydroentangling device comprises a wire mesh forming surface.

9. A process for making a nonwoven fabric having a low basis weight, comprising the steps of:

20 providing a hydroentangling device having a foraminous fabric-forming surface;

positioning a precursor web having a length on said device, wherein said precursor web consists of relatively lightly bonded continuous polymeric filaments, said precursor web having a basis weight from about 10 to about 30 grams per square meter; and

25 hydroentangling said precursor web to form said low basis weight fabric by application of high pressure liquid streams thereto so that bonds between polymeric elements of said precursor web are broken to unbond the filaments, and the filaments of said web are rearranged on the fabric-forming surface of said device,

said precursor web being hydroentangled at a rate of at least 80 feet/minute in a direction along the length of said web, without substantially altering the basis weight of said precursor web; and

removing the low basis weight fabric from said fabric-forming surface.

- 5 10. A process of making a nonwoven fabric having a low basis weight in accordance with claim 4, wherein:

said low basis weight fabric has a machine direction tensile strength of at least about 1,472 grams per centimeter.

- 10 11. A process of making a nonwoven fabric having a low basis weight in accordance with claim 5, wherein:

said hydroentangling device comprises a wire mesh forming surface.

FIG. 1

