

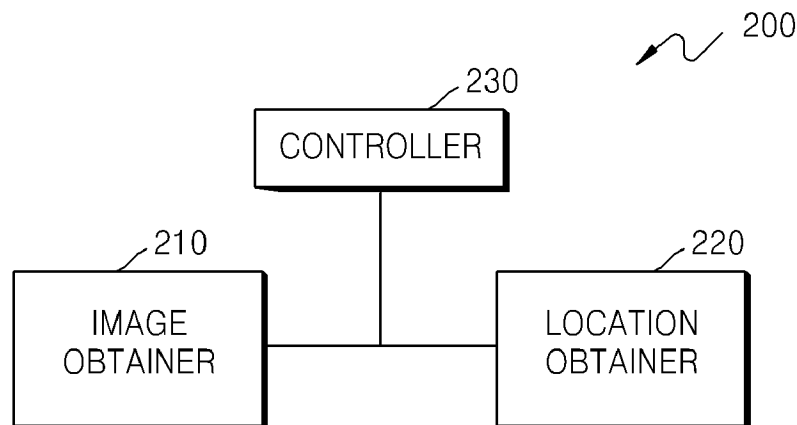

- (51) International Patent Classification:
H04N 5/262 (2006.01) *A61B 6/00* (2006.01)
- (21) International Application Number:
PCT/KR2013/006548
- (22) International Filing Date:
23 July 2013 (23.07.2013)
- (25) Filing Language: English
- (26) Publication Language: English
- (30) Priority Data:
10-2012-0099547
7 September 2012 (07.09.2012) KR
10-2013-0026812 13 March 2013 (13.03.2013) KR
- (71) Applicant: SAMSUNG ELECTRONICS CO., LTD.
[KR/KR]; 129, Samsung-ro, Yeongtong-gu, Suwon-si,
Gyeonggi-do 443-742 (KR).
- (72) Inventors: MOON, Hee-yeon; 109-1304 Neulpureun By-
oksan Apt., Mangpo-dong, Yeongtong-gu, Suwon-si,
Gyeonggi-do 443-707 (KR). SHIN, Seung-hoon; #102 56-
7, Gumi-dong, Bundang-gu, Seongnam-si, Gyeonggi-do
463-808 (KR). HAN, Woo-sup; 221-1804 Sin LG 2-cha
Apt., Sinbong-dong, Suji-gu, Yongin-si, Gyeonggi-do 448-
534 (KR).
- (74) Agent: Y.P.LEE, MOCK & PARTNERS; 12F Daelim
Acrotel, 13 Eonju-ro 30-gil, Gangnam-gu, Seoul 135-971
(KR).
- (81) Designated States (unless otherwise indicated, for every
kind of national protection available): AE, AG, AL, AM,
AO, AT, AU, AZ, BA, BB, BG, BH, BN, BR, BW, BY,
BZ, CA, CH, CL, CN, CO, CR, CU, CZ, DE, DK, DM,
DO, DZ, EC, EE, EG, ES, FI, GB, GD, GE, GH, GM, GT,
HN, HR, HU, ID, IL, IN, IS, JP, KE, KG, KN, KP, KZ,
LA, LC, LK, LR, LS, LT, LU, LY, MA, MD, ME, MG,
MK, MN, MW, MX, MY, MZ, NA, NG, NI, NO, NZ, OM,
PA, PE, PG, PH, PL, PT, QA, RO, RS, RU, RW, SC, SD,
SE, SG, SK, SL, SM, ST, SV, SY, TH, TJ, TM, TN, TR,
TT, TZ, UA, UG, US, UZ, VC, VN, ZA, ZM, ZW.
- (84) Designated States (unless otherwise indicated, for every
kind of regional protection available): ARIPO (BW, GH,
GM, KE, LR, LS, MW, MZ, NA, RW, SD, SL, SZ, TZ,
UG, ZM, ZW), Eurasian (AM, AZ, BY, KG, KZ, RU, TJ,
TM), European (AL, AT, BE, BG, CH, CY, CZ, DE, DK,
EE, ES, FI, FR, GB, GR, HR, HU, IE, IS, IT, LT, LU, LV,
MC, MK, MT, NL, NO, PL, PT, RO, RS, SE, SI, SK, SM,
TR), OAPI (BF, BJ, CF, CG, CI, CM, GA, GN, GQ, GW,
KM, ML, MR, NE, SN, TD, TG).
- Published:
— with international search report (Art. 21(3))

(54) Title: METHOD OF DISPLAYING VIRTUAL RULER ON SEPARATE IMAGE OR MEDICAL IMAGE OF OBJECT, MEDICAL IMAGE OBTAINING APPARATUS, AND METHOD AND APPARATUS FOR DISPLAYING SEPARATE IMAGE OR MEDICAL IMAGE WITH VIRTUAL RULER



(57) Abstract: A method of displaying a virtual ruler on separate images of an object includes: dividing the object into imaging areas in a predetermined direction and obtaining the separate images corresponding to the imaging areas; obtaining a first distance value for each respective separate image, as a distance from a reference point to a first side of the respective separate image, and a second distance value for each respective separate image, as a distance from the reference point to a second side of the respective separate image, the first side being opposite to the second side along the predetermined direction; and displaying the virtual ruler, which indicates distance values between the first distance value and the second distance value of each respective separate image, on each of the respective separate images.

WO 2014/038786 A1

Description

Title of Invention: METHOD OF DISPLAYING VIRTUAL RULER ON SEPARATE IMAGE OR MEDICAL IMAGE OF OBJECT, MEDICAL IMAGE OBTAINING APPARATUS, AND METHOD AND APPARATUS FOR DISPLAYING SEPARATE IMAGE OR MEDICAL IMAGE WITH VIRTUAL RULER

Technical Field

- [1] Apparatuses and methods consistent with exemplary embodiments relate to displaying a virtual ruler on a separate image or medical image of an object.

Background Art

- [2] A magnetic resonance imaging (MRI) apparatus, a computed tomography (CT) apparatus, and an X-ray apparatus are used to obtain medical images of a body of a patient. Due to the resolution of images or the sizes of the above-mentioned apparatuses, an image of the entire body of the patient cannot be imaged at once and may be obtained as a composite image by imaging each of portions of the body and then composing captured images.
- [3] The medical image obtaining apparatus may provide a function of automatically composing separate images of a body, but the composition of the separate images may be performed inaccurately. For better accuracy, a method of indicating a ruler in each of separate images has been proposed, to allow a user to manually compose separate images. However, there is a need for a method of efficiently, accurately, and conveniently indicating a ruler in each of separate images to allow a user to more accurately and precisely compose the separate images into a single image.

Disclosure of Invention

Solution to Problem

- [4] One or more exemplary embodiments provide a method of displaying a virtual ruler on a separate image or medical image of an object, by displaying the virtual ruler on each of the plurality of separate images without imaging the object together with a lead ruler when capturing the plurality of separate images of the object to generate a composite image of the object.

Advantageous Effects of Invention

- [5] According to an aspect of an exemplary embodiment, when capturing the plurality of separate images of the object to generate a composite image of the object, there is no need to image the object together with a lead ruler by displaying a virtual ruler on each of the plurality of separate images.

Brief Description of Drawings

- [6] The above and/or other aspects will become more apparent by describing certain exemplary embodiments, with reference to the accompanying drawings, in which:
- [7] FIG. 1 is a diagram for explaining a method of capturing separate images of an object to generate a composite image of the object;
- [8] FIG. 2 is a block diagram of a medical image obtaining apparatus according to an exemplary embodiment;
- [9] FIG. 3 is a diagram illustrating a plurality of imaging areas of an object;
- [10] FIG. 4 is a diagram illustrating a first distance and second distance of the image obtainer, in the medical image obtaining apparatus according to an exemplary embodiment;
- [11] FIG. 5 is a diagram for explaining another method of measuring a first distance and a second distance of the separate image;
- [12] FIG. 6 is a diagram illustrating a display of the medical image obtaining apparatus, according to an exemplary embodiment;
- [13] FIG. 7 is a diagram illustrating a display that displays a composite image obtained by combining the separate images;
- [14] FIG. 8 is a diagram illustrating a display that displays only separate images without displaying virtual rulers;
- [15] FIG. 9 is a diagram illustrating a display that displays a separate image and a virtual ruler, which are magnified;
- [16] FIG. 10 is a diagram illustrating a display that displays a separate image and a virtual ruler, which are de-magnified;
- [17] FIG. 11 is a diagram illustrating a display that displays a separate image and a virtual ruler, which are greatly magnified compared to a predetermined area;
- [18] FIG. 12a is a diagram illustrating a display that displays a separate image which is moved horizontally;
- [19] FIG. 12b is a diagram illustrating a display that displays a separate image which is moved vertically;
- [20] FIG. 13 is a flowchart illustrating a method of displaying a virtual ruler on the separate images of an object, according to an exemplary embodiment;
- [21] FIG. 14 is a flowchart illustrating a method of displaying a virtual ruler on the separate images of an object, according to an exemplary embodiment;
- [22] FIG. 15 is a flowchart illustrating a method of displaying a virtual ruler on the separate images of an object, according to an exemplary embodiment;
- [23] FIG. 16 is a block diagram of a display device according to an exemplary embodiment; and

[24] FIG. 17 is a flowchart illustrating a method of displaying a virtual ruler on the separate images of an object, according to an exemplary embodiment.

Best Mode for Carrying out the Invention

[25] According to an aspect of an exemplary embodiment, there is provided a method of displaying a virtual ruler on each of a plurality of separate images of an object to generate a composite image, the method including: dividing the object into a plurality of imaging areas in a predetermined direction and obtaining a plurality of separate images corresponding to the plurality of imaging areas; obtaining a first distance of a separate image, which is a distance from a predetermined reference point to a first side of each of the plurality of separate images, and a second distance of the separate image, which is a distance from the predetermined reference point to a second side of each of the plurality of separate images; and displaying a virtual ruler, which indicates distance values between the obtained first distance of the separate image and the obtained second distance of the separate image, on each of the plurality of separate images.

[26] The method of displaying a virtual ruler on each of a plurality of separate images of an object may be performed by an X-ray apparatus.

[27] The obtaining of the plurality of separate images of the object may include obtaining the plurality of separate images at locations corresponding to the plurality of imaging areas by using an image obtainer that obtains X-ray images by using X-rays penetrating the object.

[28] The obtaining of the first distance of the separate image and the second distance of the separate image may include obtaining, at locations corresponding to the plurality of imaging areas, a distance from the predetermined reference point to a first side of the image obtainer as the first distance of the separate image and a distance from the predetermined reference point to a second side of the image obtainer as the second distance of the separate image.

[29] The displaying of the virtual ruler on each of the plurality of separate images may include: obtaining an actual distance of each pixel of the separate image by using a difference value between the first distance of the separate image and the second distance of the separate image and the number of pixels in a predetermined direction of the separate image; and displaying the virtual ruler on each of the plurality of separate images by using the first distance and the actual distance of each pixel, or the second distance and the actual distance of each pixel.

[30] The displaying of the virtual ruler on each of the plurality of separate images may include: dividing the separate image into a plurality of areas in the predetermined direction; and displaying the virtual ruler on each of the plurality of separate images by

using the first distance and a value, which is obtained by dividing a difference value between the first distance of the separate image and the second distance of the separate image by the number of the plurality of areas, or the second distance and the value, which is obtained by dividing a difference value between the first distance of the separate image and the second distance of the separate image by the number of the plurality of areas.

- [31] The predetermined direction may include a vertical direction of the object, the first side of each of the obtained plurality of separate images may include an upper side of each of the obtained plurality of separate images, and the second side of each of the obtained plurality of separate images may include a lower side of each of the obtained plurality of separate images.
- [32] The method of displaying a virtual ruler on each of a plurality of separate images of an object may further include displaying the plurality of separate images on each of which the virtual ruler is displayed; and when at least one separate image of the displayed plurality of separate images is moved horizontally, not moving at least one virtual ruler displayed on the at least one separate image or simultaneously moving a plurality of virtual rulers displayed on the plurality of separate images horizontally according to the horizontal movement.
- [33] The method of displaying a virtual ruler on each of a plurality of separate images of an object may further include displaying the plurality of separate images on each of which the virtual ruler is displayed; and when at least one separate image of the displayed plurality of separate images is moved vertically, moving only at least one virtual ruler displayed on the at least one separate image vertically according to the vertical movement.
- [34] According to another aspect of an exemplary embodiment, there is provided a medical image obtaining apparatus for displaying a virtual ruler on each of a plurality of separate images of an object to generate a composite image, the apparatus including: an image obtainer for dividing the object into a plurality of imaging areas in a predetermined direction and obtaining a plurality of separate images corresponding to the plurality of imaging areas; a location obtainer for obtaining a first distance of a separate image, which is a distance from a predetermined reference point to a first side of each of the plurality of separate images, and a second distance of the separate image, which is a distance from the predetermined reference point to a second side of each of the plurality of separate images; and a controller for displaying a virtual ruler, which indicates distance values between the obtained first distance of the separate image and the obtained second distance of the separate image, on each of the plurality of separate images.
- [35] The image obtainer may obtain the plurality of separate images at locations corre-

sponding to the plurality of imaging areas by using X-rays penetrating the object.

- [36] The location obtainer may obtain, at locations corresponding to the plurality of imaging areas, a distance from the predetermined reference point to a first side of the image obtainer as the first distance of the separate image and a distance from the predetermined reference point to a second side of the image obtainer as the second distance of the separate image.
- [37] The controller may obtain an actual distance of each pixel of the separate image by using a difference value between the first distance of the separate image and the second distance of the separate image and the number of pixels in a predetermined direction of the separate image; and may display the virtual ruler on each of the plurality of separate images by using the first distance and the actual distance of each pixel, or the second distance and the actual distance of each pixel.
- [38] The controller may divide the separate image into a plurality of areas in the predetermined direction; and may display the virtual ruler on each of the plurality of separate images by using the first distance and a value, which is obtained by dividing a difference value between the first distance of the separate image and the second distance of the separate image by the number of the plurality of areas, or the second distance and the value, which is obtained by dividing a difference value between the first distance of the separate image and the second distance of the separate image by the number of the plurality of areas.
- [39] The predetermined direction may include a vertical direction of the object, the first side of each of the obtained plurality of separate images may include an upper side of each of the obtained plurality of separate images, and the second side of each of the obtained plurality of separate images may include a lower side of each of the obtained plurality of separate images.
- [40] The medical image obtaining apparatus may further include a display for displaying the plurality of separate images on each of which the virtual ruler is displayed, wherein when at least one separate image of the displayed plurality of separate images is moved horizontally, the display may not move at least one virtual ruler displayed on the at least one separate image or may simultaneously move a plurality of virtual rulers displayed on the plurality of separate images horizontally according to the horizontal movement.
- [41] The medical image obtaining apparatus may further include a display for displaying the plurality of separate images on each of which the virtual ruler is displayed, wherein when at least one separate image of the displayed plurality of separate images is moved vertically, the display may move only at least one virtual ruler displayed on the at least one separate image vertically according to the vertical movement.
- [42] According to another aspect of an exemplary embodiment, there is provided a

method of displaying a virtual ruler on each of a plurality of separate images of an object by using a medical image obtaining apparatus to generate a composite image of the object, the method including: dividing the object into a plurality of imaging areas in a predetermined direction by using an image obtainer of the medical image obtaining apparatus and obtaining a plurality of separate images corresponding to the plurality of imaging areas; and displaying a virtual ruler on each of the plurality of separate images based on information about a location of the image obtainer.

- [43] The obtaining of the plurality of separate images of the object may include obtaining the plurality of separate images corresponding to the plurality of imaging areas at locations corresponding to the plurality of imaging areas by using the image obtainer.
- [44] The displaying of the virtual ruler on each of the plurality of separate images may include: obtaining a first distance of the image obtainer, which is a distance from a predetermined reference point to a first side of the image obtainer, and a second distance of the image obtainer, which is a distance from the predetermined reference point to a second side of the image obtainer; and displaying a virtual ruler, which indicates distance values between the obtained first distance of the image obtainer and the obtained second distance of the image obtainer, on each of the plurality of separate images.
- [45] The displaying of the virtual ruler on each of the plurality of separate images may include: obtaining a first distance of a separate image, which is a distance from a predetermined reference point to a first side of each of the plurality of separate images, and a second distance of the separate image, which is a distance from the predetermined reference point to a second side of each of the plurality of separate images, by using information about a location of an X-ray emitter for emitting X-rays to the object, information about a location of the image obtainer, and a distance between the object and the image obtainer; and displaying a virtual ruler, which indicates distance values between the obtained first distance of the separate image and the obtained second distance of the separate image, on each of the plurality of separate images.
- [46] The obtaining of the first distance of the separate image and the second distance of the separate image may include obtaining the first distance of the separate image and the second distance of the separate image by using a distance x_1 between the X-ray emitter and the image obtainer, a distance x_2 between the object and the image obtainer, the first distance y_1 of the image obtainer, second distance y_1' of the image obtainer, and a distance y_2 from the predetermined reference point to the X-ray emitter.
- [47] The first distance of the separate image may be obtained by using an Equation $y_2 - \{(y_2 - y_1) \times (x_1 - x_2) / x_1\}$, and the second distance of the separate image may be obtained by using an Equation $y_2 + \{(y_1' - y_2) \times (x_1 - x_2) / x_1\}$.

- [48] The displaying of the virtual ruler on each of the plurality of separate images may include automatically composing the plurality of separate images in consideration of distance values of the virtual ruler displayed on each of the plurality of separate images.
- [49] The automatic composing of the plurality of separate images may include overlapping a first separate image of the plurality of separate images with a second separate image of the plurality of the separate images at points with the same distance value from among points corresponding to distance values of a first virtual ruler displayed on the first separate image and points corresponding to distance values of a second virtual ruler displayed on the second separate image.
- [50] The displaying of the virtual ruler on each of the plurality of separate images may further include displaying the plurality of separate images, on each of which the virtual ruler is displayed, on a predetermined area of a display of the medical image obtaining apparatus.
- [51] The displaying of the plurality of separate images may include displaying only the plurality of separate images without the virtual ruler displayed on each of the plurality of separate images on the predetermined area, based on an off input of a user.
- [52] The displaying of the plurality of separate images may include magnifying the plurality of separate images and the virtual ruler displayed on each of the plurality of separate images, based on a zoom-in input of a user.
- [53] The magnifying of the plurality of separate images and the virtual ruler may include moving a position of a first virtual ruler displayed on a first separate image of the plurality of separate images so that the first virtual ruler is not outside the predetermined area when the first separate image and the first virtual ruler displayed on the first separate image are magnified.
- [54] The displaying of the plurality of separate images may include de-magnifying the plurality of separate images and the virtual ruler displayed on each of the plurality of separate images, based on a zoom-out input of a user.
- [55] The displaying of the plurality of separate images may include: when at least one separate image of the displayed plurality of separate images is moved horizontally by a user's input, not moving at least one virtual ruler displayed on the at least one separate image or simultaneously moving a plurality of virtual rulers displayed on the plurality of separate images horizontally according to the horizontal movement.
- [56] The displaying of the plurality of separate images may include: when at least one separate image of the displayed plurality of separate images is moved vertically by a user's input, moving only at least one virtual ruler displayed on the at least one separate image vertically according to the vertical movement.
- [57] According to another aspect of an exemplary embodiment, there is provided a

method of displaying a virtual ruler on a medical image of an object by using a medical image obtaining apparatus, the method including: obtaining a medical image corresponding to a imaging area of the object by using an image obtainer of the medical image obtaining apparatus; and displaying a virtual ruler on the medical image based on information about a location of the image obtainer.

[58] The obtaining of the medical image may include obtaining the medical image corresponding to the imaging area at a location corresponding to the imaging area of the object by using the image obtainer.

[59] The displaying of the virtual ruler on the medical image may include: obtaining a first distance of the image obtainer, which is a distance from a predetermined reference point to a first side of the image obtainer, and a second distance of the image obtainer, which is a distance from the predetermined reference point to a second side of the image obtainer; and displaying a virtual ruler, which indicates distance values between the obtained first distance of the image obtainer and the obtained second distance of the image obtainer, on the medical image.

[60] The displaying of the virtual ruler on the medical image may include: obtaining a first distance of a separate image, which is a distance from a predetermined reference point to a first side of the medical image, and a second distance of the separate image, which is a distance from the predetermined reference point to a second side of the medical image, by using information about a location of an X-ray emitter for emitting X-rays to the object, information about a location of the image obtainer, and a distance between the object and the image obtainer; and displaying a virtual ruler, which indicates distance values between the obtained first distance of the separate image and the obtained second distance of the separate image, on the medical image.

[61] According to another aspect of an exemplary embodiment, there is provided a method of displaying a plurality of separate images of an object, the method including: displaying a plurality of separate images, on each of which a virtual ruler is displayed, on a predetermined area of a display; and displaying only the plurality of separate images without the virtual ruler displayed on each of the plurality of separate images on the predetermined area, based on an off input of a user.

[62] The method of displaying a plurality of separate images of an object may further include magnifying the plurality of separate images and the virtual ruler displayed on each of the plurality of separate images, based on a zoom-in input of a user.

[63] The magnifying of the plurality of separate images and the virtual ruler may include moving a position of a first virtual ruler displayed on a first separate image of the plurality of separate images so that the first virtual ruler is not outside the predetermined area when the first separate image and the first virtual ruler displayed on the first separate image are magnified.

- [64] The method of displaying a plurality of separate images of an object may further include de-magnifying the plurality of separate images and the virtual ruler displayed on each of the plurality of separate images, based on a zoom-out input of a user.
- [65] The method of displaying a plurality of separate images of an object may further include: when at least one separate image of the displayed plurality of separate images is moved horizontally by a user's input, not moving at least one virtual ruler displayed on the at least one separate image or simultaneously moving a plurality of virtual rulers displayed on the plurality of separate images horizontally according to the horizontal movement.
- [66] The method of displaying a plurality of separate images of an object may further include: when at least one separate image of the displayed plurality of separate images is moved vertically by a user's input, moving only at least one virtual ruler displayed on the at least one separate image vertically according to the vertical movement.
- [67] According to another aspect of an exemplary embodiment, there is provided a computer-readable recording medium having recorded thereon a program for executing the method of displaying a virtual ruler on each of a plurality of separate images of an object or the method of displaying a virtual ruler on a medical image of an object.
- [68] According to another aspect of an exemplary embodiment, there is provided a computer-readable recording medium having recorded thereon a program for executing the method of displaying a plurality of separate images of an object.
- [69] According to another aspect of an exemplary embodiment, there is provided a medical image obtaining apparatus for displaying a virtual ruler on each of a plurality of separate images of an object to generate a composite image, the apparatus including: an image obtainer for dividing the object into a plurality of imaging areas in a predetermined direction and obtaining a plurality of separate images for the object; a location obtainer for obtaining information about a location of the image obtainer; and a controller for displaying a virtual ruler on each of the plurality of separate images based on the information about the location of the image obtainer.
- [70] According to another aspect of an exemplary embodiment, there is provided a medical image obtaining apparatus including: an image obtainer for obtaining a medical image corresponding to an imaging area of an object; a location obtainer for obtaining information about a location of the image obtainer; and a controller for displaying a virtual ruler on the medical image based on the information about the location of the image obtainer.
- [71] According to another aspect of an exemplary embodiment, there is provided a display device including: a display for displaying a plurality of separate images, on each of which a virtual ruler is displayed, on a predetermined area; and a user input unit for receiving a predetermined input from a user, wherein the display displays only

the plurality of separate images without the virtual ruler displayed on each of the plurality of separate images on the predetermined area, based on an off input of a user, which is received through the user input unit.

Mode for the Invention

- [72] This application claims the priority from Korean Patent Application No. 10-2012-0099547, filed on September 7, 2012, and Korean Patent Application No. 10-2013-0026812, filed on March 13, 2013, in the Korean Intellectual Property Office, the disclosures of which are incorporated herein in their entireties by reference.
- [73] Certain exemplary embodiments are described below with reference to the accompanying drawings.
- [74] In the following description, same drawing reference numerals are used for the same elements, even in different drawings. The matters defined in the description, such as detailed construction and elements, are provided to assist in a comprehensive understanding of exemplary embodiments. However, exemplary embodiments can be practiced without those specifically defined matters. Also, well-known functions or constructions are not described in detail since they would obscure the application with unnecessary detail.
- [75] The term unit in exemplary embodiments means a software component or hardware components such as a field-programmable gate array (FPGA) or an application-specific integrated circuit (ASIC), and performs a specific function. However, the unit is not limited to software or hardware. The unit may be an addressable storage medium, or may be formed to operate one or more processors. Thus, for example, the unit may refer to components such as software components, object-oriented software components, class components, and task components, and may include processes, functions, attributes, procedures, subroutines, segments of program code, drivers, firmware, micro codes, circuits, data, a database, data structures, tables, arrays, or variables. A function provided by the components and units may be associated with the smaller number of components and units, or may be divided into additional components and units.
- [76] In exemplary embodiments, an object denotes a target object or a part of the target object for medical image capture, and may include a human, an animal, or a portion of a human or animal.
- [77] FIG. 1 is a diagram for explaining a method of capturing separate images of an object to generate a composite image of the object. FIG. 1 illustrates a method of generating a composite image by using an X-ray apparatus.
- [78] When an X-ray tube 20 emits X-rays 22 toward an object 10, an image obtainer 30 obtains an image of the object 10 by sensing X-rays penetrating the object 10. The

image obtainer 30 may include an X-ray detector of the X-ray apparatus.

- [79] In order to generate a composite image of the object 10, images of portions of the object 10 are obtained while rotating or moving the X-ray tube 20 and moving the image obtainer 30, for example, upward and downward since the size of the image obtainer 30 is generally smaller than that of the object 10. Then, a composite image of the object 10 is obtained by composing the images of the portions.
- [80] When capturing separate images of the object 10 according to a related art composite image generating method, a lead ruler 40 is placed beside the object 10 to indicate the location of each of separate images on each of the separate images, and the object 10 and the lead ruler 40 are imaged together. However, the placement of the lead ruler 40 beside the object results in wasteful expense and inconvenience in terms of utilization of an X-ray imaging space.
- [81] An apparatus and method of displaying a virtual ruler on each of a plurality of separate images of an object, according to exemplary embodiments, may accurately display information about the location of each of a plurality of separate images on each of the plurality of separate images without having to place the lead ruler 40 beside the object during imaging.
- [82] FIG. 2 is a block diagram of a medical image obtaining apparatus 200 according to an exemplary embodiment.
- [83] Referring to FIG. 2, the medical image obtaining apparatus 200 may include an image obtainer 210, a location obtainer 220, and a controller 230.
- [84] The medical image obtaining apparatus 200 may be included in an X-ray apparatus, and the location obtainer 220 or the controller 230 may be configured by using a microprocessor.
- [85] The image obtainer 210 divides the object into a plurality of imaging areas in a predetermined direction, and obtains a plurality of separate images of the object corresponding to the respective imaging areas. The image obtainer 210 may divide the object in the vertical direction 24 of the object, which may coincide with a lengthwise dimension of the object and/or imaging direction.
- [86] FIG. 3 is a diagram illustrating a plurality of imaging areas 132 and 134 of an object. The image obtainer 210 may move in the vertical direction 24 and may divide the object 10 into a plurality of imaging areas in the vertical direction 24. In detail, the image obtainer 210 may divide the object 10 into a plurality of imaging areas 132 and 134 in the vertical direction 24, may move to the plurality of imaging areas 132 and 134, and may obtain separate images corresponding to the plurality of imaging areas of the object 10 by sensing X-rays 22 penetrating the object 10. The separate images may partially overlap each other. Although FIG. 3 illustrates only two imaging areas 132 and 134, the object 10 may be divided into three or more imaging areas.

- [87] The location obtainer 220 may obtain a first distance from a predetermined reference point to a first side of each of the separate images and a second distance from the predetermined reference point to a second side of each of the separate images. The predetermined reference point may be located in an upper side of the image obtainer 210 when the image obtainer 210 is located at the greatest point with respect to a freedom of movement in the vertical direction 24.
- [88] The first side may include a side surface or a side edge of a separate image, and the second side may include the other side surface or the other side edge of the same separate image. The first side and the second side may be disposed opposite to each other with respect to the separate image.
- [89] The controller 230 may display a virtual ruler, which indicates distance values between the first distance and the second distance, on each of the plurality of separate images.
- [90] For example, when a first distance of a first separate image of the plurality of separate images is measured to be 10 cm and a second distance of the first separate image is measured to be 30 cm, a virtual ruler from 10 cm to 30 cm is displayed on the first separate image. A user may accurately compose the plurality of separate images by using virtual rulers displayed on the plurality of separate images.
- [91] As an example the controller 230 may obtain an actual distance of each pixel of a separate image by using a difference value between first distance and the second distance and the number of pixels in a predetermined direction of the separate image. For example, when the first distance of the first separate image is 10 cm, the second distance is 30 cm, and the total number of pixels in a predetermined direction is 100, an actual distance of each pixel is 2 mm $((300 \text{ mm} - 100 \text{ mm})/100)$.
- [92] The controller 230 may determine a virtual ruler corresponding to distance values between the first distance and the second distance on each of the plurality of separate images by using the first distance and the actual distance of each pixel, or the second distance and the actual distance of each pixel. For example, when the first distance of the first separate image is 10 cm, the second distance is 30 cm, and the number of pixels in a predetermined direction is 100, a distance to a pixel which is located after a tenth pixel from the first side is 120 mm $(100 \text{ mm} + 10 \times 2 \text{ mm})$ with respect to the predetermined reference point R. The controller 230 may determine a distance value of each pixel of a separate image, and/or a distance value corresponding to a predetermined number of pixels of the separate image. Based on the above-described example, a length of ten pixels is 20 mm.
- [93] As another example, the controller 230 may divide each separate image into a plurality of areas in a predetermined direction, and may determine distance values corresponding to distances between dividing points, at which the plurality of areas are

divided, by using the first distance and a value which is obtained by dividing a difference value between the first distance and the second distance by the number of the plurality of areas, or the second distance and a value which is obtained by dividing a difference value between the first distance and the second distance by the number of the plurality of areas.

- [94] For example, if a separate image is divided into ten areas, and a difference value between first distance and the second distance is 20 cm, an actual distance of each area is 2 cm (20 cm/10). Accordingly, a distance to a dividing point at which a fifth area located at a fifth position from the first side and an sixth area located at a sixth position from the first side are divided, is 20 cm (10 cm + 5 x 2 cm), with respect to the predetermined reference point.
- [95] FIG. 4 is a diagram illustrating first distance y_1 of the image obtainer 210 and second distance y_1' of the image obtainer 210, in the medical image obtaining apparatus 200 illustrated in FIG. 2.
- [96] The location obtainer 220 may obtain information about the location of the image obtainer 210, and the controller 230 may display a virtual ruler on each of a plurality of separate images based on the information about the location of the image obtainer 210. In detail, the location obtainer 220 may obtain the first distance y_1 of the image obtainer 210 and the second distance y_1' of the image obtainer 210, and may set the first distance y_1 of the image obtainer 210 and the second distance y_1' of the image obtainer 210 as first distance of a separate image and the second distance of the separate image, respectively.
- [97] Referring to FIG. 4, the first distance y_1 is a distance from a predetermined reference point R to an upper side 212 of the image obtainer 210, and the second distance y_1' is a distance from the predetermined reference point R to a lower side 214 of the image obtainer 210. For example, the upper side includes an upper side edge or an upper side surface, and the lower side includes a lower side edge or a lower side surface. The X-ray apparatus may measure the first distance and the second distance of the image obtainer 210 to accurately determine which portion of the object is being imaged. When the image obtainer 210 is located at the greatest height, and the predetermined reference point R is set to be located in the upper side of the image obtainer 210, a distance from the predetermined reference point R to the upper side of the image obtainer 210 is zero.
- [98] FIG. 5 is a diagram for explaining another method of measuring first distance of a separate image and second distance of the separate image.
- [99] In order to take an X-ray of an object 10, the object 10 is spaced apart from the image obtainer 210 by a predetermined distance. Accordingly, as described above, the location obtainer 220 sets first distance of the image obtainer 210 and the second

distance of the image obtainer 210 as first distance of a separate image and the second distance of the separate image, respectively, an actual length of the object 10 or an actual length of an organ included in the object 10 may be measured with insufficient accuracy.

[100] To improve the accuracy, the location obtainer 220 may obtain the first distance of a separate image and the second distance of the separate image by using information about the location of an X-ray emitter 20 for emitting X-rays to the object 10, information about the location of the image obtainer 210, and a distance between the object 10 and the image obtainer 210.

[101] In detail, when a distance between the X-ray emitter 20 and the image obtainer 210 is x_1 , the distance between the object 10 and the image obtainer 210 is x_2 , first distance of the image obtainer 210 is y_1 , second distance of the image obtainer 210 is y_1' , and a distance from a predetermined reference point to the X-ray emitter 20 is y_2 , z_1 illustrated in FIG. 5 may be calculated by using Equation 1 and z_1' illustrated in FIG. 5 may be calculated by using Equation 2.

[102] $z_1 = (y_2 - y_1) \times (x_1 - x_2) / x_1$ (1)

[103] $z_1' = (y_1' - y_2) \times (x_1 - x_2) / x_1$ (2)

[104] A distance from z_1 to first side of a separate image, that is, first distance of the separate image may be calculated by using Equation 3, and a distance from z_1' to second side of a separate image, that is, second distance of the separate image may be calculated by using Equation 4.

[105] First distance of separate image = $y_2 - \{(y_2 - y_1) \times (x_1 - x_2) / x_1\}$ (3)

[106] Second distance of separate image = $y_2 + \{(y_1' - y_2) \times (x_1 - x_2) / x_1\}$ (4)

[107] The controller 230 may display a virtual ruler indicating distance values between first distance of a separate image and second distance of the separate image, which are calculated by using Equation 3 and Equation 4, on each of a plurality of separate images. Since the virtual ruler obtained by using Equation 3 and Equation 4 indicates an actual distance with respect to a predetermined reference point, a user may easily measure an actual length of an object of each separate image or an actual length of an organ included in the object.

[108] Although a case where a virtual ruler is displayed on a plurality of separate images of an object is described above, a virtual ruler may be displayed on a single medical image of an object. That is, a virtual ruler may be displayed on a medical image, such as an image of a lung or an image of a breast, rather than on separate images for generating a composite image of an object.

[109] In detail, the image obtainer 210 obtains a medical image corresponding to an imaging area of an object. The imaging area of an object may be set by a user, and may include a head area, a breast area, or an abdomen area.

- [110] The location obtainer 220 obtains information about the location of the image obtainer 210. The location obtainer 220 may obtain first distance of the image obtainer 210 and second distance of the image obtainer 210.
- [111] The controller 230 displays a virtual ruler on a medical image based on the information about the location of the image obtainer 210. In detail, the controller 230 may display a virtual ruler, which indicates distance values between the first distance of the image obtainer 210 and the second distance of the image obtainer 210, on a medical image. In addition, the controller 230 may also display a virtual ruler indicating distance values between first distance of a medical image and second distance of the medical image, which are obtained by using Equation 3 and Equation 4, on the medical image.
- [112] FIG. 6 is a diagram illustrating a display 240 of the medical image obtaining apparatus 200, according to an exemplary embodiment. The display 240 may be a component included in the apparatus 200 illustrated in FIG. 2.
- [113] The display 240 of the medical image obtaining apparatus 200 may display a plurality of separate images 250a, 250b, and 250c, on which virtual rulers 260a, 260b, and 260c respectively are shown, on a predetermined area 242 of the display 240.
- [114] The display 240 illustrated in FIG. 6 displays a first separate image 250a together with a first virtual ruler 260a, a second separate image 250b together with a second virtual ruler 260b, and a third separate image 250c together with a third virtual ruler 260c on the predetermined area 242. In addition, the display 240 displays a toolbar 270 for controlling the first separate image 250a, the second separate image 250b, and the third separate image 250c on an area 243 that is different from the predetermined area 242. The toolbar 270 is an interface provided for users, and a user may input a predetermined input to the toolbar 270 by using a user input unit.
- [115] The user input unit may include a mouse, a keyboard, a trackball, etc., but is not limited thereto. If the display 240 is a touch screen, the display 240 may be used as the user input unit.
- [116] FIG. 7 is a diagram illustrating the display 240 that displays a composite image obtained by combining or composing the first separate image 250a, the second separate image 250b, and the third separate image 250c.
- [117] A user may manually compose the first separate image 250a, the second separate image 250b, and the third separate image 250c with reference to distance values shown on the scales of the first through third virtual rulers 260a, 260b, and 260c that are displayed on the first through third separate images 250a, 250b, and 250c, respectively.
- [118] In addition, the medical image obtaining apparatus 200 according to the current exemplary embodiment may provide an automatic composition function to a user. The controller 230 may automatically compose the first separate image 250a, the second

separate image 250b, and the third separate image 250c based on distance values of the first through third virtual rulers 260a, 260b, and 260c displayed on the first through third separate images 250a, 250b, and 250c, respectively, when an automatic composition input 272 is received from a user.

- [119] The controller may compose the first separate image 250a and the second separate image 250b by overlapping the first separate image 250a and the second separate image 250b at two points with the same distance value from among points corresponding to distance values of the first virtual ruler 260a displayed on the first separate image 250a and points corresponding to distance values of the second virtual ruler 260b displayed on the second separate image 250b. For example, when each of scales of the first and second virtual rulers 260a and 260b displayed on the first and second separate images 250a and 250b, respectively, includes a point corresponding to a distance value of 20 cm, the controller 230 may overlap the first separate image 250a and the second separate image 250b at two points corresponding to the distance value of 20 cm on the first and second virtual rulers 260a and 260b.
- [120] FIG. 8 is a diagram illustrating the display 240 that displays only the first separate image 250a, the second separate image 250b, and the third separate image 250c without displaying the first through third virtual rulers 260a, 260b, and 260c.
- [121] In the related art, if a lead ruler and an object are imaged together to display an image of the lead ruler and the object, it is very difficult to delete the lead ruler from separate images. Thus, it may be difficult for a user to accurately identify the object when the lead ruler hides the object.
- [122] Since the virtual rulers 260a, 260b, and 260c according to an exemplary embodiment are not imaged together with an object, the virtual rulers 260a, 260b, and 260c may be easily eliminated from separate images. That is, when an off input 274 is received from a user, the controller 230 may delete the first through third virtual rulers 260a, 260b, and 260c displayed on the first through third separate images 250a, 250b, and 250c, respectively, and may display only the first through third separate images 250a, 250b, and 250c on the display 240. When an input which deactivates the off input or an on input is received from a user, the controller 230 may display the first through third virtual rulers 260a, 260b, and 260c again on the first through third separate images 250a, 250b, and 250c, respectively.
- [123] FIG. 9 is a diagram illustrating the display 240 that displays the first separate image 250a and the first virtual ruler 260a, which are magnified by the controller 230, and FIG. 10 is a diagram illustrating the display 240 that displays the first separate image 250a and the first virtual ruler 260a, which are de-magnified by the controller 230.
- [124] As illustrated in FIG. 9, the controller 230 may magnify the first separate image 250a and the first virtual ruler 260a displayed on the first separate image 250a by a prede-

terminated magnifying power when a zoom-in input 276 for the first separate image 250a is received from a user.

[125] As illustrated in FIG. 10, the controller 230 may de-magnify the first separate image 250a and the first virtual ruler 260a displayed on the first separate image 250a by a predetermined magnifying power when a zoom-out input 278 for the first separate image 250a is received from a user.

[126] FIG. 11 is a diagram illustrating the display 240 that displays the first separate image 250a and the first virtual ruler 260a, which are greatly magnified compared to a predetermined area.

[127] In the related art in which a lead ruler and an object are imaged together, when a user greatly magnifies a separate image compared to a predetermined area of the display 240, a lead ruler displayed on the separate image may be out of the predetermined area of the display 240 and thus the user cannot check the lead ruler.

[128] Accordingly, when the first separate image 250a and the first virtual ruler 260a are magnified according to the zoom-in input 276 of a user, the controller 230 may move a position of the first virtual ruler 260a so that the first virtual ruler 260a is not out of the predetermined area of the display 240.

[129] In FIG. 11, the first virtual ruler 260a displayed on an outside area 277 of the first separate image 250a illustrated in FIG. 6 moves to an inside area 279 of the first separate image 250a with the magnification of the first virtual ruler 260a, and thus is displayed in a predetermined area 242 of the display 240.

[130] FIG. 12a is a diagram illustrating the display 240 that displays the first separate image 250a which is moved horizontally, and FIG. 12b is a diagram illustrating the display 240 that displays the first separate image 250a which is moved vertically.

[131] In order to allow a user to easily compose the first through third separate images 250a, 250b, and 250c, when the user moves the first through third separate images 250a, 250b, and 250c horizontally or vertically, the medical image obtaining apparatus 200 according to an exemplary embodiment may adjust the first through third virtual rulers 260a, 260b, 260c displayed on the first through third separate images 250a, 250b, and 250c, respectively, according to the horizontal movement or the vertical movement of the first through third separate images 250a, 250b, and 250c.

[132] Referring to FIG. 12a, when the controller 230 moves the first separate image 250a horizontally, the controller 230 may make the first virtual ruler 260a maintain the same axis as the other virtual rulers, i.e., the second and third virtual rulers 260b and 260c, without moving the first virtual ruler 260a displayed on the first separate image 250a. If the first virtual ruler 260a moves horizontally according to the horizontal movement of the first separate image 250a, the first virtual ruler 260a is not located on the same axis as the other virtual ruler, i.e., the second and third virtual rulers 260b and 260c,

thereby causing inconvenience to a user when the user reads the scale of the first ruler 260a. Alternatively, the controller 230 may simultaneously move all the virtual rulers 260a, 260b, and 260c displayed on all of the separate images 250a, 250b, and 250c horizontally according to the horizontal movement of the first separate image 250a so that the virtual rulers 142a, 142b, and 142c may maintain the same axis.

- [133] Referring to FIG. 12b, when the controller 230 moves the first separate image 250a vertically, the controller 230 may move the first virtual ruler 260a displayed on the first separate image 250a vertically according to the vertical movement of the first separate image 250a because the scale of the first virtual ruler 260a displayed on the first separate image 250a varies if the first virtual ruler 260a does not move vertically according to the vertical movement of the first separate image 250a.
- [134] FIG. 13 is a flowchart illustrating a method of displaying a virtual ruler on each of a plurality of separate images of an object, according to an exemplary embodiment.
- [135] Referring to FIG. 13, the method of displaying a virtual ruler on each of a plurality of separate images of an object includes operations that are sequentially processed in the medical image obtaining apparatus 200 illustrated in FIG. 2. Accordingly, although not repeated below, the above description of the medical image obtaining apparatus 200 may apply to the method of FIG. 13.
- [136] In operation S1310, the medical image obtaining apparatus 200 divides an object into a plurality of imaging areas in a predetermined direction. The medical image obtaining apparatus 200 may include an X-ray image obtaining apparatus. The predetermined direction may include a vertical direction of the object.
- [137] In operation S1320, the medical image obtaining apparatus 200 obtains a plurality of separate images corresponding to the plurality of imaging areas. In detail, the image obtainer 210 of the medical image obtaining apparatus 200 may obtain a plurality of separate images corresponding to the plurality of imaging areas at locations corresponding to the plurality of imaging areas.
- [138] In operation S1330, the medical image obtaining apparatus 200 obtains a first distance from a predetermined reference point to a first side of each of the plurality of separate images and a second distance from the predetermined reference point to a second side of each of the plurality of separate images.
- [139] In operation S1340, the medical image obtaining apparatus 200 displays a virtual ruler, which indicates distance values between the obtained first distance of the separate image and the obtained second distance of the separate image, on each of the plurality of separate images.
- [140] FIG. 14 is a flowchart illustrating a method of displaying a virtual ruler on each of a plurality of separate images of an object, according to an exemplary embodiment.
- [141] In operation S1410, the image obtainer 210 of the medical image obtaining apparatus

- 200 divides an object into a plurality of imaging areas in a predetermined direction.
- [142] In operation S1420, the image obtainer 210 obtains a plurality of separate images corresponding to the plurality of imaging areas.
- [143] In operation S1430, the medical image obtaining apparatus 200 obtains information about the location of the image obtainer 210.
- [144] In operation S1440, the medical image obtaining apparatus 200 displays a virtual ruler on each of the plurality of separate images based on the information about the location of the image obtainer 210. In detail, the medical image obtaining apparatus 200 may obtain first distance of the image obtainer 210 and second distance of the image obtainer 210, and may also display a virtual ruler, which indicates distance values between the first distance of the image obtainer 210 and the second distance of the image obtainer 210, on each of the plurality of separate images.
- [145] Alternatively, the medical image obtaining apparatus 200 may obtain first distance of each of the plurality of separate images and second distance of each of the plurality of separate images based on the information about the location of the image obtainer 210, and may display a virtual ruler, which indicates distance values between the first distance of each of the plurality of separate images and the second distance of each of the plurality of separate images, on each of the plurality of separate images.
- [146] FIG. 15 is a flowchart illustrating a method of displaying a virtual ruler on each of a plurality of separate images of an object, according to an exemplary embodiment.
- [147] In operation S1510, the image obtainer 210 of the medical image obtaining apparatus 200 obtains a medical image corresponding to an imaging area of an object. The imaging area of the object may be set by a user.
- [148] In operation S1520, the medical image obtaining apparatus 200 obtains information about the location of the image obtainer 210.
- [149] In operation S1530, the medical image obtaining apparatus 200 displays a virtual ruler on the medical image based on the information about the location of the image obtainer 210. In detail, the medical image obtaining apparatus 200 may obtain first distance of the image obtainer 210 and second distance of the image obtainer 210, and may display a virtual ruler, which indicates distance values between the first distance of the image obtainer 210 and the second distance of the image obtainer 210, on the medical image.
- [150] Alternatively, the medical image obtaining apparatus 200 may obtain first distance of the medical image and second distance of the medical image based on the information about the location of the image obtainer 210, and may display a virtual ruler, which indicates distance values between the first distance of the medical image and the second distance of the medical image, on the medical image.
- [151] FIG. 16 is a block diagram of a display device 1600 according to an exemplary em-

bodiment.

- [152] Referring to FIG. 16, the display device 1600 may include a display 1610 and a user input unit 1620.
- [153] The display 1610 may show predetermined information to a user. The display 1610 may include a monitor.
- [154] The user input unit 1620 may receive a user's input, and may include a mouse, a keyboard, or a trackball. If the display 1610 is a touch screen, the display 1610 may be used as the user input unit 1620.
- [155] The user input unit 1620 may receive a predetermined input from a user.
- [156] The display 1610 may display a plurality of separate images, on each of which a virtual ruler is shown, on a predetermined area of the display 1610. In addition, the display 1610 may display only the plurality of separate images without virtual rulers shown on the plurality of separate images on the predetermined area, based on an off input of a user, which is received through the user input unit 1620.
- [157] If an input which deactivates the off input or an on input is received from a user, the display 1610 may display virtual rulers deleted from the plurality of separate images again.
- [158] In addition, if an automatic composition input, a magnification input, a de-magnification input, a horizontal movement input, or a vertical movement input is received from a user, the display 1610 may control a plurality of separate images, which are being displayed, to correspond to a corresponding input. Since a corresponding description is provided above with reference to FIGS. 6 through 12, a detailed description is not repeated.
- [159] Although a case in which the display device 1600 of FIG. 16 displays a plurality of separate images of an object is described above, the above description of FIGS. 6 and 8 through 11 may apply to a single medical image on which a virtual ruler is displayed. That is, a medical image, such as an image of a lung or an image of a breast, rather than separate images for generating a composite image of an object, may also be displayed by the display device 1600 of FIG. 16.
- [160] FIG. 17 is a flowchart illustrating a method of displaying a virtual ruler on each of a plurality of separate images of an object, according to an exemplary embodiment.
- [161] In operation S1710, the display device 1600 displays a plurality of separate images, on each of which a virtual ruler is shown, on a predetermined area of the display 1610.
- [162] In operation S1720, the display 1610 displays only the plurality of separate images without the virtual ruler shown on each of the plurality of separate images on the predetermined area, based on an off input of a user. The display 1610 may display the virtual ruler deleted from each of the plurality of separate images again according to an on input or an input which deactivates the off input that is received from a user.

- [163] The exemplary embodiments described above may be written as computer programs and may be implemented in general-use digital computers that execute programs using a computer-readable recording medium.
- [164] Examples of the computer-readable recording medium include magnetic storage media (e.g., ROM, floppy disks, hard disks, etc.) and optical recording media (e.g., CD-ROMs, and/or DVDs).
- [165] The foregoing exemplary embodiments and advantages are merely exemplary and are not to be construed as limiting. The present teaching can be readily applied to other types of apparatuses. Also, the description of the exemplary embodiments is intended to be illustrative, and not to limit the scope of the claims, and many alternatives, modifications, and variations will be apparent to those skilled in the art.

Claims

- [Claim 1] A method of displaying a virtual ruler on a plurality of separate images of an object, the method comprising:
dividing the object into a plurality of imaging areas in a predetermined direction by using an image obtainer and obtaining the plurality of separate images corresponding to the plurality of imaging areas; and displaying the virtual ruler on each of the plurality of separate images based on information about a location of the image obtainer.
- [Claim 2] The method of claim 1, wherein the obtaining the plurality of separate images comprises:
obtaining the plurality of separate images at locations corresponding to the plurality of imaging areas with the image obtainer.
- [Claim 3] The method of claim 1, wherein the displaying the virtual ruler comprises:
obtaining a first distance value for the image obtainer, as a distance from a reference point to a first side of the image obtainer, and a second distance value for the image obtainer, as a distance from the reference point to a second side of the image obtainer; and displaying the virtual ruler, which indicates distance values between the first distance value and the second distance value, on each of the separate images.
- [Claim 4] The method of claim 1, wherein the displaying the virtual ruler comprises:
obtaining a first distance value for respective separate images of the plurality of separate images, as a distance from a reference point to a first side of the respective separate image, and a second distance for respective separate images, as a distance from the reference point to a second side of the respective separate image, by using information about a location of an X-ray emitter, information about a location of the image obtainer, and a distance between the object and the image obtainer; and displaying the virtual ruler, which indicates distance values between the first distance value and the second distance value, on each respective separate image.
- [Claim 5] The method of claim 4, wherein the obtaining the first distance value and the second distance value comprises:
obtaining the first distance value and the second distance value by

- using a distance x_1 between the X-ray emitter and the image obtainer, a distance x_2 between the object and the image obtainer, a first distance y_1 of the image obtainer, a second distance y_1' of the image obtainer, and a distance y_2 from the reference point to the X-ray emitter.
- [Claim 6] The method of claim 5, wherein the first distance value is obtained by using an Equation $y_2 - \{(y_2 - y_1) \times (x_1 - x_2) / x_1\}$, and the second distance value is obtained by using an Equation $y_2 + \{(y_1' - y_2) \times (x_1 - x_2) / x_1\}$.
- [Claim 7] The method of claim 1, wherein the displaying the virtual ruler comprises:
automatically combining the plurality of separate images based on distance values indicated on the virtual ruler which is displayed on each of the plurality of separate images.
- [Claim 8] The method of claim 7, wherein the plurality of separate images comprises a first separate image and a second separate image, the displaying comprises displaying a first virtual ruler on the first separate image and displaying a second virtual ruler on the second separate image, and
the automatically combining comprises overlapping the first separate image with the second separate image between points with the same distance values indicated on the first virtual ruler and the second virtual ruler.
- [Claim 9] The method of claim 1, wherein the displaying the virtual ruler comprises:
displaying the plurality of separate images, on each of which the virtual ruler is displayed, on a predetermined area of a display of a medical image obtaining apparatus.
- [Claim 10] The method of claim 9, wherein the displaying the plurality of separate images comprises:
displaying only the plurality of separate images without the virtual ruler displayed on each of the plurality of separate images on the predetermined area, based on an off input of a user.
- [Claim 11] The method of claim 9, wherein the displaying the plurality of separate images comprises:
magnifying the plurality of separate images and the virtual ruler displayed on each of the plurality of separate images based on a zoom-in input of a user.
- [Claim 12] The method of claim 11, wherein the plurality of separate images

comprises a first separate image and a second separate image and the magnifying comprises:

moving a position of a first virtual ruler displayed on the first separate image so that the first virtual ruler is not outside the predetermined area when the first separate image and the first virtual ruler displayed on the first separate image are magnified.

[Claim 13]

The method of claim 9, wherein the displaying the plurality of separate images comprises:

when a respective separate image of the displayed plurality of separate images is moved horizontally based on a user input, not moving a virtual ruler displayed on the respective separate image or simultaneously moving a plurality of virtual rulers displayed on the plurality of separate images horizontally based on a horizontal movement.

[Claim 14]

The method of claim 9, wherein the displaying the plurality of separate images comprises:

when a respective separate image of the displayed plurality of separate images is moved vertically based on a user input, moving only a virtual ruler displayed on the respective separate image vertically based on a vertical movement.

[Claim 15]

A non-transitory computer-readable recording medium having recorded thereon a program which, when executed by a computer, causes the computer to execute the method of any one of claims 1 through 14.

[Fig. 1]

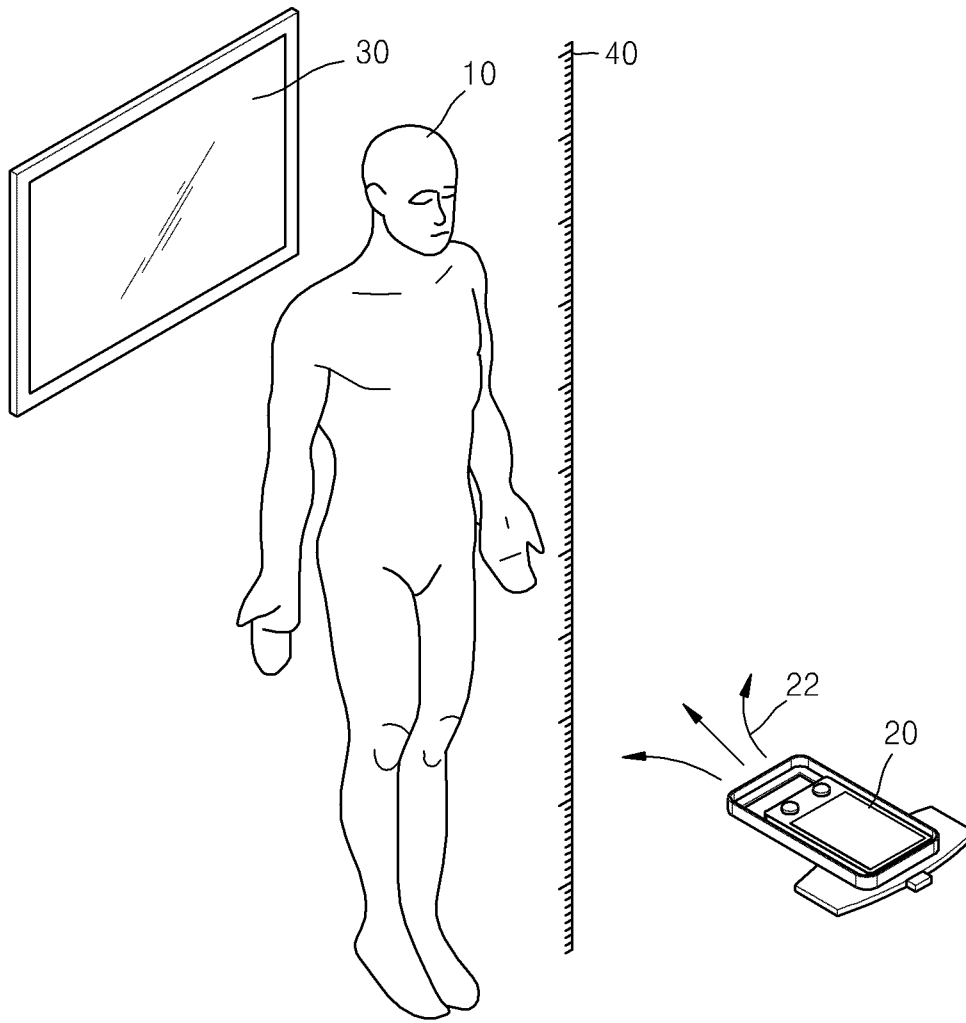

[Fig. 2]

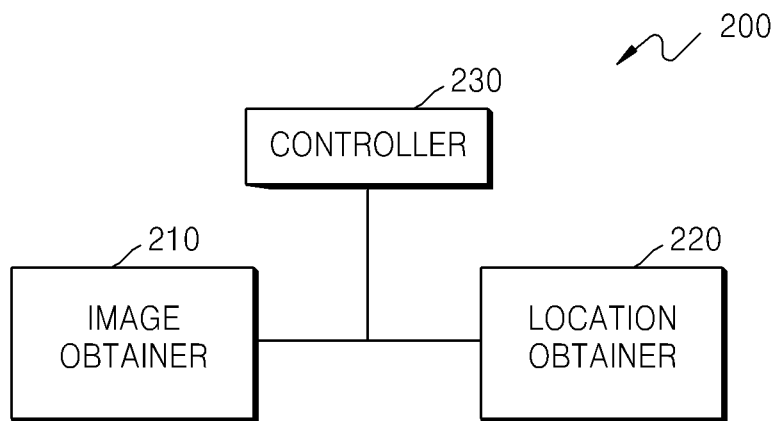

[Fig. 3]

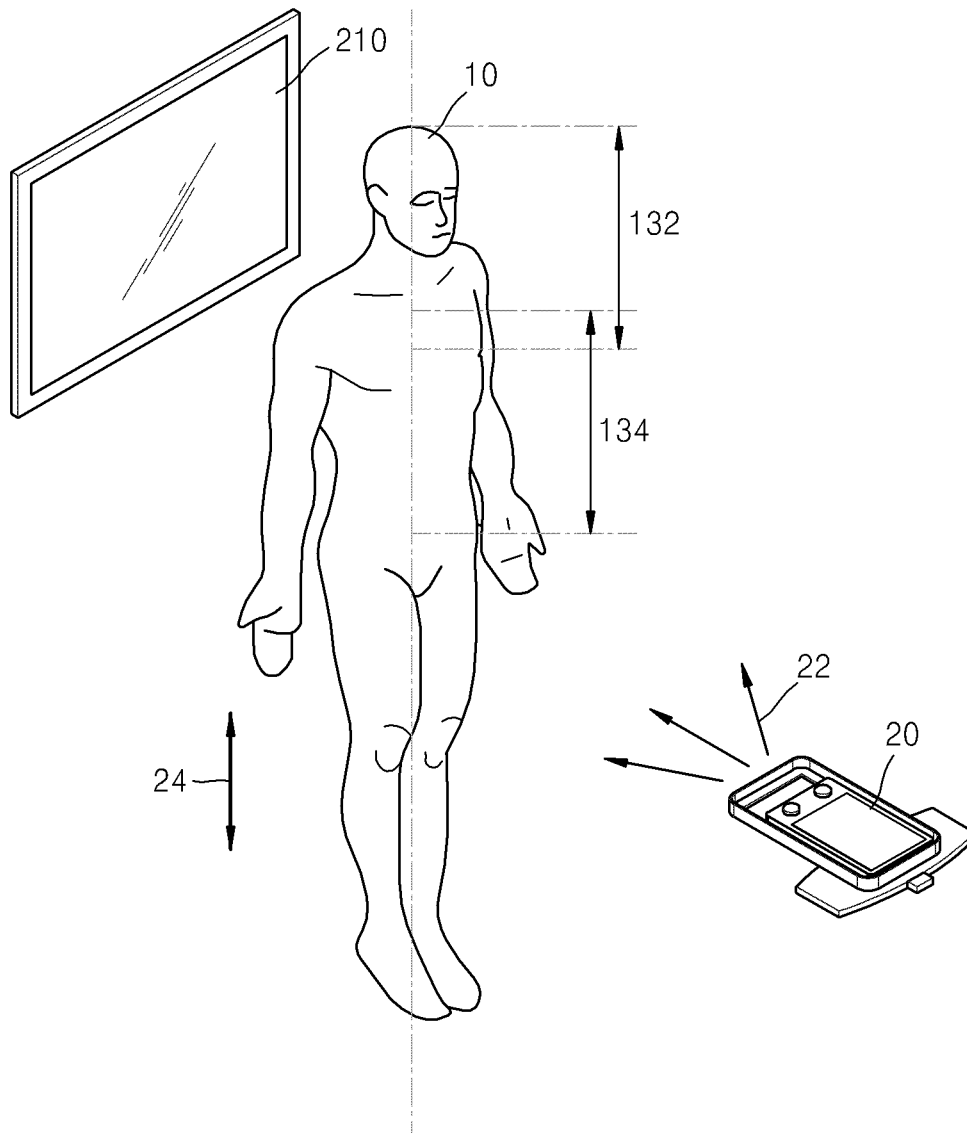

[Fig. 4]

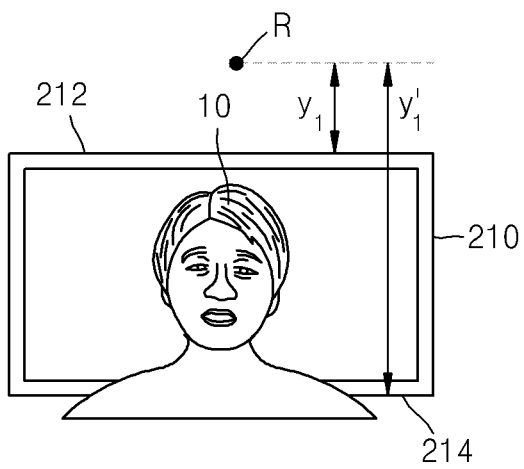

[Fig. 5]

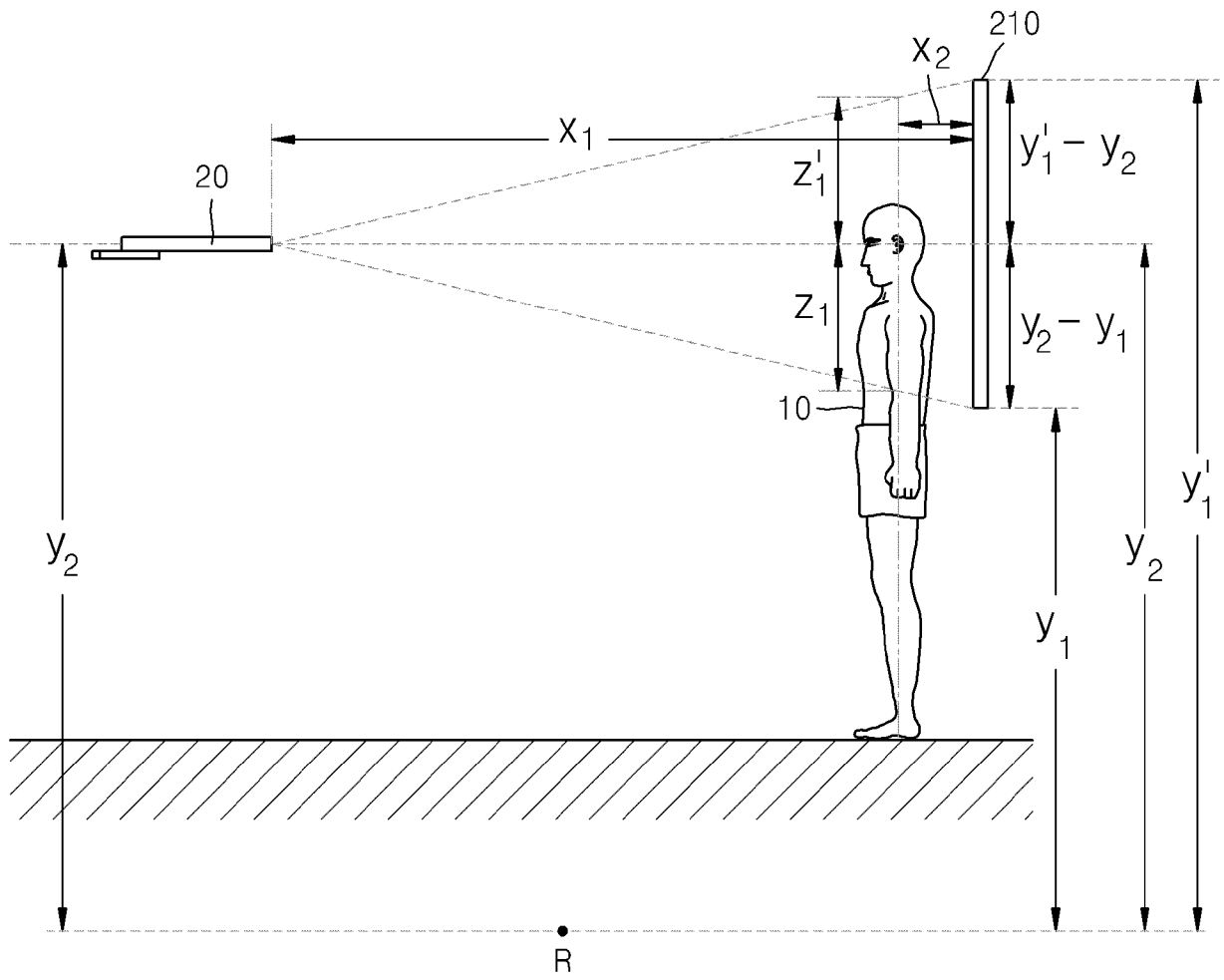

[Fig. 6]

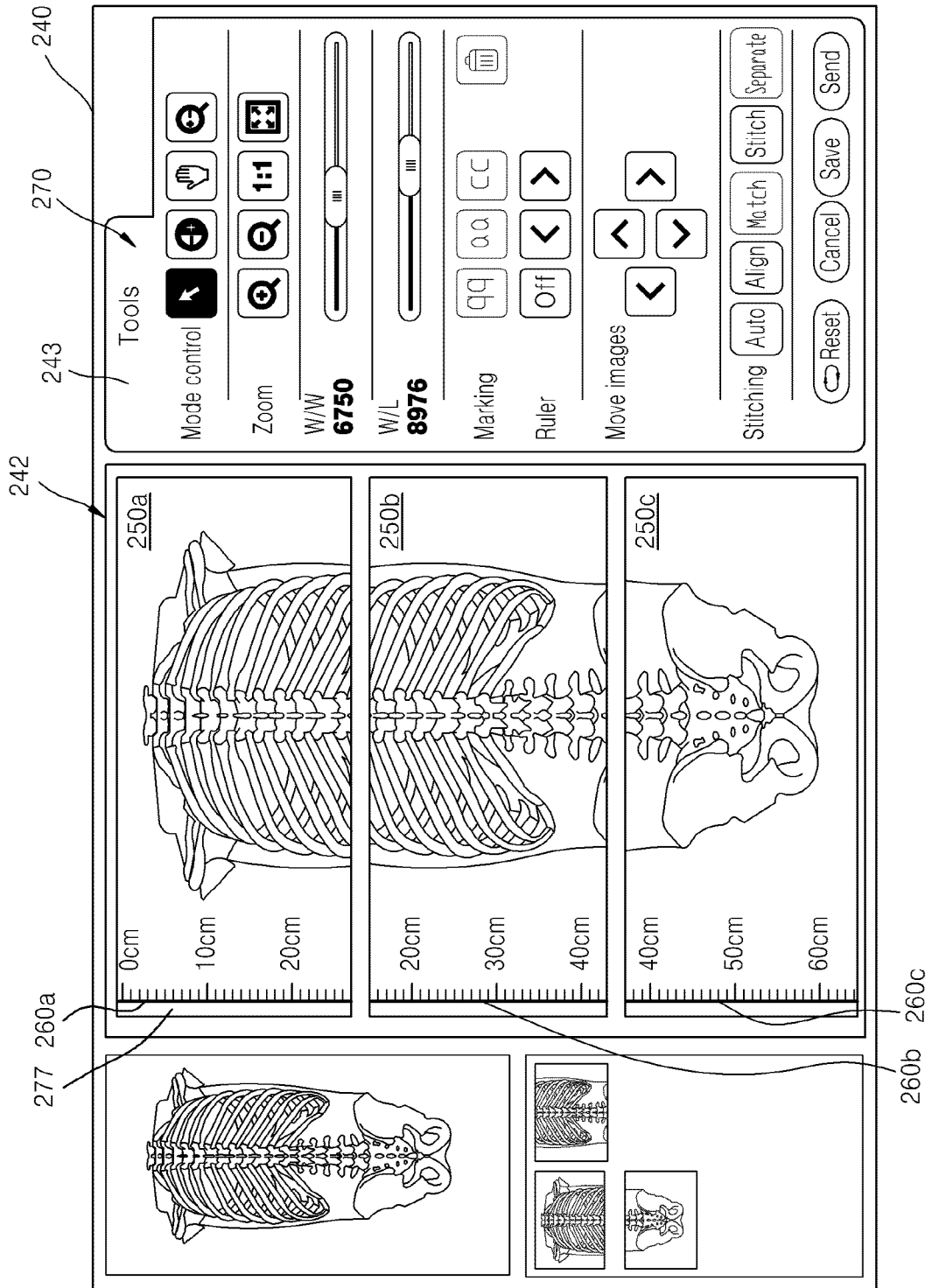

[Fig. 7]

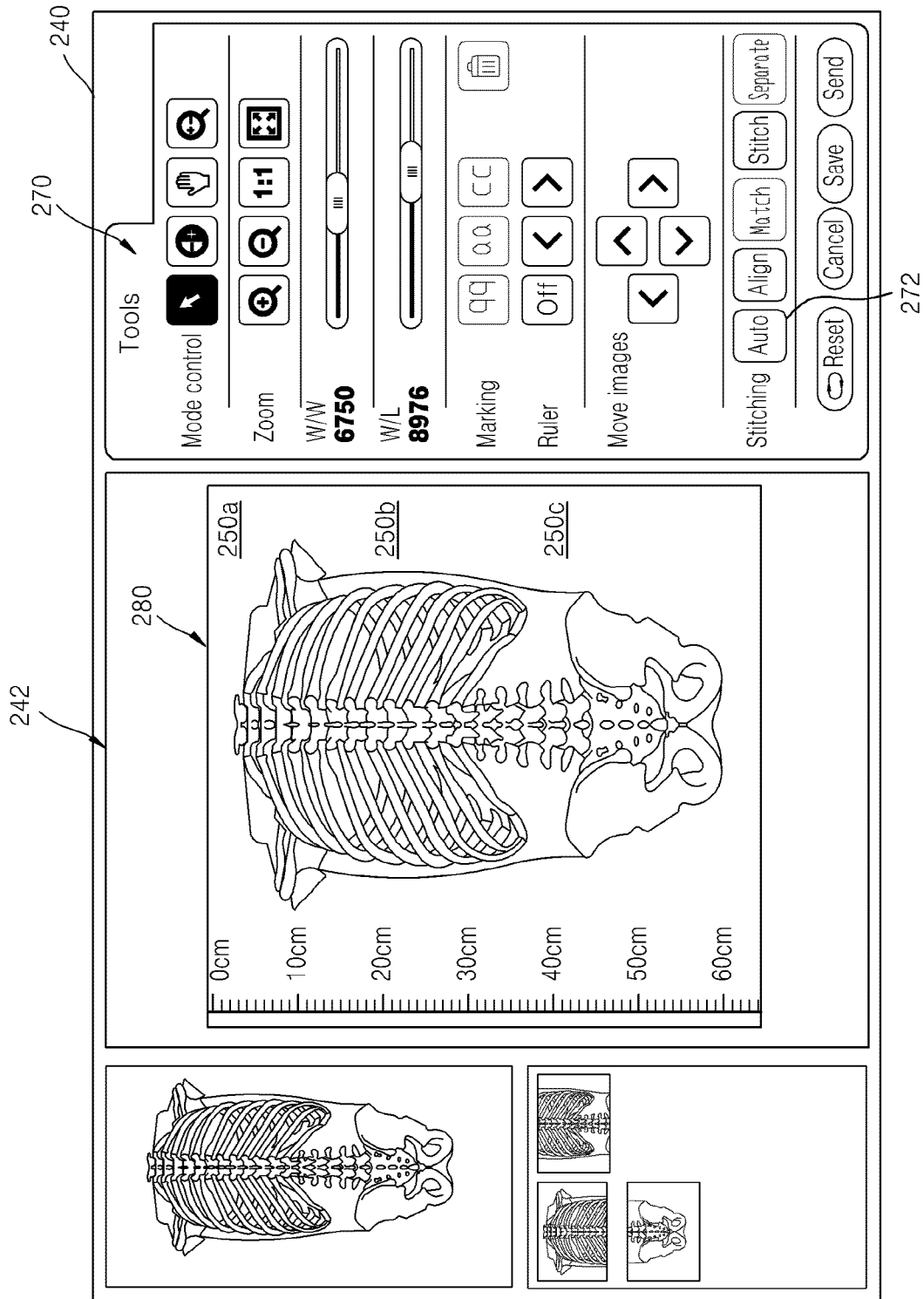

[Fig. 8]

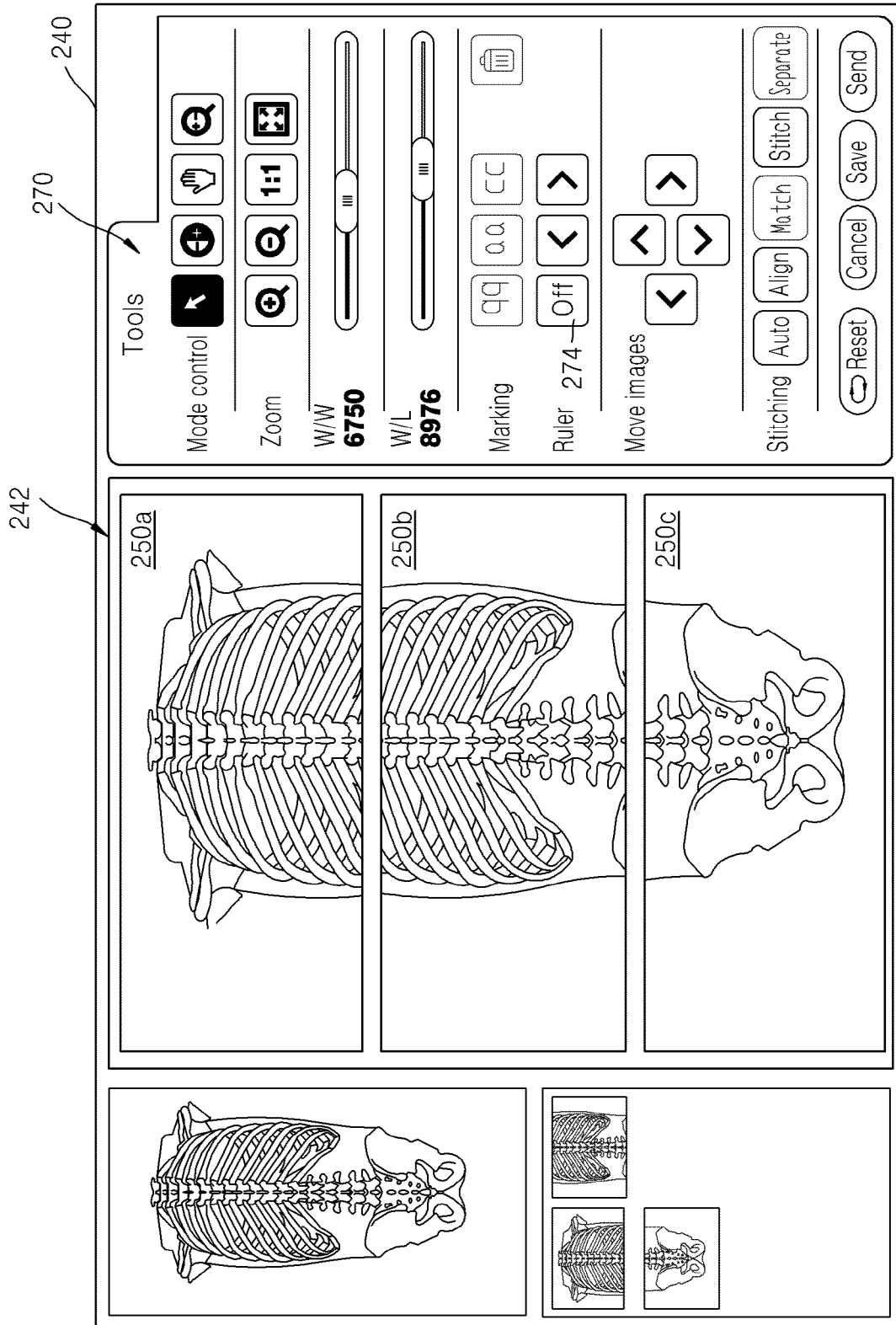

[Fig. 9]

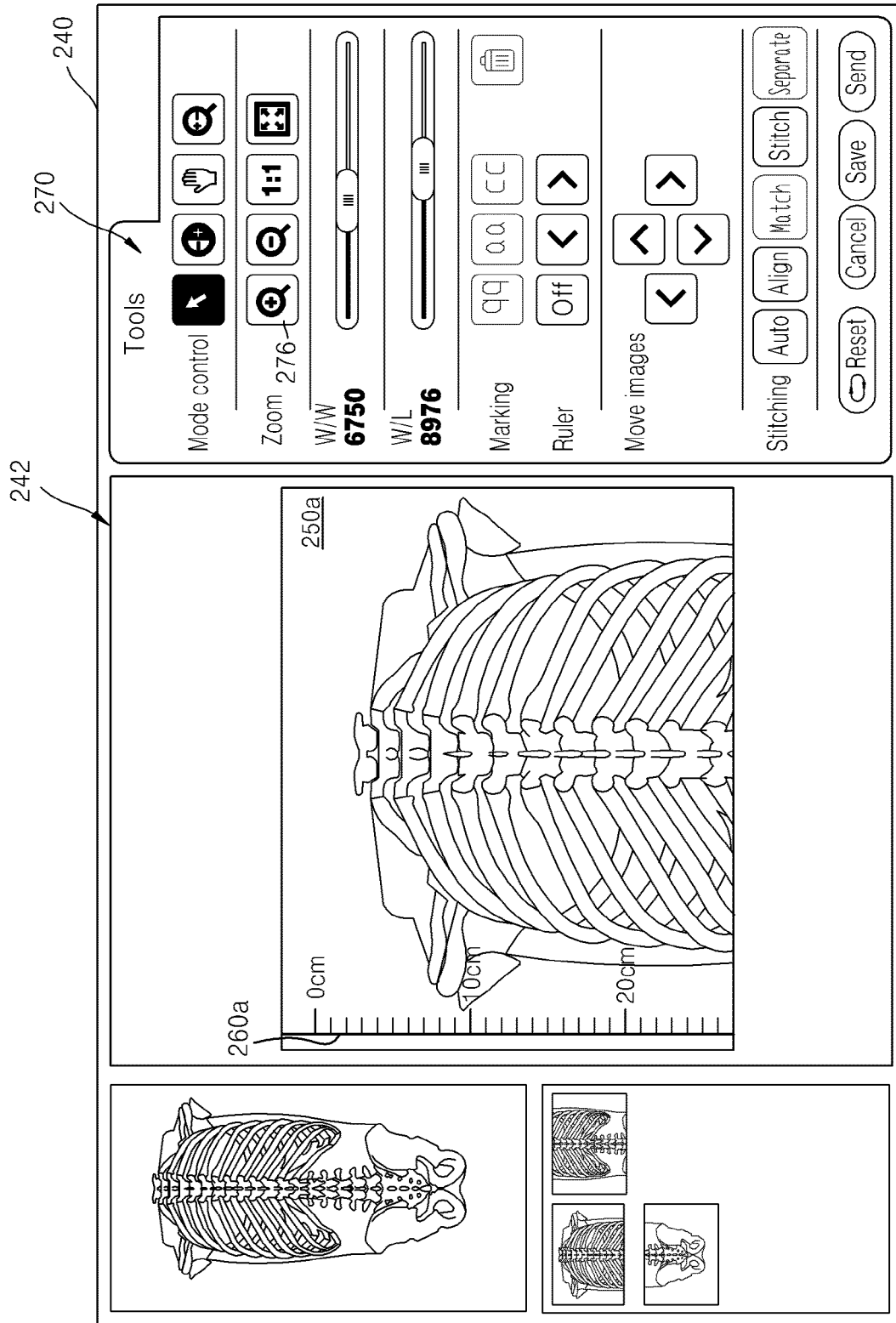

[Fig. 10]

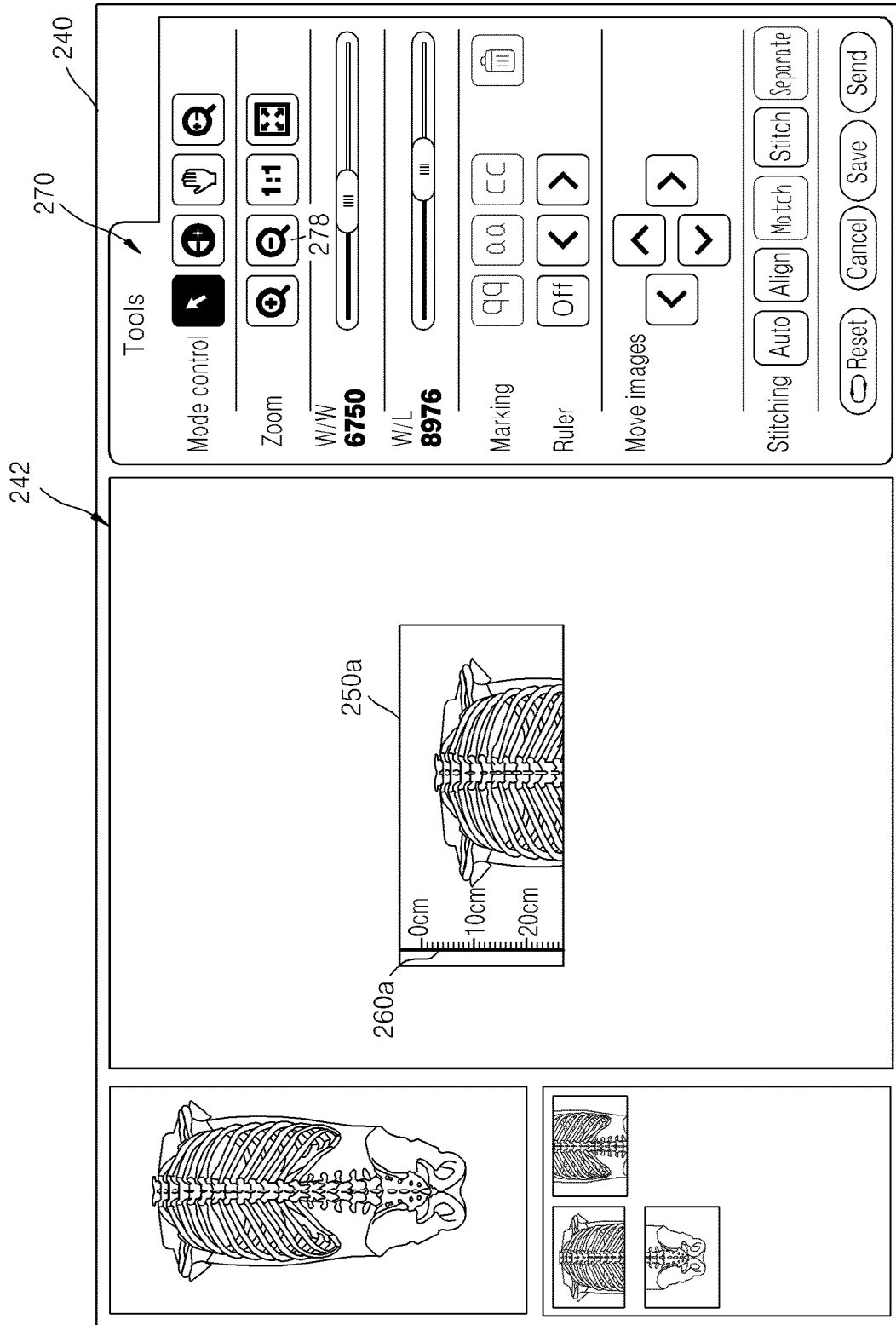

[Fig. 11]

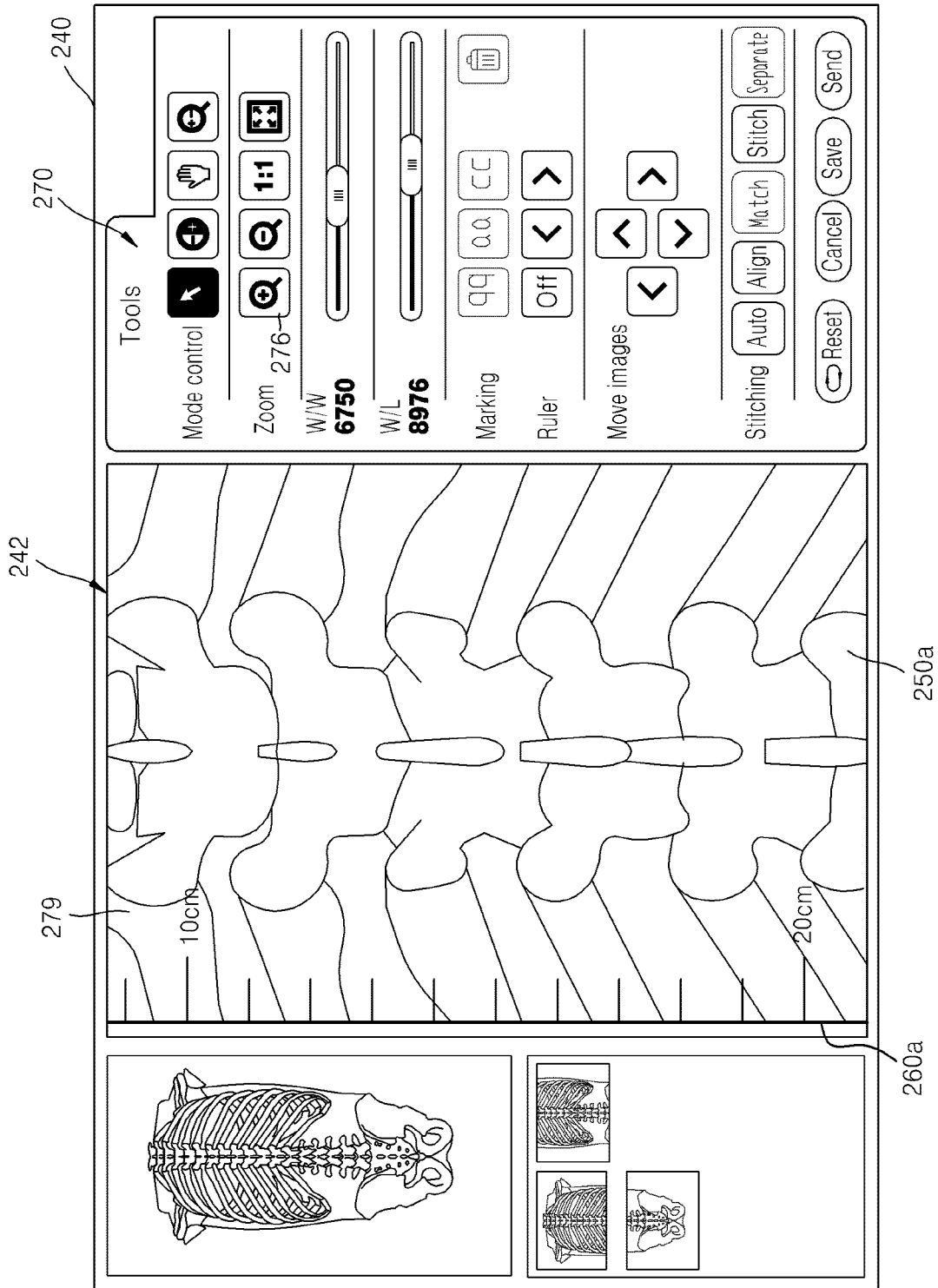

[Fig. 12a]

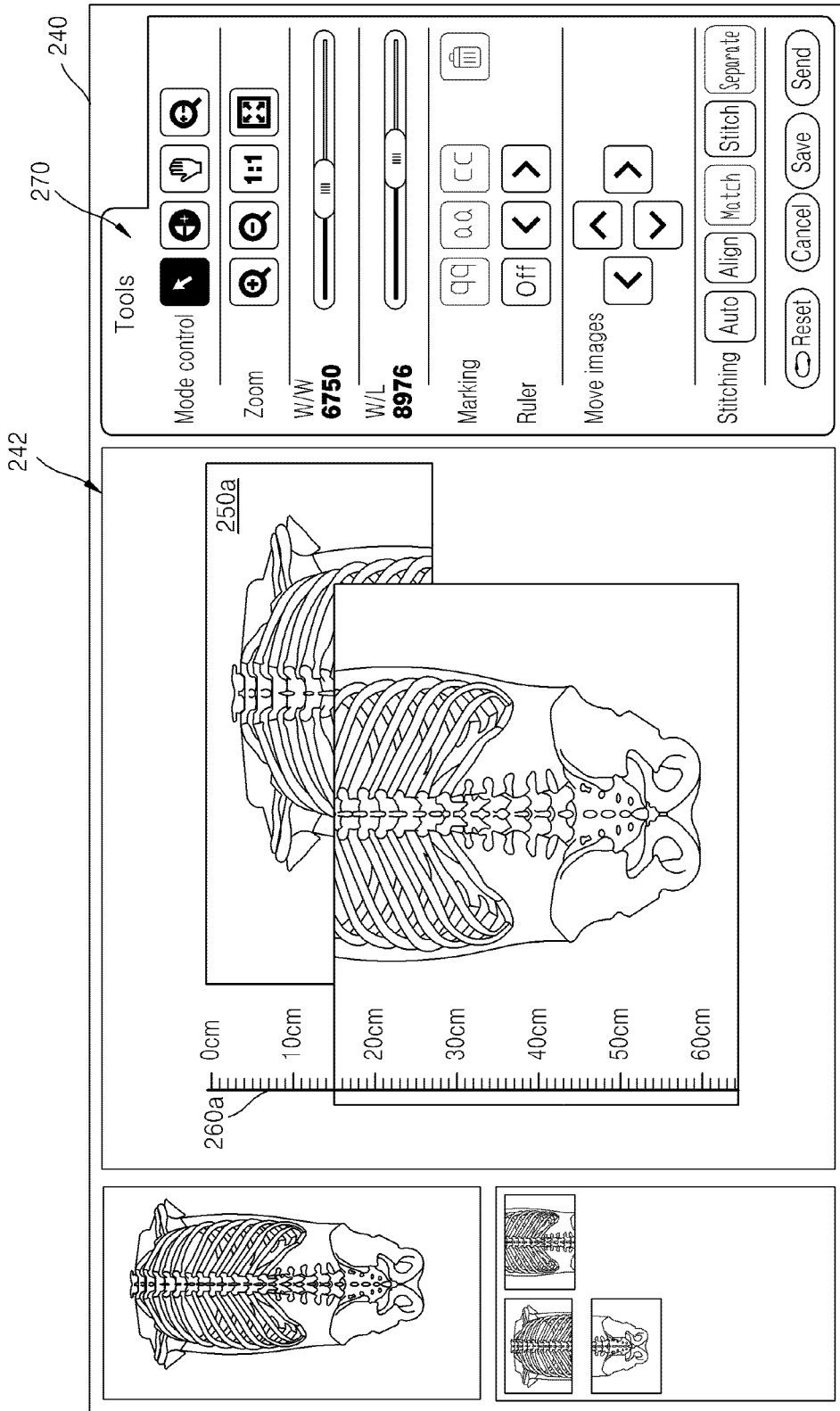

[Fig. 12b]

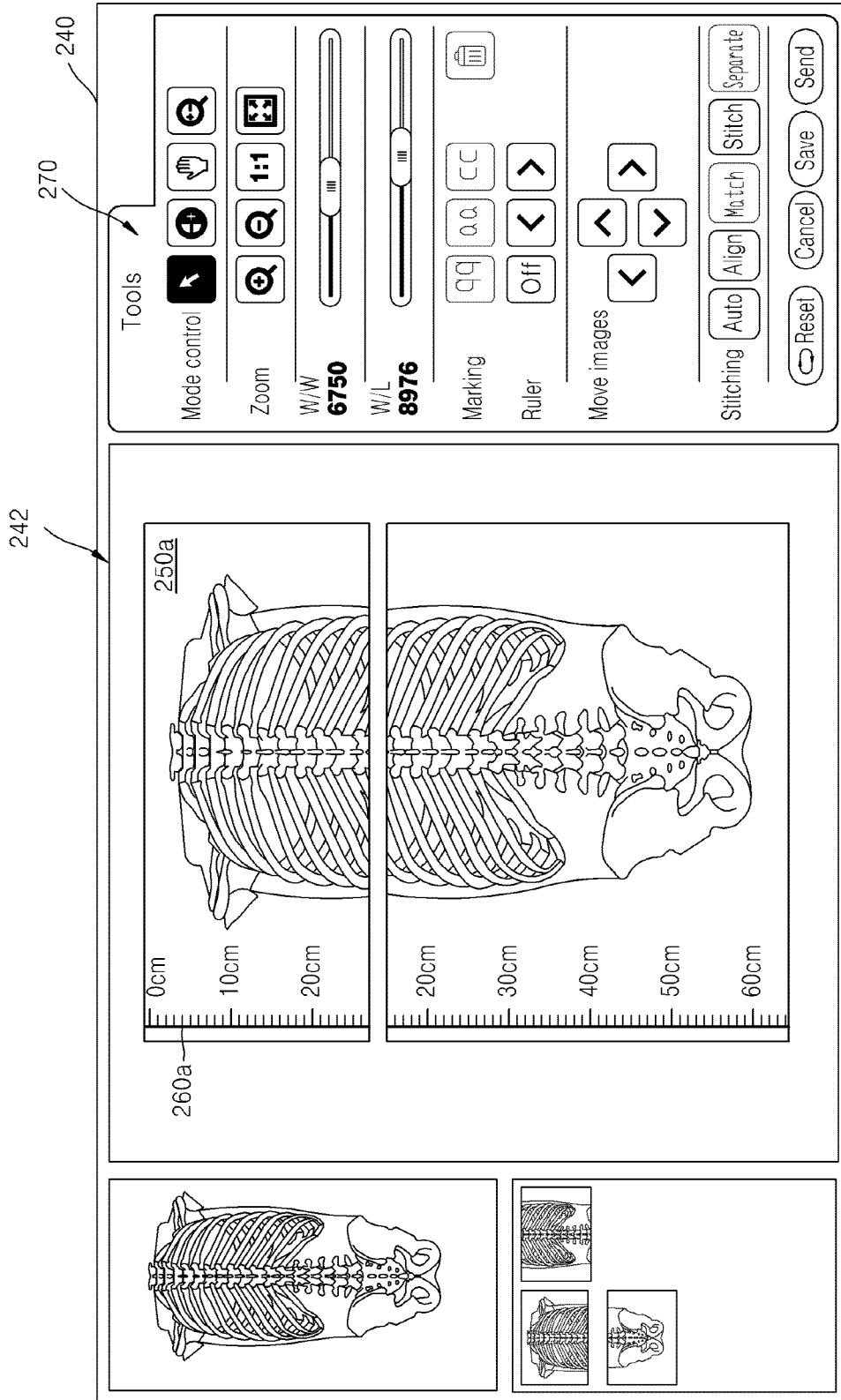

[Fig. 13]

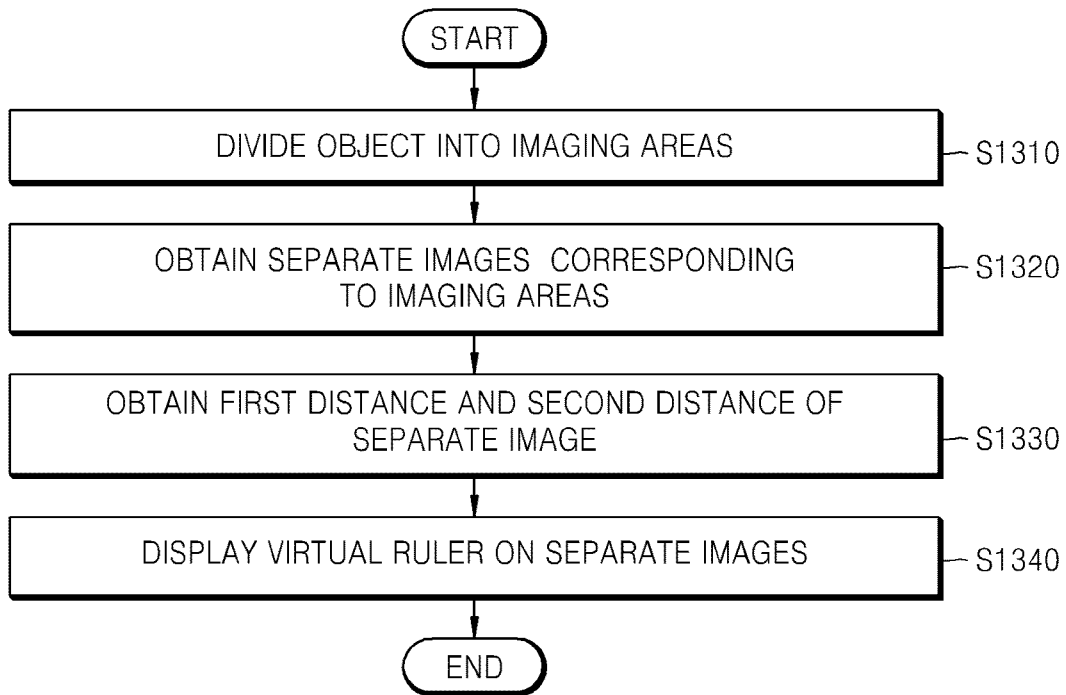

[Fig. 14]

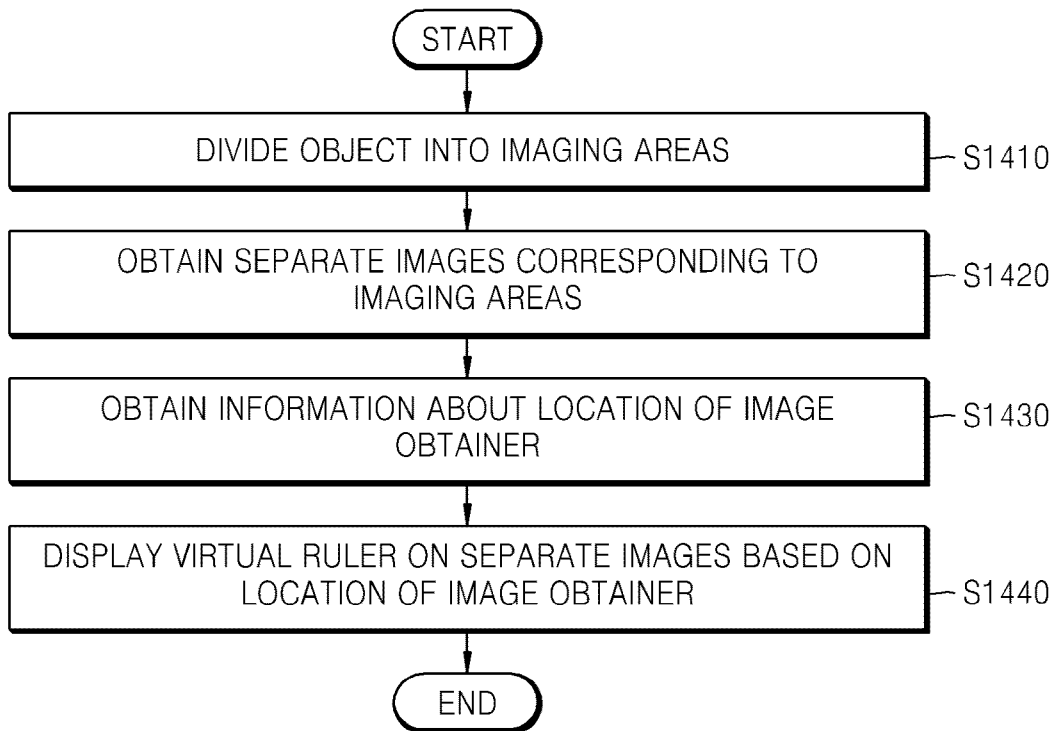

[Fig. 15]

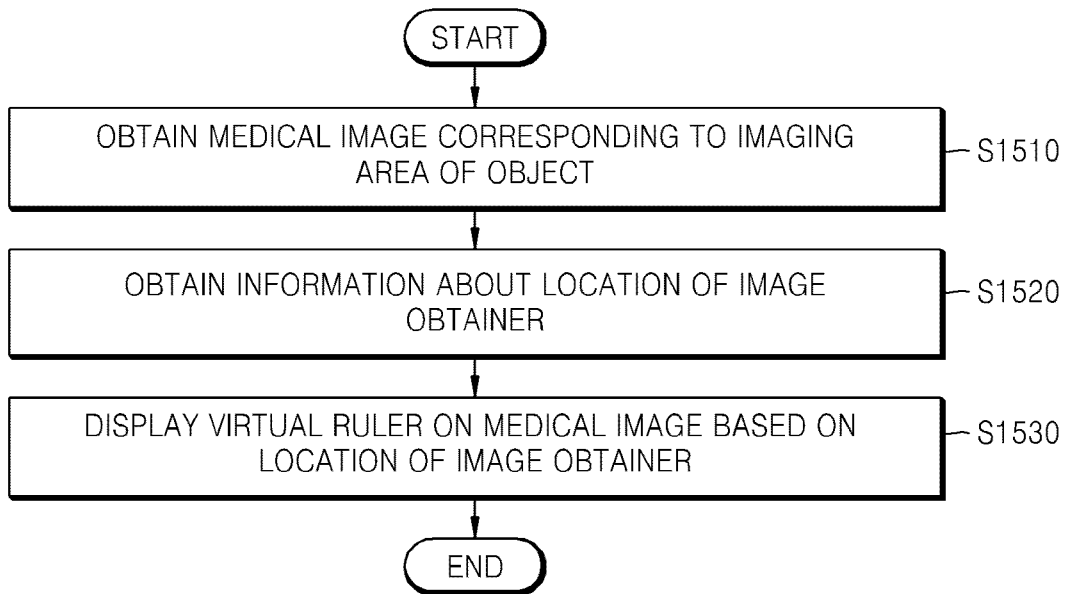

[Fig. 16]

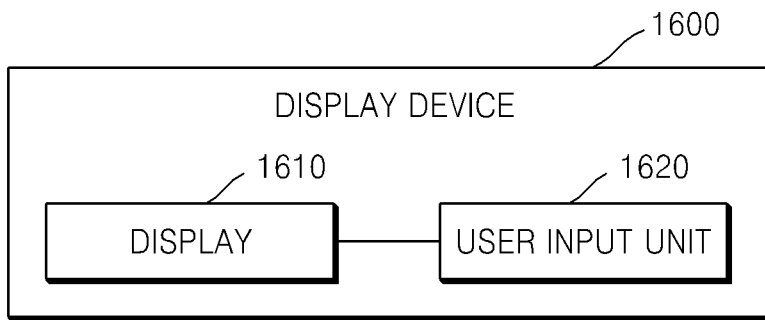

[Fig. 17]

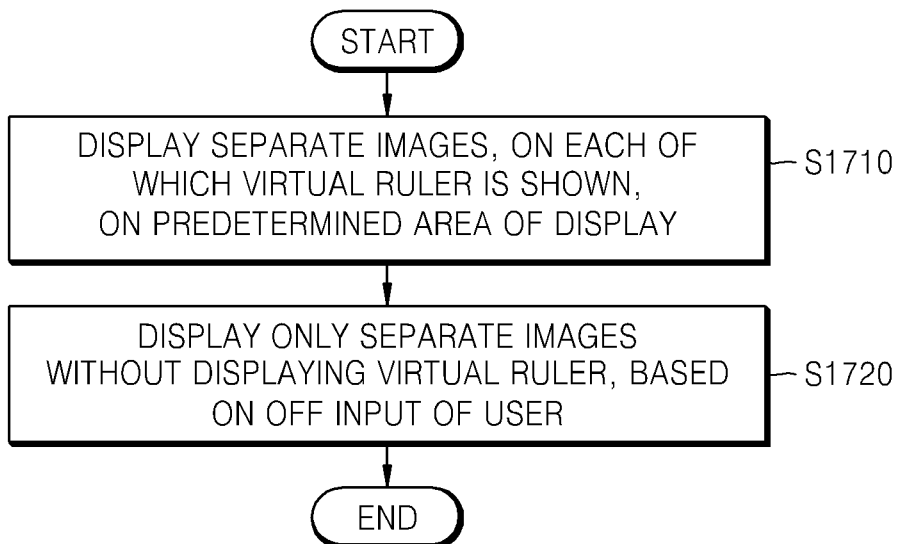

A. CLASSIFICATION OF SUBJECT MATTER**H04N 5/262(2006.01)i, A61B 6/00(2006.01)i**

According to International Patent Classification (IPC) or to both national classification and IPC

B. FIELDS SEARCHED

Minimum documentation searched (classification system followed by classification symbols)

H04N 5/262; A61B 5/05; G06K 9/00; G09G 5/00; A61B 5/00; A61B 6/00

Documentation searched other than minimum documentation to the extent that such documents are included in the fields searched

Korean utility models and applications for utility models

Japanese utility models and applications for utility models

Electronic data base consulted during the international search (name of data base and, where practicable, search terms used)

eKOMPASS(KIPO internal) & Keywords: MRI, images, separate, virtual ruler, display

C. DOCUMENTS CONSIDERED TO BE RELEVANT

| Category* | Citation of document, with indication, where appropriate, of the relevant passages | Relevant to claim No. |
|-----------|---|-----------------------|
| Y | US 2007-0038073 A1 (CHARLES A. MISTRETTA) 15 February 2007 See abstract, paragraphs [0067]-[0070], claim 1 and figure 7. | 1, 15 |
| A | | 2-14 |
| Y | US 2011-0109650 A1 (KEVIN A. KREEGER et al.) 12 May 2011 See paragraphs [0057]-[0061], claim 11 and figures 4-6. | 1, 15 |
| A | | 2-14 |
| A | US 2005-0251021 A1 (LEON KAUFMAN et al.) 10 November 2005 See claim 31 and figure 17. | 1-15 |
| A | US 6097833 A (STEVEN LOBREGT et al.) 01 August 2000 See column 10, lines 37-59 and figures 2, 6b. | 1-15 |
| A | US 6151521 A (QINGLIAN GUO et al.) 21 November 2000 See abstract, claim 1 and figures 7(a)-7(d). | 1-15 |

 Further documents are listed in the continuation of Box C. See patent family annex.

* Special categories of cited documents:

"A" document defining the general state of the art which is not considered to be of particular relevance

"E" earlier application or patent but published on or after the international filing date

"L" document which may throw doubts on priority claim(s) or which is cited to establish the publication date of citation or other special reason (as specified)

"O" document referring to an oral disclosure, use, exhibition or other means

"P" document published prior to the international filing date but later than the priority date claimed

"T" later document published after the international filing date or priority date and not in conflict with the application but cited to understand the principle or theory underlying the invention

"X" document of particular relevance; the claimed invention cannot be considered novel or cannot be considered to involve an inventive step when the document is taken alone

"Y" document of particular relevance; the claimed invention cannot be considered to involve an inventive step when the document is combined with one or more other such documents, such combination being obvious to a person skilled in the art

"&" document member of the same patent family

Date of the actual completion of the international search

15 October 2013 (15.10.2013)

Date of mailing of the international search report

16 October 2013 (16.10.2013)

Name and mailing address of the ISA/KR



 Korean Intellectual Property Office
 189 Cheongsa-ro, Seo-gu, Daejeon Metropolitan City,
 302-701, Republic of Korea

Facsimile No. +82-42-472-7140

Authorized officer

PARK Hye Lyun

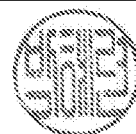
Telephone No. +82-42-481-3463



INTERNATIONAL SEARCH REPORT

Information on patent family members

International application No.

PCT/KR2013/006548

| Patent document cited in search report | Publication date | Patent family member(s) | Publication date |
|---|---------------------|----------------------------|---------------------|
| US 2007-0038073 A1 | 15/02/2007 | AT 448531 T | 15/11/2009 |
| | | CN 101248458 A | 20/08/2008 |
| | | CN 101248458 B | 15/08/2012 |
| | | CN 101248458 C0 | 20/08/2008 |
| | | CN 101263398 A0 | 10/09/2008 |
| | | CN 101263398 B | 18/07/2012 |
| | | CN 101273276 A0 | 24/09/2008 |
| | | CN 101283288 A0 | 08/10/2008 |
| | | CN 101283288 B | 26/12/2012 |
| | | CN 101287995 A0 | 15/10/2008 |
| | | CN 101287996 A0 | 15/10/2008 |
| | | CN 101287997 A0 | 15/10/2008 |
| | | CN 101287997 B | 16/11/2011 |
| | | CN 101297214 A0 | 29/10/2008 |
| | | CN 101297214 B | 29/06/2011 |
| | | CN 101300600 A | 05/11/2008 |
| | | CN 101300600 C0 | 05/11/2008 |
| | | DE 602006010388 D1 | 24/12/2009 |
| | | EP 1902328 A1 | 26/03/2008 |
| | | EP 1902424 A2 | 26/03/2008 |
| | | EP 1902424 B1 | 11/11/2009 |
| | | EP 1904977 A1 | 02/04/2008 |
| | | EP 1904977 B1 | 15/12/2010 |
| | | EP 1927007 A1 | 04/06/2008 |
| | | EP 1927008 A1 | 04/06/2008 |
| | | EP 1927009 A1 | 04/06/2008 |
| | | EP 1927010 A2 | 04/06/2008 |
| | | EP 1927011 A1 | 04/06/2008 |
| | | EP 1946139 A1 | 23/07/2008 |
| | | EP 2495580 A1 | 05/09/2012 |
| | | HK 1124666 A1 | 26/04/2013 |
| | | JP 05047960 B2 | 10/10/2012 |
| | | JP 05113060 B2 | 09/01/2013 |
| | | JP 05113061 B2 | 09/01/2013 |
| | | JP 05113062 B2 | 09/01/2013 |
| | | JP 05123191 B2 | 16/01/2013 |
| | | JP 05123192 B2 | 16/01/2013 |
| | | JP 05167125 B2 | 21/03/2013 |
| | | JP 05236464 B2 | 17/07/2013 |
| | | JP 2009-500114 A | 08/01/2009 |
| | | JP 2009-500115 A | 08/01/2009 |
| | | JP 2009-500116 A | 08/01/2009 |
| | | JP 2009-508634 A | 05/03/2009 |
| | | JP 2009-508635 A | 05/03/2009 |
| | | JP 2009-508654 A | 05/03/2009 |
| | | JP 2009-508655 A | 05/03/2009 |
| | | JP 2009-508656 A | 05/03/2009 |
| JP 2009-508660 A | 05/03/2009 | | |
| US 2007-0009080 A1 | 11/01/2007 | | |

INTERNATIONAL SEARCH REPORT

Information on patent family members

International application No.

PCT/KR2013/006548

| Patent document cited in search report | Publication date | Patent family member(s) | Publication date |
|--|------------------|-------------------------|------------------|
| | | US 2007-0106149 A1 | 10/05/2007 |
| | | US 2007-0156044 A1 | 05/07/2007 |
| | | US 2007-0167707 A1 | 19/07/2007 |
| | | US 2007-0167728 A1 | 19/07/2007 |
| | | US 7519412 B2 | 14/04/2009 |
| | | US 7545901 B2 | 09/06/2009 |
| | | US 7647088 B2 | 12/01/2010 |
| | | US 7711166 B2 | 04/05/2010 |
| | | US 7865227 B2 | 04/01/2011 |
| | | US 7917189 B2 | 29/03/2011 |
| | | US 7917190 B2 | 29/03/2011 |
| | | WO 2007-008528 A2 | 18/01/2007 |
| | | WO 2007-008528 A3 | 19/04/2007 |
| | | WO 2007-008530 A1 | 18/01/2007 |
| | | WO 2007-008532 A1 | 18/01/2007 |
| | | WO 2007-037937 A1 | 05/04/2007 |
| | | WO 2007-037951 A2 | 05/04/2007 |
| | | WO 2007-037951 A3 | 18/05/2007 |
| | | WO 2007-038203 A1 | 05/04/2007 |
| | | WO 2007-038205 A1 | 05/04/2007 |
| | | WO 2007-038206 A1 | 05/04/2007 |
| | | WO 2007-038227 A1 | 05/04/2007 |
| US 2011-0109650 A1 | 12/05/2011 | EP 2486503 A2 | 15/08/2012 |
| | | EP 2535829 A2 | 19/12/2012 |
| | | EP 2535829 A3 | 10/07/2013 |
| | | US 2011-0110576 A1 | 12/05/2011 |
| | | US 8326012 B2 | 04/12/2012 |
| | | WO 2011-044295 A2 | 14/04/2011 |
| | | WO 2011-044295 A3 | 11/08/2011 |
| US 2005-0251021 A1 | 10/11/2005 | US 2003-0018245 A1 | 23/01/2003 |
| | | US 6901277 B2 | 31/05/2005 |
| US 06097833 A | 01/08/2000 | EP 0655861 A1 | 31/05/1995 |
| | | EP 0655861 B1 | 02/08/2000 |
| US 06151521 A | 21/11/2000 | JP 11-155142 A | 08/06/1999 |