

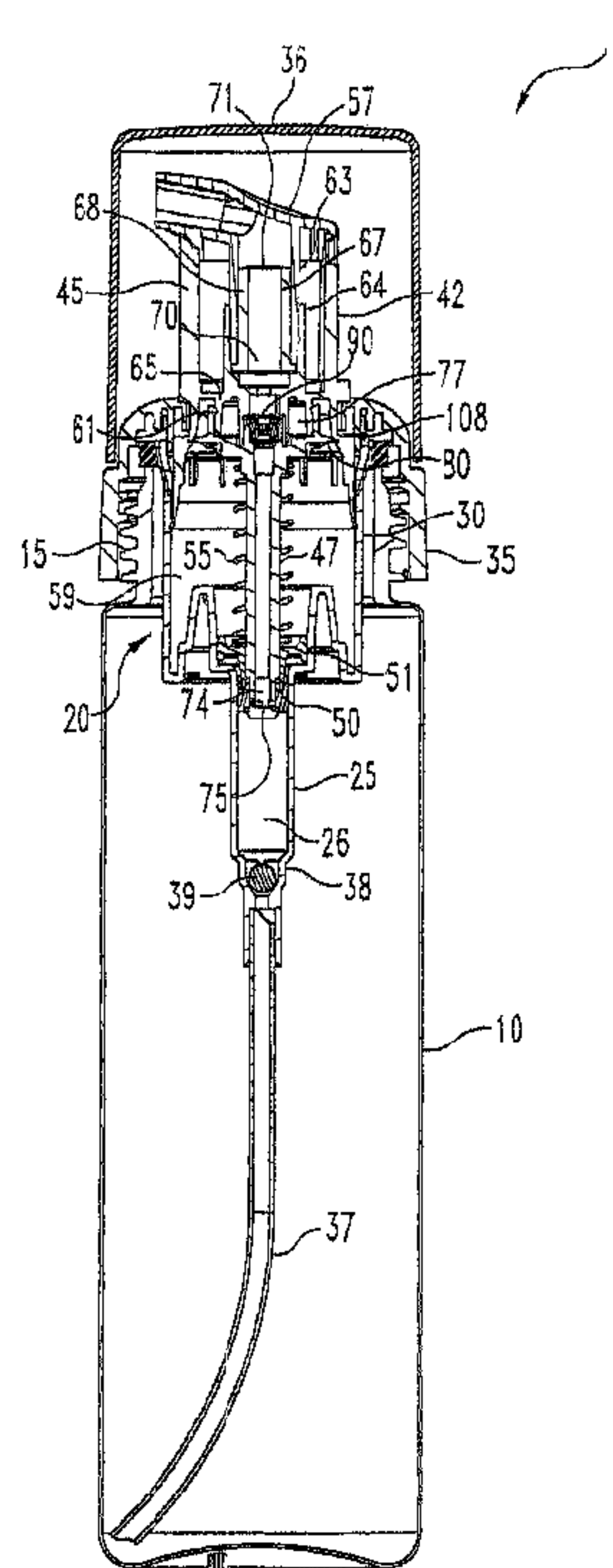

(86) **Date de dépôt PCT/PCT Filing Date:** 2006/01/17
 (87) **Date publication PCT/PCT Publication Date:** 2006/08/10
 (45) **Date de délivrance/Issue Date:** 2015/06/02
 (85) **Entrée phase nationale/National Entry:** 2007/07/06
 (86) **N° demande PCT/PCT Application No.:** US 2006/001502
 (87) **N° publication PCT/PCT Publication No.:** 2006/083534
 (30) **Priorité/Priority:** 2005/01/14 (US60/644,387)

(51) **Cl.Int./Int.Cl. B65D 83/76** (2006.01),
A47K 5/14 (2006.01), **B05B 11/02** (2006.01)
 (72) **Inventeurs/Inventors:**
 JAHAN, ROWSHAN, US;
 VAN ZUILEN, DAVID, US
 (73) **Propriétaire/Owner:**
 RIEKE CORPORATION, US
 (74) **Agent:** SMART & BIGGAR

(54) **Titre : JOINT DE VERROUILLAGE EN POSITON HAUT POUR UN DISTRIBUTEUR A POMPE**
 (54) **Title: UP-LOCK SEAL FOR DISPENSER PUMP**



(57) **Abrégé/Abstract:**

Current designs of dispensers often do not allow for proper ventilation. Additionally, current designs often do not permit proper liquid sealing during shipment. The disclosed apparatus can overcome these shortcomings. This foam dispenser comprises a container, a cylinder device, a collar connected to the cylinder device, the collar operably connecting the container with the cylinder device, and a seal located on the collar, wherein the seal expands under compression to a locked position to create an airtight and liquid tight seal substantially preventing air and liquid from entering or exiting the cylinder device.

(12) INTERNATIONAL APPLICATION PUBLISHED UNDER THE PATENT COOPERATION TREATY (PCT)

(19) World Intellectual Property Organization
International Bureau(43) International Publication Date
10 August 2006 (10.08.2006)

PCT

(10) International Publication Number
WO 2006/083534 A2(51) International Patent Classification:
B67B 5/00 (2006.01)(74) Agent: **BENNI, Todd, A.**; McDonald Hopkins Co., LPA,
600 Superior Ave., E., Suite 2100, Cleveland, OH 44114
(US).

(21) International Application Number:

PCT/US2006/001502

(81) Designated States (*unless otherwise indicated, for every kind of national protection available*): AE, AG, AL, AM, AT, AU, AZ, BA, BB, BG, BR, BW, BY, BZ, CA, CH, CN, CO, CR, CU, CZ, DE, DK, DM, DZ, EC, EE, EG, ES, FI, GB, GD, GE, GH, GM, HR, HU, ID, IL, IN, IS, JP, KE, KG, KM, KN, KP, KR, KZ, LC, LK, LR, LS, LT, LU, LV, LY, MA, MD, MG, MK, MN, MW, MX, MZ, NA, NG, NI, NO, NZ, OM, PG, PH, PL, PT, RO, RU, SC, SD, SE, SG, SK, SL, SM, SY, TJ, TM, TN, TR, TT, TZ, UA, UG, US, UZ, VC, VN, YU, ZA, ZM, ZW.

(22) International Filing Date: 17 January 2006 (17.01.2006)

(25) Filing Language: English

(26) Publication Language: English

(30) Priority Data:
60/644,387 14 January 2005 (14.01.2005) US(71) Applicant (*for all designated States except US*): **RIEKE CORPORATION** [US/US]; 500 West Seventh Street, Auburn, IN 46706 (US).(84) Designated States (*unless otherwise indicated, for every kind of regional protection available*): ARIPO (BW, GH, GM, KE, LS, MW, MZ, NA, SD, SL, SZ, TZ, UG, ZM, ZW), Eurasian (AM, AZ, BY, KG, KZ, MD, RU, TJ, TM), European (AT, BE, BG, CH, CY, CZ, DE, DK, EE, ES, FI, FR, GB, GR, HU, IE, IS, IT, LT, LU, LV, MC, NL, PL, PT,(72) Inventors: **JAHAN, Rowshan**; 10008 Jefferson Way, Fort Wayne, IN 46825 (US). **VAN ZUILEN, David**; 240 LN 800 Snow Lake, Fremont, IN 46737 (US).

[Continued on next page]

(54) Title: UP-LOCK SEAL FOR DISPENSER PUMP

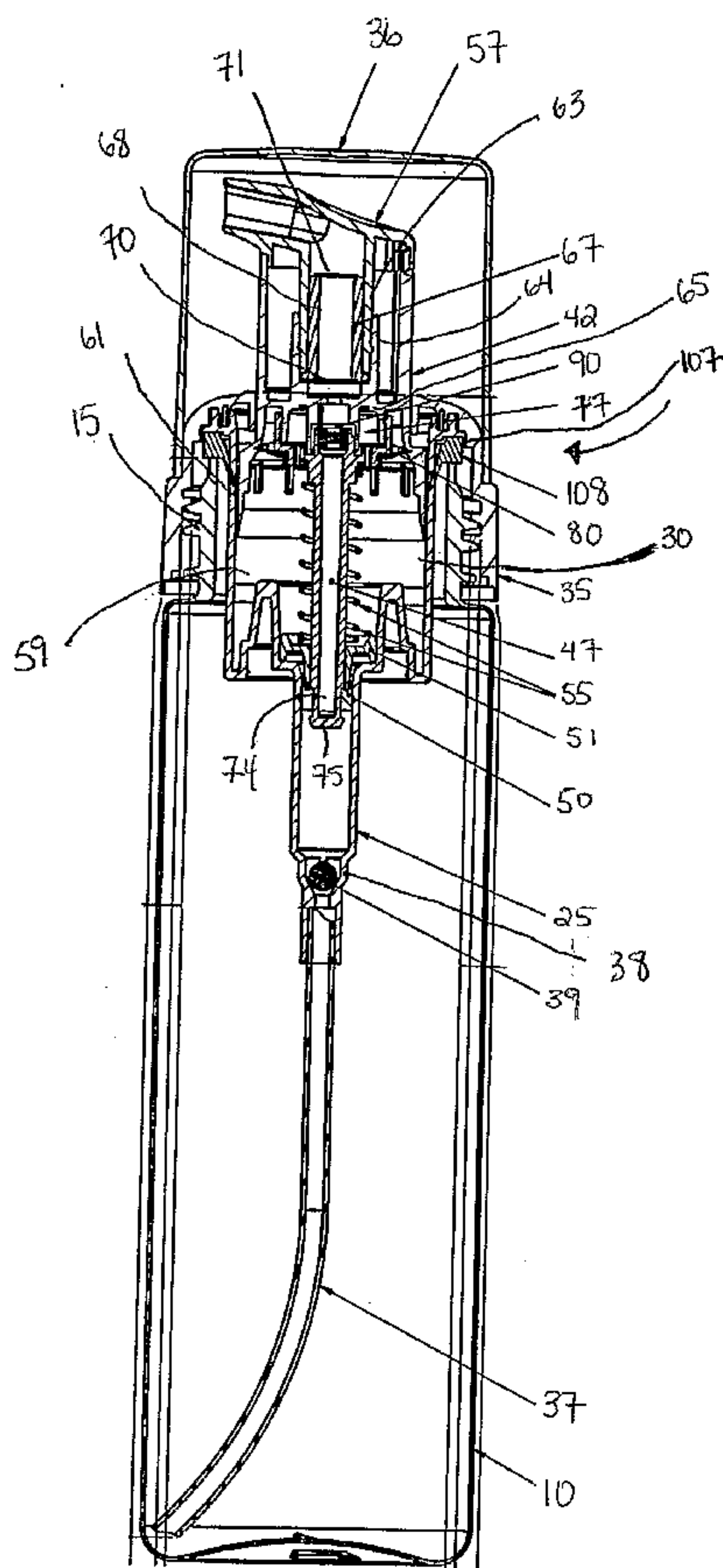

(57) Abstract: Current designs of dispensers often do not allow for proper ventilation. Additionally, current designs often do not permit proper liquid sealing during shipment. The disclosed apparatus can overcome these shortcomings. This foam dispenser comprises a container, a cylinder device, a collar connected to the cylinder device, the collar operably connecting the container with the cylinder device, and a seal located on the collar, wherein the seal expands under compression to a locked position to create an airtight and liquid tight seal substantially preventing air and liquid from entering or exiting the cylinder device.

WO 2006/083534 A2

WO 2006/083534 A2



RO, SE, SI, SK, TR), OAPI (BF, BJ, CF, CG, CI, CM, GA, GN, GQ, GW, ML, MR, NE, SN, TD, TG).

For two-letter codes and other abbreviations, refer to the "Guidance Notes on Codes and Abbreviations" appearing at the beginning of each regular issue of the PCT Gazette.

Published:

— *without international search report and to be republished upon receipt of that report*

61211-2093

UP-LOCK SEAL FOR DISPENSER PUMP

FIELD OF THE INVENTION

The present invention relates generally to hand-operated dispensers, and, more particularly, to foamer dispensers having a seal to create an airtight and liquid tight seal
5 substantially preventing air and liquid from entering or exiting the dispenser.

BACKGROUND

Over the last 15 years or so the use of foam dispensers based on aerosols using pressurized gas has declined steeply for environmental reasons. This has lead to the development of foaming dispensers that exploit a manual pumping action to blend air and
10 liquid to create foam.

A particular category of such known dispensers, also known as foaming dispensers or foamers, provides both a liquid pump and an air pump mounted at the top of a container. The liquid pump has a liquid pump chamber defined between a liquid cylinder and a liquid piston, and the air pump has an air pump chamber defined between an air cylinder and
15 an air piston. These components are typically arranged concentrically around a plunger axis of the pump. The liquid piston and air piston are reciprocal in their respective cylinders by the action of a pump plunger. Typically the two pistons are integrated with the plunger. An air inlet valve and a liquid inlet valve are provided for the air chamber and liquid chamber. An air discharge passage and a liquid discharge passage lead from the respective chambers to
20 an outlet passage by way of a permeable foam-generating element, normally one or more mesh layers, through which the air and liquid pass as a mixture. Preferably the air discharge passage and liquid discharge passage meet in a mixing chamber or mixing region immediately upstream of the permeable foam-generating element.

Current designs of dispenser pumps do not allow for proper ventilation to the
25 mating bottle in a pump and bottle system. The failure to achieve proper ventilation prevents vacuum build-up inside the mating liquid bottle as liquid is pumped out of the liquid bottle. In addition, current designs do not permit proper liquid sealing during shipment. Often, the

61211-2093

liquid in the liquid bottles will leak out during transportation wasting the liquid and creating an undesirable mess.

SUMMARY OF THE INVENTION

Accordingly, a foam dispenser is disclosed herein. This foam dispenser
5 comprises a container, a cylinder device, a collar connected to the cylinder device, the collar operably connecting the container with the cylinder device, and a seal located on the collar, wherein the seal expands under compression to a locked position to create an airtight and liquid tight seal substantially preventing air and liquid from entering or exiting the cylinder device.

Another embodiment discloses a foam dispenser that comprises a container, a
10 cylinder device, a collar connected to the cylinder device to operably connect the container with the cylinder device, a plunger, at least a portion of which is mounted within the cylinder device, and a seal located within the collar and engageable with the plunger, wherein the seal is capable of being opened to vent the cylinder device and the container and is capable of being closed to substantially prevent air or liquid from entering or exiting the cylinder component.

In yet another embodiment, a foam dispenser comprises a container, a cylinder
15 device, a collar connected to the cylinder device, the collar operably connecting the container with the cylinder device, a plunger, wherein at least a portion of the plunger is mounted within the cylinder device, and a seal located on the collar, the seal comprising, an inclined wall, and a cam capable of engaging the plunger with the inclined wall to substantially prevent air or
20 liquid from entering or exiting the cylinder device and the container.

In yet another embodiment, there is provided a dispenser for a flowable
product comprising: a container; a pump mechanism constructed and arranged for dispensing said flowable product, said pump mechanism including a movable plunger; and a collar
connected to said container, said collar receiving a portion of said pump mechanism, and said
25 plunger being axially movable to an up position relative to said collar wherein, when in said up position a seal is created by engagement between said collar and said plunger.

61211-2093

In yet another embodiment, there is provided a foam dispenser comprising: a container; a pump mechanism constructed and arranged for blending a liquid and air into a foam substance, said pump mechanism including a movable plunger for dispensing said foam substance, said movable plunger including a cam rib; a collar connected to said container, said collar receiving a portion of said pump mechanism, said collar including a cam ramp which cooperates with said cam rib, wherein rotation of said plunger relative to said collar causes said cam rib to ride along a surface of said cam ramp and raise or lower said plunger accordingly, depending on the direction of rotation of said plunger; and a seal created by the abutment between a collar wall and a plunger portion, said seal existing when said plunger is in an up-lock position.

In yet another embodiment, there is provided a dispenser for a flowable product comprising: a container; a pump mechanism constructed and arranged for dispensing said flowable product, said pump mechanism including a movable plunger which includes a first engagement member; a collar connected to said container, said collar including a second engagement member and receiving a portion of said pump mechanism; said pump mechanism being movable to an up-lock position by rotation of said first engagement member relative to said second engagement member; and a seal created between a portion of said plunger and a portion of said collar when said plunger is in said up-lock position.

DESCRIPTION OF THE DRAWINGS

The operation of the foam dispenser disclosed herein may be better understood by reference to the following detailed description taken in connection with the following illustrations, wherein:

FIG. 1 is a diagrammatical view of an embodiment of a foam dispenser;

FIG. 2 is a diagrammatical view of the dispenser of the present embodiment without the container portion;

FIG. 3 is a more detailed diagrammatical view of the dispenser of FIG. 2;

FIG. 4 is a perspective view of the spout and collar of the dispenser.

61211-2093

DETAILED DESCRIPTION

As shown in the accompanying drawings, a hand-operated foam dispenser 1 is shown. The dispenser 1 is mounted on the threaded neck 15 of a conventional blow-molded cylindrical container 10. The container 10, however, need not be cylindrical. It can take any
5 sort of shape. The dispenser 1 further includes a cylinder device 20 made of material such as polypropylene, and may be of a one-piece construction or multiple-piece construction. The cylinder device 20 includes a lower, smaller-diameter liquid cylinder 25 and an upper larger-diameter air cylinder 30. The cylinder device 20 is recessed down into the neck 15 of the container 10 and held in place by a threaded retaining collar 35. In particular, the
10 collar 35 connects to the cylinder device 20 to operably connect the container 10 with the cylinder device 20. Finally, the dispenser 1 may include an overcap 36. The overcap 36 engages the collar 35 so as to retain the overcap 36 in place and prevent it from falling off.

The liquid cylinder 25 further includes a liquid chamber 26. At the bottom end of the liquid cylinder 25 a valve seat 38 is integrally formed, although it may also be non-
15 integrally connected therewith. A valve ball 39 is seated within the valve seat 38. In the current embodiment, the valve ball 39 is a 4 mm ball, but could be of different sizes depending upon the size of the valve seat 38. Finally, a dip tube or suction pipe 37 is connected to the liquid cylinder 25, or may be integrally formed therewith. The suction pipe 37 draws the liquid from the container 10 into the liquid chamber 26.

20 The cylinder device 20 includes a plunger 42 that is mounted to act reciprocally in the air and liquid cylinders 30, 25. As can be seen in FIG. 1, at least a portion of the plunger 42 is mounted within the cylinder device 20. The plunger 42 includes an integrated cap shroud 45, a projecting central stem, or more specifically, a piston 47, carrying a piston seal 50 that works in the liquid cylinder 25. A tubular piston-retaining insert 51 is
25 snapped into the base of the air cylinder 30 and the liquid piston seal 50 is trapped beneath it. This keeps the plunger 42 in the assembly. A return spring 55 is fitted around the piston 47, and acts to urge the plunger 42 to its uppermost position. Finally, the plunger 42 includes a spout 57 through which the foamed liquid is dispensed to the operator when such operator uses the foaming dispenser 1 as more specifically described below.

61211-2093

The air cylinder 30 includes an air chamber 59 and an air piston 61 that surrounds the upper part of the piston 47. It is retained by a snap fit engagement into the lower end of the cap shroud 45 of the plunger 42. This cap shroud 45 is of substantially the same diameter as the air cylinder 30. Pressing down the plunger 42 directly (without play or
5 lost motion) operates the air piston 61 in its cylinder 30.

Considering now the central parts of the plunger 42, the spout 57 communicates with an inner axial downwardly-open housing tube 63 that forms a top foamer unit housing. This housing tube 63 snap fits into an upwardly-open cylindrical tube 64 of a core insert component 65, trapping in the space between them a foam-generation element 67
10 in the passage leading to the spout 57. This foam-generation element 67 has a cylindrical plastic tube 68 fitting closely in the tube 63 and having ultrasonically welded across its open ends a disk of coarse nylon mesh 70 (bottom end) and fine nylon mesh 71 (top end).

It will be noted that in the current embodiment the piston seal 50 of the liquid piston is of the "sliding seal" type that acts as a discharge valve at the entrance to the liquid
15 discharge passage 74. That is to say, on the downstroke of the plunger 42 the piston seal 50 is displaced upwardly relative to the piston 47 and uncovers the plunger stem windows 75. This allows liquid to flow under pressure from the liquid chamber 26 into the liquid discharge passage 74 and through the foam-generation element 67 to create the foamed liquid.

The action of the pump on pressing down the plunger is as follows. At the
20 same time as liquid is driven up passage 74 as mentioned, air in the air cylinder 30 is forced-- by the decrease in volume of that chamber by the movement of air piston 61--through an air outlet valve 77 into the air discharge chamber and radially in from all directions to mix vigorously with the rapid and distributed upflow of liquid. The liquid and air flows mix as they enter the foam-generation element 67 when they pass through the progressively
25 decreasing meshes 70, 71 and merge as foam from the spout 57. The one-way action of the air inlet valve 80 prevents escape of air from the air cylinder 30 by that route, as the plunger 42 is depressed.

61211-2093

Conversely, as the plunger 42 rises again under the force of the spring 55, the liquid chamber 26 is primed in the conventional way via the inlet valve 38/39. Air flows in to occupy the air chamber defined by air cylinder 30 by downward displacement of the air inlet valve 80 relative to its valve seat under the prevailing pressure difference. Air flows into the
5 cylinder 30 from cap air space inside the cap shroud 45 that encloses the air inlet valve 80. In turn, air may enter the cap air space via channel clearances between channels of the air piston insert sleeve 90 and the bottom rim of the cap shroud 45. Alternatively, air may enter the cap shroud 45 via an upper opening in the shroud itself, the air piston insert sleeve 90 being connected air tightly.

10 The dispenser 1 further includes a seal 100, also referred to as an up-lock seal located between an inner wall 35a of the collar 35 and plunger 42. The seal 100 is located on the collar 35. The seal 100 is airtight and liquid tight, substantially preventing air or liquid from entering or exiting the dispenser 1. It is the interference (i.e., abutment) between wall 35a and plunger portion 42a which creates seal 100.

15 The required interference for sealing is provided by the action of cam 107 pulling up on the plunger 42 as the plunger 42 is turned. Cam 107 is a ramp which is located on the upper portion of the collar 35. During operation, the seal 100 acts as a valve 108 that opens and closes by actuating (or more specifically, rotating) the spout 57/plunger 42 assembly. When the plunger 42 is rotated, it creates an interference fit that causes the
20 valve 108 to close. Alternatively, the plunger 42 could be lifted to create an interference fits that causes the valve 108 to close. In particular, this interference condition results from expanding the seal 100 outward as the cam action of ramp (i.e., cam) 107 pulls the plunger 42 into wall 35a to create the seal 100. The expansion of the seal 100 increases its diameter to create a solid interference fit between the collar 35 and the plunger 42. At its maximum
25 expansion, a high stress condition is created and acts positively to close off the air passage and seal the liquid inside the container 10. Conversely, once the spout 57/plunger 42 assembly is actuated to the operational state, the interference is removed, and the seal 100 collapses in size sufficiently to positively open the valve 108 sufficiently to allow air to vent into the container 10.

61211-2093

The plunger portion of 42a of seal 100 further includes a chamfer or a radius. The chamfer/radius assists in guiding and forcing the plunger 42 to slide into contact with wall 35a to create the seal 100.

The operation of the described up-lock seal 100 is assisted by the use of the
5 two ramp segments or cams 107 on the collar 35. The plunger includes two cooperating cam ribs 115. These ramp segments 107 (see FIG. 4) raise the plunger 42 (using the cam ribs 115) as the plunger turns and rides up the ramp from a low point to a higher point at the opposite end of the ramp. An end recess or notch 106 adjacent the end of each ramp segment 107 receives a corresponding one of the cam ribs 115. The lower edge of each cam rib 115 steps
10 down into the end recess or notch to hold the plunger in this up-lock position. In the current embodiment one cam rib is bigger than the other, although they could also be of the same size. This assists functions to align the plunger 42 and dispenser head properly, especially during operation of the dispenser 1. Also included as part of collar 35 is a clearance notch or slot 104 which is adjacent the lower end of each ramp segment 107. When the plunger 42 is turned
15 such that the lower end of each cam rib 115 is aligned with a corresponding slot 104, the plunger is "open" and able to be pushed downwardly for dispensing.

The dispenser 1 of the present invention seals both liquid and air then converts to open a vent using an air lock that opens and can be re-sealed by twisting the top of the plunger shaft to the locked position. Further, the dispenser 1 provides a foaming dispenser or
20 foamer with a valve that can be opened and closed by the position of the seal. The valve prevents vacuum build-up inside a mating liquid bottle as liquid is pumped out. Finally, the dispenser can be placed in a locked position so that the plunger cannot be accidentally depressed. This is especially useful when the dispenser is transported to prevent accidental release of the liquid contained therein.

25 The invention has been described above and, obviously, modifications and alterations will occur to others upon a reading and understanding of this specification. The claims as follows are intended to include all modifications and alterations insofar as they come within the scope of the claims or the equivalent thereof.

61211-2093

CLAIMS:

1. A dispenser for a flowable product comprising:

a container;

a pump mechanism constructed and arranged for dispensing said flowable
5 product, said pump mechanism including a movable plunger; and

a collar connected to said container, said collar receiving a portion of said
pump mechanism, and said plunger being axially movable to an up position relative to said
collar wherein, when in said up position a seal is created by engagement between said collar
and said plunger.
- 10 2. The dispenser of claim 1 wherein axial movement of said plunger to said up
position is able to be effected by rotation of said plunger relative to said collar.
3. The dispenser of claim 2 wherein said collar includes a cam ramp and said
plunger includes a cooperating cam rib wherein said cam ramp and said cam rib cooperate to
move said plunger in an axial direction in response to rotation of said plunger.
- 15 4. The dispenser of claim 3 wherein said cam ramp defines a recess for receipt of
said cam rib into an up-locked condition.
5. The dispenser of claim 1 wherein said plunger includes a follower and said
collar defines a clearance slot for receipt of said follower for axial movement of said plunger
for dispensing.
- 20 6. A foam dispenser comprising:

a container;

a pump mechanism constructed and arranged for blending a liquid and air into
a foam substance, said pump mechanism including a movable plunger for dispensing said
foam substance, said movable plunger including a cam rib;

61211-2093

a collar connected to said container, said collar receiving a portion of said pump mechanism, said collar including a cam ramp which cooperates with said cam rib, wherein rotation of said plunger relative to said collar causes said cam rib to ride along a surface of said cam ramp and raise or lower said plunger accordingly, depending on the
5 direction of rotation of said plunger; and

a seal created by the abutment between a collar wall and a plunger portion, said seal existing when said plunger is in an up-lock position.

7. The foam dispenser of claim 6, wherein said cam ramp having a lower end and an upper end and said collar defining a recess adjacent said upper end.

10 8. The foam dispenser of claim 7, wherein said collar defines a clearance slot adjacent said lower end of said cam ramp.

9. The foam dispenser of claim 6, wherein said plunger portion is movable relative to said collar wall by downward dispensing movement of said plunger when said cam rib is in alignment with said clearance slot.

15 10. The foam dispenser of claim 6 wherein said cam ramp includes an upper surface and said surface is said upper surface.

11. A dispenser for a flowable product comprising:

a container;

20 a pump mechanism constructed and arranged for dispensing said flowable product, said pump mechanism including a movable plunger which includes a first engagement member;

a collar connected to said container, said collar including a second engagement member and receiving a portion of said pump mechanism;

25 said pump mechanism being movable to an up-lock position by rotation of said first engagement member relative to said second engagement member; and

61211-2093

a seal created between a portion of said plunger and a portion of said collar when said plunger is in said up-lock position.

12. The dispenser of claim 11 wherein said second engagement member is a ramp.

13. The dispenser of claim 12 wherein said first engagement member is a follower
5 which cooperates with said ramp.

14. The dispenser of claim 13 wherein said ramp defines a recess for receipt of said follower into said up-lock position.

15. The dispenser of claim 14 wherein said collar defines a clearance spot for receipt of said follower for axial movement of said plunger for dispensing.

1/4

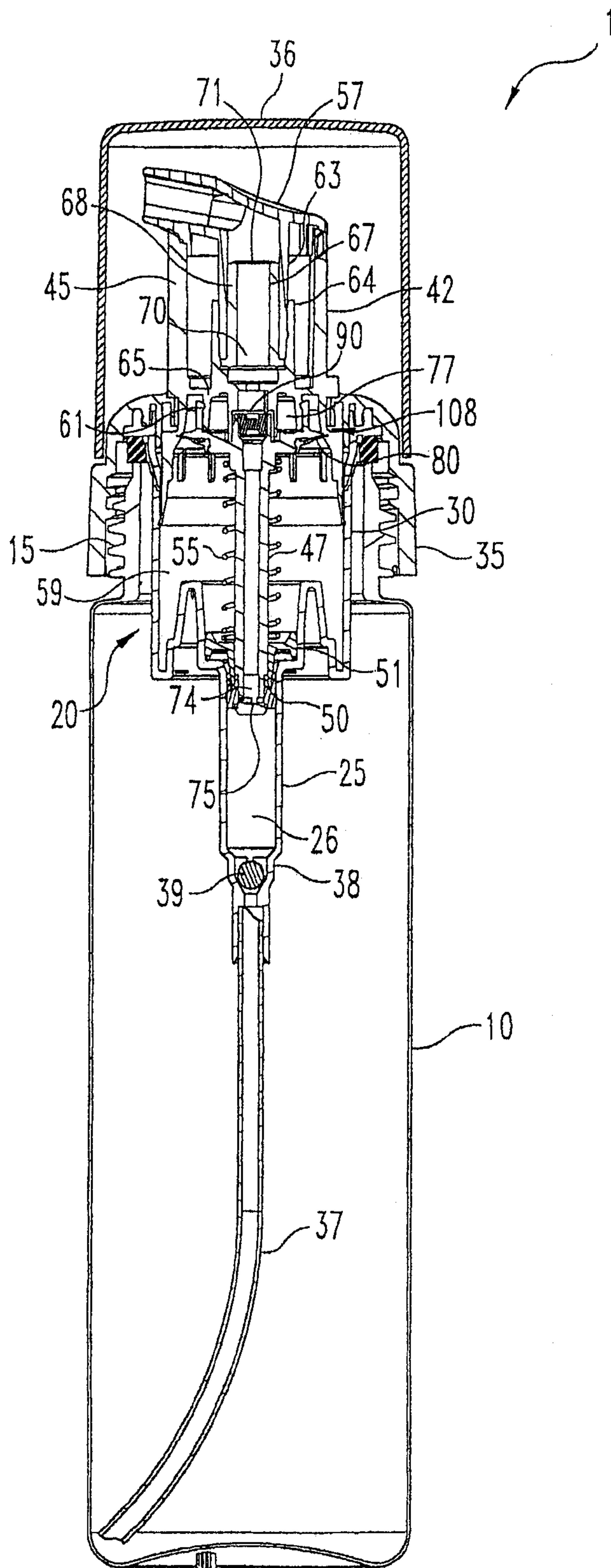

Fig. 1

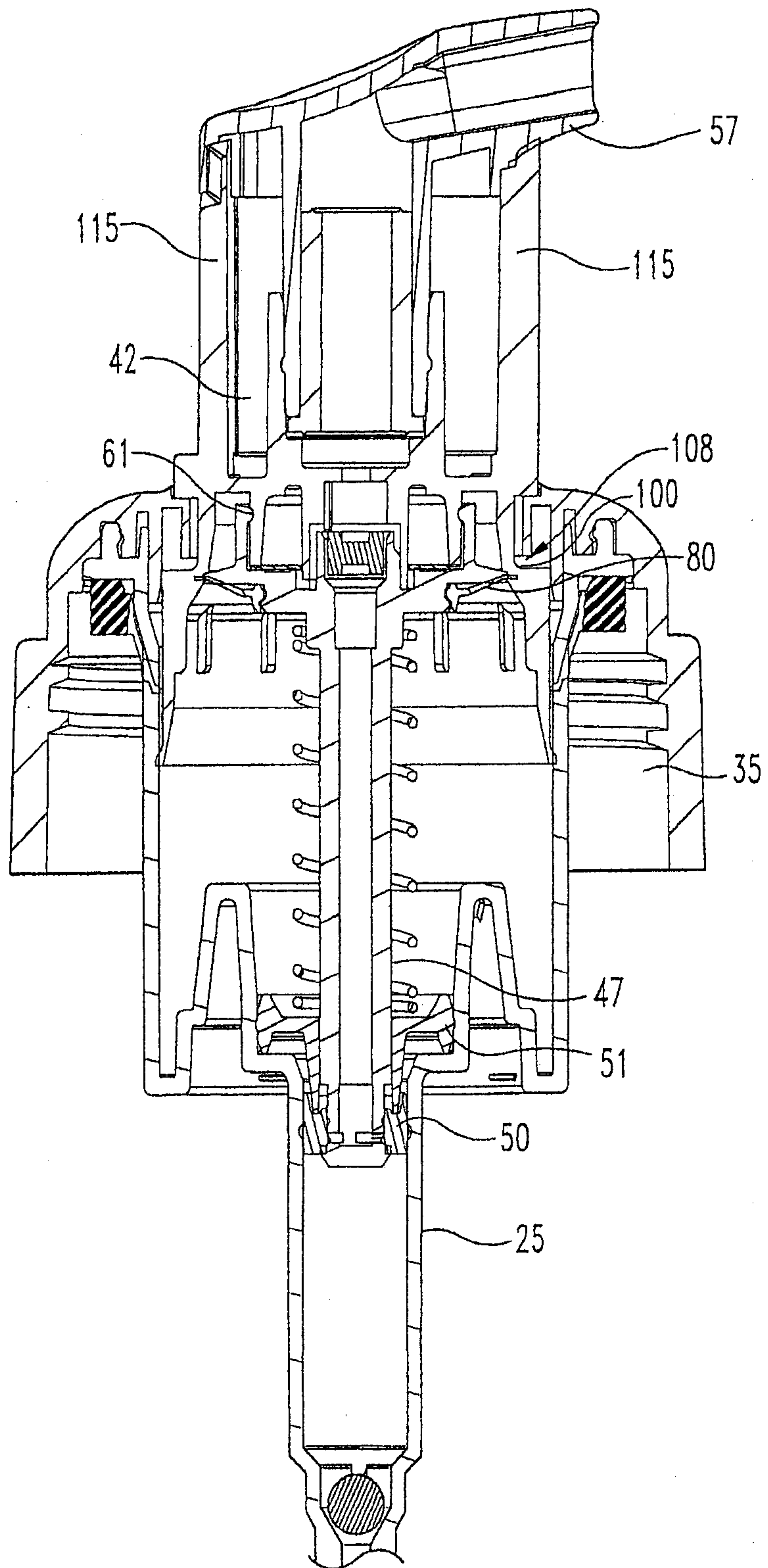

Fig. 2

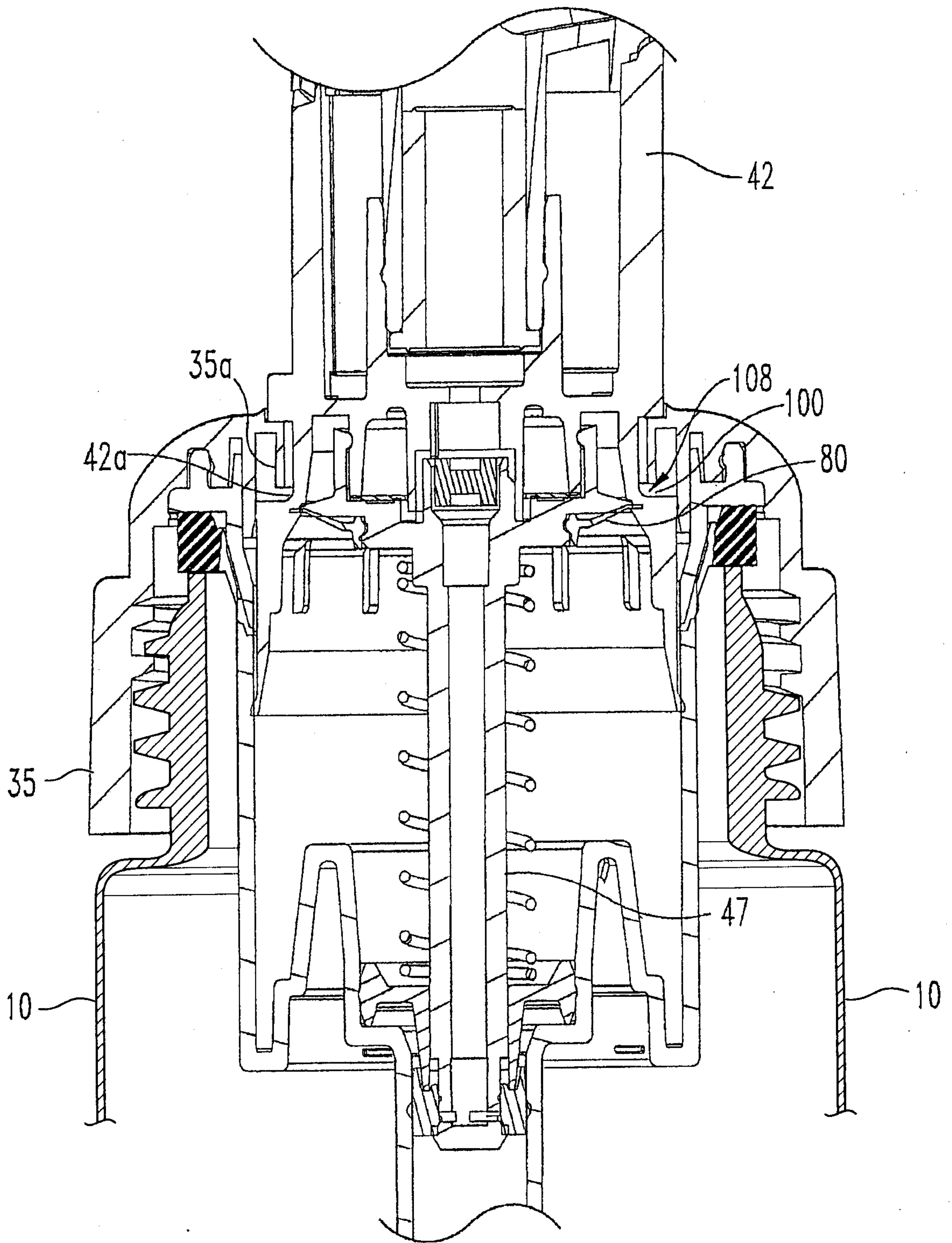

Fig. 3

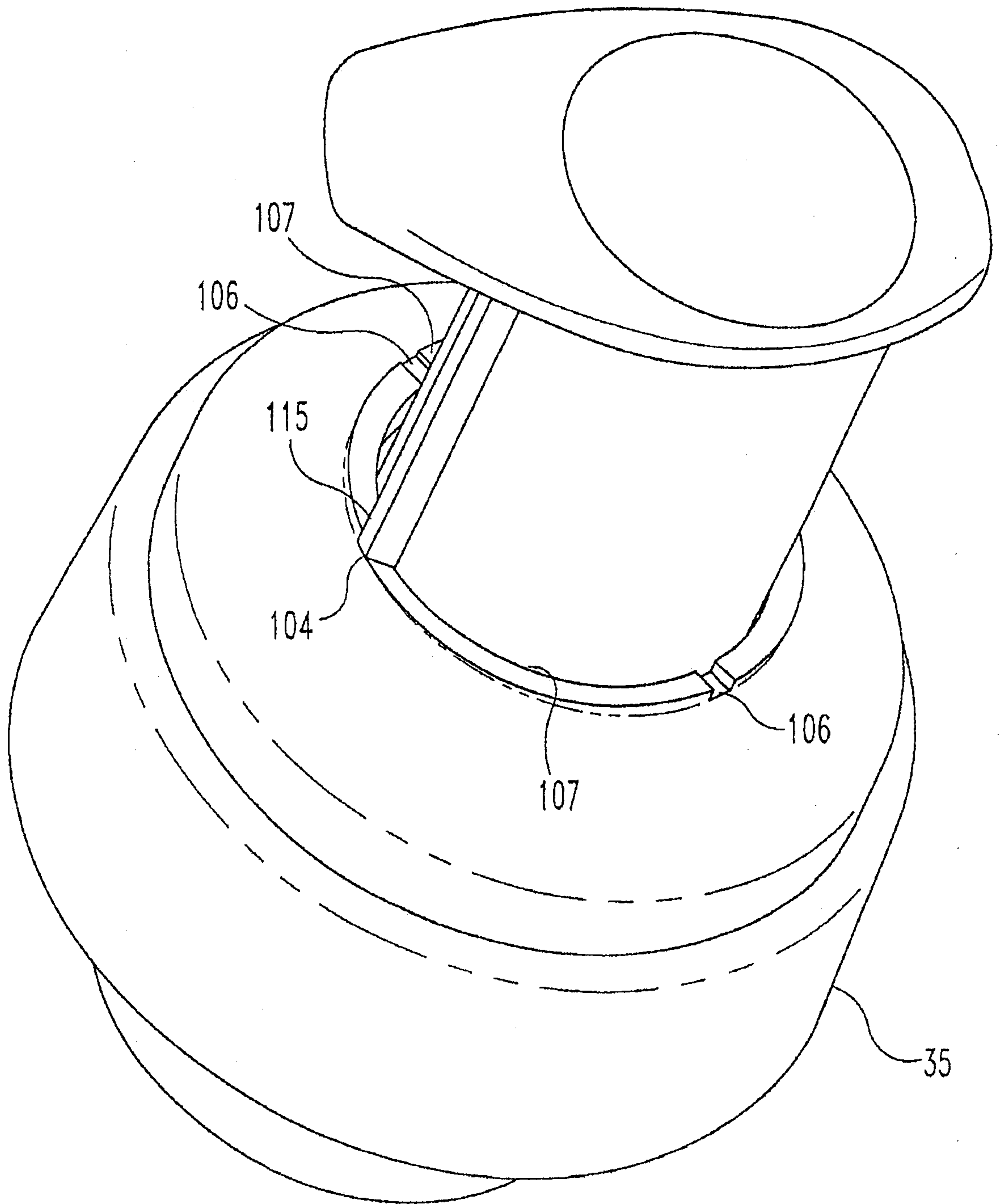

Fig. 4

