

C. C. MILLER.
Shoal Indicator for Ships.

No. 202,184.

Patented April 9, 1878.

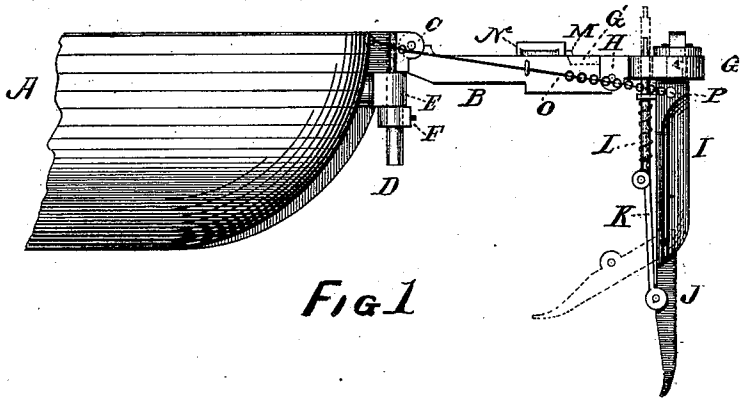

Fig 1

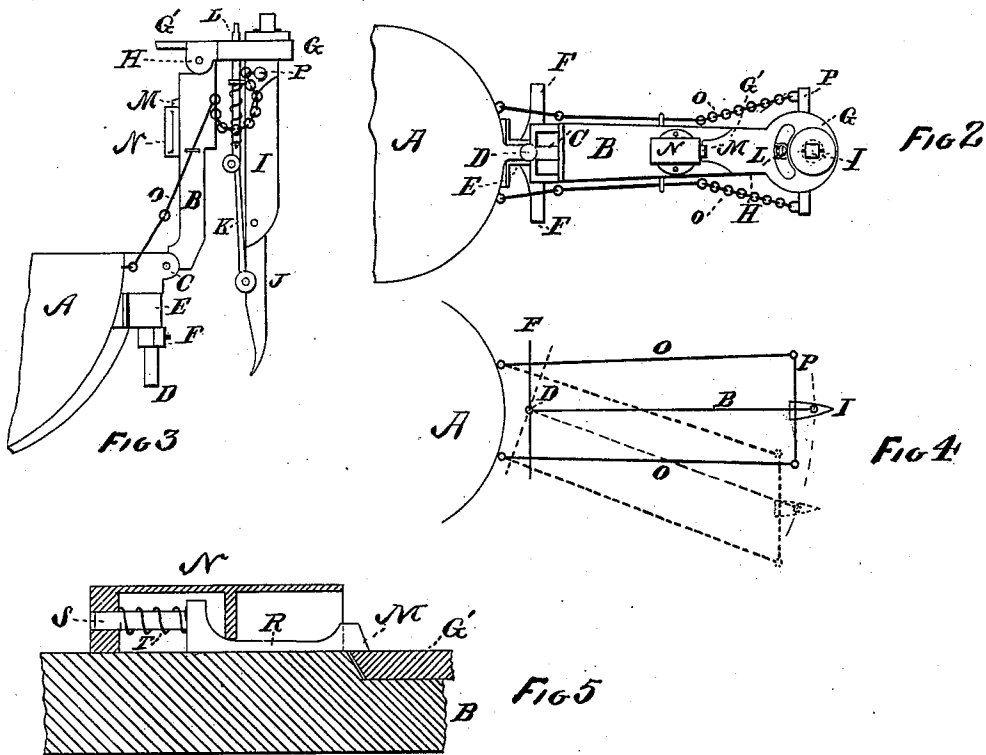

Fig 3

Fig 2

Fig 4

Fig 5

WITNESSES:
John R. Woods
Martin A. Eisele

Attorney:

INVENTOR:
Charles C. Miller
by
J. M. See

UNITED STATES PATENT OFFICE.

CHARLES C. MILLER, OF HAMILTON, OHIO, ASSIGNOR OF ONE-HALF HIS
RIGHT TO JOB E. OWENS, OF SAME PLACE.

IMPROVEMENT IN SHOAL-INDICATORS FOR SHIPS.

Specification forming part of Letters Patent No. **202,184**, dated April 9, 1878; application filed
March 7, 1878.

To all whom it may concern:

Be it known that I, CHARLES C. MILLER, of Hamilton, Butler county, Ohio, have invented a new and useful Improvement in Channel-Indicators for Boats, of which the following is a specification:

This invention relates to a device for measuring and indicating the depth of water in front of a boat; and has for its object facility in avoiding obstructions, in searching for safe channels, and in making surveys of the bottoms of rivers.

The invention consists, essentially, of an outreaching arm attached to the bow of the boat, and a yielding tracer attached to the forward end of the outreach.

The tracer touches lightly the river-bottom some distance in front of the boat, and as variations in the level of the bottom cause the tracer to rise and fall, its relative position is shown by an index above the water. This index may show at once either the exact depth of water in front of the boat, or it may show the exact depth or distance between river-bottom and keel-level, according to the manner in which the index is made to read. Furthermore, the outreach is so attached to the bow of the boat as to allow the tracer to be moved to the right or left of its normal position, by means of which sweeping motion a channel may be searched for and found, if in close proximity to the bow of the boat.

By means of this device danger becomes at once apparent, if present. The facilities for avoiding it are enhanced, thus greatly adding to the safety and speed of the navigation of shallow rivers.

A simple record of the reading of the tracer-index, together with a record of the geographical locality, furnishes at once a simple and economical method of surveying river-bottoms, being at the same time much more accurate than the usual plan of sounding at intervals with the lead.

A device for recording automatically the depth of water abaft the bow of a vessel was invented in 1876 by Echebarn and Durgess, of Brazil. It consisted of a recording-drag pulled by the vessel. In making simple bottom surveys this device may be equally as ef-

ficient as my invention; but for the purposes of shallow-water navigation it lacks all of the elements of premonitory indication which my invention so perfectly possesses. The property of being used as a feeler or searcher for deeper water is also totally lacking in the device referred to.

Another device, invented in 1858 by Bridwell, has for its object the indication of depth at the bow; but it also lacks the power of giving indications of coming danger.

In the accompanying drawings, Figure 1 is a side elevation of the bow of a boat with my channel-indicator attached. Fig. 2 is a plan of the same. Fig. 3 is a side elevation, showing the indicator when drawn up out of use. Fig. 4 is an elemental plan, which I make use of in explaining one of the qualities of the device. Fig. 5 is a section of the safety device, which guards the arrangement against accident.

The letters of reference used refer to the same parts in all of the figures.

Referring to Fig. 1 of the drawing, A is the bow of the boat, to which is attached the outreach B, whose length determines the distance forward of the bow at which the depth of water is indicated. While in use the outreach remains horizontally fixed with reference to the boat—that is, it neither rises nor falls. From the extreme forward end of the entire outreach the cut-water I reaches downward into the water, its lower end being about on a level with the bottom of the hull. The cut-water I is blade-shaped in section, as shown in Fig. 4, in order that it may offer but little resistance to the progress of the boat, and at the same time possess sufficient strength in the direction in which the boat travels.

J is the tracer, which is hinged to the lower end of the cut-water. This tracer is, like the cut-water, made blade-shaped in its general section, but is somewhat thickened and toe-shaped at its lower end, in order that it may not cut into the sand or mud over which it travels.

The length of the tracer J is governed by the character of the vessel and of the stream navigated, and is simply made to reach to the greatest depth which it is desirous to have in-

licated. A link, K, connects the tracer J with the vertical index-rod L, whose upper end, extending above the outreach, is always in plain view. The toe of the tracer J rests upon the bottom of the river, and rises and falls with each elevation or depression of the bottom. As the tracer rises it of course falls backward, swinging upon the hinge at its upper end, and its rising and falling motion will, through the medium of the link K, be converted into vertical motion of the index-rod L. The relative position of the upper end of the index-rod will thus show the position of the tracer, and consequently the depth of water in the channel. The index-rod may be graduated into inches, so that simple inspection shows at once the total depth of water, or, by proper arrangement of the zero of the index, the depth below hull. In case the index is made to show the total depth, its zero will, of course, have to be adjusted to the draft of the boat. The tracer is pressed downward by a spring upon the index-rod L, as shown, with sufficient force to prevent the tracer yielding to the resistance of the water. Obviously a weight may be substituted for the spring, to keep the tracer in contact with the river-bottom.

Only one of the properties of the arrangement has yet been explained—that of indicating the depth of water directly in front of the center of the boat.

Before proceeding to describe its other qualities of usefulness, it may be well to explain the means by which the device is guarded from accidental injury, and also the means by which it is rendered capable of being withdrawn from its normal position when out of use.

Referring still to Fig. 1, it may be mentioned that in case the boat backs while the tracer rests upon the river-bottom it would, from the nature of its shape, dig into the bottom and cause injury to the parts. The means provided for preventing this are simple, and consist in placing a hinge with a horizontal axis at the point where the outreach is attached to the bow of the boat. This hinge is marked C in the drawings, and allows the outreach to be lifted and retained in a vertical position. Furthermore, in case the tracer digs in backing, the outreach will yield at the hinge C, and allow the tracer to rise without damage. In case the precaution of elevating the outreach should be neglected as the boat approaches a bank or dock, it is evident that the cut-water I would be liable both to inflict and sustain damage. This is guarded against by placing another hinge in the outreach. This second hinge is near the forward end of the outreach, and is marked H in the drawings. This hinge is held in its ordinary state of rigidity by the spring-latch M, which will yield to extraordinary pressure applied to the cut-water, and allow the cut-water to yield and fall back. Upon the removal of the pressure the cut-water resumes its normal position.

The hinge H, it will be seen, thus forms a safety-brake in the outreach. In this connection it may be well to more fully explain the action of the spring-latch M.

That part of the outreach forward of the hinge H we may call the "head." It is marked G in the drawings. The head is provided at the hinge with a tail-piece, G', and it is this tail-piece which holds the hinge H practically rigid by reason of being held down by the spring-latch M. The spring-latch is shown on a somewhat larger scale in Fig. 5, in which G' is the tail-piece. The shank R of the spring-latch M is thin and properly flexible. Extraordinary upward pressure on the tail-piece G', produced by extraordinary pressure on the cut-water, will, of course, deflect the spring-latch and free the tail-piece G' from its detention. The tail-piece, in returning to its normal position, must displace the latch again; but it is evident that the flexibility of the shank R will not be of service in this connection. End movement of the latch is now resorted to in order to allow the tail-piece to pass it, and this end movement is accomplished by means of bevels upon the latch-face and upon the face of the tail-piece, as shown.

It is obvious that the latch will yield endwise, and allow the tail-piece to seat itself.

A spiral spring, T, returns the latch to its proper position over the tail-piece. The hinge H, in combination with the hinge C, allows the entire device to fold up when not in use, in the manner shown in Fig. 3.

The means by which the tracer is swept across the bow of the boat, feeling for a channel, will now be explained. The outreach is attached to the bow of the boat by means of the vertical pivot D, in addition to the horizontal hinge C, already referred to. To this pivot is attached the double-ended lever F, in such manner that the lever is part of the outreach, so that if the lever is swung around the outreach will swing round also.

Chains may be led from the levers F into the hull and connected with any of the usual reverse-windlass devices placed on deck; or the same chains may extend to the pilot-house, and be connected with handling mechanism placed therein. The side-sweeping motion of the outreach may be effected precisely as with rudders.

Should an increasing bar be indicated in front of the boat, the outreach is swung round to either side till the run of the bar is indicated by the index, and the better channel found.

It has been mentioned that the cut-water I was blade-shaped. As thus far described, it is obvious that when the outreach is swung from its normal position the cut-water will be presented to the water at an angle, and thus cause resistance to the boat's progress. To avoid this the cut-water is so arranged as to remain parallel with the keel of the boat without regard to the position of the outreach. This is accomplished by allowing the cut-water to rotate, with reference to the outreach, upon

a vertical axis, and providing a parallel-motion device attached to the cut-water.

The upper end of the cut-water is journaled into the head G of the outreach, and just under the head is provided with the double-ended lever P. Chains O O reach from this lever to the hull, as shown, and constitute the parallel motion, as more fully demonstrated in the elemental plan, Fig. 4, which will need no explanation, as it is obvious that the cut-water will retain a constant position with reference to the boat.

It may be added that a segmental slot in the head of the outreach suppresses all interference with the index-rod L, which would otherwise result from the rotation of the cut-water with reference to the head G.

It may be pertinent to mention that the indicating motions of the index-rod may, if desired, be converted into dial indications by mechanism well understood and in common use, and that such dial may be placed in the pilot-house, and the index motion transmitted thereto by cords or rods; or the dial may be placed conspicuously on deck, within view of the pilot.

I have not considered it necessary to elaborate herein the means by which the index-readings may be made the most convenient or refined, or the means by which the record-

paper of Echebarn and Durgess may be applied to my invention.

Self-recording mechanism has been placed in a high state of perfection, and it is simply a matter of mechanical skill to place such mechanism in connection with the index of my device.

I claim as my invention—

1. The outreach B, cut-water I, tracer J, and index L, all combined substantially as specified.
2. The outreach B, cut-water I, tracer J, index L, and hinge-joint D, all combined substantially as specified.
3. The outreach B, cut-water I, tracer J, index L, and hinge-joint C, all combined substantially as specified.
4. The outreach B, cut-water I, tracer J, index L, hinge H, and latch M, all combined substantially as specified.
5. The outreach B, cut-water I, lever P, and chains O O, all combined substantially as specified.
6. The spring-latch M, with its flexible shank R, combined with its end spring T, substantially as specified.

CHARLES C. MILLER.

Witnesses:

J. W. LEE,
W. N. GRAY.