

(No Model.)

3 Sheets—Sheet 1.

G. G. WOLFE.
HOT AIR FURNACE.

No. 378,061.

Patented Feb. 14, 1888.

FIG. 1

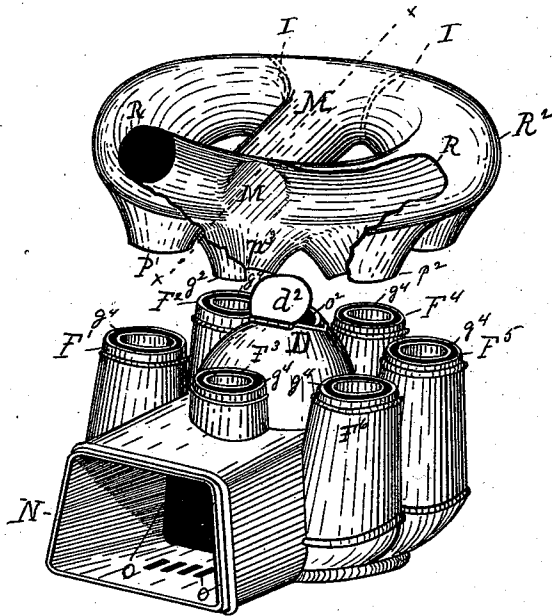
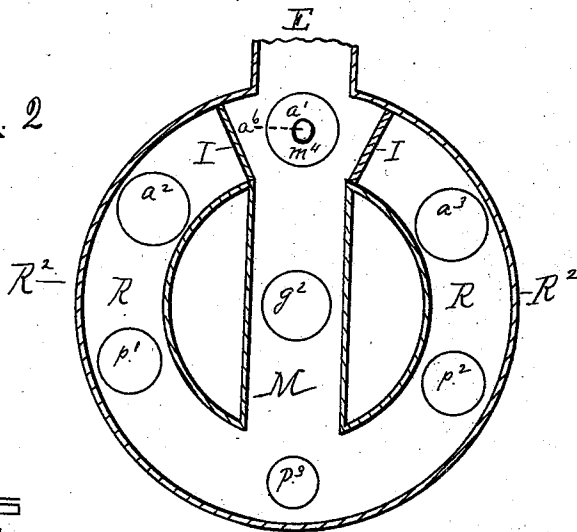

FIG. 2



WITNESSES

Geo. A. Garby

Charles S. Brintnall

INVENTOR

Guadon G. Wolfe.

By W. B. Hagan, his
att'y

(No Model.)

3 Sheets—Sheet 2.

G. G. WOLFE.
HOT AIR FURNACE.

No. 378,061.

Patented Feb. 14, 1888.

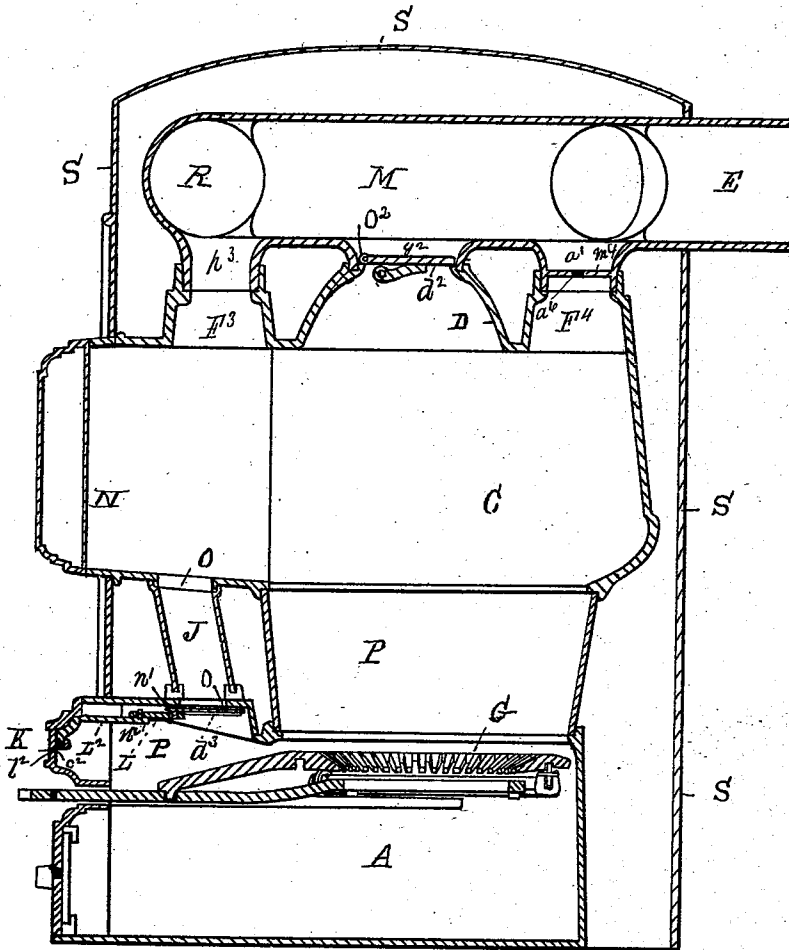

Fig. 3

WITNESSES:

Geo. A. Darby
Charles S. Brintnall

INVENTOR

Guidon G. Wolfe,
by W. C. Hagan, his atty.

(No Model.)

3 Sheets—Sheet 3.

G. G. WOLFE.
HOT AIR FURNACE.

No. 378,061.

Patented Feb. 14, 1888.

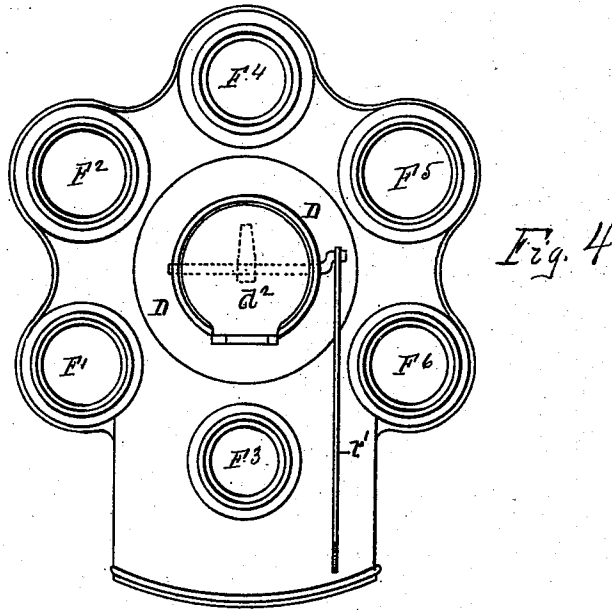

Fig. 4

Fig. 7

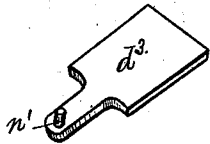

Fig. 5

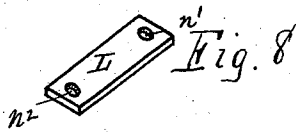
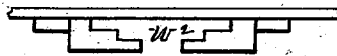

Fig. 8

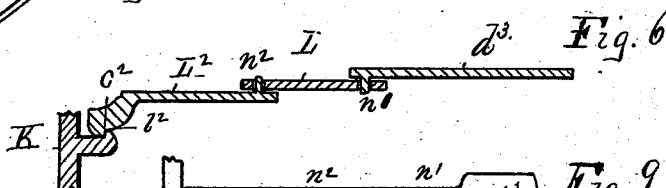

Fig. 6

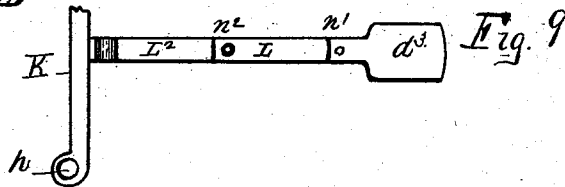

Fig. 9

WITNESSES:

Geo. A. Darby
Charles S. Brintnall.

INVENTOR

Gordon G. Wolfe
by W. C. Kagan his atty

UNITED STATES PATENT OFFICE.

GURDON G. WOLFE, OF TROY, NEW YORK, ASSIGNOR TO THE FULLER & WARREN COMPANY, OF SAME PLACE.

HOT-AIR FURNACE.

SPECIFICATION forming part of Letters Patent No. 378,061, dated February 14, 1888.

Application filed October 28, 1886. Serial No. 217,483. (No model.)

To all whom it may concern:

Be it known that I, GURDON G. WOLFE, of the city of Troy, county of Rensselaer, State of New York, have invented new and useful Improvements in Hot-Air Furnaces, of which the following is a specification.

My invention relates to improvements in hot-air furnaces; and these improvements have for their object the better and more uniform distribution to the radiating-flues of the heat evolved from the fire-pot by an improved construction of said flues as to their comparative size and relative arrangement with reference to the exit-pipe, and the production by construction of a novel and efficient means to prevent the dust and ashes thrown out of the furnace from escaping into the room while the grate is being cleared of ashes and clinker, and in the construction and novel arrangement of parts to produce a direct draft from the fire pot or cylinder to the exit.

As the radiating-flues of hot-air furnaces are usually made, they are constructed to all have the same transverse area as to size and capacity, and as thus made those of them which furnish the most direct passage for the heated products of the fire to the exit-pipe carry off a larger part of the heat, while those most remote from the exit receive and radiate to the passing air much less of the heat, which unequal distribution of the latter renders the action of the furnace irregular, it being a well-known law that the heat generated by the fire in a hot-air furnace and under the draft impulse of a chimney will take the most direct course to the exit; and to remedy this difficulty by an improved means of construction and arrangement of the flues with reference to the latter is one of the purposes of my invention.

Accompanying this specification, to form a part of it, there are three sheets of drawings, containing nine figures, illustrating my invention, with the same designation of parts by letter-reference used in all of them.

Of these illustrations, Figure 1 is a perspective of the combustion-chamber top, its dome, and upcast vertical flue parts, showing, also, as separated from the latter a ring-form top flue having a connected cross-flue and depending vertical flue parts that connect with the

vertical flue parts of the combustion-chamber, but in this illustration being shown as pulled apart from their connection, and with part of the ring-form flue shown as broken out. Fig. 2 shows a central transverse sectional view of the ring-form top flue and its diametrically-arranged cross-flue and exit. Fig. 3 is a central vertical section of my improved furnace, taken from front to rear, with one-half of the fire-grate shown in side elevation. Fig. 4 is a top view of the vertical flue parts and dome, illustrating, also, a means for operating a direct draft from the fire-pot to the top flue by means of a damper arranged in an opening in the dome-top. Fig. 5 is a front elevation of a guide-plate in which the dust-damper and its connections move. Fig. 6 is a longitudinal vertical section taken through the dust-damper, its link-plate, latch-plate, and the latch on the door of the clinker-cleaning opening or passage, by which door as it is opened or closed the dust-damper is operated. Fig. 7 is a perspective view of the dust-damper. Fig. 8 shows as detached the link-plate that connects the dust-damper with the latch-plate. Fig. 9 is a top view of the dust-damper, its connections, and the hinged door of the clinker-cleaning passage.

The several parts of the hot-air furnace thus illustrated, as well as those containing my invention, are designated by reference-letters, and the function of the parts is described as follows:

The letter S designates the exterior shell of the furnace; A, the ash-pit; G, the fire-grate; P, the fire-pot or fire-cylinder, and C the combustion-chamber.

The letter D indicates the dome formed in the top of the combustion-chamber, and N the fuel-supply or feed-passage leading from the furnace exterior to the combustion-chamber.

The letter R designates a ring-form top-flue, having connected with it interiorly and downwardly extended therefrom the flue parts $p^1 p^2$ and $a^1 a^2 a^3$, adapted to connect with the upcast flue parts of the combustion-chamber, and to thus form vertical flues leading from said combustion-chamber to said ring-form flue R.

The letter M designates a cross-flue that is

arranged diametrically with reference to the ring-form flue, and at one of its ends this cross-flue connects interiorly with the latter and at its other end it is continued through said ring-form flue to produce the exit E by means of the interiorly-placed vertical partition-plates I I, that are arranged to close up the ring-form flue thereat, and leaving an intervening area between said plate and within the ring R², so as to make a continuation of the cross-flue M leading to the exit.

The letter *g*² designates a flue that is formed on and connects with the cross-flue M from the under side of the latter, and is made to extend downwardly to connect with the top of the dome D by means of an opening, O², made in the top of the dome.

The letter *d*² designates a damper that is arranged in the flue *g*², and this damper is constructed with a damper-rod, *r*², which passes exteriorly to the front. When this damper *d*² is closed, the heated products coming from the fire are caused to pass indirectly to the exit through the ring-form flue R to the cross-flue M and to the exit; but when this damper is opened, then the heated gases from the fire pass directly to the cross-flue, and thence to the exit.

The letter *a*² designates a flue part that is extended downwardly from that part of the flue-ring R² which incloses the ring-form flue R where the continuation of the flue M is made in the ring R. At its upper end this flue part *a*² opens into the flue M, and at its lower end it is adapted to connect with any of the flue parts that are upcast from the combustion-chamber. The flue parts *p*² *p*² *p*², that are down-cast from the horizontal ring-form flue R, are arranged on the under side of that diametrical half of the latter which is opposite to that wherefrom the continuation of the flue M emerges to produce the exit E, but which is nearest to the connection made between the said ring-form flue and the cross-flue whereon the exit is formed, so that the heat passing through said flue parts *p*² *p*² *p*² has but a short distance to move before it reaches the exit E. The transverse flue-area of each of these flue parts *p*² *p*² *p*² is made smaller than the flue-areas of the flue parts *a*² *a*², for the purpose of reducing the area of flue-passage of such of the flue parts as have the most direct and shortest passage to the exit, and making larger comparatively those flue-areas from which the passing heat has the longest and most indirect passage to the exit. The flue part *a*² being arranged in that part of the ring R² which forms the continuation of the cross-flue M, and which at its upper end connects with the latter, is made with a diaphragm-plate, *m*², having the small flue-passage *a*². This diaphragm-plate *m*², with the small flue-passage *a*², gives to the flue *a*² a smaller area than those flues which are farther from the line of direct draft, and operates to equalize and distribute the drafts in the direction of the other flues. The combustion-cham-

ber C is roofed in by the dome D and the upwardly-projected and inwardly-tapering flue parts F² F² F² F² F² F². These flue parts connect at their upper ends with the pendent flue parts formed on the ring R², and indicated at *p*² *p*² *p*² and *a*² *a*² *a*², wherever the said flue parts come vertically opposite. The upcast flue parts of the combustion-chamber all have the same transverse area at their upper ends, and each of them thereat is made with an annular groove, *g*², that is adapted to receive and make a gas-tight joint with the lower end of any one of the downcast flue parts of the ring-form flue R. As thus constructed and arranged the ring-form flue R has a series of radial points at which its downcast flue parts may connect with the upcast flue parts of the combustion-chamber, and so as to bring the exit E at such a point as may be most convenient for connection with the chimney; but at whatever point the ring-form flue may connect with the combustion-chamber the contracted flue parts *a*², *a*², and *a*² will be in that diametrical half of said ring-form flue that furnishes the shortest and most direct passage of the heat to the exit-flue, and which by their location and contracted area will compel a proper portion of the heat to pass through the larger vertical flue parts which are in that part of the ring-form flue where the heat has the greatest distance to move to the exit, and thus to make the action of the furnace uniform thereby.

The letter J indicates a dust-flue connecting by means of an opening, O, in the bottom of and with the feed-passage N at its upper end, and at its lower end with the clinker-cleaning area P.

The letter *d*² indicates a dust-damper constructed at the bottom of said flue and arranged to automatically open or close said dust-flue by means of latch-connection made between said damper and the door of the clinker-cleaning passage. When the clinker-cleaning door is opened for the purpose of cleaning the clinker from the grate, the door in opening draws out the damper of the dust-flue to open the latter, and so that there is a draft-passage from the clinker-cleaning area directly to the fire-pot above the fire, and when the door K is closed then the damper *d*² closes up the bottom of the dust-flue.

The letter L designates a flat link-plate which at its inner end, at *n*², is pivotally connected to the damper-plate *d*² and at its outer end pivoted to the latch-plate L² at *n*², and the letter *l*² indicates a lip formed on the under side and outer end of the latch-plate. The door K of the clinker-cleaning passage or area is constructed on its inner face with a catch, *c*², adapted to engage with the lip *l*² of the latch-plate.

The dust-damper and its connection with the clinker-cleaning door are operated as follows: When the door is closed, then the latch and catch connect. When the door is opened,

the catch therein draws out the damper until in its hinged movement at h , as turning, the door, after having drawn out the damper, disengages the latch. When the door is closed, the catch on the latter underruns the lip l^2 on the latch-plate, and by the contact of the latter with the inner face of the door K the damper is forced to close.

The letter W indicates a guide-plate which is arranged across the clinker-cleaning passage P, and this plate is provided with a guide-way, w^2 , for the transverse passage of the damper-plate and link-plate.

Having thus described my invention, what I claim, and desire to secure by Letters Patent, is—

1. In a hot-air furnace, the combination of a combustion-chamber provided with upcast vertical flue parts, a ring-form horizontal flue formed with downcast flue parts to connect with the flue parts of the combustion-chamber and having a transversely-cross exit-flue opening at one end into the said ring-form flue and at the other end passing through said ring-form flue, and a flue part, a' , projecting downward from the cross exit-flue at its passage through the ring-form flue to connect with

an upcast flue on the combustion-chamber, and provided with a diaphragm arranged therein formed with an aperture, a^2 , whereby the area of the flue a' is made smaller than the respective areas of those flues which are farther from the line of direct draft, substantially as described.

2. The combination, in a hot-air furnace, of a dust-flue connecting with the bottom of the fuel-supply passage at its upper end and at its lower end with the clinker-cleaning area of the furnace, a damper arranged transversely in said dust-flue, a link-plate connected to said damper, a latch-plate made with a latch at its outer end and at its inner end connected to said link-plate, and a latch-catch arranged on the inner face of the hinged door of the clinker-cleaning area, adapted to engage with said latch, substantially in the manner as and for the purposes set forth.

Signed at Troy, New York, this 10th day of July, 1886, and in the presence of the two witnesses whose names are hereto written.

GURDON G. WOLFE.

Witnesses:

ROBERT S. WOOD,
HORACE F. BOARDMAN.