

Dec. 6, 1938.

J. E. KAUFFMAN

2,139,308

CUFF FASTENER

Filed March 17, 1938

Fig. 1.

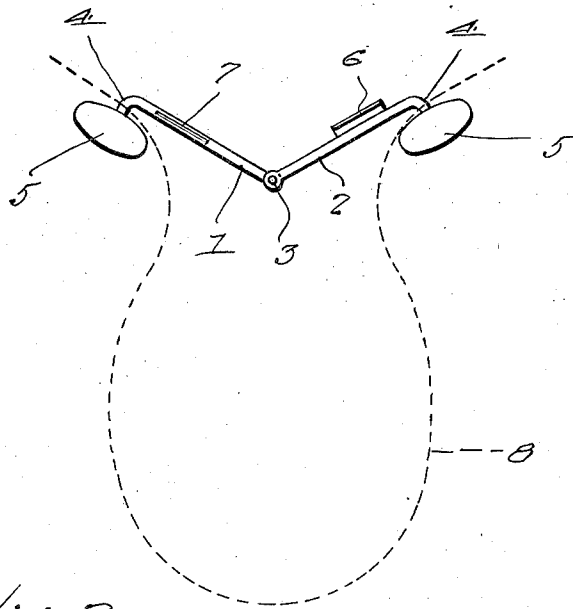

Fig. 2.

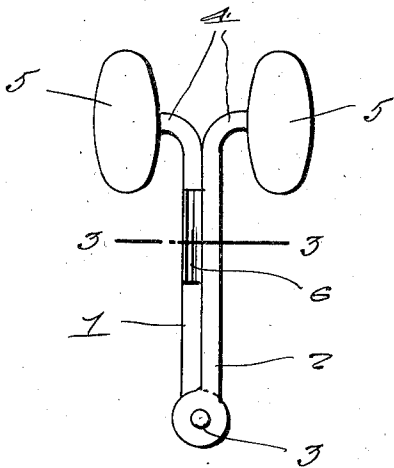
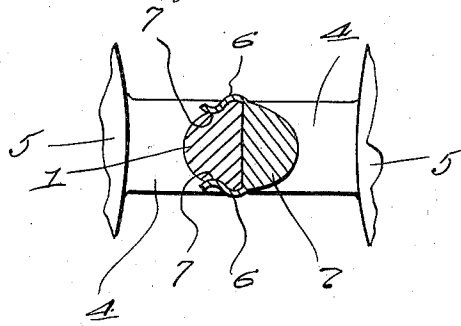

Fig. 3.



Inventor

J. E. Kauffman

By *Clarence A. O'Brien*
and Hyman Berman
Attorneys

UNITED STATES PATENT OFFICE

2,139,308

CUFF FASTENER

Jacob E. Kauffman, Daytona Beach, Fla., assignor
of one-fourth to Philip E. Cobden and one-
fourth to Frank E. Newlin, both of Daytona
Beach, Fla.

Application March 17, 1938, Serial No. 196,551

1 Claim. (Cl. 24—102)

The present invention relates to new and useful improvements in cuff fasteners and has for its primary object to provide, in a manner as hereinafter set forth, an article of this character which may be conveniently expanded when desired to permit the cuff to open for the passage of the hand therethrough, thus allowing insertion of the fastener before the shirt is put on.

Another very important object of the invention is to provide a cuff fastener embodying novel means for releasably securing the device in closed position.

Other objects of the invention are to provide a cuff fastener of the character described which will be comparatively simple in construction, strong, durable, highly efficient and reliable in use, compact, attractive in appearance and which may be manufactured at low cost.

All of the foregoing and still further objects and advantages of the invention will become apparent from a study of the following specification, taken in connection with the accompanying drawing wherein like characters of reference designate corresponding parts throughout the several views, and wherein:

Figure 1 is an elevational view, showing an embodiment of the invention in open or extended position.

Figure 2 is an elevational view, showing the fastener closed.

Figure 3 is a cross sectional view, taken substantially on the line 3—3 of Fig. 2.

Referring now to the drawing in detail, it will be seen that the embodiment of the invention which has been illustrated comprises shanks 1 and 2 of suitable metal. The shanks 1 and 2 are hingedly connected at one end, as at 3. As shown to advantage in Fig. 2 of the drawing, the shanks 1 and 2 terminate in substantially right angularly projecting free end portions 4 having fixed thereon heads 5.

Fixed at an intermediate point on the shank 2 is a pair of resilient jaws 6 adapted to receive the shank 1 therebetween. The side portions of

the shank 1 are provided with recesses or grooves 7 in which the resilient jaws 6 engage.

It is thought that the operation of the fastener will be readily apparent from a consideration of the foregoing. The heads 5 of the article are inserted through the usual button holes in the cuff. The shanks 1 and 2 are then swung to substantially the position shown in Fig. 1 of the drawing in order that the cuff may readily open to facilitate the passage of the hand there-through. After the hand has been slipped through the cuff the shanks 1 and 2 are swung to closed position, as seen in Fig. 2 of the drawing, and the resilient jaws 6 snap into the grooves 7 for securing the article in closed position. Of course, when it is desired to remove the shirt, the fastener is again opened to permit the cuff to be slipped over the hand. The jaws 6 releasably secure the hingedly connected shanks 1 and 2 in parallelism with each other with the exception, of course, of the oppositely projecting end portions 4 thereof.

It is believed that the many advantages of a cuff fastener constructed in accordance with the present invention will be readily understood and although a preferred embodiment of the device is as illustrated and described, it is to be understood that changes in the details of construction may be resorted to which will fall within the scope of the invention as claimed.

What is claimed is:—

A cuff fastener of the class described comprising a pair of metallic shanks hingedly connected at one end, the free end portions of said shanks extending at substantially right angles, heads fixed on the free ends of the shanks, one of the shanks having longitudinal grooves therein at an intermediate point, and resilient jaws on the other shank at an intermediate point adapted to receive said one shank therebetween and engageable in the grooves for releasably securing the shanks against swinging movement relative to each other.

JACOB E. KAUFFMAN.