

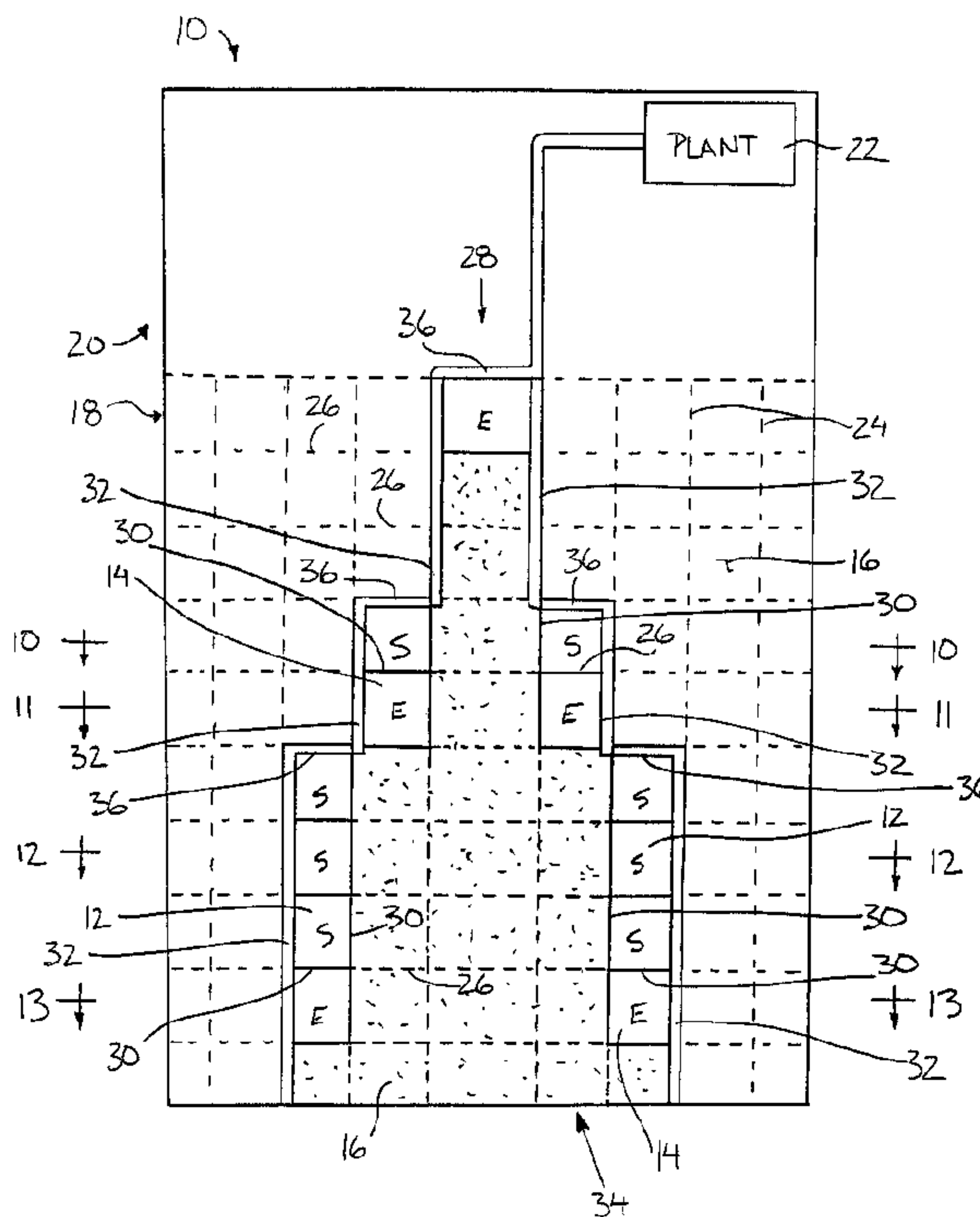

(22) Date de dépôt/Filing Date: 2001/11/09
(41) Mise à la disp. pub./Open to Public Insp.: 2002/04/14

(51) Cl.Int.⁷/Int.Cl.⁷ E21C 47/10
(71) Demandeur/Applicant:
WAKSHINSKY BROS. LTD., CA
(72) Inventeurs/Inventors:
WAKSHINSKY, EDWARD J., CA;
WAKSHINSKY, KENNETH M., CA
(74) Agent: ADE & COMPANY

(54) Titre : METHODE D'EXPLOITATION D'UNE CARRIERE
(54) Title: METHOD OF OPERATING A QUARRY AREA



(57) Abrégé/Abstract:

A method is provided for operating a quarry area having a layer of rock covered by a layer of overburden. The area is first divided into a plurality of strips with overburden from a selected first strip being stripped by depositing the overburden adjacent respective sides of the strip. The layer of rock from the first strip is stripped, blasted and excavated in sections for minimising the collection of water within a given work area. When stripping sections of adjacent strips, the overburden is deposited in the previously excavated strip or previously excavated section of the strip in a manner so as to cover an open rock face of the stripped section before blasting. Covering the rock face contains the rock to be blasted within a given section of the quarry area. Excavating equipment is supported above the rock layer for working below the water table if required. Depositing overburden in previously excavated strips and sections minimises displacement of overburden about the quarry area while maximising the accessible rock of the quarry area.

ABSTRACT

A method is provided for operating a quarry area having a layer of rock covered by a layer of overburden. The area is first divided into a plurality of strips with overburden from a selected first strip being stripped by depositing the overburden adjacent respective sides of the strip. The layer of rock from the first strip is stripped, blasted and excavated in sections for minimising the collection of water within a given work area. When stripping sections of adjacent strips, the overburden is deposited in the previously excavated strip or previously excavated section of the strip in a manner so as to cover an open rock face of the stripped section before blasting. Covering the rock face contains the rock to be blasted within a given section of the quarry area. Excavating equipment is supported above the rock layer for working below the water table if required. Depositing overburden in previously excavated strips and sections minimises displacement of overburden about the quarry area while maximising the accessible rock of the quarry area.

METHOD OF OPERATING A QUARRY AREA

FIELD OF THE INVENTION

The present invention relates to a method of operating a quarry area and more particularly to a method of handling overburden in a quarry area being
5 excavated.

BACKGROUND

When excavating a layer of rock in a quarry area, the layer of rock is commonly covered with a layer of soil referred to as overburden. Before excavation of the rock is permitted, the overburden must first be stripped to expose the rock for
10 access with excavating equipment. Managing the overburden typically involves forming a large pile in a centrally located portion of a given quarry area which has already been excavated. Excavating equipment operates on a floor of the quarry area where overburden has been stripped and the layer of rock has already been excavated. Excavation of the rock typically involves blasting an open face of the
15 layer of rock which has already been stripped. Managing the overburden in this manner involves considerable time and expense for transporting the overburden to the centrally located portion of the area as well as requiring excavating equipment to operate on the floor of the quarry area so as to be unsuitable when the floor below the layer of rock is below the water table level of that area. Furthermore working
20 with an open rock face causes the rock to be thrown from the open face during blasting, possibly causing damage to quarry equipment and making it difficult to collect the blasted rock, known as muck, which may be strewn about the area.

United States patent 4,135,762 to Biancale provides a quarry operation which proposes to solve some of the above noted problems. The quarry operation
25 involves stripping overburden from a first strip of the quarry area by piling the overburden of that strip along respective sides of the strip. Once the strip has been

- 2 -

excavated of rock, the stripped overburden as well as overburden from adjacent strips of the area are piled in the trench formed by excavation of the first strip. Overburden is piled in the trench in a manner so as to maintain an open rock face along both sides of the trench for blasting the open rock face in the conventional manner. When blasting in this arrangement, the muck is strewn about the pile of overburden within the trench making it awkward and time consuming to collect the muck. Furthermore Biancale illustrates excavating an entire strip at one time before proceeding with stripping of the next strip of the area so as to expose large areas of the floor of the quarry area at any given time which is easily flooded when working below the water table. Formation of small dikes would be required to clear a working area of water in this arrangement when working below the water table.

SUMMARY

According to the present invention there is provided a method of operating a quarry area having a layer of rock covered by a layer of overburden, the method comprising:

- a) dividing the area into a plurality of strips;
- b) stripping overburden from a selected first strip of the plurality of strips;
- c) blasting and excavating the layer of rock from the first strip;
- d) stripping overburden from a next strip adjacent the strip previously excavated;
- e) depositing overburden from the next strip within the strip previously excavated;
- f) covering an open rock face of the next strip adjacent the strip previously excavated with overburden;
- g) blasting and excavating the layer of rock from the next strip; and

- 3 -

h) repeating steps d) through g).

The steps d) through g) may be repeated on both sides of the first strip until the area is completely excavated.

By covering the open rock face before blasting a given strip or a given
5 section of the strip, the muck is contained within a small portion of the quarry area
for ease of collection. A given section which has been excavated in this
arrangement is able to contain more overburden therein as the overburden can be
piled up against respective sides of the section where the open rock face is to be
covered. The stripping of overburden in this arrangement is also less costly and less
10 time consuming as the overburden can be pushed over the edge of the open rock
face a relatively short distance using simple earth moving equipment in place of
back hoes and the like. Furthermore, each given excavation section or strip is
enclosed and separated from adjacent sections or strips by the overburden covering
the open rock face of the area to be excavated for simplifying the task of removing
15 any water if required when working below the water table.

The method preferably includes starting stripping overburden from the
next strip before the strip previously excavated has been completely blasted and
excavated. In addition, the method may include starting stripping the next strip
before the strip previously excavated has been completely stripped but after the strip
20 previously excavated has been at least partly excavated.

A path of stripped rock is preferably reserved alongside each strip after
stripping which remains unblasted and unexcavated until the next strip adjacent the
path of rock is blasted and excavated upon which another path of rock is reserved
alongside that next strip for defining a road on a surface of the rock layer. Rock
25 excavated from each strip may then be transported along the respective road
defined alongside that strip using suitable trucks for transporting the rock to a

- 4 -

processing plant.

When excavating, excavating equipment is preferably supported on an upper surface of the rock layer above a water table of the area for excavating rock below the water table.

5 The open rock face of the next strip is preferably covered by pushing the overburden of the next strip over a side edge of the next strip adjacent the strip previously excavated which defines the open rock face using suitable earth moving equipment until the rock face is sufficiently covered so as to contain rock within the next strip when the next strip is blasted.

10 Stripping, blasting and excavating each strip may be performed in sections starting with a first section adjacent one end of the strip. The method in this instance preferably includes piling overburden from the first section of the first strip above the overburden surrounding the first section.

15 After stripping, blasting and excavating the first section of the strip, the method preferably includes the following steps:

i) stripping overburden from the next section adjacent the section previously excavated;

j) depositing overburden from the next section within the section previously excavated;

20 k) covering an open rock face of the next section adjacent the section previously excavated;

l) blasting and excavating the layer of rock from the next section; and

m) repeating steps i) through l) until the strip is completely excavated.

25 A floor of each section is preferably covered immediately after the section is excavated with overburden stripped from a next section adjacent that section.

- 5 -

The width of each strip is preferably substantially constant over a full length of the strip with the first strip being wider than the remaining strips. When stripping the next strip, overburden is removed so as to make the strip wider until sufficient overburden is stripped from the next strip that the open rock face is covered in a manner so as to contain rock within the next strip when the next strip is blasted.

In one arrangement, only a portion of the area might be divided into a plurality of strips for locating a processing plant for excavated rock on a remaining portion of the area so that the plant does not require frequent relocation during excavation of the area.

According to a second aspect of the present invention there is provided a method of operating a quarry area having a layer of rock covered by a layer of overburden, the method comprising:

- a) dividing the area into a plurality of strips and dividing each strip into a plurality of sections;
- b) stripping overburden from a first section at one end of a selected first strip of the plurality of strips;
- c) blasting and excavating the layer of rock from the first section;
- d) stripping overburden from a next section of the strip adjacent the section previously excavated;
- e) covering an open rock face of the next section adjacent the section previously excavated with overburden;
- f) blasting and excavating the layer of rock from the next section; and
- g) repeating steps d) through f) until the strip is excavated.

The method preferably includes piling overburden from the first section above the overburden surrounding the first section. The stripped overburden from

- 6 -

each subsequent section is preferably deposited within the section previously excavated adjacent thereto.

BRIEF DESCRIPTION OF THE DRAWINGS

In the accompanying drawings, which illustrate an exemplary
5 embodiment of the present invention:

Figure 1 is a top plan view of a first section of a first strip to be stripped of overburden of the quarry area.

Figure 2 is a sectional view along the line 2-2 of Figure 1.

Figure 3 is a top plan view of the section of Figure 1 after excavation of
10 the rock from that section.

Figure 4 is a sectional view along the line 4-4 of Figure 3.

Figure 5 is a top plan view of the section of Figure 1 after being partly filled by the overburden of an adjacent section.

Figures 6 and 7 are sectional views along the line 6-6 of Figure 5,
15 before and after excavation of the adjacent section respectively.

Figure 8 is a top plan view of the first section of the first strip of the quarry after several adjacent sections have been stripped of overburden or excavated.

Figure 9 is a top plan view of the quarry area after several sections of
20 plural strips of the area have been stripped of overburden or excavated.

Figure 10 is a sectional view along the line 10-10 of Figure 9.

Figure 11 is a sectional view along the line 11-11 of Figure 9.

Figure 12 is a sectional view along the line 12-12 of Figure 9.

Figure 13 is a sectional view along the line 13-13 of Figure 9.

25 DETAILED DESCRIPTION

Referring to the accompanying drawings, there is illustrated a quarry

- 7 -

area generally indicated by reference numeral 10. The area generally includes a layer of rock 12 in the form of white limestone to be excavated which is supported above a floor 14 typically of red or grey limestone. The layer of rock 12 is covered with varying amounts of overburden 16 which must be removed before excavating the layer of rock 12. In some instances the floor 14 lies below the water table level of the quarry area 10.

Traditionally, a quarry area 10 is selected which has minimal overburden 16 so that the layer of rock 12 is close to the surface of the ground and lies mostly above the water table level of the area so that equipment may be supported directly on the floor 14. As these preferred sites become excavated, it is now more common to encounter thicker overburden 16 and a layer of rock 12 which may be partly submerged below the water table as more desirable sites become depleted and less desirable areas are now being exploited. In one example of an area which might now be exploited, one may expect a layer twenty to twenty-five feet thick of white limestone covered by up to twenty feet of overburden with the water table level possibly being in the order of several feet above the floor upon which the layer of white limestone sits.

A method of operating the quarry area 10 begins by first dividing the area into an excavating portion 18 and a processing portion 20. A processing plant 22 may then be located on the processing portion 20 of the area remotely from the portion of the area being actively excavated. The processing plant 22 is provided for crushing the muck collected from the area and for sorting the crushed rock according to size for subsequent distribution.

Excavation of the excavating portion 18 begins by first dividing the portion into a plurality of strips 24 which are subsequently divided into a plurality of sections 26. A selected first strip 28 is centrally located so that excavation may

- 8 -

begin centrally within the area 10 at one end thereof opposite the plane 22..

The process begins by stripping overburden from the strips 24 in sections to permit the layer of rock 12 beneath the overburden to be blasted and excavated in sections following stripping. Stripping, blasting and excavation of adjacent strips 24 on both sides of the selected first strip 28 proceeds until the excavating portion 18 is completely excavated. The plant 22 may then be relocated for excavating the remaining portion of the quarry 10.

Stripping of the next strips adjacent to the selected first strip begins before the first strip is completely stripped, blasted or excavated but after the first strip is at least partially excavated so that overburden from the adjacent strips 24 may be deposited into the previously excavated strip. Alternatively, when stripping overburden from each strip 24 in sections, the overburden from one section may be deposited in a previously excavated section adjacent thereto. In either arrangement or any combination thereof, the open rock face 30 of any given strip or section adjacent to a previously excavated strip or section, is covered with overburden for containing muck within the next section when blasting and excavating the muck.

The width of the selected first strip 28 is typically bigger than the remaining strips 24 with the width of any given strip being substantially constant over the length of that strip. When stripping overburden from a subsequent strip 24 adjacent a previously excavated strip, the width of the subsequent strip depends on the thickness of overburden of that strip as the strip will be made wider until sufficient overburden is stripped therefrom that the open rock face adjacent the strip previously excavated may be sufficiently covered to contain rock within the subsequent strip during blasting of that subsequent strip. The open rock face 30 of the subsequent strip adjacent the previously excavated strip is covered by pushing overburden from the subsequent strip over the side edge of that strip adjacent the

- 9 -

previously excavated strip using suitable earth moving equipment, for example a bulldozer and the like.

Once the section of a given strip has been excavated, a floor 14 of that section is immediately covered with overburden from an adjacent strip or section after removal of the muck to deter a collection of water within that section. Having piled the overburden adjacent the previously open rock face of a given section being excavated acts as a dike for containing the section being excavated in a manner that removal of water from the working excavating area involves simply pumping water from that confined section as required. Removal of water however is typically not required because excavating equipment may be supported above the layer of rock adjacent respective sides of any given section being excavated.

Turning now to each of the figures independently, the method of operating the quarry area is described in further detail. As shown in Figure 1 stripping of the excavating portion of the quarry area begins by stripping a first section 26 at a first end of a selected first strip 28 opposite the processing plant 22. As shown also in Figure 2, overburden 16 of the first section is piled above the surrounding overburden about a periphery of the first section.

With reference to Figures 3 and 4, the layer of rock of the first section is blasted and excavated either before or after the next section adjacent the first section is stripped of overburden in a manner similar to the first section. When blasting and excavating the layer of rock for any given section of the selected first strip 28, a path of rock 32 is reserved along each side of the section or strip so as to leave an unblasted portion along side the section which defines a road for supporting rock trucks and the like thereon.

As shown in Figures 5 through 7 after an adjacent section to the section previously excavated is stripped, the overburden 16 is piled against the open

- 10 -

rock face 30 for covering the rock face to contain the blasted rock within that section as noted above. When excavating the subsequent section, a path of rock 32 along both sides of the subsequent section is again left unblasted and reserved for use as a road in communication with the road along side the previous section. As soon as possible after excavating the rock as shown in Figure 7, the floor of that section is again covered with overburden as shown in Figure 8 in which a subsequent section is similarly stripped with the first sections at respective first ends of the adjacent strips also being stripped of overburden.

Excavation of each section is performed by supporting excavating equipment such as back hoes on a top side of the layer of rock 12 on adjacent stripped sections, or on the paths of rock 32 which remain unblasted until the next strip is blasted, at which time a subsequent path of rock 32 along side that subsequent strip is again formed by reserving a portion to not be blasted. The back hoes reach down into the section being excavated for loading the muck onto suitable rock trucks which transport the muck along the roads formed on a top side of the layer of rock 12 for processing of the muck at the plant 22.

As shown in Figure 9, as the excavated area 34 becomes wider, spanning several strips 24, intermediate sections of road 36 are formed between adjacent strips so that the paths of rock 32 along side respective stripped and excavated sections remain in communication with one another to form a continuous road from the plant 22 to each of the sections being stripped or excavated adjacent the open rock face surrounding the excavated area 34. The intermediate road sections 36 span between respective sides of each strip at an interface between a stripped portion and an unstripped portion of that strip. Due to subsequent strips 24 being started when a previous strip has only been partly stripped, blasted or excavated, the roads formed by the paths of rocks 32 which remain unblasted form a

- 11 -

zigzagging path surrounding the excavated area 34. The path of rock 32 is reserved along side each strip after stripping and remains unblasted and unexcavated until the next strip adjacent the path of rock is blasted and excavated upon which another path of rock is reserved along side that next strip for defining the road on the surface
5 of the rock layer.

As shown in Figure 10 once the first strip 28 has been excavated the open rock face 30 at an interface between an adjacent strip 24 and the previously excavated strip 28 is covered with overburden, primarily from the overburden of the adjacent strips 24 which has been pushed into the previously excavated strip. After
10 stripping of the adjacent sections of the adjacent strips the entire upper surface of the stripped section is generally level with the surface of the roads defined by the respective paths of rock 32 along side each strip.

As shown in Figure 11 excavation of the adjacent strips defines the path of rock 32 as a shelf on the top surface of the layer of rock 12 which remains
15 stripped yet unexcavated and unblasted. After excavation of the adjacent strips, the overburden of the previously excavated strip may be levelled to span the full floor of the excavated area while stripping of the next adjacent strips of overburden permits the newly formed open rock face 30 to be again covered before blasting as noted above. As shown in Figure 13 the process of excavating subsequent strips while
20 reserving a path of rock 32 along side each new strip formed continues until the area is complete excavated. Once completed, the overburden lies on the floor of the quarry area, distributed substantially evenly across the floor so that little effort is required to reuse the land for other purposes once excavation of the rock is complete.

25 While one embodiment of the present invention has been described in the foregoing, it is to be understood that other embodiments are possible within the

- 12 -

scope of the invention. The invention is to be considered limited solely by the scope of the appended claims.

- 13 -

CLAIMS:

1. A method of operating a quarry area having a layer of rock covered by a layer of overburden, the method comprising:
 - a) dividing the area into a plurality of strips;
 - 5 b) stripping overburden from a selected first strip of the plurality of strips;
 - c) blasting and excavating the layer of rock from the first strip;
 - d) stripping overburden from a next strip adjacent the strip previously excavated;
 - 10 e) depositing overburden from the next strip within the strip previously excavated;
 - f) covering an open rock face of the next strip adjacent the strip previously excavated with overburden;
 - g) blasting and excavating the layer of rock from the next strip; and
 - 15 h) repeating steps d) through g).
2. The method according to Claim 1 including starting stripping the next strip before the strip previously excavated has been completely blasted and excavated.
3. The method according to Claim 1 including starting stripping the 20 next strip before the strip previously excavated has been completely stripped but after the strip previously excavated has been at least partly excavated.
4. The method according to Claim 1 including reserving a path of rock alongside of each strip after stripping which remains unblasted and unexcavated until the next strip adjacent the path of rock is blasted and excavated 25 upon which another path of rock is reserved alongside that next strip for defining a road on a surface of the rock layer.

- 14 -

5. The method according to Claim 4 including transporting rock excavated from each strip along the respective road defined alongside that strip using suitable trucks for transporting the rock to a processing plant.

6. The method according to Claim 1 including supporting
5 excavating equipment on an upper surface of the rock layer above a water table of the area and excavating rock below the water table.

7. The method according to Claim 1 including covering the open rock face of the next strip by pushing the overburden of the next strip over a side edge of the next strip adjacent the strip previously excavated which defines the open
10 rock face using suitable earth moving equipment until the rock face is sufficiently covered so as to contain rock within the next strip when the next strip is blasted.

8. The method according to Claim 1 including stripping, blasting and excavating each strip in sections starting with a first section adjacent one end of the strip.

9. The method according to Claim 8 including piling overburden
15 from the first section of the first strip above the overburden surrounding the first section.

10. The method according to Claim 8 including after stripping, blasting and excavating the first section of the strip:

20 i) stripping overburden from the next section adjacent the section previously excavated;

j) depositing overburden from the next section within the section previously excavated;

25 k) covering an open rock face of the next section adjacent the section previously excavated;

l) blasting and excavating the layer of rock from the next section;

- 15 -

and

m) repeating steps i) through l) until the strip is completely excavated.

5 11. The method according to Claim 8 including covering a floor of each section immediately after the section is excavated with overburden stripped from a next section adjacent the section.

12. The method according to Claim 1 wherein a width of each strip is substantially constant over a full length of the strip.

10 13. The method according to Claim 1 wherein the first strip is wider than the remaining strips.

14. The method according to Claim 1 including widening the next strip until sufficient overburden is stripped from the next strip that the open rock face is covered in a manner so as to contain rock within the next strip when the next strip is blasted.

15 15. The method according to Claim 1 wherein steps d) through g) are repeated until the area is completely excavated.

16. The method according to claim 1 including dividing only a portion of the area into a plurality of strips and locating a processing plant for excavated rock on a remaining portion of the area.

20 17. The method according to Claim 1 including proceeding with steps d) through g) on both sides of the first strip.

18. A method of operating a quarry area having a layer of rock covered by a layer of overburden, the method comprising:

25 a) dividing the area into a plurality of strips and dividing each strip into a plurality of sections;

b) stripping overburden from a first section at one end of a

- 16 -

selected first strip of the plurality of strips;

c) blasting and excavating the layer of rock from the first section;

d) stripping overburden from a next section of the strip adjacent the section previously excavated;

5 e) covering an open rock face of the next section adjacent the section previously excavated with overburden;

f) blasting and excavating the layer of rock from the next section;

and

g) repeating steps d) through f) until the strip is excavated.

10 19. The method according to Claim 18 including piling overburden from the first section above the overburden surrounding the first section.

20. The method according to Claim 18 including depositing stripped overburden from each section within the section previously excavated.

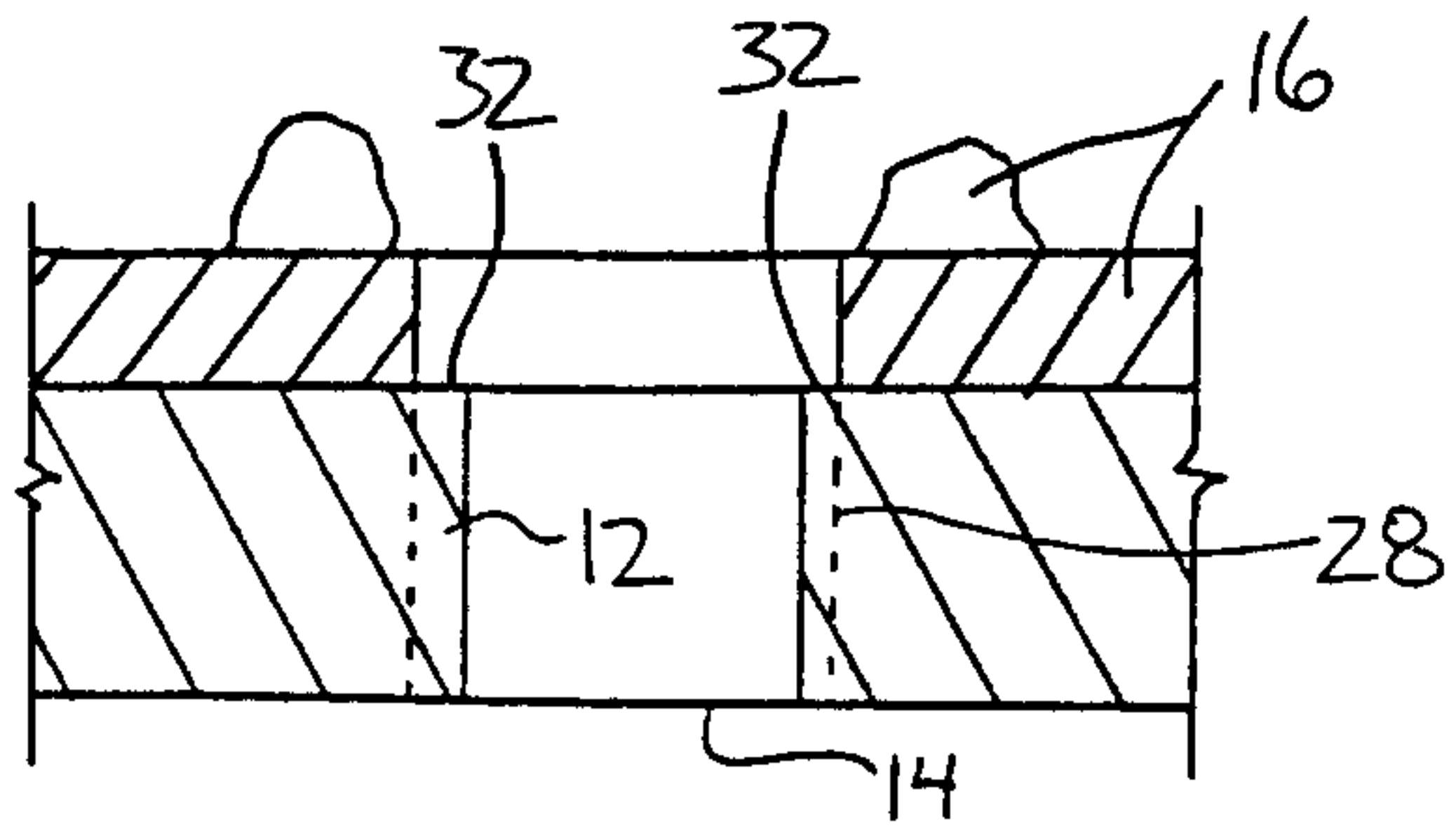
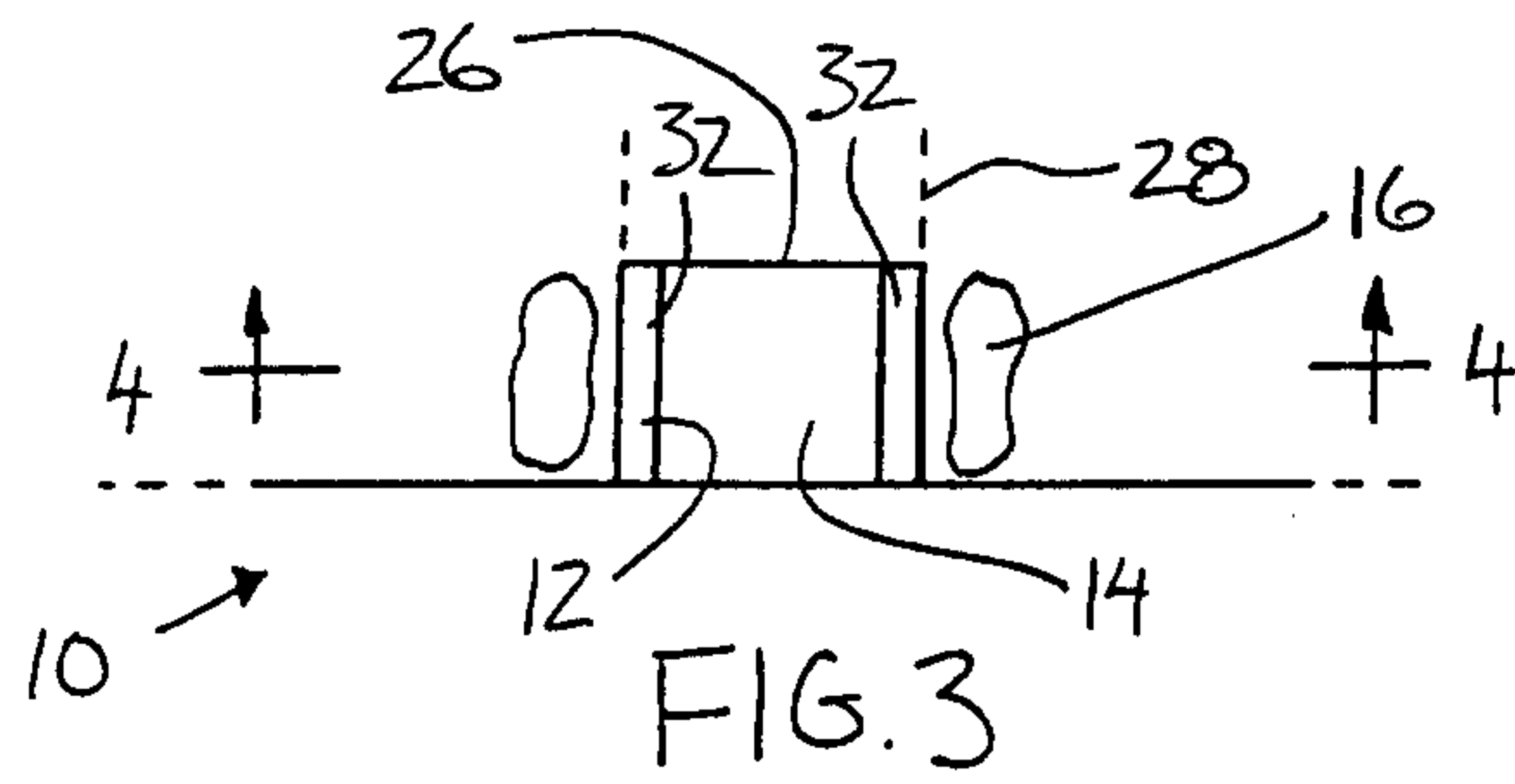
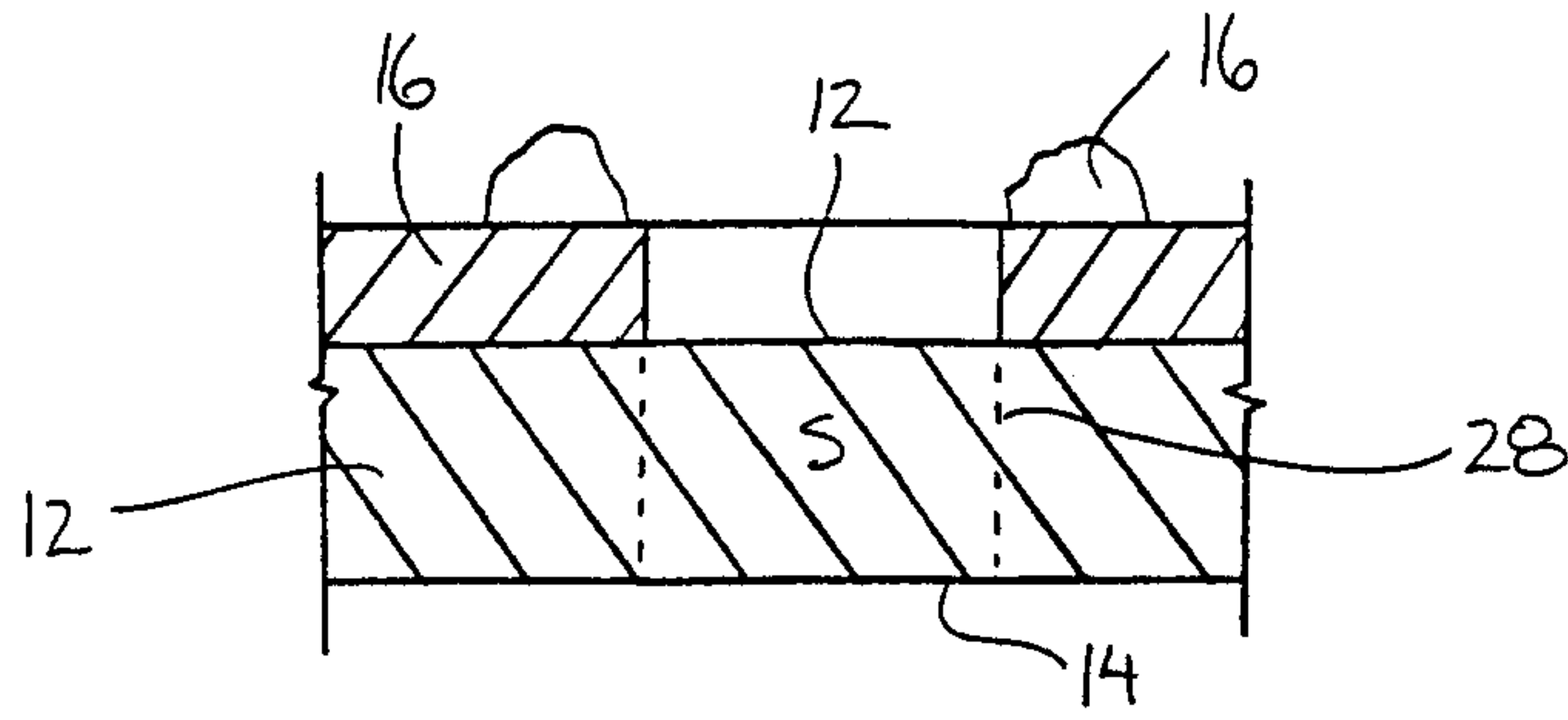
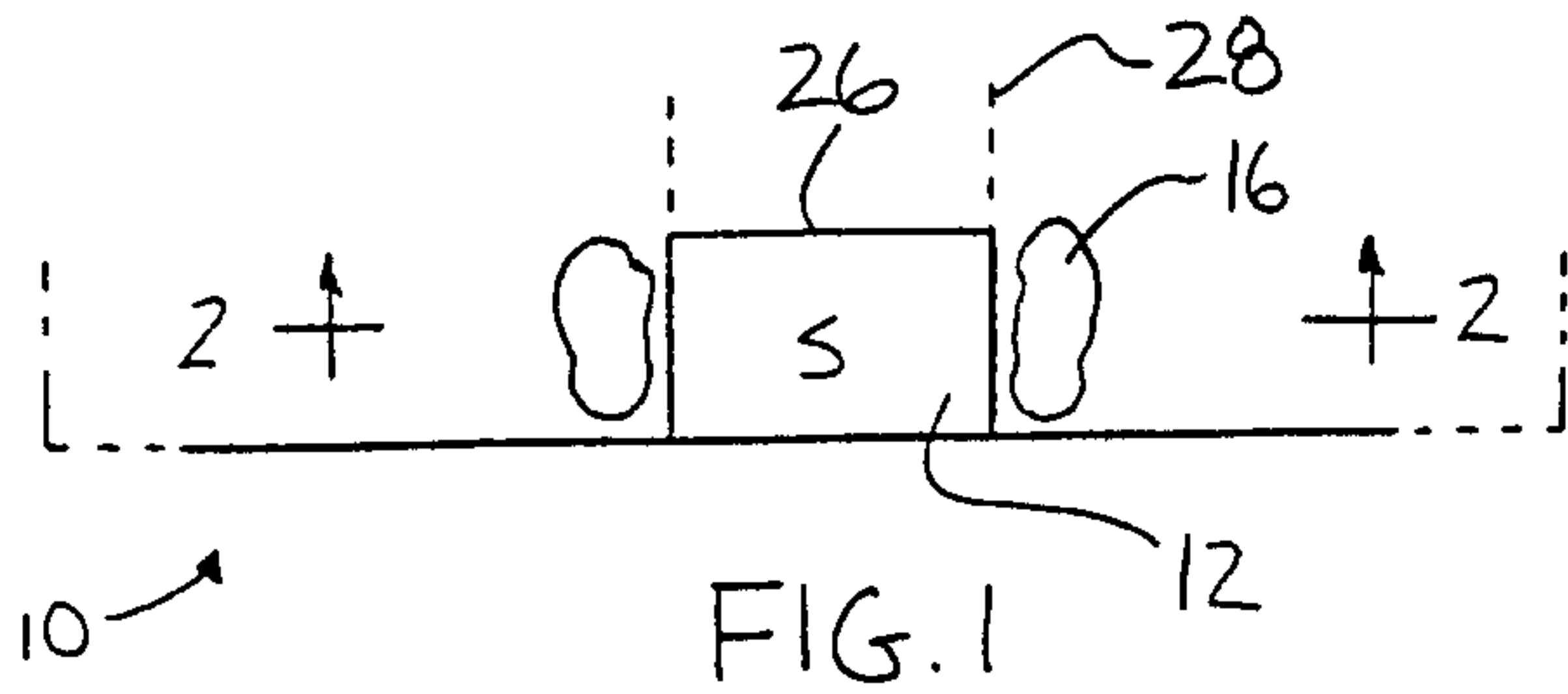

INVENTORS:

EDWARD J. WAKSHINSKY &
KENNETH M. WAKSHINSKY

PER:

ADE & COMPANY

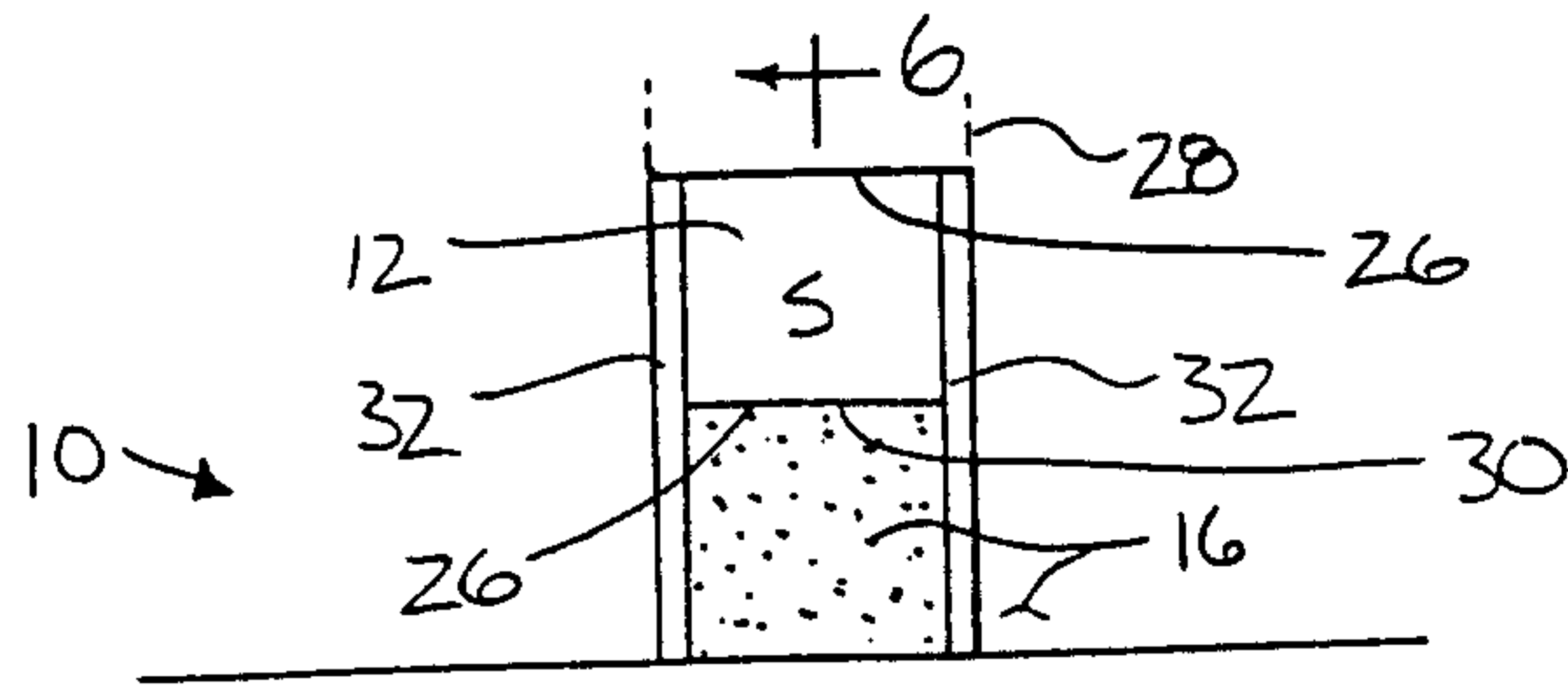

FIG. 5

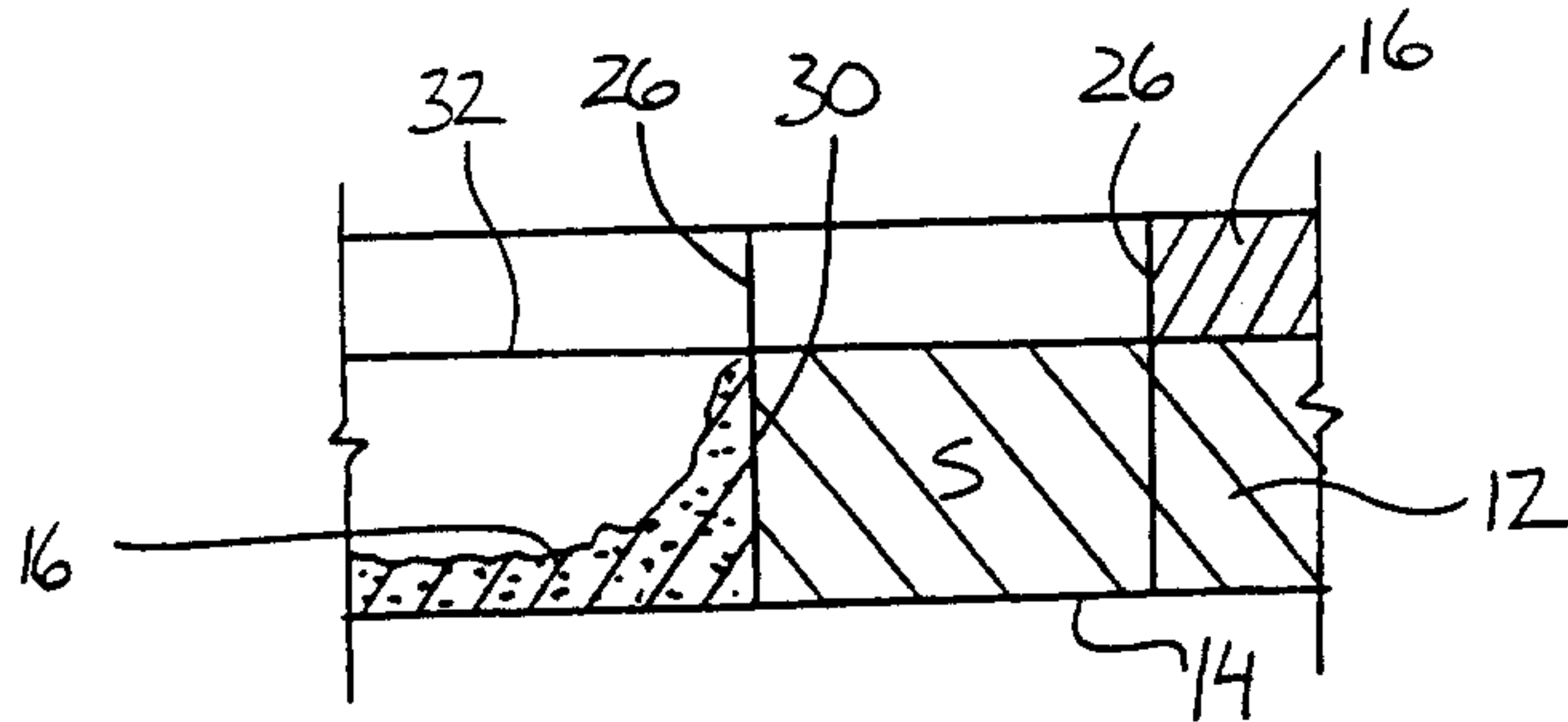

FIG. 6

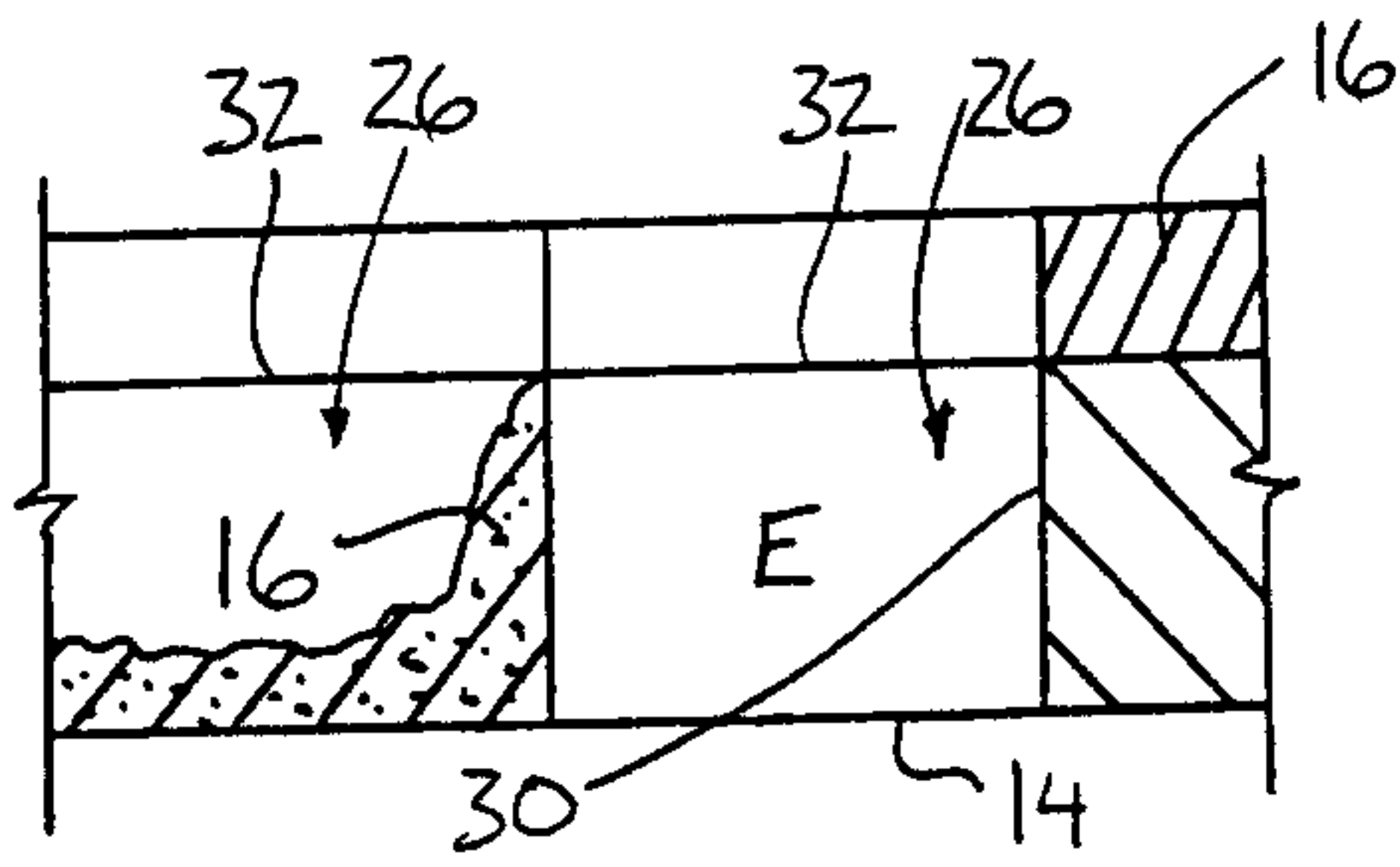
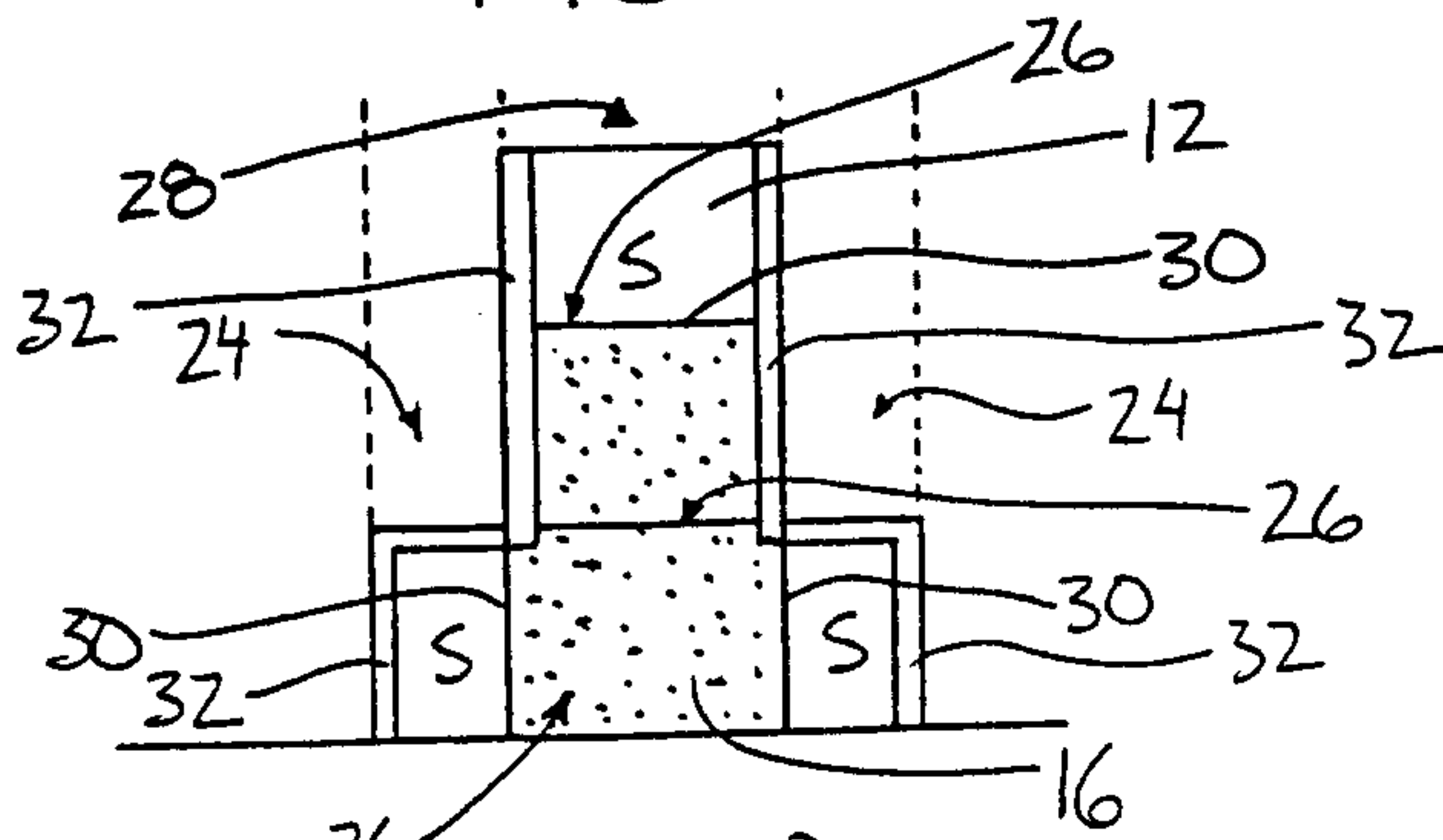

FIG. 7



INVENTORS:

EDWARD J. WAKSHINSKY &
KENNETH M. WAKSHINSKY

PER:

ADE & COMPANY

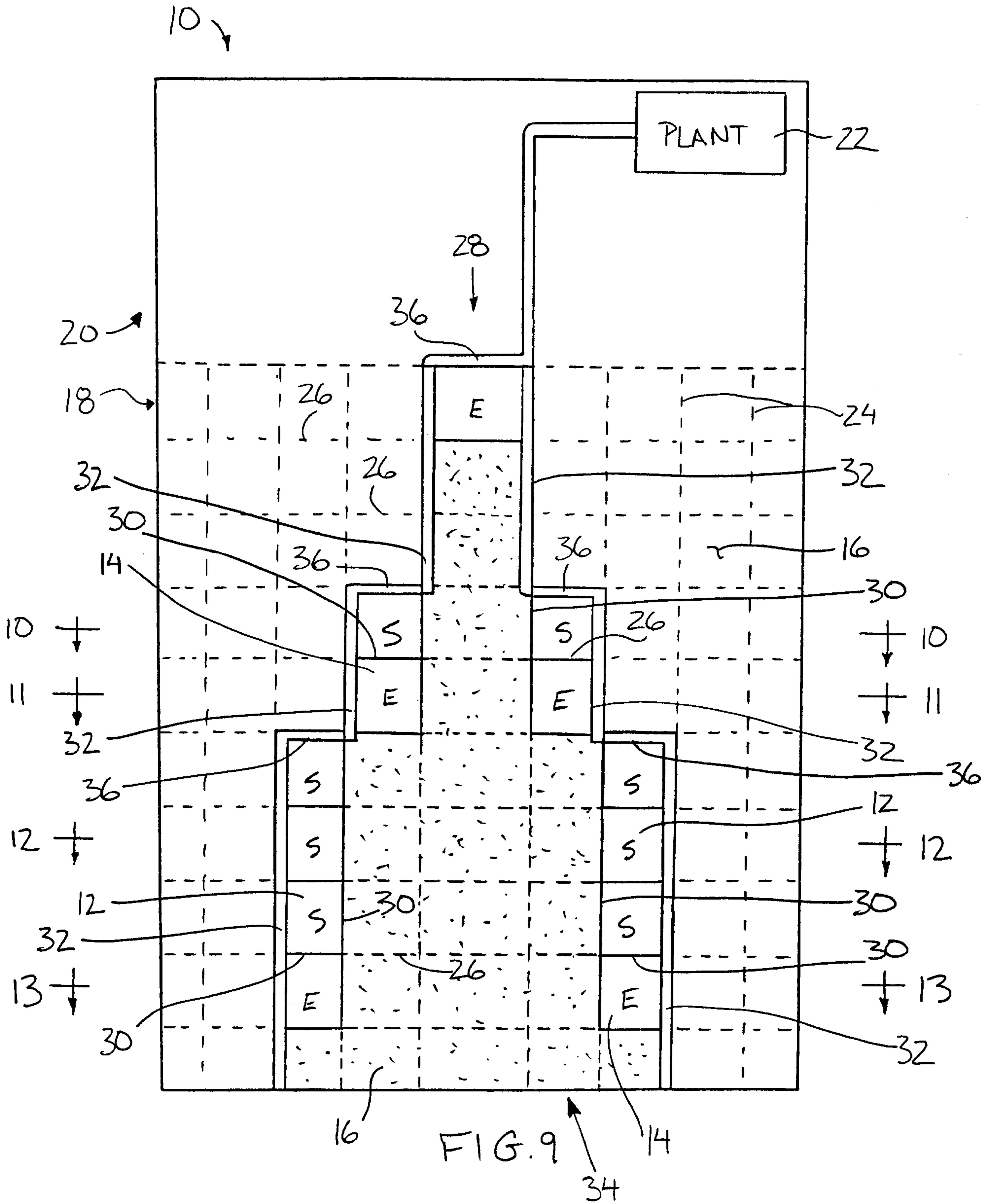

INVENTORS:
EDWARD J. WAKSHINSKY &
KENNETH M. WAKSHINSKY
PER:
ADE & COMPANY

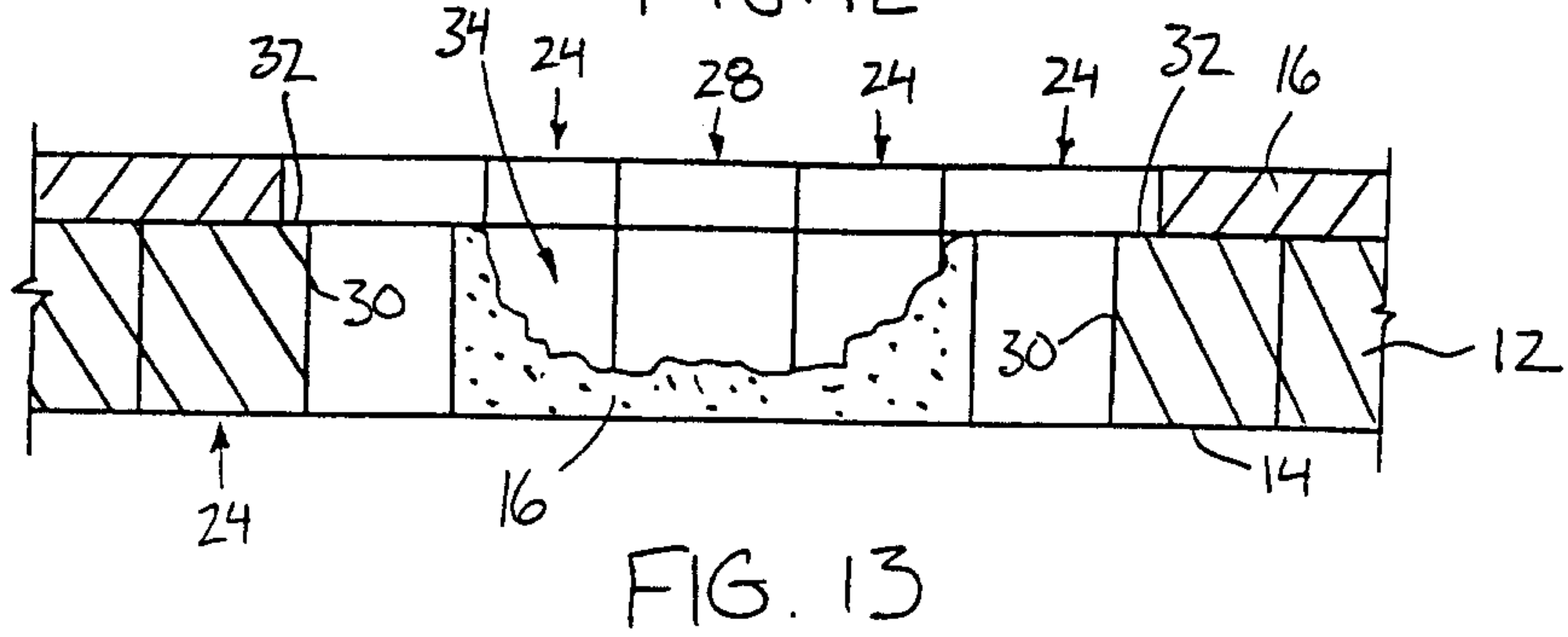
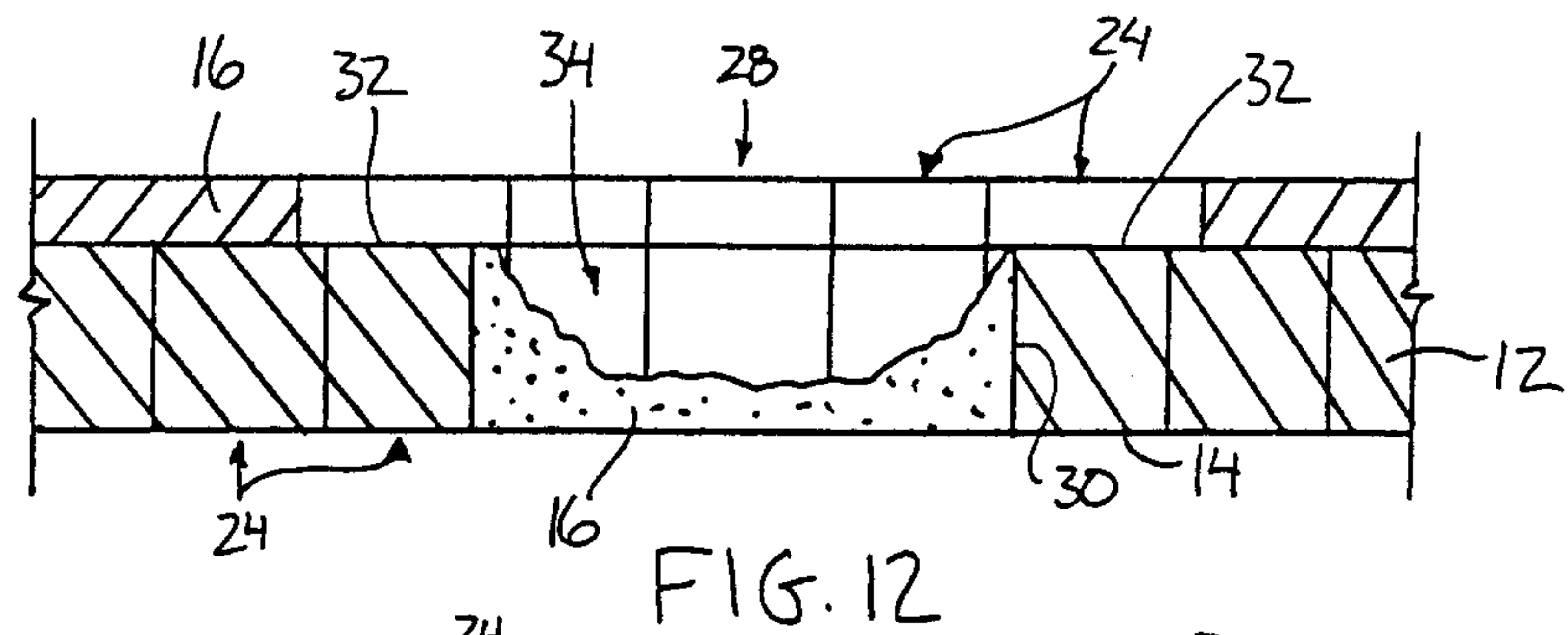
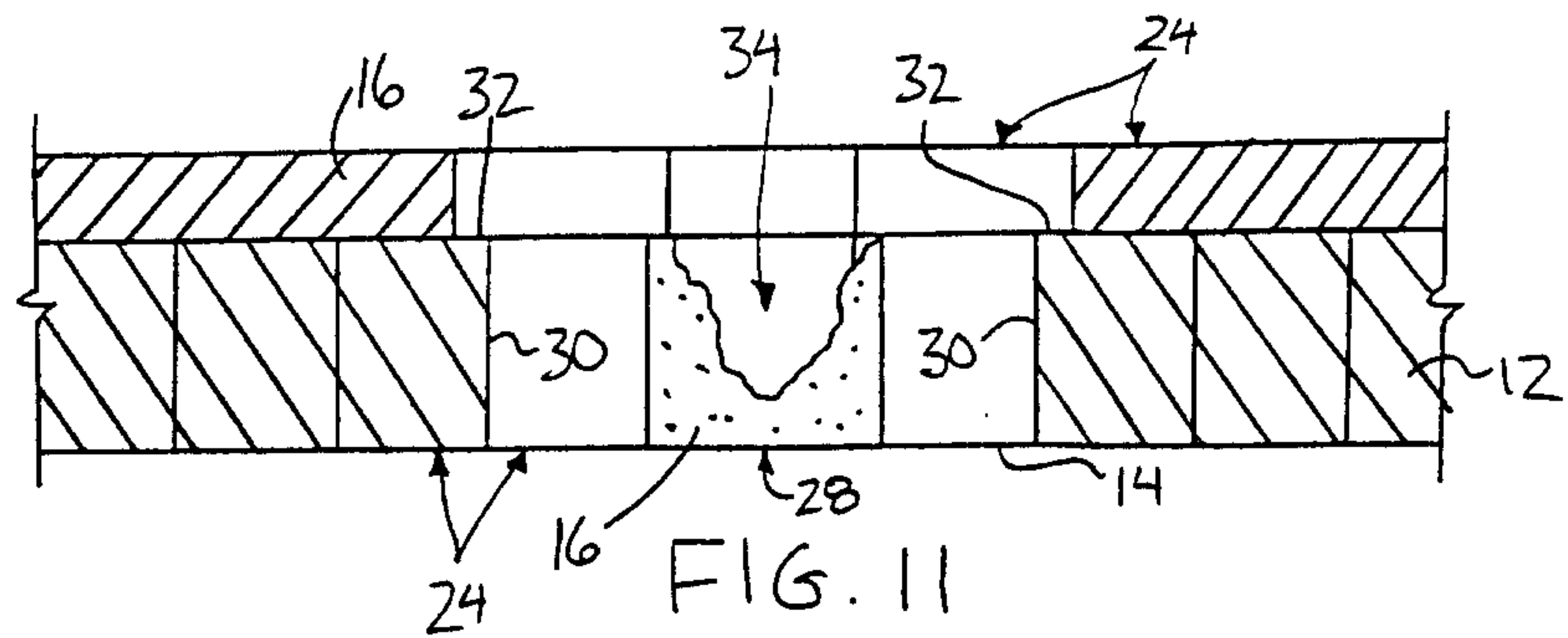
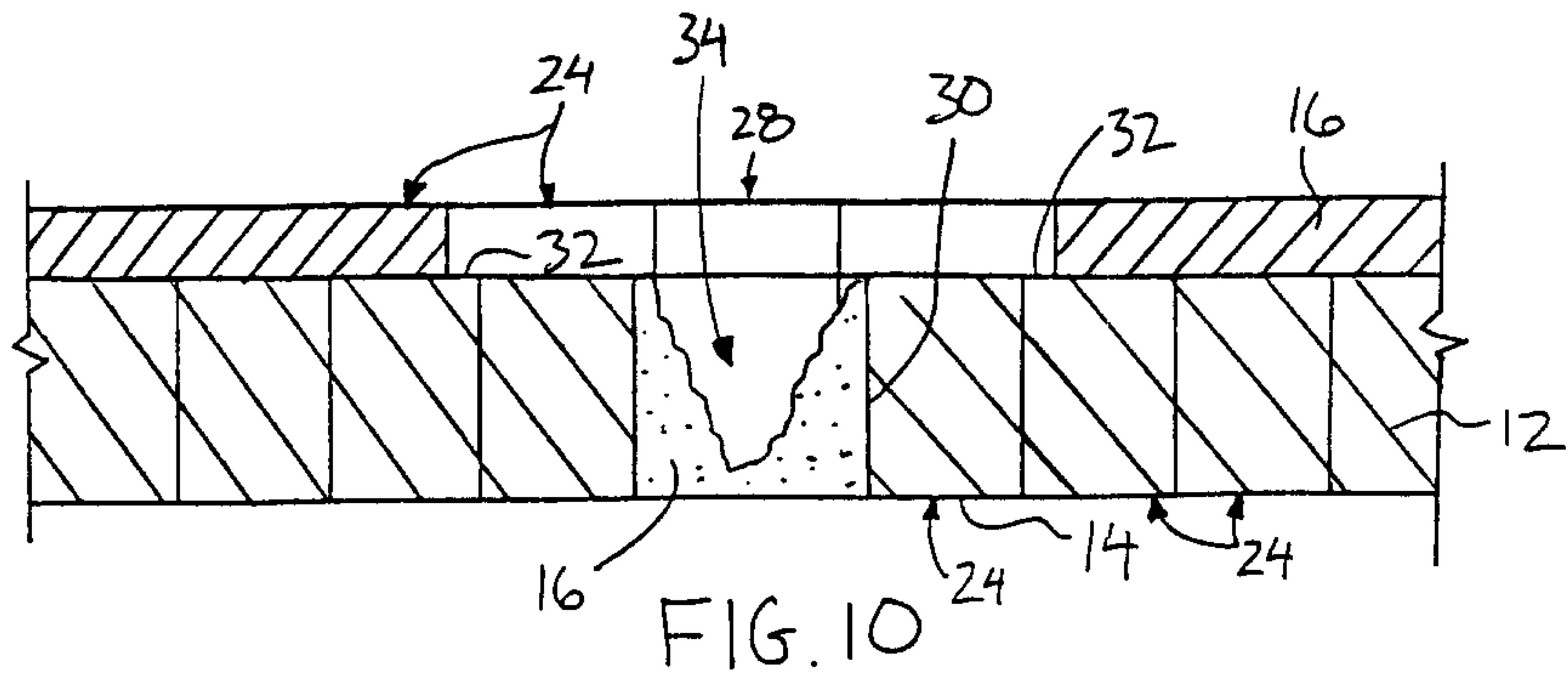

INVENTORS:
EDWARD J. WAKSHINSKY &
KENNETH M. WAKSHINSKY
PER:
ADE & COMPANY

10 ↘

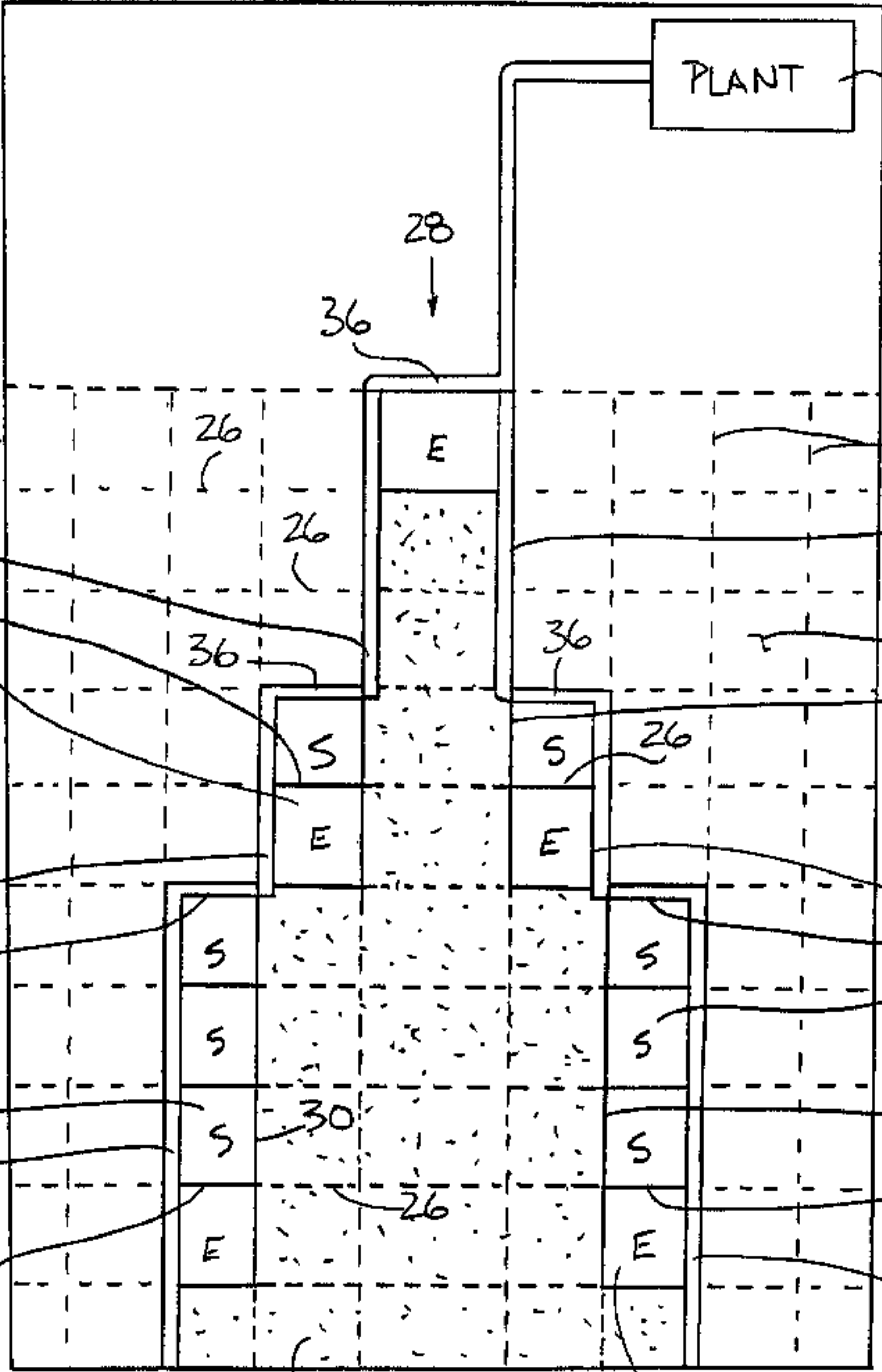

PLANT 22

28

36

E

22

20 ↗

18 ↗

26

24

32

26

32

30

36

36

16

14

S

S

26

30

10

10

11

11

32

32

36

36

12

12

12

12

32

30

13

30

30

26

30

32

16

34

14

32