

(19) World Intellectual Property
Organization
International Bureau



(43) International Publication Date
22 July 2004 (22.07.2004)

PCT

(10) International Publication Number
WO 2004/061863 A2

- (51) International Patent Classification⁷: G11L
- (21) International Application Number: PCT/US2003/041446
- (22) International Filing Date: 29 December 2003 (29.12.2003)
- (25) Filing Language: English
- (26) Publication Language: English
- (30) Priority Data:
 - 10/335,078 31 December 2002 (31.12.2002) US
 - 10/335,089 31 December 2002 (31.12.2002) US
- (71) Applicant: MATRIX SEMICONDUCTOR, INC.
[US/US]; 3230 Scott Boulevard, Santa Clara, CA 95054 (US).
- (72) Inventors: SCHEUERLEIN, Roy, E.; 22145 Orchard Ct., Cupertino, CA 95014 (US). PETTI, Christopher; 660 Sierra Ave., Mountain View, CA 94041 (US). WALKER,

Andrew J.,; 1638 Cornell Dr., Mountain View, CA 94040 (US). CHEN, En-Hsing; 931 Ponderosa Ave., #83, Sunnyvale, CA 94086 (US). NALLAMOTHU, Sucheta; 7203 Sharon Drive, San Jose, CA 95129 (US). ILKBAHAR, Alper; 1418 Four Oaks Rd., San Jose, CA 95131 (US). FASOLI, Luca G.,; 1229 Altissimo Place, San Jose, CA 95131 (US). KOUZNETSOV, Igor; 422 Hogarth Terrace, Sunnyvale, CA 94087 (US).

(74) Agents: ZAGORIN, O'BRIEN & GRAHAM, L.L.P.; GRAHAM, ANDREW, C., ET AL et al.; 7600B N. Capital of Texas Hwy., Suite 350, Austin, TX 78731-1191 (US).

(81) Designated States (national): AE, AG, AL, AM, AT, AU, AZ, BA, BB, BG, BR, BY, BZ, CA, CH, CN, CO, CR, CU, CZ, DE, DK, DM, DZ, EC, EE, EG, ES, FI, GB, GD, GE, GH, GM, HR, HU, ID, IL, IN, IS, JP, KE, KG, KP, KR, KZ, LC, LK, LR, LS, LT, LU, LV, MA, MD, MG, MK, MN, MW, MX, MZ, NI, NO, NZ, OM, PG, PH, PL, PT, RO, RU, SC, SD, SE, SG, SK, SL, SY, TJ, TM, TN, TR, TT, TZ, UA, UG, UZ, VC, VN, YU, ZA, ZM, ZW.

[Continued on next page]

(54) Title: PROGRAMMABLE MEMORY ARRAY STRUCTURE INCORPORATING SERIES-CONNECTED TRANSISTOR STRINGS AND METHODS FOR FABRICATION AND OPERATION OF SAME

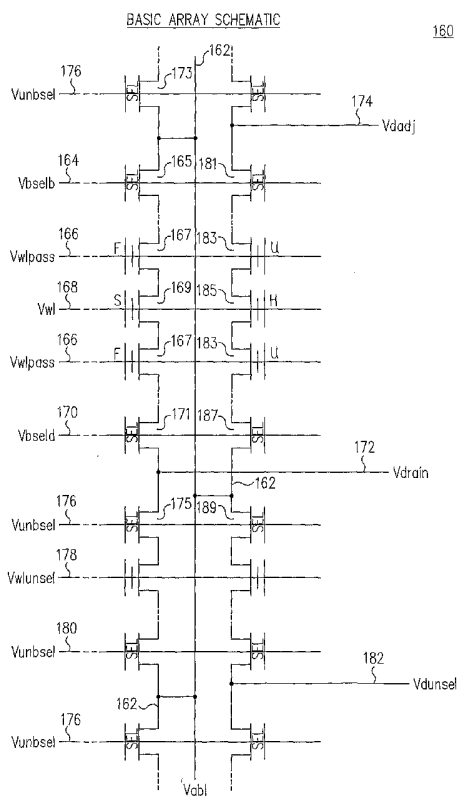

(57) Abstract: A three-dimensional flash memory array incorporates thin film transistors having a charge storage dielectric arranged in series-connected NAND strings to achieve a 4F2 memory cell layout. Each NAND string includes two block select devices for respectively coupling one end of the NAND string to a global bit line, and the other end to a shared bias node. Pairs of NAND strings within a block share the same global bit line. The memory cells are preferably depletion mode SONOS devices, as are the block select devices. The memory cells may be programmed to a near depletion threshold voltage, and the block select devices are maintained in a programmed state having a near depletion mode threshold voltage. NAND strings on more than one layer may be connected to global bit lines on a single layer, preferably connected together by way of vertical stacked vias.

WO 2004/061863 A2



(84) Designated States (regional): ARIPO patent (GH, GM, KE, LS, MW, MZ, SD, SL, SZ, TZ, UG, ZM, ZW), Eurasian patent (AM, AZ, BY, KG, KZ, MD, RU, TJ, TM), European patent (AT, BE, BG, CH, CY, CZ, DE, DK, EE, ES, FI, FR, GB, GR, HU, IE, IT, LU, MC, NL, PT, RO, SE, SI, SK, TR), OAPI patent (BF, BJ, CF, CG, CI, CM, GA, GN, GQ, GW, ML, MR, NE, SN, TD, TG).

Published:

— *without international search report and to be republished upon receipt of that report*

For two-letter codes and other abbreviations, refer to the "Guidance Notes on Codes and Abbreviations" appearing at the beginning of each regular issue of the PCT Gazette.

**PROGRAMMABLE MEMORY ARRAY STRUCTURE INCORPORATING SERIES-
CONNECTED TRANSISTOR STRINGS AND METHODS FOR FABRICATION AND
OPERATION OF SAME**

TECHNICAL FIELD

5 The present invention relates to semiconductor integrated circuits containing memory arrays, and in preferred embodiments the invention particularly relates to monolithic three-dimensional memory arrays having series-connected memory cells.

BACKGROUND ART

10 Recent developments in semiconductor processing technologies and memory cell technologies have continued to increase the density achieved in integrated circuit memory arrays. For example, certain passive element memory cell arrays may be fabricated having word lines approaching the minimum feature size (F) and minimum feature spacing for the particular word line interconnect layer, and also having bit lines approaching the minimum feature width and minimum feature spacing for the particular bit line interconnect layer. Moreover, three-dimensional memory arrays having more than one plane or level of memory cells have
15 been fabricated implementing such so-called 4F² memory cells on each memory plane. Exemplary three-dimensional memory arrays are described in U.S. Patent No. 6,034,882 to Johnson, entitled "Vertically Stacked Field Programmable Nonvolatile Memory and Method of Fabrication."

20 A variety of other memory cells technologies and arrangements are also known. For example, NAND flash and NROM flash EEPROM memory arrays are known to achieve relatively small memory cells. Other small flash EEPROM cells are known which use hot electron programming, such as NROM and floating gate NOR flash memory arrays. Such memory cells are less desirable for a 3D memory because they use many masks to produce a memory layer, and some use relatively high programming currents.

25 Other known memory structures are taught by U.S. Patent No. 6,163,048 by R.T. Hirose et al., entitled "Semiconductor Non-volatile Memory Device Having a NAND Cell Structure," which describes a memory array utilizing silicon/oxide/nitride/oxide/silicon (SONOS) cells arranged in a NAND architecture in crystalline silicon. U.S. Patent No. 6,005,270 by T. Noguchi et al., entitled "Semiconductor Nonvolatile Memory Device and Method of Production of Same," describes a memory array utilizing thin-film transistor (TFT) SONOS cells formed on a low-cost substrate such as glass or plastic. U.S. Patent No. 5,568,421 by S. Aritome, entitled "Semiconductor Memory Device on which Selective Transistors are Connected to a Plurality
30 of Respective Memory Cell Units," describes a NAND flash memory array having TFT block select devices and bulk silicon flash cell devices. U.S. Patent No. 5,621,683 by N. D. Young, entitled "Semiconductor Memory with Non-Volatile Memory Transistor," describes a memory array including TFT memory cells of a dielectric storage type arranged in a configuration other than a NAND architecture.

35 Despite such progress, memory arrays having even greater density are desirable. In particular, a memory array technology easily fashioned into a three-dimensional memory array is highly desired.

DISCLOSURE OF THE INVENTION

An extremely dense memory array may be achieved by using thin film transistors having a charge storage dielectric, and which are connected in a NAND-style architecture. In an exemplary embodiment, a flash memory array may be formed by series-connected NAND strings of SONOS memory cell devices. Each NAND string of memory cells includes a first block select device which couples one end of the NAND string to a global bit line, and a second block select device which couples the other end of the NAND string to a shared bias node associated with the string. Preferably the block select devices are also SONOS devices and may be formed in an identical fashion as the memory cell transistors, thus reducing the number of different structures necessary for each NAND string.

Pairs of NAND strings within a memory block on a level of the memory array preferably share the same global bit line. Two block select signals for the block are routed to each NAND string. Each of the NAND strings within the block share the same word lines, but their control signals are reversed for the pairs of NAND strings. For example, the first block select signal couples one NAND string to the global bit line and couples the other NAND string to a first shared bias node, while the second block select signal couples the other NAND string to the global bit line and couples the first NAND string to a second shared bias node.

In certain embodiments, the block select devices and the memory cells devices are SONOS devices. A range of threshold voltages is contemplated, but preferably such devices are formed having a depletion mode threshold voltage. Even more preferably the block select devices and the memory cells devices are N-channel devices having a thermal equilibrium threshold voltage of -2 to -3 volts. For the memory cells, such a threshold voltage preferably corresponds to an erased data state, and the memory cells are programmed to a near depletion threshold voltage of from -1 volt to 0 volts. The block select devices are preferably fabricated having the same thermal equilibrium threshold voltage but are maintained in a programmed state having a near depletion mode threshold voltage.

In certain embodiments, a multi-level memory array includes memory cells formed on each of several memory planes or memory levels. NAND strings on more than one layer may be connected to global bit lines on a single layer. Such a global bit line layer is preferably disposed on a layer of a monolithic integrated circuit below all the memory levels for more convenient connection to support circuitry for the memory array, which may be disposed in the substrate below the array. In some embodiments such a global bit line layer may reside in the midst of the memory levels, or above the array. Moreover, the NAND strings on more than one layer may also be connected to shared bias nodes on a single layer, which preferably is disposed above all the memory levels. In some embodiments, the shared bias nodes may reside in the midst of the memory levels, or below the array. The shared bias nodes may likewise be disposed on more than one layer.

The present invention in preferred embodiments achieves a $4F^2$ layout for each memory cell. Moreover, by interleaving the NAND strings on each memory level and using more than one shared bias node per block, very little additional overhead is required for the switch devices at each end of the NAND strings. In certain three-dimensional embodiments the NAND strings on different levels are preferably connected together by way of vertical stacked vias. Each stacked via preferably connects to a channel or word line

- 3 -

feature on more than one memory level. The invention is particularly well suited for a three-dimensional memory array because each level of memory cells may be produced with an average of less than three masks per level: one for defining channel stripes on each memory level, another for defining gate stripes on each memory level, and a via mask shared by at least three memory levels. An exemplary eight level memory array
5 may be formed using only 19 masking steps.

In addition to the density achieved, preferred embodiments of the present invention provide a memory array which may be programmed and erased using only tunneling currents, and which does not form leakage paths through non-selected memory cells in the memory array. Consequently, a memory of even greater density may be achieved since the memory array may be sized with relatively little regard for such unwanted
10 leakage currents.

The invention in several aspects is suitable for integrated circuits having a memory array, for memory cell and memory array structures, for methods for operating such integrated circuits and memory arrays, for methods for forming or fabricating such integrated circuits and memory arrays, and for computer readable media encodings of such integrated circuits or memory arrays, all as described herein in greater detail and as
15 set forth in the appended claims.

The foregoing is a summary and thus contains, by necessity, simplifications, generalizations and omissions of detail. Consequently, those skilled in the art will appreciate that the foregoing summary is illustrative only and that it is not intended to be in any way limiting of the invention. Other aspects, inventive features, and advantages of the present invention, as defined solely by the claims, may be apparent from the
20 detailed description set forth below.

BRIEF DESCRIPTION OF THE DRAWINGS

The present invention may be better understood, and its numerous objects, features, and advantages made apparent to those skilled in the art by referencing the accompanying drawings.

Fig. 1 is a perspective view of a multi-level array structure in accordance with an embodiment of the
25 present invention, showing series-connected NAND strings.

Fig. 2 is a cross-sectional view of a similar structure to that shown in Fig. 1.

Fig. 3 is a schematic diagram of a 4:1 interleaved NAND string structure in accordance with an embodiment of the present invention.

Fig. 4 is a schematic diagram of a several NAND strings within a memory level, in accordance with an
30 embodiment of the present invention.

Fig. 5 is a schematic diagram as in Fig. 4, showing exemplary read conditions for an embodiment of the present invention.

Fig. 6 is a diagram depicting exemplary waveforms for the exemplary read conditions of Fig. 5.

Fig. 7 is a schematic diagram as in Fig. 4, showing exemplary program conditions for an embodiment of the present invention.

Fig. 8 is a diagram depicting exemplary waveforms for the exemplary program conditions of Fig. 7.

5 Fig. 9 is a schematic diagram as in Fig. 4, showing exemplary erase conditions for an embodiment of the present invention.

Fig. 10 is a diagram depicting exemplary waveforms for the exemplary erase conditions of Fig. 9.

Fig. 11 is a schematic diagram depicting the interconnection of NAND strings on each of several memory levels, in accordance with an embodiment of the present invention.

10 Fig. 12, shown as Fig12A and Fig. 12B, is a flow diagram of an exemplary semiconductor process flow for forming a memory array in accordance with various embodiments of the present invention.

Fig. 13 is a flow diagram of a portion of an exemplary semiconductor process flow for forming a charge storage dielectric for a memory array in accordance with various embodiments of the present invention.

15 Fig. 14 is a flow diagram of a portion of an exemplary semiconductor process flow for forming a gate layer for a memory array in accordance with various embodiments of the present invention.

Fig. 15 is a flow diagram of a portion of an exemplary semiconductor process flow for forming a gate layer for a memory array in accordance with various embodiments of the present invention.

Fig. 16 is a flow diagram of a portion of an exemplary semiconductor process flow for forming a silicide layer for a memory array in accordance with various embodiments of the present invention.

20 Fig. 17 is a perspective view of a partially-completed memory array level, in accordance with various embodiments of the present invention.

Fig. 18 is a perspective view of a partially-completed memory array level, in accordance with various embodiments of the present invention.

25 Fig. 19 is a cross-sectional view of a portion of a NAND string within a memory array level, in accordance with various embodiments of the present invention.

Fig. 20 is a cross-sectional view of a portion of a NAND string within a memory array level, in accordance with various embodiments of the present invention.

30 Fig. 21 is a cross-sectional view of a portion of a NAND string within a memory array level, and showing an upper-portion of an underlying memory array level, in accordance with various embodiments of the present invention.

- 5 -

Fig. 22 is a cross-sectional view along a gate stripe and cutting across several NAND strings within a memory array level, and showing an upper-portion of an underlying memory array level, in accordance with various embodiments of the present invention.

Fig. 23 is a cross-sectional view between gate stripes and cutting across a NAND string within a memory array level, in accordance with various embodiments of the present invention.

Fig. 24 is a cross-sectional view of a via structure (i.e., a "zia") making contact to three layers of the memory array, in accordance with various embodiments of the present invention.

Fig. 25 is a layout diagram of a zia and three memory array layers which corresponds to the zia structure shown in Fig. 24.

Fig. 26 is a layout diagram of a multi-level 4:1 interleaved NAND string memory array structure which corresponds to the schematic diagram shown in Fig. 3, and includes zias as depicted in Fig. 24.

Fig. 27 is a cross-sectional view depicting the vertical interconnection of between the channel strings and gate strings within eight memory levels by use of only three zia levels, in accordance with various embodiments of the present invention.

Fig. 28 is a cross-sectional view of a via structure (i.e., a "zia") making contact to four channel string layers of a multi-level memory array, in accordance with various embodiments of the present invention.

Fig. 29 is a cross-sectional view of a chimney-like via structure (i.e., a "zia") making contact to four channel string layers of a multi-level memory array, in accordance with various embodiments of the present invention.

Fig. 30 is a layout diagram of a multi-level 2:1 interleaved NAND string memory array structure which might include zias as depicted in Fig. 29.

The use of the same reference symbols in different drawings indicates similar or identical items.

DESCRIPTION OF THE PREFERRED EMBODIMENT(S)

As used herein, an integrated circuit having a three-dimensional memory array is assumed to be a monolithic integrated circuit, rather than an assembly of more than one monolithic integrated circuit.

Referring now to Fig. 1, a three-dimensional view is shown conceptually depicting a portion of a two-level memory array 100 in accordance with the present invention. On level 1, a plurality of channel stripes (e.g., 102) is formed in a first direction. A stored charge dielectric layer 104, such as an oxide/nitride/oxide (ONO) stack, is formed at least on the top surface of the channel stripes 102. A plurality of gate stripes (e.g., 106) running in a second direction different than the first direction is formed on the stored charge dielectric layer 104. Preferably the gate stripes, also called word line stripes, run generally orthogonally to the channel

- 6 -

stripes. A source/drain region (e.g., 110) is formed in the channel stripes in the exposed regions between the word line stripes (i.e., not covered by a word line stripe), thus forming a series-connected string of thin-film transistors (TFT).

Such channel stripes 102 are preferably formed by depositing a poly-crystalline polysilicon layer and etching the layer using a channel mask to form the channel stripes. The word line stripes 106 may be formed of a stack of more than one layer, such as a polysilicon layer covered by a silicide layer, or may be a three level stack, as shown in the figure, all as described in greater detail herebelow.

An interlevel dielectric layer 108 is formed above the word line stripes to isolate the word lines on one level (e.g., word line stripes 106 depicted on level 1) from the channel stripes on the next higher level (e.g., channel stripes 102 depicted on level 2). As is described in greater detail below, a dielectric may also be used to fill spaces between the word line stripes of a given level.

As can be appreciated, such a structure forms a plurality of series-connected transistors within each channel stripe 102. Fig. 2 shows a cross-sectional view of such a plurality of series-connected transistors, which may also be referred to as a series-connected transistor string, and also as a series-connected NAND string. Four word lines 106 are shown, forming four individual transistors connected in series along the channel stripe 102. In this example, the channel stripe 102 is formed from a lightly-doped p-type (i.e., P-doped) polycrystalline layer, and includes a heavily-doped n-type (i.e., N+ doped) source/drain region 110 formed in the channel stripe 102 between the word lines 106. The channel region of each respective transistor is formed in the channel stripe 102 beneath the respective word line 106, and preferably includes a channel dopant region 112 to adjust the transistor threshold, lying above a P- region of the channel stripe 102. A via 114 is depicted connected to one end of the channel stripe 102 for making connections to support circuitry for the array, as described in greater detail herebelow.

The transistors of such a NAND string may be fabricated to contain enhancement or depletion mode devices for the programmed state. In other types of NAND memory arrays using floating gate devices (rather than SONOS devices), the erased state is often a zero-volt threshold voltage (V_T) or even a depletion mode V_T . But a floating gate device can have a wide range of V_T 's because the floating gate can store a wide range of charge levels. Consequently, it is more straightforward to make a depletion mode programmed state, as is described in "A Negative V_{th} Cell Architecture for Highly Scalable, Excellently Noise-Immune, and Highly Reliable NAND Flash Memories" by Takeuchi et al., in IEEE JSSC, Vol. 34, No. 5, May 1999, pp. 675-684. Achieving such a depletion mode erased state has not been done before in a NAND array incorporating SONOS devices.

For many memory arrays, and especially for a three-dimensional (3D) memory, utilizing depletion mode devices when erased and near depletion mode devices (i.e., around zero volt V_T) when programmed has a great advantage in simplifying the layout complexity for each of the memory layers, as described herebelow. Moreover, utilizing near depletion mode devices when programmed reduces the voltages that need to be applied to the unselected word lines when reading a selected memory cell. The cell current can pass more

easily through the string even if unselected memory cells are programmed. This voltage reduction is beneficial for reducing disturb effects during the many expected read cycles. For example, an unselected memory cell on an unselected NAND string which is erased could be slowly disturbed to a programmed state by higher voltages on the word lines.

5 The memory structure of Fig. 2 may be fabricated using only two masking layers per memory level-one to define the channel stripes, and another to define the word line stripes. As is described herebelow, a third mask for contacting the layers of the memory level is not necessarily required, as contact structures may be incorporated that achieve electrical connection to at least three layers using a single via mask.

 Referring now to Fig. 3, an electrical schematic is shown of a portion of an exemplary memory array.
10 The portion shown may represent a two-dimensional array having only one plane of memory cells, or may represent one level of three-dimensional memory array having more than one level (i.e., more than one plane) of memory cells. A plurality of series-connected NAND transistor strings is shown, one of which is labeled 122. Each string includes a plurality of SONOS transistors connected in series, each gated by a respective one of a plurality of word lines 125. The NAND string 122 also includes a block select device 148 for coupling
15 one end of the NAND string to a global bit line contact 131 in accordance with a block select signal BSEL2 conveyed on node 126, and further includes a second block select device 147 for coupling the other end of the NAND string to a shared bias node 128 in accordance with a block select signal BSEL1 conveyed on node 124. The global bit line contact 131 is shared with another NAND string 132 which is disposed on the other side of (i.e., opposite) the global bit line contact 131 and is independently selectable by another block select
20 signal BSEL3.

 As is depicted in the figure, a group of four laterally adjacent NAND strings share a common bias node 128, which may be termed VDRAIN1, disposed at the left end of the NAND strings, but are individually coupled to a respective one of four global bit line contacts disposed at the right end of the NAND string. The next group of four laterally adjacent NAND strings is reversed, and the NAND strings in the group are
25 individually coupled to a respective one of four global bit line contacts disposed at the left end of the NAND strings. This next group of NAND strings shares a common bias node 129, which may be termed VDRAIN2, disposed at the right end of the NAND strings. As may be appreciated, the block select signal BSEL1 couples the left end of half of the NAND strings to an associated global bit line, while the same signal couples the right end of the other half of the NAND strings to the shared bias node VDRAIN1. Similarly, block select signal
30 BSEL2 couples the right end of half of the NAND strings to an associated global bit line, while the same signal couples the right end of the other half of the NAND strings to the shared bias node VDRAIN2.

 This structure interleaves the NAND strings by coupling two different NAND strings to the same global bit line. For example, the left end of NAND string 134 is coupled by BSEL1 to a global bit line contact 138, while the right end of NAND string 136 is coupled by BSEL2 to a global bit line contact 140. These two
35 global bit line contacts 138 and 140 are preferably connected to the same global bit line, which may be routed horizontally on a wire 146 conveyed on a different wiring level. Such global bit lines may be conveyed a wiring level below the array, or alternatively above the array, or alternatively on a wiring level within the array

- 8 -

(e.g., in a three-dimensional array having more than one level). The NAND string 134 and 136 may be referred to as "adjacent" NAND strings, as sharing the same global bit line and sharing the same word lines (i.e., within the same block of the array), even though there is another NAND string disposed between them. It is still possible to select only one of these two NAND strings for reading and writing because the shared bias nodes VDRAIN1 and VDRAIN2 are distinct and may be driven to different conditions, as is described in regards to the next several figures. Each of these two shared bias nodes VDRAIN1 and VDRAIN2 is shared by NAND strings in two adjacent blocks, and thus are preferably conveyed in vertical wires 142 and 144, respectively, which are preferably conveyed on a wiring level "above" the memory array (i.e., further from the semiconductor substrate). Consequently, the two shared bias nodes VDRAIN1 and VDRAIN2, the block select signals BSEL1 and BSEL2, and the various word lines 125, which all traverse across the memory array in the same direction, may be more conveniently decoded and driven to appropriate levels.

As described above, the memory cells in the NAND strings (i.e., those gated by one of the word lines) are preferably SONOS structures. As used herein, the term SONOS is meant to refer to the general class of transistor devices having a charge storage dielectric layer between the gate and the underlying channel, and is not used in a restrictive sense to merely imply a literal silicon-oxide-nitride-oxide-silicon layer stack. For example, other kinds of dielectric layers may be employed, such as oxynitrides, as is described in greater detail herebelow.

A basic NAND string is a very efficient structure, capable of achieving a $4F^2$ layout for the incremental transistor memory cell. However, providing the necessary switch devices with appropriate control signals at the ends of the NAND strings, and the overhead of connecting such NAND strings to global bit lines and to bias or ground nodes, frequently degrades the resultant total efficiency. In contrast, the structure depicted in Fig. 3 achieves very dense layout because of the interleaving of two NAND strings, both coupled to the same global bit line, thus relaxing the pitch requirements for the global bit lines by a factor of two. The structure depicted in Fig. 3 also achieves very dense layout because only one control signal is utilized at each end of the NAND strings. This allows the two block select lines BSEL1 and BSEL2 to route in continuous polysilicon stripes across the plurality of channel stripes, just like the word lines, without any provision being otherwise required for contacting a block select signal line to some but not all of the block select transistors formed in the channel stripes.

Another factor contributing to the efficiency of this array structure is the ability of the block select devices to be fabricated identically to the memory cell devices. In other words, the block select devices may be SONOS devices just like the memory cell devices. In 3D array embodiments having more than one memory level formed above a semiconductor substrate, each memory level consequently includes only one type of device, further simplifying the fabrication of each level. The block select devices may be sized identically to the memory cell devices, but preferably may have a longer channel length (i.e., wider polysilicon stripe for the block select signals) to increase the breakdown voltage of the block select devices.

In a preferred embodiment, the memory cell devices and block select devices are both SONOS devices which are implanted to shift the thermal equilibrium (i.e., minimum trapped charge in the nitride) threshold

- 9 -

voltage V_T to depletion mode. A depletion mode implant that is a slow diffuser, preferably antimony or arsenic, is preferably used because of the relatively higher diffusion of such dopants in a polycrystalline layer compared with a crystalline substrate, and also due to the extremely small dimensions of the devices. The erased state V_T is substantially depletion mode, preferably -2V to -3V threshold, while the programmed state V_T is preferable about zero volts. The memory cells are programmed or erased to one of the two threshold voltages according to the data state, but the block select devices are preferably programmed to have about a zero-volt threshold voltage and maintained in this programmed state

Referring now to Fig. 4, a schematic diagram is introduced showing two different NAND strings in each of two blocks which may be coupled to the same global bit line. The terminology and structure described here is used in the next several figures to describe the basic read, program, and erase functions for such an array configuration. The portion shown may represent a two-dimensional array having only one plane of memory cells, or may represent one level of three-dimensional memory array having more than one level of memory cells. The basic operation will be described in the context of a single memory level and also for a multi-level array.

In the descriptions that follow, the upper left NAND string is assumed to be the selected NAND string. The selected word line 168 is driven to a V_{WL} voltage, and the selected memory cell 169 is indicated by an "S." Other non-selected word lines 166 in the same block as the selected word line 168 may be termed "passing" word lines because these are usually driven to a V_{WLPASS} voltage suitable to pass current through its respective memory cell 167 irrespective of the stored data state in its respective memory cell 167. Only two such passing word lines 166 and one selected word line 168 are depicted, but it should be appreciated that in practice each NAND string may include many word lines, such as 16 total word lines.

One end of the selected NAND string is coupled to a global bit line 162 by select device 165 which is controlled by a block select signal conveyed on node 164 having a voltage at any given time known as the V_{BSELB} voltage, which signal may be thought of as the block select signal coupling the selected NAND string to the global bit line. The other end of the selected NAND string is coupled to a shared bias node 172 by select device 171 which is controlled by a block select signal conveyed on node 170 having a voltage of V_{BSELD} , which signal may be thought of as the block select signal coupling the selected NAND string to the shared drain line. The voltage of the shared drain line 172 may be known as the V_{DRAIN} voltage.

Another NAND string (not shown) within the block just above the selected block is also coupled to the global bit line 162 by a select device 173 which is controlled by a block select signal conveyed on node 176 having a voltage at any given time known as the V_{UNBSEL} voltage, which signal may be thought of as an unselected block select signal. The two select devices 173 and 165 preferably share a global bit line contact.

An adjacent NAND string is also depicted just to the right of the selected NAND string. As stated above, such adjacent NAND strings share the same word lines and are coupled to the same global bit line (i.e., by two different block selected signals), but do not share the same shared bias node (i.e., "drain" node). Here the adjacent NAND string includes devices 181, 183, 185, and 187. The lower end of this adjacent NAND

- 10 -

string is coupled to the global bit line 162 by select device 187 which is controlled by the block select signal conveyed on node 170, here referred to as $V_{\text{BSEL D}}$. The upper end of this adjacent NAND string is coupled to a shared bias node 174 by select device 181 which is controlled by the block select signal conveyed on node 164, $V_{\text{BSEL B}}$. The voltage of the shared drain line 174 may be known as the V_{DADJ} voltage, representing the drain voltage for an adjacent NAND string.

The memory cell devices in the adjacent NAND string merit brief mention, for their respective bias conditions in the various operating modes are important. Two memory cell devices labeled 183 are driven by a passing word line 166 and may be termed unselected memory cells (labeled with a "U"). Another memory cell device 185 is driven by the selected word line 168 and may be termed a half selected memory cell (labeled with an "H"). Such unselected and half-selected memory cells are found in other non-selected NAND strings across the selected memory block.

In the lower half of the figure, two additional NAND strings are also depicted which are located in the block just below the selected array block. Both of these NAND strings are unselected. The block select line 176 at end of both NAND strings and the other block select line 180 at the other end of the NAND strings are both biased at an unselected block select voltage, V_{UNBSEL} . An unselected word line 178 (representing the plurality of word lines in the unselected block) is biased at an unselected word line voltage, V_{WLUNSEL} . An unselected shared drain node 182 is shown, having a bias voltage of V_{DUNSEL} . Such a shared drain node is representative of any such drain node serving two unselected blocks.

These two lower NAND strings also represent the bias voltages impressed on the various nodes and devices within other non-selected blocks on the same level as the selected block. For certain three-dimensional array embodiments shown herein, these two lower NAND strings also represent the bias voltages impressed on the various nodes and devices within all blocks on the non-selected levels in the array.

Block select devices 187 and 189 share a contact to global bit line 162. Similarly, a shared bias node (i.e., VDRAIN) contact is also shared by a respective block select device on opposite sides of the shared contact (e.g., select devices 171 and 175). Moreover, as depicted in Fig. 3, four NAND strings within the same block share such a VDRAIN contact (although each is coupled to a respective global bit line) for a total of eight NAND strings on a given layer sharing each VDRAIN contact.

Read Operation

Referring now to Fig. 5, exemplary read conditions are shown for this array structure. The selected NAND string is read by impressing a voltage across the NAND string, ensuring that both block select devices are biased to pass a current, ensuring that all non-selected memory cell devices in the NAND string are biased to pass a current through the string irrespective of the data state stored therein, and biasing the selected word line so that current flows through the NAND string for only one of the two data states. One suitable set of read conditions includes driving the "global bit line" block select line $V_{\text{BSEL B}}$ to a positive power supply voltage V_{DD} (e.g., V_{DD} frequently being in the range from 2.5 to 3.3 volts) and driving the "drain" block select line $V_{\text{BSEL D}}$ also to V_{DD} . The voltage of the global bit line 162 (i.e., V_{GBL}) is approximately 2 volts, and V_{DRAIN} is

approximately 2.5 volts. The data state of the selected memory cell may be determined by maintaining the voltage bias on the global bit line and sensing current flow on the global bit line by a sensing circuit 190, which may be either directly coupled to the global bit line or may be shared among several global bit lines and coupled by decoding circuitry to a desired global bit line. Suitable voltage-clamped bit line sensing circuits are described in “Current Sensing Method and Apparatus Particularly Useful for a Memory Array of Cells Having Diode-Like Characteristics” by Roy E. Scheuerlein, now published as U.S. Patent Application Publication No. US 2003/0021148 A1.

Referring briefly to Fig. 6, all the word lines in the selected block are driven to approximately 2 volts to charge the intermediate nodes of the selected NAND string (i.e., the source/drain regions between each device) to a voltage having a value between the V_{GBL} voltage and the V_{DRAIN} voltage. Then the selected word line is decreased to approximately 1 volt so that current will still flow through the selected device 169 if erased (i.e., having a threshold of around -2 volts) and yet will prevent current flow if the selected device 166 is programmed (i.e., having a threshold of around 0 volts).

The V_{DADJ} voltage is preferably driven to substantially the same voltage as the V_{GBL} voltage, so that substantially no bias voltage is impressed across the adjacent NAND string. Consequently, even though its block select devices 181 and 187 are turned on, no current flows through the adjacent NAND string onto the global bit line 162 which would interfere with sensing the current on the global bit line 162. The intermediate nodes in the adjacent NAND string are all biased at approximately 2 volts since only the selected word line 168 is at a voltage lower than 2 volts, and since every memory cell and block select device has a threshold no higher than approximately 0 volts. As a result, the read disturb condition on the unselected devices 183 (i.e., the bias voltage from gate to source/drain) is essentially zero, and read disturb condition for the half selected cell 185 is approximately -1 volt. Looking back to the selected NAND string, since the intermediate nodes in the selected NAND string are each biased at a voltage between 2 and 2.5 volts, the read disturb condition on the “F” devices 167 is approximately 0-0.5, and the read disturb bias on the selected device 169 is approximately -1 volt. These read disturb conditions, and the relative length of time a memory cell is exposed to such condition, are summarized in Table 1.

Table 1

READ DISTURB STRESS VOLTAGE AND TIME

CELL	VGS	STRESS CONDITION
S	- 1.0v	Basic read stress time
F	0 to .5v	More often by # cells in string
H	-1.0v	More often than basic by $\frac{\#unselectBLS}{selectedBLS}$
U	0	More often by both factors

The read condition has very low gate-to-source bias voltages impressed across the selected memory cell device because the threshold voltage of an erased cell has been shifted to approximately -2 volts. As a result,

- 12 -

a -1 volt gate-to-source voltage is sufficient to cause conduction through the transistor for the erased state but not for the programmed state, and thus allows discerning the data state of the cell. Moreover, the depletion mode erased state allows all four memory cell devices (i.e., S, F, H, and U) to have very low read disturb bias, but is particularly important for the unselected "U" devices to have virtually no read disturb bias voltage, as a given memory cell must endure many more cycles biased as a "U" device than any other bias condition.

The NAND strings in the unselected blocks are de-coupled from the global bit lines by ensuring that the respective block select devices, such as devices 173 and 189, remain off. Likewise, the NAND strings in the unselected blocks are de-coupled from the VDRAIN nodes by ensuring that the respective block select devices, such as device 175, also remain off. This may be achieved by driving V_{UNBSEL} to a voltage such as -1 volts, as shown. All the word lines 178 in the unselected blocks may be conveniently maintained at a $V_{WLUNSEL}$ voltage of ground.

Suitable ranges for each of the voltages described above are summarized in the following Table 2.

Table 2
Read Conditions

Signal	Range
V_{WL}	1V..1.5V
V_{WLPASS}	2V..2.5V
$V_{WLUNSEL}$	0V
V_{BSELB}	V_{DD}
V_{BSELD}	V_{DD}
V_{UNBSEL}	-3V..0V
V_{GBL}	1.5V..2.5V
V_{DADJ}	2V..3V
V_{DRAIN}	1.5V..2.5V
V_{DUNSEL}	Float

Program Operation

Referring now to Fig. 7, exemplary programming conditions are shown for this array structure. The selected memory cell device 169 in the selected NAND string is programmed by impressing a sufficiently high programming voltage (i.e., from gate-to-source) across the selected memory cell.

This may be accomplished by ensuring that the block select device is turned on to pass a low voltage from the global bit line 162 to the NAND string, and impressing a sufficiently high programming voltage on the selected word line 168. The passing word lines are driven to a high enough voltage to convey a low voltage on the global bit line to the selected memory cell device, but not high enough to unintentionally program the non-selected memory cells in the selected NAND string. To inhibit programming, the global bit line may be taken to a much higher voltage so that the gate-to-source voltage impressed across the selected

- 13 -

memory cell is less than that necessary to program the device. The passing word line voltage should be high enough to convey the bit line inhibit voltage to the selected memory cell device, as well.. One suitable set of program conditions includes driving the "global bit line" block select line V_{BSELB} to approximately 6 volts, and driving the "drain" block select line V_{BSELD} to approximately -1 volts, thus leaving the drain block select device 171 turned off. The V_{DRAIN} shared bias node is preferably left floating. The voltage of the global bit line 162 (i.e., V_{GBL}) is driven to approximately 0 volts to program, and driven alternatively to an inhibit voltage of approximately 6 volts to inhibit programming. The passing word line voltage V_{WLPASS} is approximately 4 volts so that at least most of the bit line inhibit voltage (i.e., at least approximately 5 volts) may be passed to the intermediate nodes in the selected NAND string. The voltage on the global bit line may be driven by a bit line driver circuit 190, which may be either directly coupled to the global bit line or may be shared among several global bit lines and coupled by decoding circuitry to a desired global bit line. Suitable driver and decoder circuits are well known in the art.

Referring briefly to Fig. 8, all the word lines in the selected block are driven to the V_{WLPASS} voltage (e.g., approximately 4 volts) to charge the intermediate nodes of the selected NAND string to a voltage at least close to the bit line inhibit voltage. Then the selected word line voltage V_{WL} is increased to a word line programming voltage of, for example, approximately 11 volts. If the V_{GBL} is 0, then substantially 11 volts is impressed across the selected memory cell device 169. Alternatively, if the V_{GBL} is driven to the inhibit voltage of, for example, approximately 6 volts, then only 5 volts is impressed across the selected memory cell device 169 and programming does not occur. Some coupling may occur from the selected word line to source/drain nodes near the selected word line, and result in a slightly less bias voltage during inhibit. Alternatively, the word lines may be driven to a voltage above the inhibit programming voltage while all the global bit lines and the V_{DADJ} are biased at the inhibit programming voltage to pass the full inhibit voltage to the drains within the NAND strings. Then, the selected word line may be driven upward to the programming voltage and the passing word lines reduced down to the passing word line voltage before the selected global bit lines are brought to ground. This achieves greater disturb protection at the expense of more complex operation.

The V_{DADJ} voltage is preferably driven to substantially the same voltage as the bit line inhibit voltage, so that the adjacent NAND string is biased in a similar inhibit condition as described above for the selected NAND string. The intermediate nodes in the adjacent NAND string are all biased at least at approximately 5 volts since every memory cell has a threshold voltage no higher than approximately 0 volts. As a result, the program disturb condition on the unselected devices 183 is approximately in a range from -1 volt to zero (depending upon the exact S/D voltage for a given device), and the program disturb condition for the half selected cell 185 is approximately 5-6 volts. Looking back to the selected NAND string, the program disturb condition on the "F" devices 167 is approximately 4 volts (the V_{WLPASS} voltage). These program disturb conditions, and the relative length of time a memory cell is exposed to such condition, are summarized in Table 3. The programming time (i.e., duration of time that the V_{WL} is driven to the word line programming voltage of, for example, 11 volts) may fall in the range from 1 to several tens of microseconds.

Table 3

PROGRAM DISTURB STRESS VOLTAGE AND TIME

CELL	VGS Voltage	STRESS TIME
H	5v	Shortest (e.g., typically ms)
F	4v	Medium (e.g., several ms)
U	-2 to 0v	Longest (e.g., tens of ms)

The block select device 171, on the drain end of the selected NAND string, is turned off during programming to avoid a leakage path through the selected NAND string that would pull V_{DRAIN} (node 172) to a data dependent state. Some strings might pull it high and some strings pull it low, obviously wasting power and potentially interfering with circuit operation.

The block select devices 171 and 187 have to be off by a slightly negative gate voltage (e.g., by a V_{BSELD} voltage of around -1 volts), and the S/D of the device would be at about 6 volts, in at least the adjacent strings and at some of the selected global bit lines. This puts a partial erase bias of approximately -7 volts gate-to-source on the block select device. If these block select devices are formed by the same process steps as the cell, these block select devices can get partially "erased" by this bias voltage applied during programming of a selected memory cell, which would slowly decrease the V_T of the block select devices into a negative region after a number of program cycles. Such a threshold voltage would prevent the block select device from being turned off with only a V_{BSELD} voltage of around -1 volts.

One could use extra processing to remove the charge storage dielectric layer (e.g., nitride) from the block select devices, but this adds complexity to the semiconductor process. Alternatively, a post-programming biasing condition is preferably added at the end of each program cycle, where the affected block select device is "programmed" a small amount to bring its V_T back up to its maximum of, for example, about 0 volts. This may be accomplished by returning all the word lines in the selected block (V_{WL} and V_{WLPASS}) back to ground (0 volts), taking the V_{GBL} and V_{DRAIN} to ground, and driving the V_{BSELD} to the programming voltage (e.g., about 10-11 volts) for a short time. For convenience, both block select signals may be driven to the programming voltage as there is little concern for over-programming the threshold of the block select devices. For an exemplary SONOS process described herebelow, the erase time is much longer than the programming time, so that even a relatively short "block select V_T adjust program time" is adequate to ensure that its V_T stays at its maximum. An exemplary duration of time for such a block select V_T adjust is approximately 1 μ s.

Suitable ranges for each of the voltages described above are summarized in the following Table 4.

Table 4
Program Conditions

Signal	Range
V_{WL}	7V..15V
V_{WLPASS}	2V..9V
$V_{WLUNSEL}$	Ground
V_{BSELB}	4V..10V
V_{BSELD}	-3V..0V
V_{UNBSEL}	-3V..0V
V_{GBL}	0V/4V..10V
V_{DADJ}	4V..10V
V_{DRAIN}	Float
V_{DUNSEL}	Float

5

Erase Operation

Referring now to Fig. 9, exemplary erase conditions are shown for this array structure. All the memory cells in a selected block are erased by impressing a sufficiently high magnitude negative gate-to-source voltage across each memory cell transistor. One suitable set of read conditions includes driving essentially the entire memory array to a VEE voltage of, for example, 10 volts. In particular, for the selected block, the global bit line voltage V_{GBL} , both block select lines V_{BSELB} and V_{BSELD} , and both shared bias nodes V_{DRAIN} and V_{DADJ} are all driven to an erase voltage. In the unselected blocks, the word lines $V_{WLUNSEL}$, the block select lines V_{UNBSEL} , and the shared drain nodes V_{DUNSEL} are also all driven to the erase voltage. Then, after allowing time for the intermediate nodes in the selected block to charge to substantially the erase voltage conveyed on the global bit lines and shared drain nodes, the word lines in the selected block are brought to ground (as shown in Fig. 10), thus impressing an erase bias across each memory cell in the block. As the erasing of the memory cells may proceed somewhat slowly compared to programming, the erase conditions time may advantageously be held for an erase time of up to tens of milliseconds.

The erase voltage, shown as VEE, is preferably set to an initial erase voltage at the start of erase, but then is slowly decreased to a final erase voltage over the duration of the erase cycle. This provides more complete erasure of the memory cells than does holding the erase voltage at a single value (by reducing the charge leakage through the "blocking oxide" closest to the polysilicon gate). The support circuitry for the array may be arranged to couple the various signals described to an internally generated VEE signal, which is then controlled to achieve a controlled pulse shape as depicted in Fig. 10. The falling edge of the VEE pulse is preferably controlled to fall no faster than the rate of fall of the various intermediate nodes in the NAND strings of the selected block just erased, which is determined by the leakage currents through the cells.

25

- 16 -

Alternatively, the word lines of the selected block could be returned to the VEE voltage, then the entire array brought back to ground by the falling edge of the VEE pulse.

While one block is presumed to be selected at a time for erasing in the above description, clearly more than one such block may be erased simultaneously, whether disposed on the same or on different levels of an array.

Suitable ranges for each of the voltages described above are summarized in the following Table 5.

Table 5
Erase Conditions

Signal	Range
V_{WL}	0V
V_{WLPASS}	0V
V_{BSELB}	6V..13V
V_{BSELD}	6V..13V
V_{UNBSEL}	6V..13V
V_{GBL}	6V..13V
V_{DADI}	6V..13V
V_{DRAIN}	6V..13V
V_{DUNSEL}	6V..13V

10

Referring now to Fig. 11, a three-dimensional memory array embodiment is shown which utilizes the array configuration described above. A respective NAND string is shown on each of eight memory levels, each depicted lying substantially in vertical alignment with each other. Each NAND string includes, for example, 16 series-connected memory cell transistors and a respective block select transistor at each end. All eight NAND strings share the same global bit line 162, and which are all connected by way of a "zia" 234 (the name suggesting a stacked via structure connecting more than one level in the z-direction). As indicated in Fig. 3, eight NAND strings on the opposite side of the global bit line zia 234 are also shared by the global bit line 162, for a total (for this embodiment) of 16 NAND strings served by one zia to one global bit line. The zia 234 is preferably connected to a wiring line on a wiring layer below the memory array, labeled R3 in the figure.

20

Similarly, all eight NAND strings share the same VDRAIN node 172 (i.e., the same shared bias node) which are all connected by way of a zia 236, which is preferably connected to an interconnection line on a wiring layer above the memory array, labeled TOP METAL in the figure. As described earlier, the VDRAIN nodes may also be shared laterally within a memory level by, for example, four adjacent NAND strings, resulting in 32 block select devices connected to the right side of the zia 236, rather than just the eight block select devices represented in Fig. 11. With connections to 32 block select devices per zia 236, such a VDRAIN zia may also be termed a "mast."

25

- 17 -

In contrast to the shared vertical connections for the global bit line and VDRAIN node, each of the two block select control signals, and each the plurality of word lines on each level is preferably unique to that level, and thus affords independent selection of each level. As described above, the various bias conditions for blocks within non-selected levels is the same as for non-selected blocks within the selected level. Each word line is routed vertically to a wiring layer below the array by a zia which is not electrically connected to other word lines on the same level, nor is it shared with word lines on other levels, although as is described below, one embodiment of such word line zias makes physical contact to small sacrificial features of word lines on intervening memory levels to improve the consistency of zia formation across all memory levels. Selecting a word line on just one memory level allows the smallest number of blocks to be biased for programming or reading, thus reducing the disturb time. If one was not limited by a desire to limit the disturb time, some area could be saved by sharing word line zias between word lines on more than one level (e.g., sharing between analogous word lines on two levels of the array). Likewise, the block select lines could then also be shared by more than one level of the array.

Fabrication Process

Referring now to Fig. 12, a flow diagram depicts an exemplary process for forming a memory level as described above. Such a flow may be used repeatedly to form multiple memory levels for a three-dimensional memory array, or may be used once to form a single memory level. Many other variations are contemplated, but the described flow is illustrative to point out various features and advantages of the invention.

The memory level is formed upon a starting material, as noted in step 262, which may include a semiconductor wafer already processed to include circuitry and wiring interconnections formed on a plurality of lower-level wiring layers formed above the substrate, or may include such a substrate already processed with memory array levels as described herein. At step 264 a relatively thick oxide is formed by growth, deposition, or other suitable method, to provide a dielectric isolation layer between the memory level and underlying structures. Such a dielectric layer may have a thickness in the range of 50 nm to several microns.

The collective steps 286 are invoked to form a plurality of channel stripes on the top surface of the dielectric layer. The individual steps involved include depositing an amorphous silicon layer, frequently known as an α -Si layer, at step 266. Alternatively, a polycrystalline silicon layer may be deposited. Such a silicon layer is preferably lightly-doped p-type polysilicon suitable for constructing N-channel SONOS devices, and is formed preferably to a thickness in the range from 5 nm to 200 nm. The silicon layer is preferably doped in-situ during the deposition process to result in activated dopants as deposited. Moreover, by doping in-situ, no separate implantation step is required to set the background concentration of the channel regions, thus potentially reducing manufacturing cost. Alternatively, the silicon layer may be deposited undoped and implanted. The silicon layer is preferably deposited in an amorphous state, and is polycrystallized during the subsequent heat treatment steps without requiring a specific step just to perform the crystallization.

At step 268, the α -Si layer is optionally implanted to adjust the eventual threshold voltage of the memory cell devices in the NAND strings, as well as the block select devices. In some preferred

- 18 -

embodiments, these devices are implanted to a depletion mode threshold voltage of approximately -2 to -3 volts. A depletion mode implant that is a slow diffuser, preferably antimony or arsenic, is implanted to shift the UV-erased, (i.e., minimum trapped charge in the nitride) V_T of the cell device to depletion mode.

At step 270, a photoresist layer is deposited and exposed with a channel mask to define photoresist features corresponding to the desired channel stripes. The α -Si layer is then etched at step 272, preferably using an anisotropic etch, to form the channel stripes, and the remaining photoresist removed at step 274. The resulting structure is depicted in Fig. 17, which shows an underlying substrate 372, a dielectric layer (oxide) 374, and two α -Si channel stripes 376 formed on the top surface of the oxide 374.

Next, at step 276, a charge storage dielectric layer, such as ONO dielectric stack, is formed on the channel stripes 376. Preferably, the ONO stack is formed on the sides of the channel stripes 376 as well as on the top surface, and also is formed on the top surface of the oxide 374 where exposed between channel stripes 376. Referring briefly to Fig. 13, an ONO stack may be formed by forming (at step 330) a first oxide layer having a thickness preferably in the range from 1.5 to 3.5 nm. Any of several techniques may be used, such as a Rapid Thermal Oxidation (RTO) in a pure oxygen environment, or in an oxygen environment diluted with nitrogen. Thermal oxidation in a furnace may also be employed to form this first oxide. As another alternative, an In-Situ Steam Generated Oxide (ISG) may be formed, as is described by Maitreyee Mahajani, et al., in the application entitled "Gate Dielectric Structures for Integrated Circuits and Methods for Making and Using Such Gate Dielectric Structures," now published as U.S. Patent Application Publication No. US 2003/0155582 A1.

Continuing with the formation of the ONO stack, a nitride layer is next formed (at step 332) having a thickness preferably in the range from 2.0 to 20.0 nm. Any of several techniques may be used, such as a Low Pressure Chemical Vapor Deposition (LPCVD) process to deposit stoichiometric silicon nitride. An oxynitride layer may also be formed rather than a nitride layer.

Continuing with the formation of the ONO stack, a top or "blocking" oxide layer is next formed (at step 334) having a thickness preferably in the range from 2.0 to 20.0 nm. Any of several techniques may be used, and preferably an HTO process is employed.

Referring back to Fig. 12, after formation of the ONO layer at step 276, the word line stripes are next formed by collective steps 288. The individual steps include depositing a gate material layer, at step 278. Such a layer preferably includes heavily-doped p-type (i.e., P+) polysilicon at least at the bottom of the gate material layer, as is described in more detail herebelow.

At step 280, a photoresist layer is deposited and exposed with a word line mask to define photoresist features corresponding to the desired word line stripes. The gate material layer is then etched at step 282, preferably using an anisotropic etch, to form the word line stripes, and the remaining photoresist removed at step 284. The resulting structure is depicted in Fig. 18, which shows an underlying substrate 372, a dielectric layer (oxide) 374, and a α -Si channel stripe 376 formed on the top surface of the oxide 374. A composite ONO layer 378 is shown on the top surface of the oxide 374 and the top and side of the channel stripe 376. A

word line stripe 380 is also shown conformally following the top surface of the ONO layer as it rises over the underlying channel strip 376.

Referring briefly to Fig. 14, a suitable gate material layer may be formed as a polysilicon/silicide/polysilicon stack. First, a layer of heavily-doped polysilicon is formed, preferably by in-situ doping during a deposition process to result in activated dopants as deposited, without requiring any
5 separate implantation operation. Alternatively, the polysilicon layer may be deposited undoped and implanted. A p-type gate layer is believed to result in improved erasure characteristics for the resultant SONOS devices (i.e., having less electron injection from the gate during erase), although N⁺ polysilicon may alternatively be employed. The gate doping concentration is preferably within the range of $10^{20} - 10^{21}$ atoms/cm³.

10 At step 342, a layer of titanium is deposited, followed by a titanium nitride layer, to form a low-resistance titanium silicide layer on top of the polysilicon layer during a subsequent RTA process (at step 344). Such an RTA is preferably carried out at a temperature in the range from 700-850 °C. Lastly, a final polysilicon layer is deposited on the TiN layer to form the sandwich or stack of gate material layers. As before, P⁺ polysilicon is preferred, although N⁺ polysilicon may also be employed.

15 Referring briefly to Fig. 16, the gate material layer may also be formed by, for example, depositing P⁺ (or N⁺) polysilicon (step 350), depositing a metal such as titanium or cobalt (step 352), then forming a silicide of the metal in a first RTA operation (step 354) and a second RTA operation (step 356), as is well known in the art.

20 Either of these gate material layers may then be masked and etched as described above to form a plurality of word line stripes over the ONO layer and channel stripes. As described below, the word line stripes may also be formed using a salicide procedure to create low resistance word lines rather than forming a silicide layer prior to gate etch.

Referring back to Fig. 12, after formation of the word line stripes, the flow continues by forming source/drain regions in the channel stripes in the exposed portions of the channel strips between word line
25 stripes. Such source/drain regions may be formed by collective steps 318, which may include the steps of implanting N⁻ regions (step 290), forming spacers (steps 292 and 294), and implanting N⁺ source/drain regions (step 296). The N⁺ source/drain implant conditions (and to a much lesser extent, the lightly-doped source/drain implant conditions) should be chosen to achieve a desired doping and junction depth of the source/drain regions, but should leave at least the bottom portion of the polysilicon gate structure doped P⁺
30 (i.e., still P⁺ doped at the ONO interface). In some embodiments, a silicide layer may be formed on the word line stripes and also on the source/drain regions, at step 298. Referring briefly to Fig. 16, a self-aligned silicide (i.e., a salicide) may be formed by depositing a metal such as titanium or cobalt (step 362), then forming a silicide of the metal in a first RTA operation (step 364), removing the unreacted metal by a wet etch (step 366), followed by a second RTA operation (step 368), as is well known in the art.

35 Again referring back to Fig. 12, after formation of the source/drain regions in the exposed portions of the channel stripes between word line stripes, the block select and memory cell transistor formation is

- 20 -

substantially complete, but forming electrical connections still remain. An interlevel dielectric layer, such as an oxide layer, is deposited at step 300 and planarized by chemical-mechanical polishing (CMP) at step 302. The resulting structure, in one embodiment, is depicted in Fig. 19, which shows a cross-section view which is “cut” longitudinally along a channel stripe 376. Three word line stripes (e.g., 380) are shown, having
5 sidewall spacers 391. Each transistor includes a shallow lightly-doped source/drain region 390 formed below each spacer 391, and a heavily-doped N⁺ source/drain region 392 is formed between each word line stripe. In this figure each word line stripe 380 is shown as a poly/silicide/poly stack, comprising a lower polysilicon layer 392, a silicide layer 396, and an upper polysilicon layer 398. An ONO layer 378 is shown between the word line stripe (i.e., the gate) and the transistor channel 376. The ONO layer is typically removed over the
10 source/drain regions 392 when forming the sidewall spacers, although any remaining ONO over the source/drain regions is harmless. An interlevel dielectric layer 400 is also shown filling the area between the word line stripes and covering the word line stripes. In an alternative method, the lightly-doped source/drain regions 390 may be absent, and only the more heavily-doped N⁺ source/drain regions 392 are actually present (and intentionally out-diffused to fall nearer the polysilicon gate edge. In yet another alternative method, the
15 sidewall spacers 391 and the lightly-doped source/drain regions 390 may be absent, and only the heavily-doped N⁺ source/drain regions 392 present. Moreover, the N⁺ regions 392 may be formed fully through and reach the bottom of the channel stripe 376.

In another embodiment, the resulting structure is depicted in Fig. 20, which also shows a cross-sectional view which is “cut” longitudinally along a channel stripe 376. Three word line stripes (e.g., 380) are shown
20 having sidewall spacers 391. Each transistor includes a shallow lightly-doped source/drain region 390 formed below each spacer 391, and a heavily-doped N⁺ source/drain region 392 formed in the channel stripe in “exposed” areas between each word line stripe. In this figure each word line stripe 380 is shown as a silicided polysilicon line, comprising a polysilicon layer 394 and a silicide layer 412. An ONO layer 378 is shown beneath the gate stripe. The ONO layer has been removed over the source/drain regions 392 by formation of
25 the sidewall spacers, and a silicide layer 414 formed on the surface of each source/drain region 392.

Referring now to Fig. 21, another embodiment is depicted showing a heavily-doped source/drain region 422 formed all the way through the channel stripe 376. A threshold implant layer 424 is shown directly below the ONO layer 378 underneath the gate (i.e., the word line stripe). Such an implant layer 424 may result from a depletion mode implant performed into the channel stripes to set the full-erased threshold voltage to a typical
30 value of from -2 to -3 volts. An interlevel dielectric layer 400 is shown, as before, as well as another interlevel dielectric layer 374 separating the memory level depicted from word line stripes 426 for the next lower memory level. Two cross-sectional views presented in subsequent figures are referenced in the figure, one cutting across the channel stripes in the transistor channel region of a memory cell (Fig. 22), and the other cutting across the channel stripes in the source/drain region 422 (Fig. 23).

35 Fig. 22, shows a cross-sectional view of the structure depicted in Fig. 20, which is “cut” longitudinally along a word line stripe 394. Three channel stripes (e.g., 440, 442) are shown, each having a threshold implant layer 424 formed in the upper portion of the channel stripe 376, and a remaining P⁻ doped region in the lower portion of the channel stripe. The ONO layer 378 is shown conformally disposed on the vertical edges of the

- 21 -

channel stripes, and on the top surfaces of the channel stripes and the interlevel dielectric layer 374. The word line stripe 394 is also preferably formed conformally on the ONO layer 378. By having the ONO layer and the word line stripe also disposed on the sides of each channel stripe, the effective electrical width of the transistor is wider than the horizontal dimension of the channel stripe, allowing the device to conduct more current for a given voltage drop across the device. In other contemplated embodiments, however, a dielectric material may fill the spaces between the channel stripes, and the gate stripes thus forming a transistor only on the top surface of the channel stripes. For example, a dielectric may be deposited to fill the spaces between channel stripes, and then planarized, such as by chemical-mechanical polishing (CMP). An ONO layer may then be formed on the planarized surface, and then the gate stripes formed on the surface of the ONO layer.

Again referring back to Fig. 12, after formation of the interlevel dielectric layer, electrical connections are formed to the underlying channel stripes and word line stripes. The collective steps 320 may then be employed to form plugged vias (herein sometimes referred to as "zias") in the interlevel dielectric layer to make connections to the channel stripes and word line stripes of the memory level. At step 304, a photoresist layer is deposited and exposed with a zia mask to define photoresist features corresponding to the desired zia openings. The interlevel dielectric 400 is then etched at step 306, preferably using an anisotropic etch. The zia etch preferably downward, preferably stopping on channel stripes (i.e., silicon) and word line stripes (i.e., silicon or silicide), and the remaining photoresist removed at step 308. A "plug implant" is performed into the openings to ensure low resistance contact to the underlying structures (step 310), frequently followed by a deposition of an adhesion layer material, such as TiN. Then a plug metal, such as tungsten, is deposited to fill the openings (step 312). The resulting structure is polished (step 314) to form zia plugs having a top surface coplanar with the top surface of the interlevel dielectric layer 400. Resulting structures are described herebelow in regard to later figures. At step 316, the α -Si layer for the next memory level may be formed, as described above.

Exemplary process specifications which are particularly suitable for fabricating the above structures are shown in Table 6 below.

Table 6

Parameter	Thickness/Dimensions
Channel silicon	50 – 2000 Å
ONO	150 Å
Dielectric spacer	200 – 500 Å
Gate poly	1000 – 2000 Å
Polycide sheet R	5 – 10 Ohm/Sq (500 – 250 Å CoSi ₂)
Channel "cide" sheet R	Not critical
Poly gate line/space	0.15 μ / 0.15 μ (for a 0.15 μ technology)
Channel line/space	0.15 μ / 0.15 μ (for a 0.15 μ technology)

The zias may be formed through an interlevel dielectric layer associated with just one memory level to make contact to channel stripes and word line stripes within that memory level. Such a flow requires a

- 22 -

separate zia mask for each memory level. In another embodiment, the zias may be formed to make contact simultaneously to structures on more than one memory level, thus requiring fewer zia masking operations.

Referring now to Fig. 24, a cross-sectional view of a multi-level zia structure 500 is shown. A single zia 510 is formed making a connection to a channel string 502 on level 3 (CH3), making a connection to a channel string 504 and a channel string 506 on level 4 (CH4), and making a connection to a channel string 508 on level 5 (CH5). The opening through the interlevel dielectric layer between CH4 and CH5, and the narrower opening through the interlevel dielectric layer between CH4 and CH3, may be formed using a single etch operation. Similarly, other operations, such as plug implants, adhesion layer deposition, and filling the zia with a metal, such as tungsten, may also be done once, and yet make connection between three levels rather than just two.

Referring now to Fig. 25, a layout is shown which may be used for this zia 510. While the zia 510 appears to overlap the CH3 feature 502 (thus violating a traditional via enclosure rule), only the portion of the zia feature 510 which lies between the two CH4 features 504 and 506 actually etches down to and reaches the CH3 feature 502. This zia structure is somewhat larger than a pure stacked via structure, but reduces the number of masks and processing steps significantly over a pure stacked via process which forms a separate plugged via at each memory level.

Referring briefly back to Fig. 3, a schematic was depicted representing an interleaved arrangement of NAND strings. A group of four NAND strings share a VDRAIN connection at one end of each NAND string, and make individual connection to a respective global bit line at the other end of each NAND string. Each contact to a global bit line is also shared by two NAND strings. Referring now to Fig. 26, an exemplary layout is depicted which corresponds to this schematic. The layouts of various channel stripe features are shown, along with various zias, although none of the block select lines and word lines are shown (if shown, they would run vertically in the dashed section in the middle portion of the figure). The layout may be viewed as representing the channel strings on all eight levels of a three-dimensional array. But for description purposes, the layout is labeled to point out three channel levels for consistency with Fig. 24. For example, the cross-hatched portion of the channel string feature labeled 520 corresponds to the CH3 feature 502 shown in Fig. 24. The cross-hatched portions of the channel string features labeled 526 and 528 correspond to the CH4 features 504 and 506, while the cross-hatched portion of the channel string feature labeled 522 corresponds to the CH5 feature 508. The layout feature 524 corresponds to the zia 510, as does feature 530. A shared VDRAIN "mast" 532 makes connection to the CH3, CH4, and CH5 levels as well. As can be appreciated, the structure depicted provides for very compact shared vertical connections to NAND strings on multiple levels, which is important in preserving array efficiency if the NAND strings are fairly short.

Referring now to Fig. 27, a cross-sectional view is depicted of an eight-level memory array, showing the multi-level zias ZIA1, ZIA2, and ZIA3 making vertical connections through all eight levels. For example, the zia 552 (of the first ZIA1 level) makes connection to the shared VDRAIN nodes on the CH1, CH2, and CH3 levels. The zia 554 makes connection to the CH1, CH2, and CH3 levels to form the shared global bit line contact, and further makes contact to an interconnect line 572 disposed on a lower-level routing layer R3,

- 23 -

which is routed to sense and driver circuitry for the global bit line (such as through via 574 to an even lower level interconnect layer). The zia 556 makes connection to the X1 X2 levels (the gate levels forming the word lines and block select lines) to form a connection from a word line level to an interconnect line 576 disposed the routing layer R3, which is routed to driver circuitry for the word line by way of via 578 to an even lower level interconnect layer.

The zias 552, 558, and 564 collectively form a shared VDRAIN "mast" 236 for all eight memory levels as depicted in Fig. 11, and provide connection to a top metal interconnect line 570 which preferably is routed parallel to the word lines. The zias 554, 560, and 566 collectively form a vertical global bit line contact 234 for all eight memory levels, also as depicted in Fig. 11. The zias 556, 562, and 568 provide a vertical connection from an X-level (e.g., X4) to an R3 interconnect layer. As described above, the word lines and block select lines for the various levels are not vertically connected like the shared drain and shared global bit line connections, but rather each word line and block select line is taken to an R3 interconnect line individually (in a logical sense). However, in a physical sense, small layout features on each X-level are preferably used to achieve the zia structure shown in Fig. 27 to better provide a more uniform process flow.

The surface 580 represents the top surface of zia 556, which is directly contacted by the next zia 562. Alternatively, a CH3 feature may be placed in this region so that the etch operation forming the hole for the zia 562 may stop on a silicon feature rather than exposing a tungsten feature (i.e., zia 556). Such a series connection through the CH3 feature is not believed to significantly affect the resistance of the zia stack. Likewise, a CH6 feature may be included at the bottom of each ZIA3 feature making connections to the X-layers. By so doing, all ZIA2 and ZIA3 zias may be processed to stop on the same CH6 level.

Referring now to Fig. 28, the multi-level zia concept may be easily extended to additional numbers of simultaneously connected levels. A single zia 599 is formed making a connection to a channel string 592 on the CH3 level, making a connection to a channel string 594 and a channel string 595 on the CH4 level, making a connection to a channel string 596 and a channel string 597 on the CH5 level, and making a connection to a channel string 598 on the CH6 level. The opening through the interlevel dielectric layer between CH6 and CH5, the narrower opening through the interlevel dielectric layer between CH5 and CH4, and the even narrower opening through the interlevel dielectric layer between CH4 and CH3, may all be formed using a single etch operation.

Referring now to Fig. 29, a cross-sectional view of another multi-level zia structure is depicted. A single 'chimney-like' zia 619 is formed making a connection to a channel string 612 on the CH3 level, making a connection to a channel string 614 and a channel string 615 on the CH4 level, making a connection to a channel string 616 and a channel string 617 on the CH5 level, and making a connection to a channel string 618 on the CH6 level. In this example, the side walls of the opening formed through the various interlevel dielectric layers are substantially vertical, and electrical connection is provided by the plugged zia mostly to the vertical "ends" of the CH4 and CH5 features. Such a chimney-like zia reduces layout area because the opening through each level is more uniform, and may reduce the number of masking steps required. Such a zia may also be useful to ensure that the zia etch does not completely etch through the intermediate channel

- 24 -

stripes which are preferably relatively thin. Although the contact resistance may be higher than other via or zia structures, such a chimney-like zia may be advantageously used for connecting the NAND strings to the global bit lines because the current through the NAND strings is frequently quite low.

5 An exemplary layout making use of such a zia 610 is depicted in Fig. 30. In this example, two adjacent NAND strings share a VDRAIN connection 636. A shared global bit line zia 634 makes a vertical connection between several coincidently-drawn channel strings 632. Several such zias 634 may be employed to provide connection to a channel strings on a large number of memory levels.

Additional Embodiments

10 As used herein, a series-connected NAND string includes a plurality of devices connected in series and sharing source/drain diffusions between adjacent devices. As used herein, a memory array may be a two dimensional (planar) memory array having a memory level formed in a substrate, or alternatively formed above the substrate. The substrate may either be a monocrystalline substrate, such as might include support circuitry for the memory array, or may be another type of substrate, which need not necessarily include support circuitry for the memory array. For example, certain embodiments of the invention may be
15 implemented utilizing a silicon-on-insulator (SOI) structure, and others utilizing a silicon-on-sapphire (SOS) structure. Alternatively, a memory array may be a three-dimensional array having more than one plane of memory cells (i.e., more than one memory level). The memory levels may be formed above a substrate including support circuitry for the memory array.

20 The present invention is contemplated for advantageous use with any of a wide variety of memory array configurations, including both traditional single-level memory arrays and multi-level (i.e., three-dimensional) memory arrays, and particularly those having extremely dense X-line or Y-line pitch requirements. Moreover, the invention is believed to be applicable to memory array having series-connected NAND strings which utilize modifiable conductance switch devices as memory cells, and is not to be limited to memory cells incorporating a charge storage dielectric. Such modifiable conductance switch devices are three-terminal
25 devices whose conductance between two of the terminals is modifiable, and further is "switched" or controlled by a signal on the third or control terminal, which is generally connected to the word lines (or to the block select lines, for some embodiments). The conductance may be modified during manufacture (e.g., by selective ion implantation using a masking layer), or may be modified post-manufacture (i.e., by programming using a tunneling current; by programming using a hot electron current, etc). The modifiable conductance frequently
30 is manifested as a modifiable threshold voltage, but may be manifested as a modifiable transconductance for some technologies.

As an example, a read-only memory (ROM) may be implemented using memory cell transistors arranged in a NAND string, where the respective threshold voltage of the memory cell transistors is determined during manufacture by any of the known techniques in the art (e.g., by selective ion implantation).

- 25 -

Another exemplary memory array may implement NAND strings of "polarizable dielectric devices" such as Ferroelectric devices, where the device characteristics are modified by applying a voltage on the gate electrode which changes the polarization state of the Ferroelectric gate material.

Yet another exemplary memory array may implement NAND strings of so-called "single electron" devices or "coulomb blockade" devices, where applied voltages on the word line change the state of electron traps formed by silicon nanoparticles or any quantum well structure in the channel region by which the conduction characteristics of the NAND string devices are changed. In some embodiments, the structure of the charge storage region of the NAND string devices could also be located in a nanometer sized (i.e., from 0.1 to 10 nanometers) silicon filament formed at the source or drain edges of the gate structure to modify the device characteristic. Other alternative embodiments may utilize an organic conducting layer for the channel region and form organic material devices in a NAND string whose conductive state is selectively changed by applying an appropriate voltage to the word lines.

Thus, while the embodiments described in detail above utilize charge storage dielectric such as an ONO stack, other memory cells such as ROM programmed threshold devices, polarizable dielectric devices, single electron or coulomb blockade devices, silicon filament charge storage devices, and organic material devices are also contemplated.

Moreover, while the embodiments described in detail above provide two conductance values corresponding to two different data states, and thus provide for storing one bit of information per memory cell, the invention may also be utilized to provide more than one bit per memory cell. For example, a charge storage dielectric may store charge in a number of localities. For some structures and programming techniques, the charge may be stored substantially uniformly along the device channel length when the programming mechanism acts uniformly along the channel (e.g., such as by tunneling), or the charge may be stored just at the source or drain edges when a programming mechanism such as hot carrier injection is used. Multiple bits of information could be stored in each NAND string device by locally storing charge at the source or drain edge in the case of hot electron programming, single electron memory devices or silicon filaments located at the source or drain edges. Multiple bits of information could also be stored by injecting several different levels of charge into the charge storage medium and associating different charge levels with different stored states.

In many of the embodiments described above, the block select devices are formed using the same process flow as the memory cells to reduce the number of process steps and device structures fabricated at each memory level. Thus the block select devices are formed having the same structure as the memory cells, although they may be sized differently. As used herein, such block select devices may be considered to be structurally substantially identical to the memory cell devices, even though the respective threshold voltages may be programmed or erased to different values.

It should be appreciated that the various bias voltages described herein, including negative voltages and high-voltage programming and erase voltages, may be received from external sources, or may be generated

- 26 -

internally using any of a number of suitable techniques. It should also be appreciated that the designations top, left, bottom, and right are merely convenient descriptive terms for the four sides of a memory array. The word lines for a block may be implemented as two inter-digitated groups of word lines oriented horizontally, and the global bit lines for a block may be implemented as two inter-digitated groups of global bit line oriented
5 vertically. Each respective group of word lines or global bit lines may be served by a respective decoder/driver circuit and a respective sense circuit on one of the four sides of the array. Suitable row and column circuits are set forth in "Multi-Headed Decoder Structure Utilizing Memory Array Line Driver with Dual Purpose Driver Device," now published as U.S. Patent Application Publication No. US 2003/0128581 A1.

10 Word lines may also be referred to as row lines or X-lines, and bit lines may also be referred to as column lines or Y-lines. The distinction between "word" lines and "bit" lines may carry at least two different connotations to those skilled in the art. When reading a memory array, it is assumed by some practitioners that word lines are "driven" and bit lines are "sensed." In this regard, X-lines (or word lines) are usually contemplated as being connected to the gate terminal of memory cell transistors forming the NAND strings.
15 The Y-lines (or bit lines) are usually contemplated as being connected to the source/drain terminal of the NAND strings. Secondly, the memory organization (e.g., data bus width, number of bits simultaneously read during an operation, etc.) may have some association with viewing one set of the two array lines more aligned with data "bits" rather than data "words." Consequently, the designations herein of X-lines, word lines, and row lines, and of Y-lines, bit lines, and column lines are illustrative of the various embodiments but should not
20 be viewed in a restrictive sense, but rather a more general sense.

As used herein, word lines and bit lines (e.g., including global bit lines) usually represent orthogonal array lines, and follow the common assumption in the art that word lines are driven and bit lines are sensed, at least during a read operation. Thus, the global bit lines of an array may also be referred to as sense lines of the array, and may also be referred to as simply global array lines (i.e., even though other array lines also exist).
25 No particular implication should be drawn as to word organization by use of such terms. Moreover, as used herein, a "global bit line" is an array line that connects to NAND strings in more than one memory block, but no particular inference should be drawn suggesting such a global bit line must traverse across an entire memory array or substantially across an entire integrated circuit.

The directionality of various array lines in the various figures is merely convenient for ease of
30 description of the two groups of crossing lines in the array. While word lines are usually orthogonal to bit lines, such is not necessarily required. Moreover, the word and bit organization of a memory array may also be easily reversed. As an additional example, portions of an array may correspond to different output bits of a given word. Such various array organizations and configurations are well known in the art, and the invention is intended to comprehend a wide variety of such variations.

35 The block diagrams herein may be described using the terminology of a single node connecting the blocks. Nonetheless, it should be appreciated that, when required by the context, such a "node" may actually represent a pair of nodes for conveying a differential signal, or may represent multiple separate wires (e.g., a

bus) for carrying several related signals or for carrying a plurality of signals forming a digital word or other multi-bit signal.

It will be appreciated by one skilled in the art that any of several expressions may be equally well used when describing the operation of a circuit including the various signals and nodes within the circuit, and no subtle inferences should be read into varied usage within this description. Frequently logic signals are named in a fashion to convey which level is the active level. The schematic diagrams and accompanying description of the signals and nodes should in context be clear. As use herein, two different voltages which are “substantially equal” to each other have respective values which are close enough to cause substantially the same effect under the context at issue. Such voltages may be assumed to fall within approximately 0.5 volts of each other, unless the context requires another value. For example, a passing voltage of 5 volts or 5.5 volts may cause substantially the same effect as compared to an inhibit bias voltage of 5 volts, and thus the 5.5 volt passing voltage may be considered to be substantially identical to the 5 volt inhibit voltage.

Based upon the teachings of this disclosure, it is expected that one of ordinary skill in the art will be readily able to practice the present invention. The descriptions of the various embodiments provided herein are believed to provide ample insight and details of the present invention to enable one of ordinary skill to practice the invention. Nonetheless, in the interest of clarity, not all of the routine features of the implementations described herein are shown and described. It should, of course, be appreciated that in the development of any such actual implementation, numerous implementation-specific decisions must be made in order to achieve the developer’s specific goals, such as compliance with application- and business-related constraints, and that these specific goals will vary from one implementation to another and from one developer to another. Moreover, it will be appreciated that such a development effort might be complex and time-consuming, but would nevertheless be a routine undertaking of engineering for those of ordinary skill in the art having the benefit of this disclosure.

For example, decisions as to the number of memory cells within each array or sub-array, the particular configuration chosen for word line and bit line pre-decoder and decoder circuits and bit line sensing circuits, as well as the word organization, are all believed to be typical of the engineering decisions faced by one skilled in the art in practicing this invention in the context of developing a commercially-viable product. As is well known in the art, various row and column decoder circuits are implemented for selecting a memory block, a NAND string within the selected block, and a memory cell within the selected NAND string based upon a address signals and possibly other control signals. Nonetheless, even though a mere routine exercise of engineering effort is believed to be required to practice this invention, such engineering efforts may result in additional inventive efforts, as frequently occurs in the development of demanding, competitive products.

While circuits and physical structures are generally presumed, it is well recognized that in modern semiconductor design and fabrication, physical structures and circuits may be embodied in computer readable descriptive form suitable for use in subsequent design, test or fabrication stages as well as in resultant fabricated semiconductor integrated circuits. Accordingly, claims directed to traditional circuits or structures may, consistent with particular language thereof, read upon computer readable encodings and representations

- 28 -

of same, whether embodied in media or combined with suitable reader facilities to allow fabrication, test, or design refinement of the corresponding circuits and/or structures. The invention is contemplated to include circuits, related methods or operation, related methods for making such circuits, and computer-readable medium encodings of such circuits and methods, all as described herein, and as defined in the appended
5 claims. As used herein, a computer-readable medium includes at least disk, tape, or other magnetic, optical, semiconductor (e.g., flash memory cards, ROM), or electronic medium and a network, wireline, wireless or other communications medium. An encoding of a circuit may include circuit schematic information, physical layout information, behavioral simulation information, and/or may include any other encoding from which the circuit may be represented or communicated.

10 The foregoing details description has described only a few of the many possible implementations of the present invention. For this reason, this detailed description is intended by way of illustration, and not by way of limitations. Variations and modifications of the embodiments disclosed herein may be made based on the description set forth herein, without departing from the scope and spirit of the invention. It is only the
15 following claims, including all equivalents, that are intended to define the scope of this invention. In particular, even though many embodiments are described in the context of a three-dimensional memory array of TFT memory cells, such limitations should not be read into the claims unless specifically recited. Moreover, the embodiments described above are specifically contemplated to be used alone as well as in various combinations. Accordingly, other embodiments, variations, and improvements not described herein are not necessarily excluded from the scope of the invention.

WHAT IS CLAIMED IS:

1. An integrated circuit comprising a memory array having at least one plane of memory cells formed above a substrate, said memory cells comprising modifiable conductance switch devices arranged in a plurality of series-connected NAND strings.
2. The integrated circuit as recited in claim 1 wherein the memory array comprises a three-
5 dimensional memory array having at least two planes of memory cells formed above the substrate.
3. The integrated circuit as recited in claim 1 wherein the memory cells comprise devices having a depletion mode threshold voltage at least some of the time.
4. The integrated circuit as recited in claim 2 wherein the memory cell devices have a depletion mode threshold voltage for at least one of two data states which is no greater than -0.5 volts.
- 10 5. The integrated circuit as recited in claim 2 wherein the memory cell devices have a respective depletion mode threshold voltage for each of two data states, each of which is no greater than 0 volts.
6. The integrated circuit as recited in claim 1 wherein the modifiable conductance switch devices comprise transistors having a respective threshold voltage which is determined during manufacture.
7. The integrated circuit as recited in claim 1 wherein the modifiable conductance switch devices
15 comprise transistors having a respective threshold voltage which is modifiable post-manufacture.
8. The integrated circuit as recited in claim 1 wherein the modifiable conductance switch devices comprise transistors having a charge storage dielectric.
9. The integrated circuit as recited in claim 8 wherein the charge storage dielectric of the memory cell transistors comprises an oxide-nitride-oxide (ONO) stack.
- 20 10. The integrated circuit as recited in claim 9 wherein the memory cell transistors have a depletion mode threshold voltage when the charge storage dielectric has a minimum stored charge level.
11. The integrated circuit as recited in claim 9 wherein the memory cell transistors have a first depletion mode threshold voltage corresponding to an erased data state and have a second depletion mode threshold voltage corresponding to a programmed data state.
- 25 12. The integrated circuit as recited in claim 9 wherein the memory cell devices have more than two nominal values of conductance, for storing more than one bit of data per memory cell.

- 30 -

13. The integrated circuit as recited in claim 1 wherein each string includes a first switch device at a first end thereof for coupling the string to an associated global array line.

14. The integrated circuit as recited in claim 13 wherein two NAND strings having word lines in common share a single global array line.

5 15. The integrated circuit as recited in claim 13 wherein each NAND string includes a second switch device at a second end thereof opposite the first end for coupling the string to an associated bias node.

16. The integrated circuit as recited in claim 15 wherein pairs of NAND strings are arranged so that a first control signal coupling one string of the pair to its associated global array line couples the other string of the pair to its associated bias node.

10 17. The integrated circuit as recited in claim 13 wherein the first switch device of each respective memory cell string comprises a transistor having a charge storage dielectric.

18. The integrated circuit as recited in claim 17 wherein the first switch device of each respective memory cell string has a depletion mode threshold voltage.

15 19. The integrated circuit as recited in claim 1 wherein the substrate comprises a monocrystalline substrate including circuitry which is coupled to the memory array.

20. The integrated circuit as recited in claim 1 wherein the substrate comprises a polycrystalline substrate.

21. The integrated circuit as recited in claim 1 wherein the substrate comprises an insulating substrate.

20 22. The integrated circuit as recited in claim 13 wherein the switch devices and memory cell devices forming each NAND string are structurally substantially identical.

23. The integrated circuit as recited in claim 2 wherein NAND strings on more than one memory level are respectively coupled to global array lines disposed on fewer levels than said more than one memory level.

25 24. The integrated circuit as recited in claim 2 wherein a respective plurality of NAND strings on each of at least two memory levels are coupled to a single global array line disposed on a single level of the integrated circuit.

- 31 -

25. The integrated circuit as recited in claim 24 wherein at least two NAND strings on each of at least two memory planes make contact to an associated global array line by way of a shared zia.

26. An integrated circuit comprising:

a memory array having at least one plane of memory cells arranged in a plurality of series-connected
5 NAND strings;

wherein each respective NAND string includes a first switch device at one end thereof for coupling
the respective NAND string to an associated global array line, and further includes a second
switch device at the other end thereof for coupling the respective NAND string to an
associated bias node;

10 wherein the first switch device for a first NAND string and the second switch device for a second
NAND string are responsive to a first control signal, and the second switch device for the
first NAND string and the first switch device for the second NAND string are responsive to
a second control signal; and

wherein the first and second NAND strings share word lines in common.

15 27. The integrated circuit as recited in claim 26 wherein:

the memory array comprises a two-dimensional memory array having one plane of memory cells
formed in a substrate.

28. The integrated circuit as recited in claim 26 wherein:

20 the memory array comprises a three-dimensional memory array having more than one plane of
memory cells formed above a substrate.

29. The integrated circuit as recited in claim 26 wherein:

the memory cells comprise transistors having a charge storage dielectric.

30. The integrated circuit as recited in claim 26 wherein:

25 the memory cells comprise transistors having a respective threshold voltage which is modifiable post-
manufacture.

31. The integrated circuit as recited in claim 26 wherein:

the first and second switch devices of a given NAND string are structurally substantially identical to
the memory cell transistors of the given NAND string.

32. The integrated circuit as recited in claim 26 wherein:

30 the memory cell transistors of a given NAND string have a depletion mode threshold voltage for at
least one of two data states.

33. The integrated circuit as recited in claim 32 wherein:

- 32 -

the depletion mode threshold voltage for at least one of two data states is more negative than about --
0.5 volts.

34. The integrated circuit as recited in claim 26 wherein the memory array is arranged in a plurality of blocks, a first memory block of said plurality of memory blocks comprising:

- 5 a first bias node;
a second bias node;
a plurality of global bit lines traversing across the first block in a first direction;
a plurality of word lines traversing across the first block in a second direction different than the first
direction;
10 a first block select line traversing across the first block generally parallel to and disposed on one side
of the plurality of word lines;
a second block select line traversing across the first block generally parallel to and disposed on the
other side of the plurality of word lines; and
a plurality of series-connected NAND strings, each comprising a first block select device responsive
15 to the first block select line, a plurality of memory cell devices each responsive to a
respective one of the plurality of word lines, and a second block select device responsive to
the second block select line;
wherein the first block select device of each of a first group of the NAND strings is respectively
coupled to a respective one of the plurality of global bit lines, and the first block select
20 device of each of a second group of the NAND strings is respectively coupled to the first
bias node; and
wherein the second block select device of each of the first group of the NAND strings is respectively
coupled to the second bias node, and the second block select device of each of the second
group of the NAND strings is respectively coupled to a respective one of the plurality of
25 global bit lines.

35. The integrated circuit as recited in claim 34 wherein:
pairs of NAND strings are coupled to the same global bit line, each such pair including a NAND
string from each of the first and second groups of NAND strings, thereby providing for a
global bit line pitch which is half that of the NAND strings.

36. The integrated circuit as recited in claim 34 wherein:
30 more than one physically adjacent NAND strings of the first memory block share a contact to the first
or second bias nodes.

37. The integrated circuit as recited in claim 34 wherein:
each NAND string of the first memory block contacts its associated global bit line by way of a via
35 which is shared by a corresponding NAND string of another memory block having different
word lines.

- 33 -

38. The integrated circuit as recited in claim 34 further comprising:

a second memory block disposed to one side of the first memory block, and sharing the first bias node and the plurality of global bit lines with the first memory block, said plurality of global bit lines traversing across the second block in the first direction, said second memory block
5 respectively comprising

a third bias node;

a second plurality of word lines traversing across the block in the second direction;

a third block select line traversing across the block generally parallel to and disposed on one side of the second plurality of word lines;

10 a fourth block select line traversing across the block generally parallel to and disposed on the other side of the second plurality of word lines; and

a second plurality of series-connected NAND strings, each respectively comprising a first block select device responsive to the third block select line, a plurality of memory cell devices each responsive to a respective one of the second plurality of word lines, and a second block select device responsive to the fourth block select line;

15 wherein the respective second block select device of each of a first group of the second plurality of NAND strings is respectively coupled to a respective one of the plurality of global bit lines, and the respective second block select device of each of a second group of the second plurality of NAND strings is respectively coupled to the first bias node; and

20 wherein the respective first block select device of each of the first group of the second plurality of NAND strings is respectively coupled to the third bias node, and the respective first block select device of each of the second group of the second plurality of NAND strings is respectively coupled to a respective one of the plurality of global bit lines.

39. The integrated circuit as recited in claim 38 wherein:

25 the first block select device of each of the first group of the NAND strings of the first memory block is respectively coupled to the respective one of the plurality of global bit lines by way of a contact which is shared by the respective second block select device of each of the first group of the second plurality of NAND strings for the second memory block.

40. The integrated circuit as recited in claim 34 wherein the memory array comprises a three-
30 dimensional memory array having more than one memory levels formed above a substrate, said integrated circuit further comprising:

a third memory block disposed on a level of the memory array different than that of the first memory block, said first and third memory blocks sharing the plurality of global bit lines, the first bias node, and the second bias node, said third memory block respectively comprising

35 a third plurality of word lines traversing across the block in the second direction;

a fifth block select line traversing across the block generally parallel to and disposed on one side of the third plurality of word lines;

- 34 -

a sixth block select line traversing across the block generally parallel to and disposed on the other side of the third plurality of word lines; and

a third plurality of series-connected NAND strings, each respectively comprising a first block select device responsive to the fifth block select line, a plurality of memory cell devices each responsive to a respective one of the third plurality of word lines, and a second block select device responsive to the sixth block select line;

wherein the respective first block select device of each of a first group of the third plurality of NAND strings is respectively coupled to a respective one of the plurality of global bit lines, and the respective first block select device of each of a second group of the third plurality of NAND strings is respectively coupled to the first bias node; and

wherein the respective second block select device of each of the first group of the third plurality of NAND strings is respectively coupled to the second bias node, and the respective second block select device of each of the second group of the third plurality of NAND strings is respectively coupled to a respective one of the plurality of global bit lines.

41. The integrated circuit as recited in claim 40 wherein:
each NAND string of the first memory block contacts its associated global bit line by way of a via which is shared by a corresponding NAND string of the third memory block.

42. The integrated circuit as recited in claim 38 wherein:
each of the first group of NAND strings of the first memory block contacts its associated global bit line by way of a via which is shared by a NAND string of the second memory block.

43. The integrated circuit as recited in claim 34 wherein:
the memory cell devices comprise transistors having a charge storage dielectric.

44. The integrated circuit as recited in claim 34 wherein:
the memory cell devices comprise transistors having a respective threshold voltage which is modifiable post-manufacture.

45. The integrated circuit as recited in claim 43 wherein:
the first and second block select devices of a given NAND string are structurally identical to the memory cell transistors of the given NAND string.

46. The integrated circuit as recited in claim 43 wherein:
the memory cell transistors of a given NAND string have a depletion mode threshold voltage for at least one of two data states.

- 35 -

47. A method for operating an integrated circuit, said integrated circuit comprising a memory array having at least one plane of memory cells, said memory cells arranged in a plurality of series-connected NAND strings, said method comprising:

selecting a block of the array;

- 5 driving a first block select line for the selected block to a first block select voltage, said first block select line for coupling a first end of a first NAND string to a first global array line, and for coupling a first end of a second NAND string to a first bias node, said second NAND string sharing the same word lines as the first NAND string;
- 10 driving a second block select line for the selected block to a second block select voltage, said second block select line for coupling a second end of the first NAND string to a second bias node, and for coupling a second end of the second NAND string to the first global array line;
- driving unselected word lines of the selected block to an unselected world line voltage;
- driving at least one selected word line to a selected word line voltage;
- 15 impressing a first bias condition on the first bias node;
- impressing a second bias condition on the second bias node; and
- impressing a global array line bias voltage on the first global array line.

48. The method as recited in claim 47 wherein:

- 20 the first block select voltage, the second block select voltage, the global array line bias voltage, the first bias condition, and the second bias condition are chosen to couple the first end of the first NAND string to the first global array line, to couple the first end of the second NAND string to the first bias node, to couple the second end of the first NAND string to the second bias node, and to couple the second end of the second NAND string to the first global array line.

49. The method as recited in claim 48 wherein:

- 25 the unselected word line voltage is substantially equal to the first and second block select voltages; the selected word line voltage is lower than the unselected word line voltage; and the at least one selected word line is driven to the unselected word line voltage for a time before being driven to the selected word line voltage.

50. The method as recited in claim 49 wherein:

- 30 the global array line bias voltage, the first bias condition, and the second bias condition are chosen to impress a non-zero bias voltage across the first NAND string but not across the second NAND string.

51. The method as recited in claim 49 wherein:

- 35 the unselected word line voltage, the global array line bias voltage, the first bias condition, and the second bias condition are all chosen to be a substantially identical positive erase voltage; the selected word line voltage is chosen to be substantially less than the erase voltage; and

- 36 -

all word lines of the selected block are selected, but are driven to the unselected word line voltage for a time before being driven to the selected word line voltage.

52. The method as recited in claim 47 wherein:

5 the first block select voltage, the second block select voltage, the global array line bias voltage, the first bias condition, and the second bias condition are chosen to couple the first end of the first NAND string to the first global array line, to couple the first end of the second NAND string to the first bias node, but to de-couple the second end of the first NAND string from the second bias node, and to de-couple the second end of the second NAND string from the first global array line.

10 53. The method as recited in claim 52 wherein:

the unselected word line voltage is within three volts of the first block select voltage;
the selected word line voltage is higher than the unselected word line voltage; and
the at least one selected word line is driven to the unselected word line voltage before being driven to the selected word line voltage.

15 54. A method for operating an integrated circuit memory array having at least one plane of memory cells formed above a substrate, said memory cells comprising modifiable conductance switch devices arranged in a plurality of series-connected NAND strings, said method comprising:

coupling a respective first end of two NAND strings to a global array line, both NAND strings sharing word lines in common; and
20 biasing the respective opposite ends of the two NAND strings to respective different voltages, such that a substantially greater bias voltage is developed across one of the NAND strings than the other.

55. The method as recited in claim 54 wherein:

the modifiable conductance switch devices comprise transistors having a charge storage dielectric.

25 56. The method as recited in claim 54 wherein:

the modifiable conductance switch devices comprise transistors having a respective threshold voltage which is modifiable post-manufacture.

57. The method as recited in claim 55 further comprising:

30 selecting a block of the array, a NAND string within the selected block, and a memory cell within the selected NAND string;
coupling a first end of the selected NAND string to a global bit line and coupling a second end of the selected NAND string opposite the first end to a second shared bias node;

- 37 -

coupling a first end of a second NAND string to a first bias node, said second NAND string having word lines in common with the selected NAND string, and coupling a second end of the second NAND string opposite the first end to the global bit line;

impressing a first bias voltage onto the global bit line and a second bias voltage onto the second bias node to thereby impress a differential voltage across the selected NAND string;

5 impressing a read voltage onto a word line of the selected cell, said read voltage chosen to cause greater current flow through a respective cell for one data state than for a second data state;

impressing a passing voltage onto respective word lines of non-selected cells in the selected NAND string, said passing voltage chosen to cause substantially the same current to flow through a

10 respective cell for both of the two data states;

impressing the first bias voltage onto the first shared bias node, thereby maintaining a substantially zero volt bias across the second NAND string; and

sensing current flow through the selected NAND string and onto the global bit line.

58. The method as recited in claim 57 further comprising:

15 driving a first block select line to a first block select voltage to simultaneously couple the first end of the selected NAND string to the global bit line and to couple the first end of the second NAND string to the first bias node; and

driving a second block select line to a second block select voltage to simultaneously couple the second end of the selected NAND string to the second shared bias node and to couple the

20 second end of the second NAND string to the global bit line.

59. The method as recited in claim 57 wherein:

the passing voltage is substantially equal to the first bias voltage.

60. The method as recited in claim 57 wherein:

the read voltage is less than both the first and second bias voltages.

25 61. The method as recited in claim 57 wherein:

all word lines of the selected block are initially driven to the passing voltage, then the selected word line is driven to the read voltage.

62. The method as recited in claim 57 wherein:

substantially no bias voltage is impressed across memory cells in the second NAND string.

30 63. The method as recited in claim 54 further comprising:

selecting a block of the array, a NAND string within the selected block, and a memory cell within the selected NAND string;

- 38 -

coupling one end of the selected NAND string, and one end of a second NAND string, to a selected global bit line, said second NAND string sharing word lines in common with the selected NAND string;

impressing a read bias voltage across the selected NAND string;

5 impressing substantially no bias voltage across the second NAND string;

impressing a read voltage onto a word line associated with the selected cell, said read voltage chosen to cause greater current flow through a respective cell for one data state than for a second data state;

10 impressing a passing voltage onto respective word lines of non-selected cells in the selected NAND string, said passing voltage chosen to cause substantially the same current to flow through a respective cell for both of the two data states; and

sensing current flow through the selected NAND string onto the selected global bit line to determine the data state of the selected memory cell.

64. The method as recited in claim 63 wherein:

15 the passing voltage is chosen within the range of the bias voltage across the selected NAND string, thereby biasing non-selected memory cells in the selected NAND string with a voltage thereacross that is less than the bias voltage.

65. The method as recited in claim 63 further comprising:

20 ensuring that other NAND strings sharing the selected global bit line are de-coupled from the selected global bit line.

66. The method as recited in claim 63 wherein:

the modifiable conductance switch devices comprise transistors having a charge storage dielectric.

67. The method as recited in claim 63 wherein:

25 the modifiable conductance switch devices comprise transistors having a respective threshold voltage which is modifiable post-manufacture.

68. A method for programming a memory cell in a memory array, said memory array having at least one plane of memory cells formed above an integrated circuit substrate, said memory cells comprising modifiable conductance switch devices arranged in a plurality of series-connected NAND strings, said method comprising:

30 selecting a block of the array, a NAND string within the selected block, and a memory cell within the selected NAND string;

coupling a first end of the selected NAND string to a global bit line;

coupling a first end of a second NAND string to a first bias node, said second NAND string having word lines in common with the selected NAND string;

35 de-coupling a second end of the selected NAND string from a second shared bias node;

- 39 -

de-coupling a second end of the second NAND string from the global bit line;
impressing a bit line programming voltage onto the global bit line to program the selected memory
cell or a bit line inhibit voltage to inhibit programming of the selected memory cell;
impressing an inhibit bias voltage onto the first bias node;
5 driving unselected word lines of the selected block to a word line passing voltage; and
driving the selected word line to a word line programming voltage for a duration of time, to
conditionally program the selected memory cell in accordance with the impressed global bit
line voltage.

69. The method as recited in claim 68 further comprising:
10 driving the selected word line to the word line passing voltage for a time before driving the selected
word line to the word line programming voltage.

70. The method as recited in claim 68 wherein:
the inhibit bias voltage is substantially the same as the bit line inhibit voltage.

71. The method as recited in claim 68 further comprising:
15 floating the second bias node.

72. The method as recited in claim 68 further comprising:
driving a first block select line to a first block select voltage to simultaneously couple the first end of
the selected NAND string to the global bit line and to couple the first end of the second
NAND string to the first bias node; and
20 driving a second block select line to a second block select voltage to simultaneously de-couple the
second end of the selected NAND string from the second shared bias node and to de-couple
the second end of the second NAND string from the global bit line.

73. The method as recited in claim 68 wherein:
the passing word line voltage is within about 2 volts of the inhibit bias voltage.

74. The method as recited in claim 68 further comprising:
25 after programming the selected memory cell, then programming the first and second block select
devices in the first and second NAND strings to counteract any partial erase which may have
occurred during programming of the selected memory cell.

75. The method as recited in claim 68 wherein:
30 the modifiable conductance switch devices comprise transistors having a charge storage dielectric.

76. The method as recited in claim 68 wherein:

- 40 -

the modifiable conductance switch devices comprise transistors having a respective threshold voltage which is modifiable post-manufacture.

77. A method for erasing a block in a memory array, said memory array having at least one plane of memory cells formed above an integrated circuit substrate, said memory cells comprising modifiable
5 conductance switch devices arranged in a plurality of series-connected NAND strings, said method comprising:

selecting a block of the array;

coupling a respective first end of each NAND string in the selected block to an associated global bit
line;

10 coupling a respective second end of each NAND string in the selected block to an associated bias node;

impressing a source/drain erase voltage onto the global bit lines and the bias nodes associated with
the selected block; and

15 impressing a word line erase voltage onto all word lines of the selected block for an erase time to erase the block.

78. The method as recited in claim 77 further comprising:

driving the word lines in the selected block to the source/drain erase voltage for a time before driving
the word lines in the selected block to the word line erase voltage.

79. The method as recited in claim 78 further comprising:

20 driving all word lines and bias nodes for non-selected blocks to the source/drain erase voltage for the duration of the erase time.

80. The method as recited in claim 77 further comprising:

25 decreasing the source/drain erase voltage over the duration of the erase time from an initial source/drain erase voltage to a final source/drain erase voltage that is lower than the initial source/drain erase voltage.

81. The method as recited in claim 80 wherein:

the initial source/drain erase voltage is within the range from approximately 6 to 13 volts.

82. The method as recited in claim 77 wherein:

the word line erase voltage is substantially equal to ground.

30 83. The method as recited in claim 77 wherein:

the modifiable conductance switch devices comprise transistors having a charge storage dielectric.

84. The method as recited in claim 77 wherein:

- 41 -

the modifiable conductance switch devices comprise transistors having a respective threshold voltage which is modifiable post-manufacture.

85. A computer readable medium encoding an integrated circuit, said encoded integrated circuit comprising a memory array having at least one plane of memory cells formed above a substrate, said memory cells comprising modifiable conductance switch devices arranged in a plurality of series-connected NAND strings.

86. The computer readable medium as recited in claim 85 wherein the encoded integrated circuit memory array comprises a three-dimensional memory array having at least two planes of memory cells.

87. The computer readable medium as recited in claim 85 wherein the encoded modifiable conductance switch devices comprise transistors having a charge storage dielectric.

88. The computer readable medium as recited in claim 85 wherein each encoded NAND string includes a first switch device at a first end thereof for coupling the string to an associated global array line.

89. The computer readable medium as recited in claim 88 wherein two NAND strings having word lines in common share a single global array line.

90. The computer readable medium as recited in claim 88 wherein each NAND string includes a second switch device at a second end thereof opposite the first end for coupling the string to an associated bias node.

91. The computer readable medium as recited in claim 90 wherein pairs of NAND strings are arranged so that a first control signal coupling one string of the pair to its associated global array line couples the other string of the pair to its associated bias node.

92. The computer readable medium as recited in claim 88 wherein the first switch device of each respective NAND string comprises a transistor having a charge storage dielectric.

93. The computer readable medium as recited in claim 92 wherein the first switch device of each respective memory cell string has a depletion mode threshold voltage.

94. The computer readable medium as recited in claim 88 wherein the switch devices and memory cell devices forming each NAND string are structurally substantially identical.

- 42 -

95. The computer readable medium as recited in claim 86 wherein NAND strings on more than one memory level are respectively coupled to global array lines disposed on fewer levels than said more than one memory level.

5 96. A computer readable medium encoding an integrated circuit layout, said encoded integrated circuit layout comprising:
a first memory block comprising
a plurality of channel stripes running in a first direction;
a plurality of gate stripes running in a second direction different than the first direction, said gate stripes forming a plurality of word lines, a first block select line running generally parallel to
10 and disposed on one side of the plurality of word lines, and a second block select line running generally parallel to and disposed on the other side of the plurality of word lines;
a plurality of global bit lines traversing across the first block in the first direction;
wherein said plurality of gate stripes and said plurality of channel stripes together form a plurality of series-connected NAND strings, each comprising a first block select device coupled to the
15 first block select line, a plurality of memory cell devices each coupled to a respective one of the plurality of word lines, and a second block select device coupled to the second block select line;
wherein the first block select device of each of a first group of the NAND strings is respectively coupled to a respective one of the plurality of global bit lines, and the first block select device of each of a second group of the NAND strings is respectively coupled to a first bias
20 node; and
wherein the second block select device of each of the first group of the NAND strings is respectively coupled to a second bias node, and the second block select device of each of the second group of the NAND strings is respectively coupled to a respective one of the plurality of
25 global bit lines.

97. The computer readable medium as recited in claim 96 wherein:
pairs of NAND strings are coupled to the same global bit line, each such pair including a NAND
string from each of the first and second groups of NAND strings, thereby providing for a
global bit line pitch which is half that of the NAND strings.

30 98. The computer readable medium as recited in claim 96 wherein:
more than one physically adjacent NAND strings of the first memory block share a contact to the first or second bias nodes.

99. The computer readable medium as recited in claim 96 wherein:
the first group and second group of NAND strings are 2:1 interleaved.

35 100. The computer readable medium as recited in claim 96 wherein:

- 43 -

the first group and second group of NAND strings are 4:1 interleaved.

101. The computer readable medium as recited in claim 96 wherein:
each NAND string of the first memory block contacts its associated global bit line by way of a via
which is shared by a corresponding NAND string of another memory block having different
word lines.

5

102. The computer readable medium as recited in claim 96 further comprising:
a second memory block disposed to one side of the first memory block, and sharing the first bias node
and the plurality of global bit lines with the first memory block, said plurality of global bit
lines traversing across the second block in the first direction.

10

103. The computer readable medium as recited in claim 102 wherein:
each of the first group of NAND strings of the first memory block contacts its associated global bit
line by way of a via which is shared by a NAND string of the second memory block.

104. The computer readable medium as recited in claim 96 wherein the channel stripes are formed on
a dielectric layer disposed above a substrate for the integrated circuit.

15

105. The computer readable medium as recited in claim 96 wherein the memory array comprises a
three-dimensional memory array having more than one memory levels formed above a substrate, said
integrated circuit further comprising:

a third memory block disposed on a level of the memory array different than that of the first memory
block, said first and third memory blocks sharing the plurality of global bit lines, the first
bias node, and the second bias node.

20

106. The computer readable medium as recited in claim 105 wherein:
each NAND string of the first memory block contacts its associated global bit line by way of a via
which is shared by a corresponding NAND string of the third memory block.

25

107. The computer readable medium as recited in claim 96 wherein:
the first and second block select devices of a given NAND string are structurally identical to the
memory cell transistors of the given NAND string.

108. A memory cell comprising a TFT SONOS transistor having a depletion-mode threshold voltage
for at least one of two data states.

30

109. A memory cell as recited in claim 108 wherein the depletion mode threshold voltage for at least
one data state is no greater than -0.5 volts.

110. A memory cell as recited in claim 108 wherein the depletion mode threshold voltage for each of two data states is no greater than 0 volts.

111. A method for manufacturing an integrated circuit memory array, said method comprising the steps of:

- 5 forming a plurality of channel stripes on a dielectric layer above the substrate, said stripes running in a first direction;
forming a charge storage dielectric layer on the channel stripes;
forming a plurality of gate stripes on the charge storage dielectric layer, said gate stripes running in a second direction different than the first direction;
10 forming heavily-doped regions in the channel stripes between the gate stripes; and
forming an interlevel dielectric layer above the gate stripes.

112. The method as recited in claim 111 further comprising the steps of:

forming plugged vias through the interlevel dielectric layer, said vias connecting to channel stripes and gate stripes on at least one underlying memory level.

- 15 113. The method as recited in claim 112 wherein the step for forming plugged vias comprises:
forming openings in the interlevel dielectric layer to expose a portion of at least one channel stripe or gate stripe therebelow;
filling the openings with a conductive metal; and
planarizing the resultant structure to form plugged vias having a top surface in common with a top
20 surface of the interlevel dielectric layer.

114. The method as recited in claim 111 wherein:

the charge storage dielectric layer is formed conformally on the plurality of channel stripes; and
the plurality of gate stripes are formed conformally over the plurality of channel stripes.

- 25 115. The method as recited in claim 111 wherein the step for forming the plurality of channel stripes comprises:

depositing a layer of silicon on the underlying dielectric layer; and
masking and etching the silicon layer to form the plurality of channel stripes.

116. The method as recited in claim 115 further comprising the step of:

- 30 implanting the deposited layer of silicon to provide a depletion mode threshold voltage for transistors subsequently formed in the channel stripes.

117. The method as recited in claim 115 wherein the deposited layer of silicon comprises an amorphous silicon layer.

- 45 -

118. The method as recited in claim 115 wherein the deposited layer of silicon comprises a polycrystalline silicon layer.

119. The method as recited in claim 115 wherein the deposited layer of silicon is doped in-situ during deposition.

5 120. The method as recited in claim 111 wherein the charge storage dielectric layer comprises silicon, oxygen and nitrogen.

121. The method as recited in claim 120 wherein the charge storage dielectric layer comprises a silicon oxide/silicon nitride/silicon oxide (ONO) stack.

10 122. The method as recited in claim 111 further comprising the step of forming spacers on sidewalls of the gate stripes before forming the heavily-doped regions in the channel stripes.

123. The method as recited in claim 122 further comprising the step of forming lightly-doped source/drain regions in the channel stripes before forming the spacers.

124. The method as recited in claim 111 further comprising the step of forming a silicide layer on or within the gate stripes.

15 125. The method as recited in claim 124 wherein the silicide layer is formed on a deposited polysilicon layer before etching the polysilicon layer to form the gate stripes.

126. The method as recited in claim 124 wherein the silicide layer is formed on the gate stripes after forming the heavily-doped regions, and wherein the silicide layer is also formed on the heavily-doped regions of the channel stripes.

20 127. An integrated circuit including a three-dimensional memory array having more than one memory level of memory cells, each memory level of said integrated circuit comprising:
a plurality of channel stripes on a dielectric layer above the substrate, said stripes running in a first direction;
a charge storage dielectric layer on the channel stripes;
25 a plurality of gate stripes on the charge storage dielectric layer, said gate stripes running in a second direction different than the first direction;
heavily-doped regions in the channel stripes between the gate stripes; and
an interlevel dielectric layer above the gate stripes.

128. The integrated circuit as recited in claim 127 wherein the integrated circuit further comprises:

- 46 -

plugged vias formed through at least one interlevel dielectric layer making contact to portions of channel strings and gate strings therebelow.

129. The integrated circuit as recited in claim 127 wherein the charge storage dielectric layer comprises silicon, oxygen and nitrogen.

5 130. The integrated circuit as recited in claim 129 wherein the charge storage dielectric layer comprises a silicon oxide/silicon nitride/silicon oxide (ONO) stack.

131. The integrated circuit as recited in claim 127 further comprising spacers on sidewalls of the gate stripes.

10 132. The integrated circuit as recited in claim 131 further comprising lightly-doped source/drain regions in the channel stripes.

133. The integrated circuit as recited in claim 127 further comprising a silicide layer formed on or within the gate stripes.

134. The integrated circuit as recited in claim 133 further comprising a silicide layer formed on the heavily-doped regions of the channel stripes.

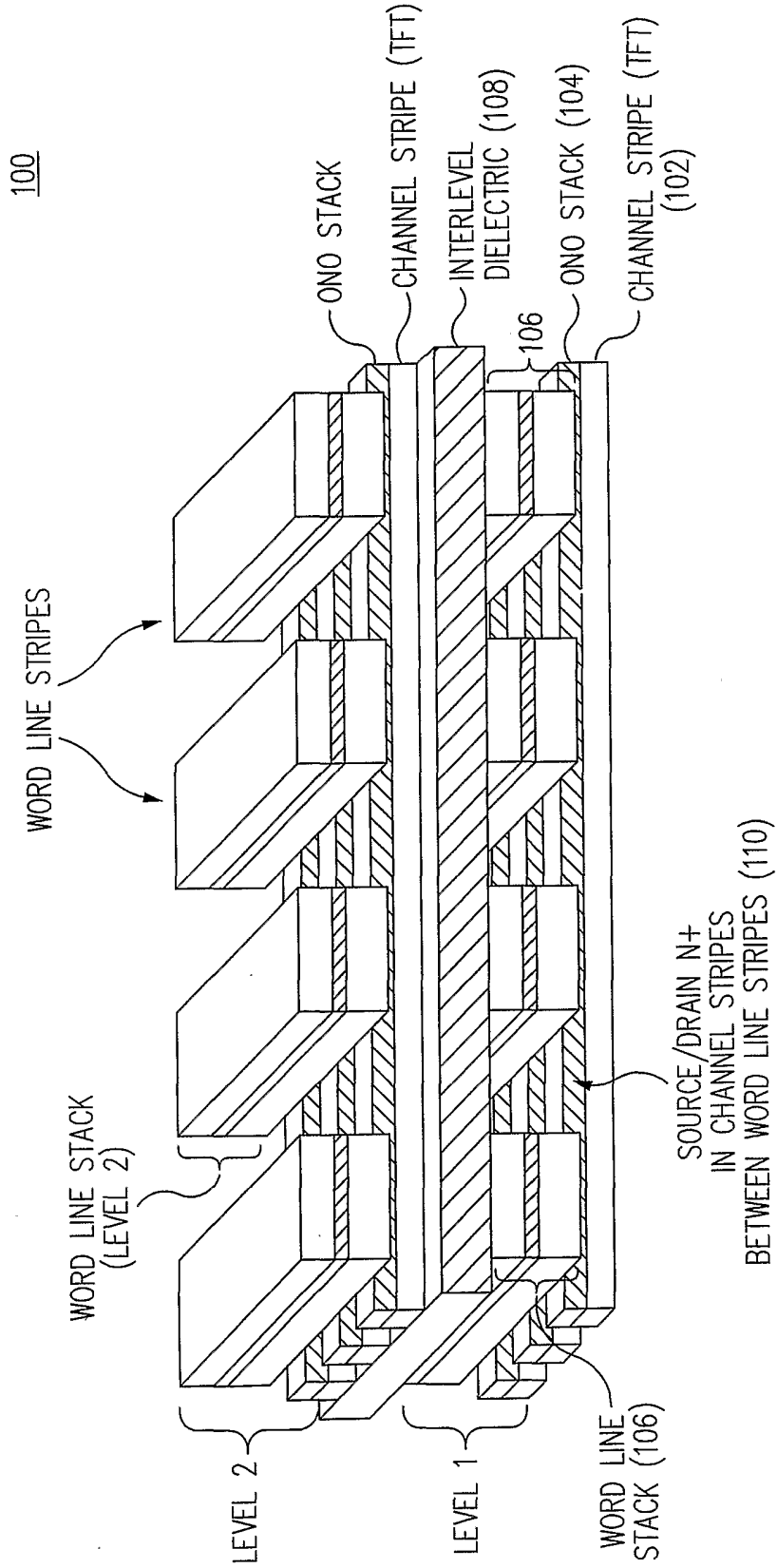

FIG. 1

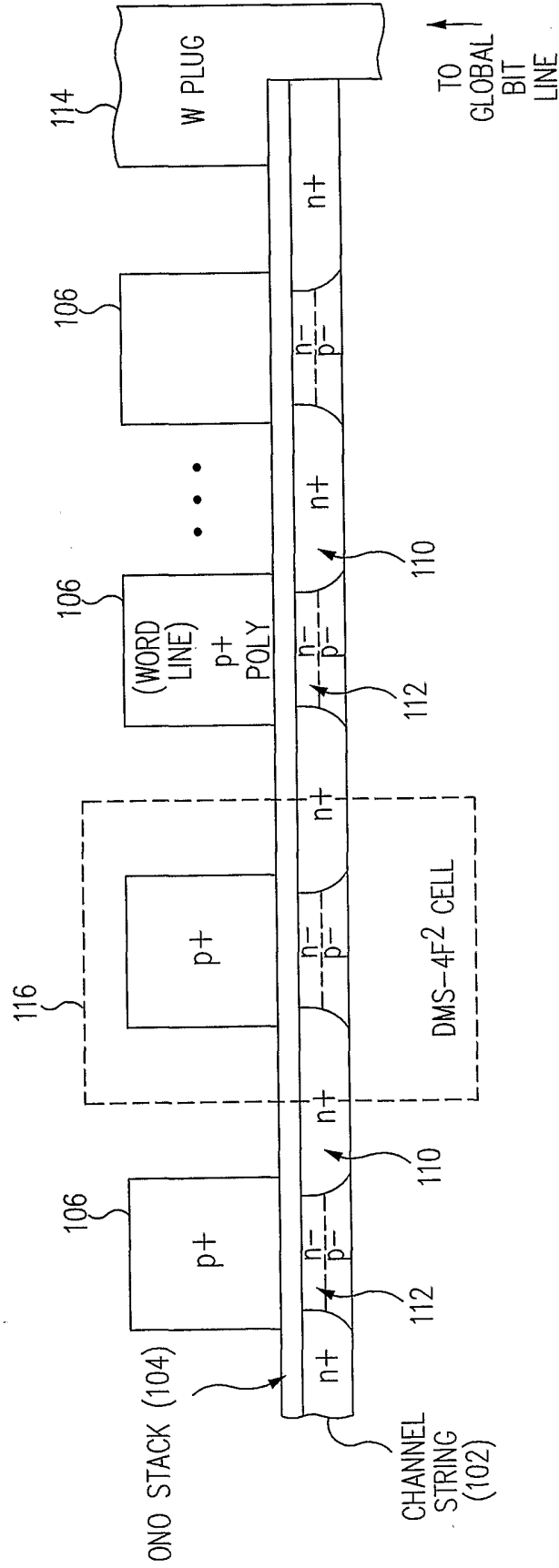

FIG. 2

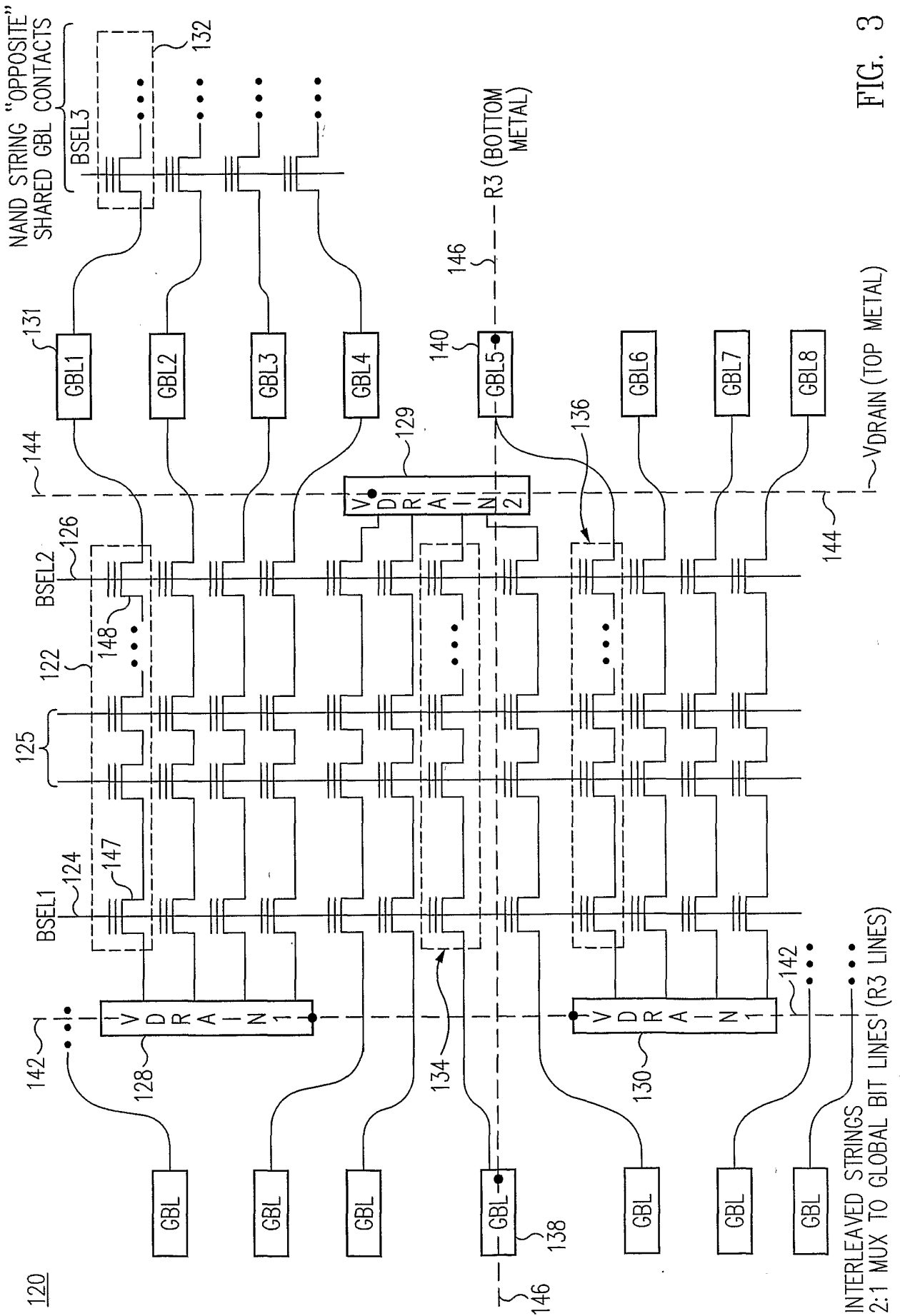

FIG. 3

4/22

BASIC ARRAY SCHEMATIC

160

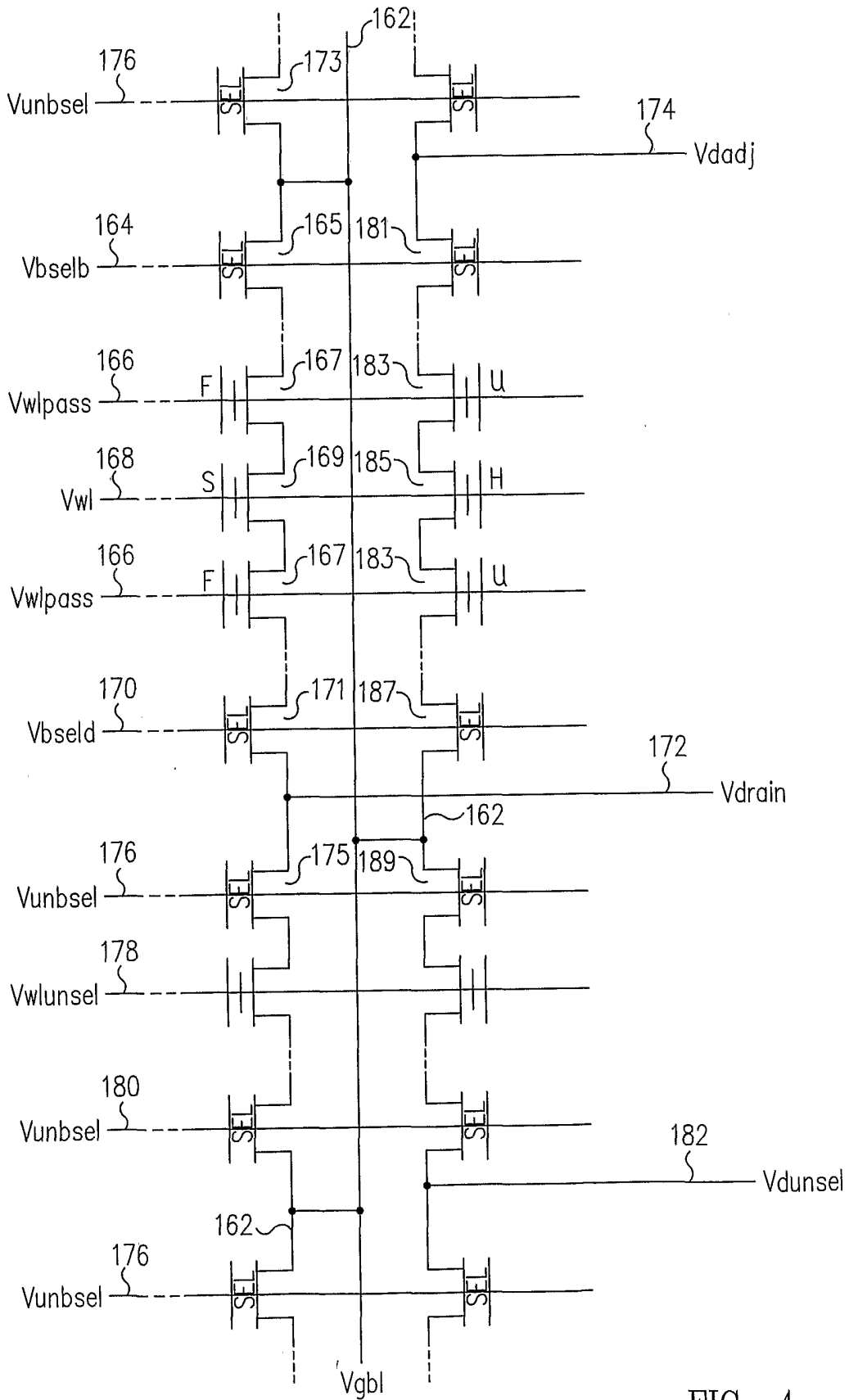

FIG. 4

5/22

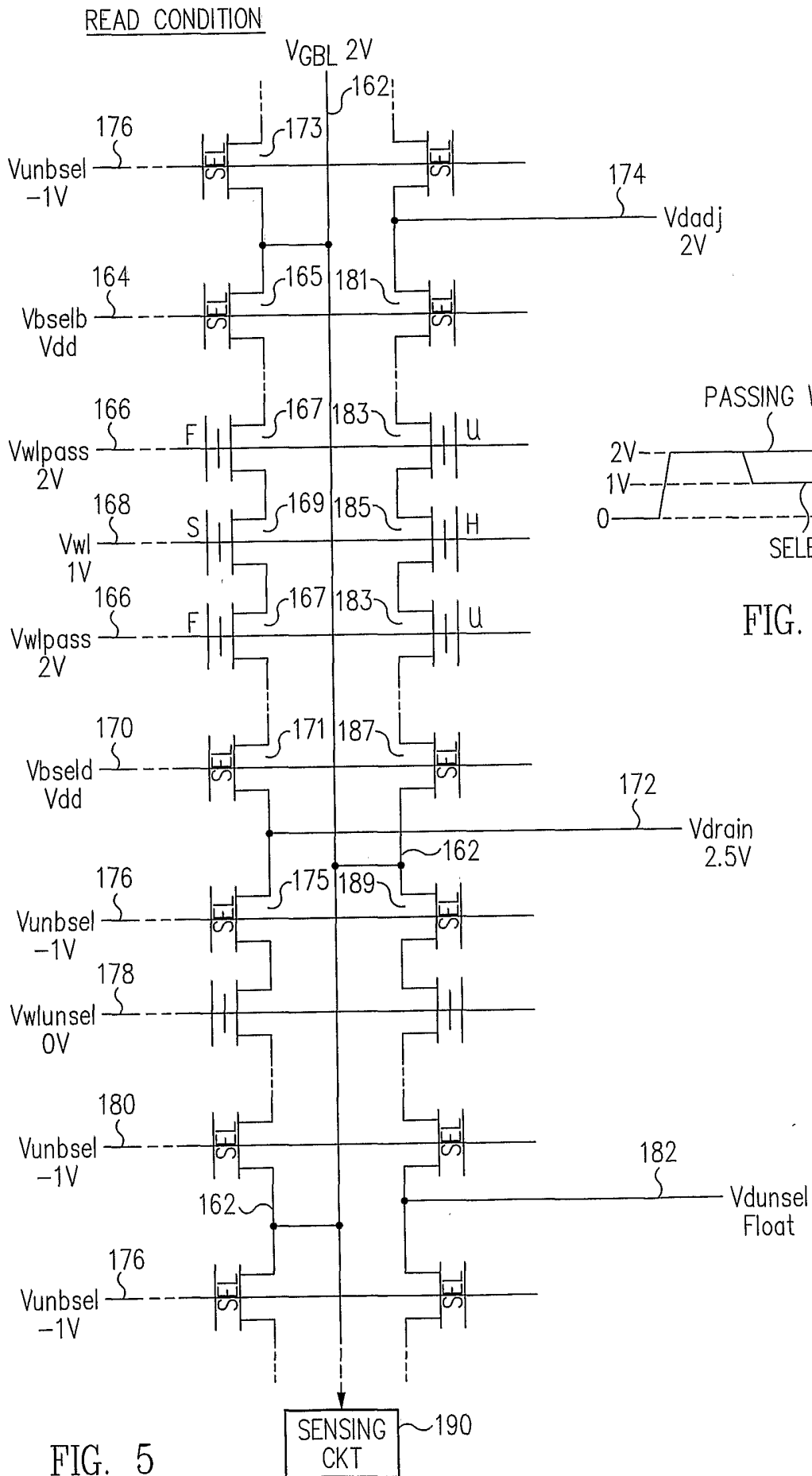
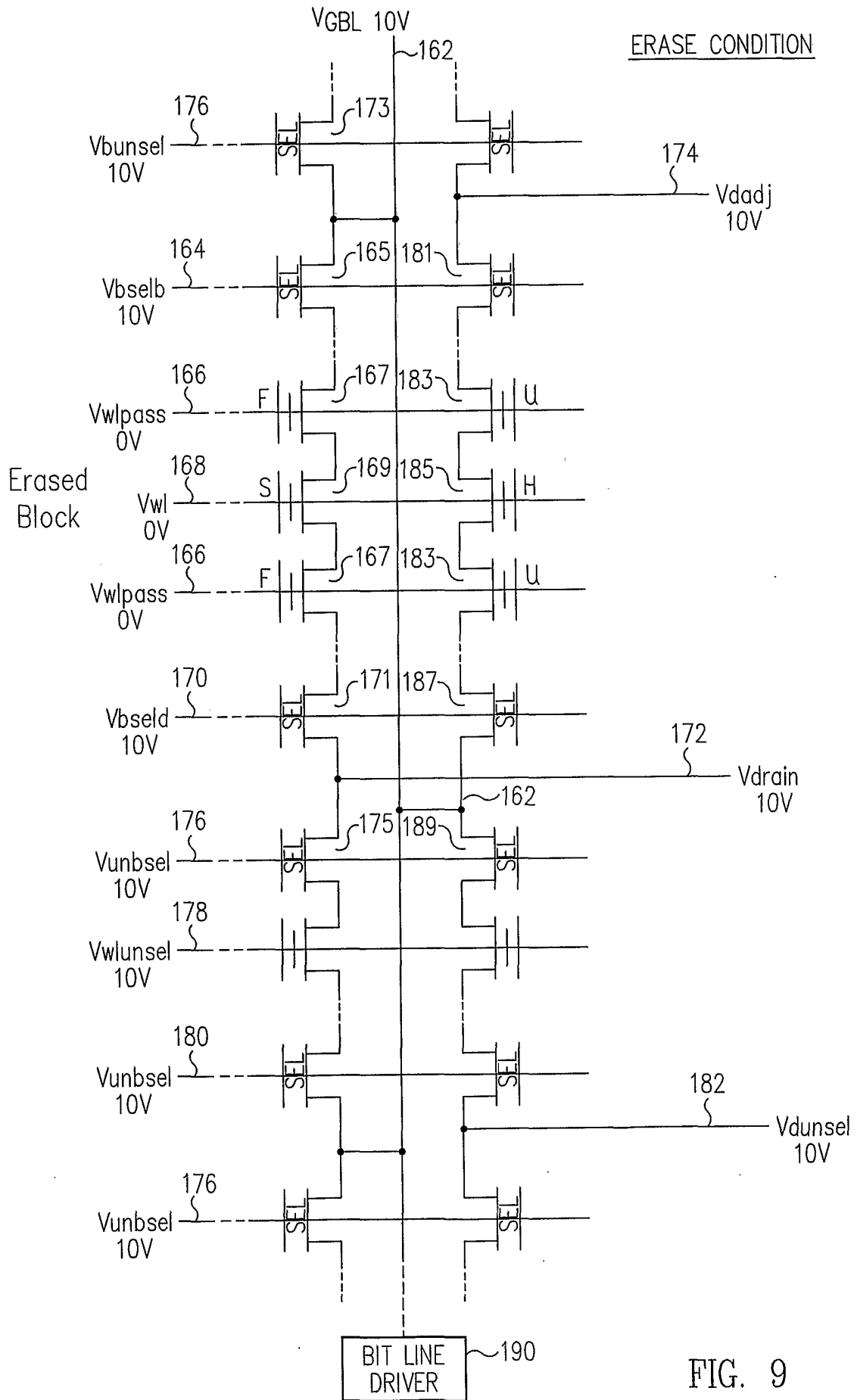

FIG. 5

FIG. 6

7/22



8/22

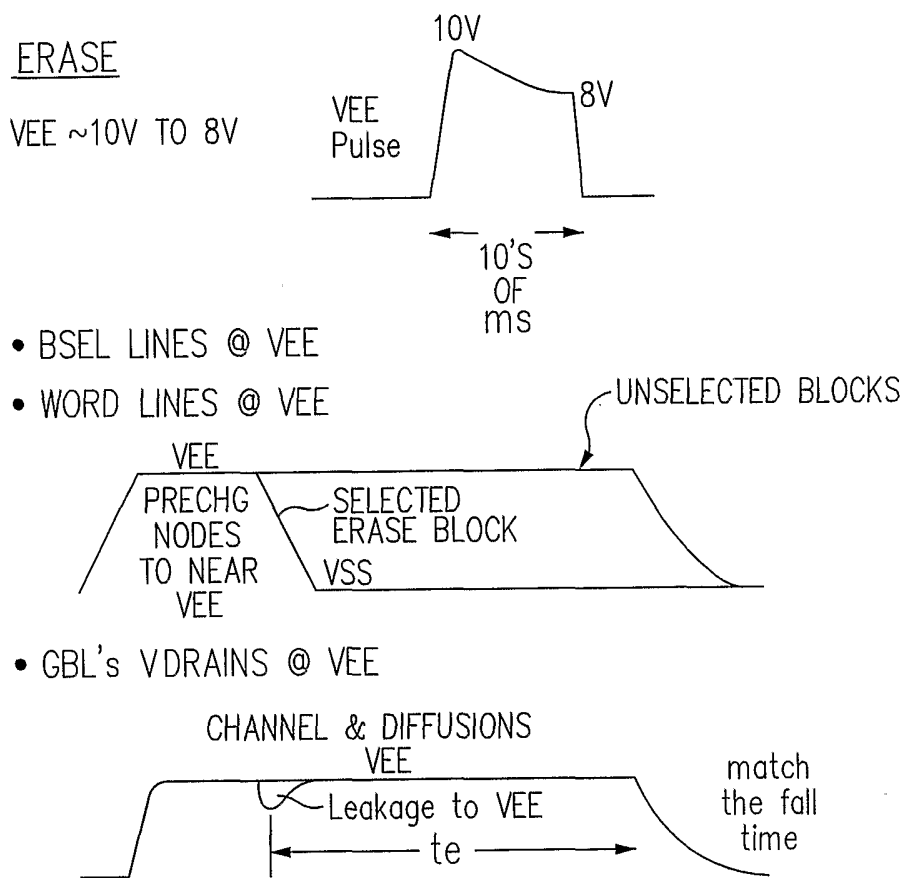

FIG. 10

10/22

260

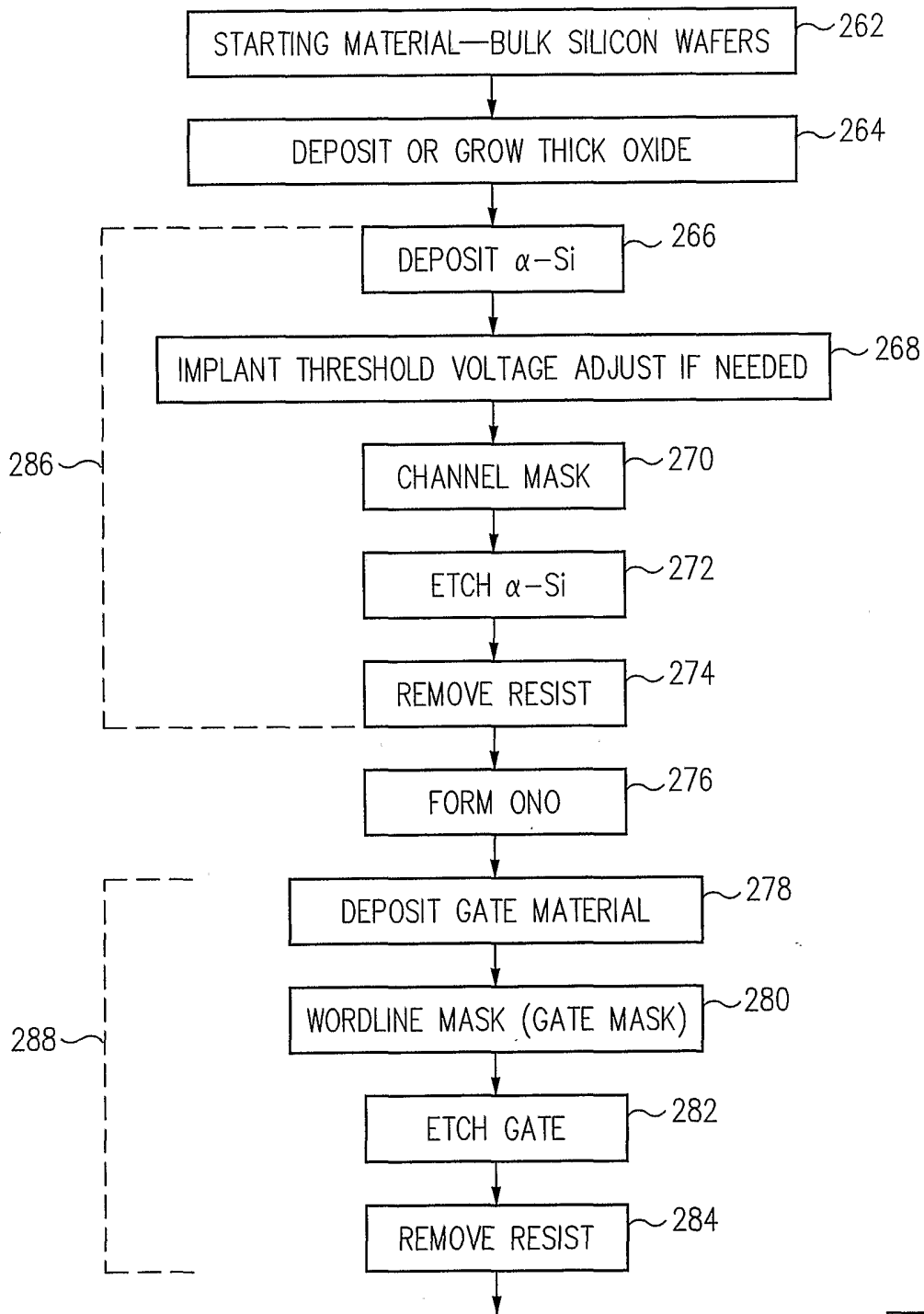

FIG. 12A

FIG. 12A
FIG. 12B

KEY TO FIG. 12

11/22

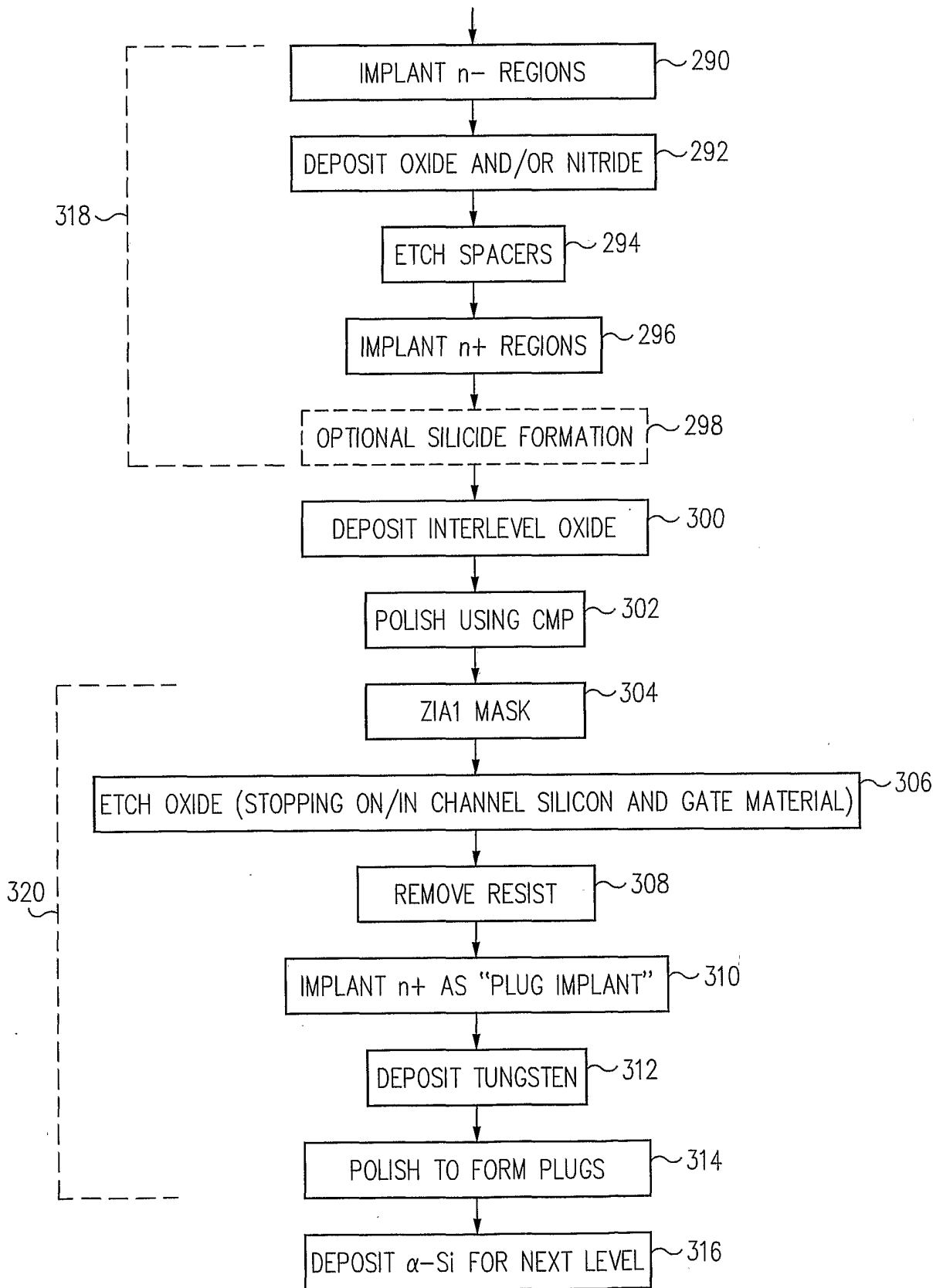

FIG. 12B

12/22

276

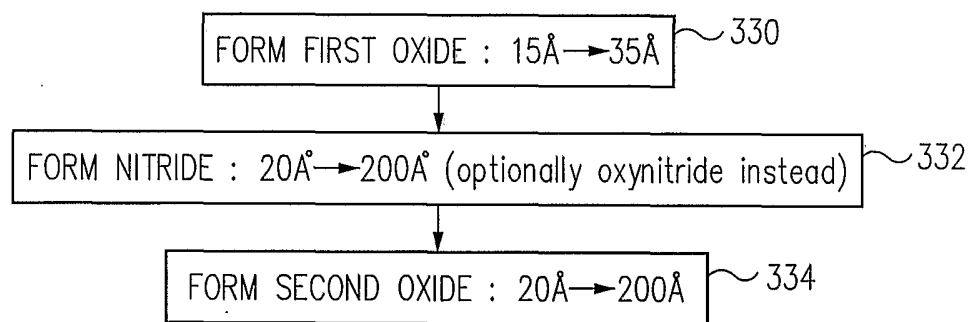

FIG. 13

278

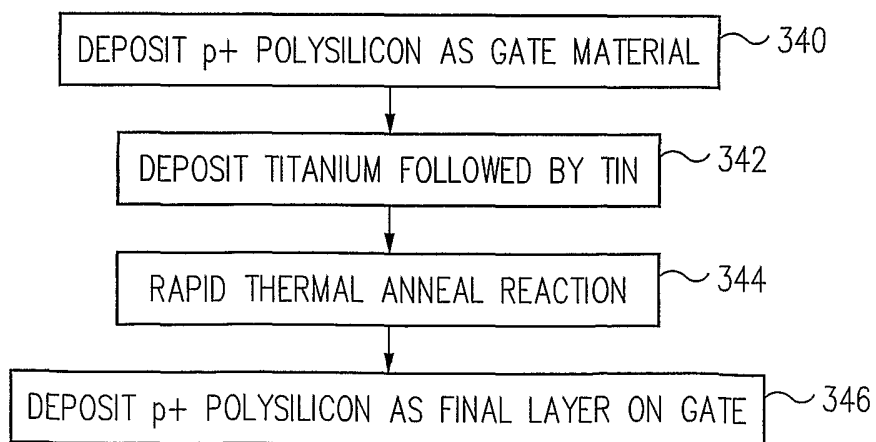

FIG. 14

278

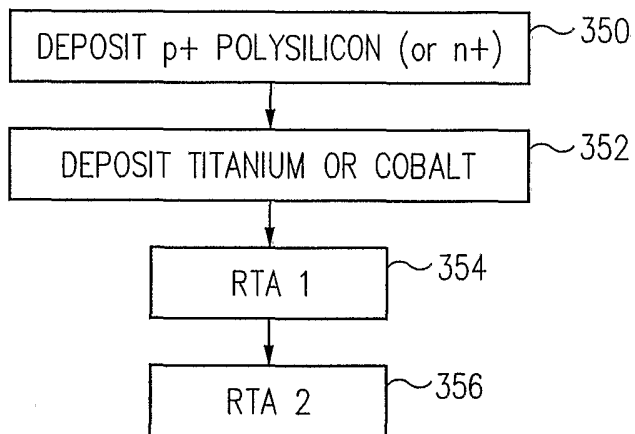

FIG. 15

298

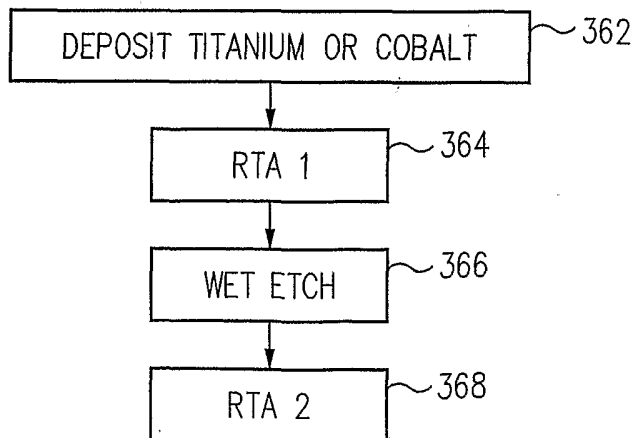

FIG. 16

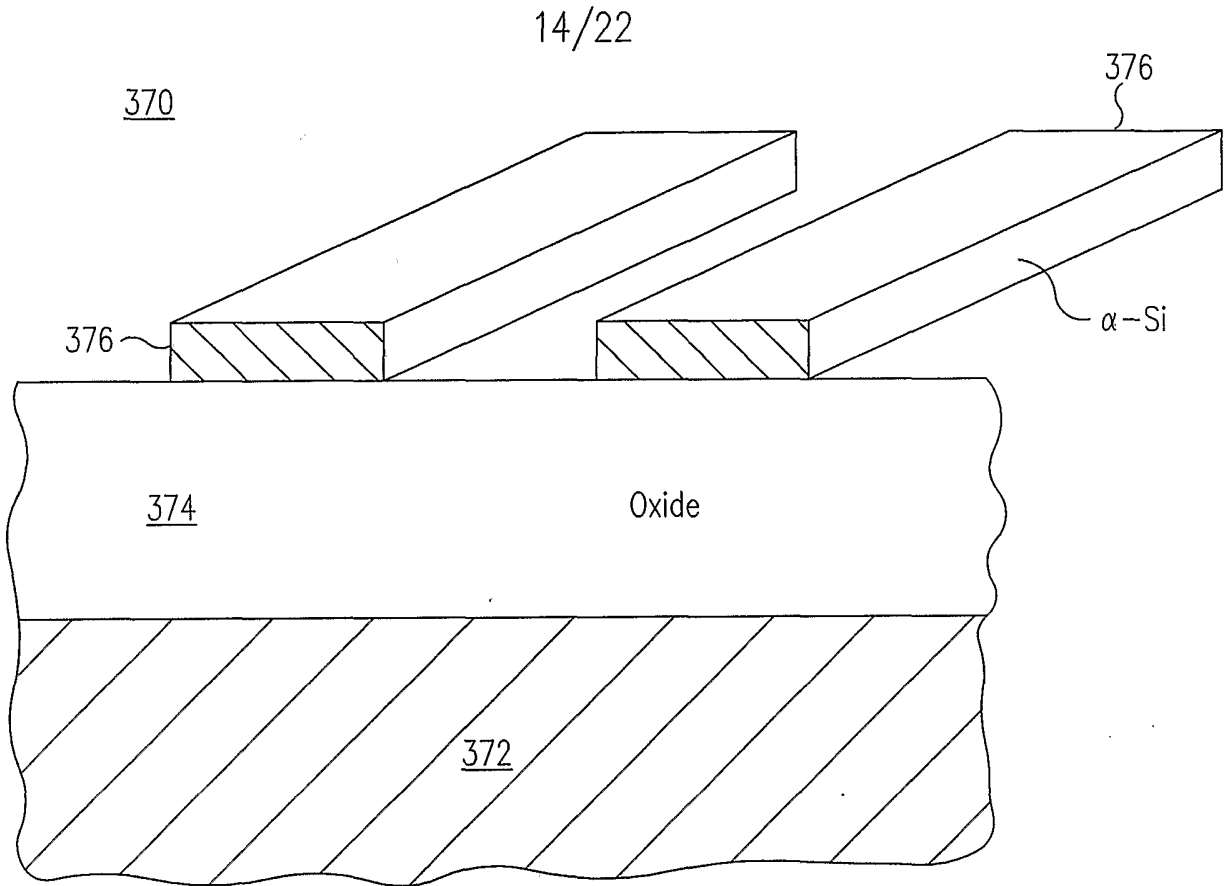

FIG. 17

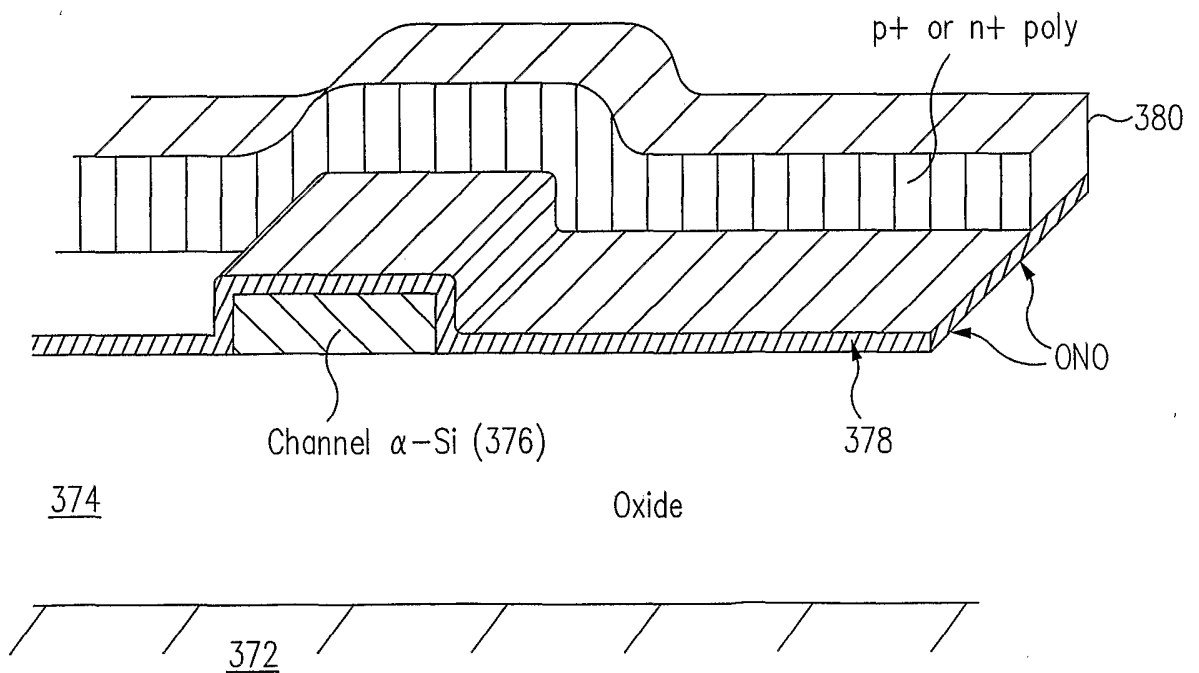

FIG. 18

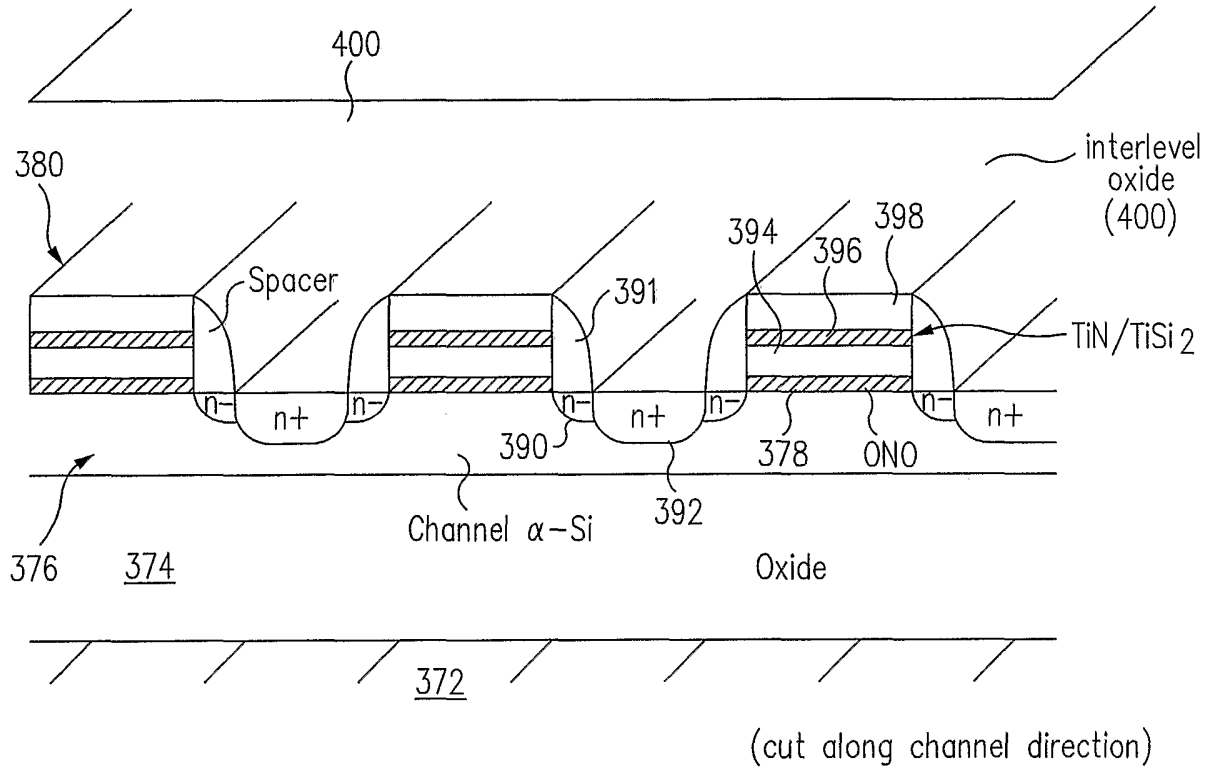

FIG. 19

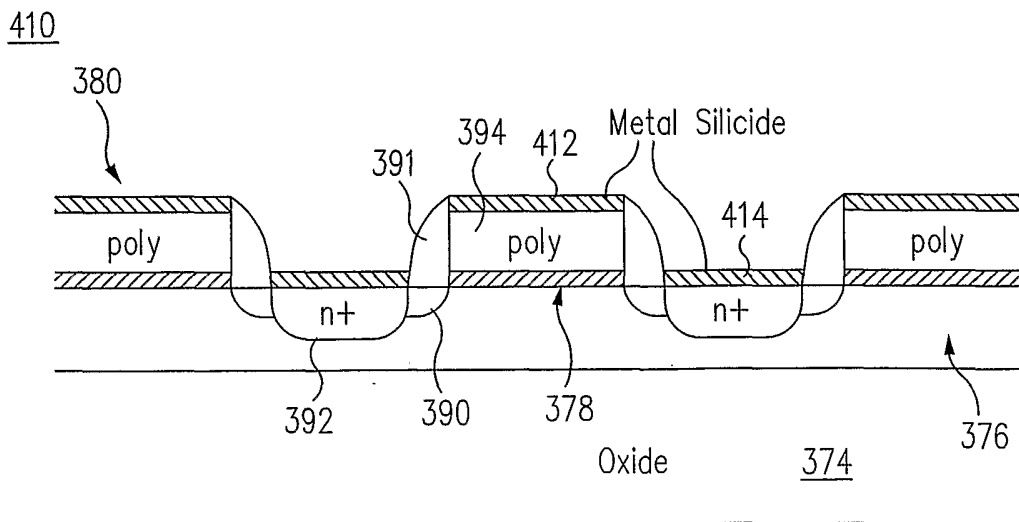

FIG. 20

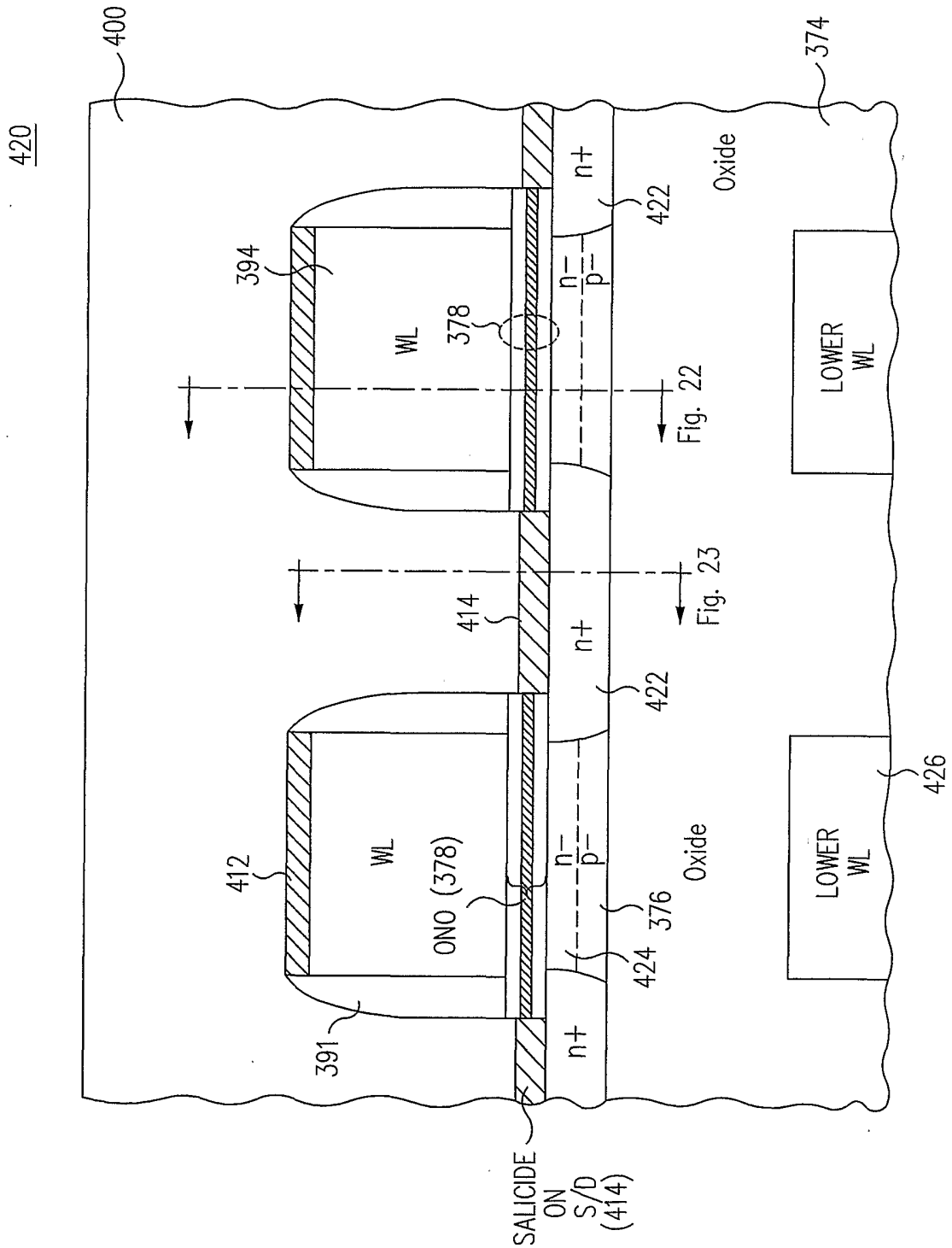

FIG. 21

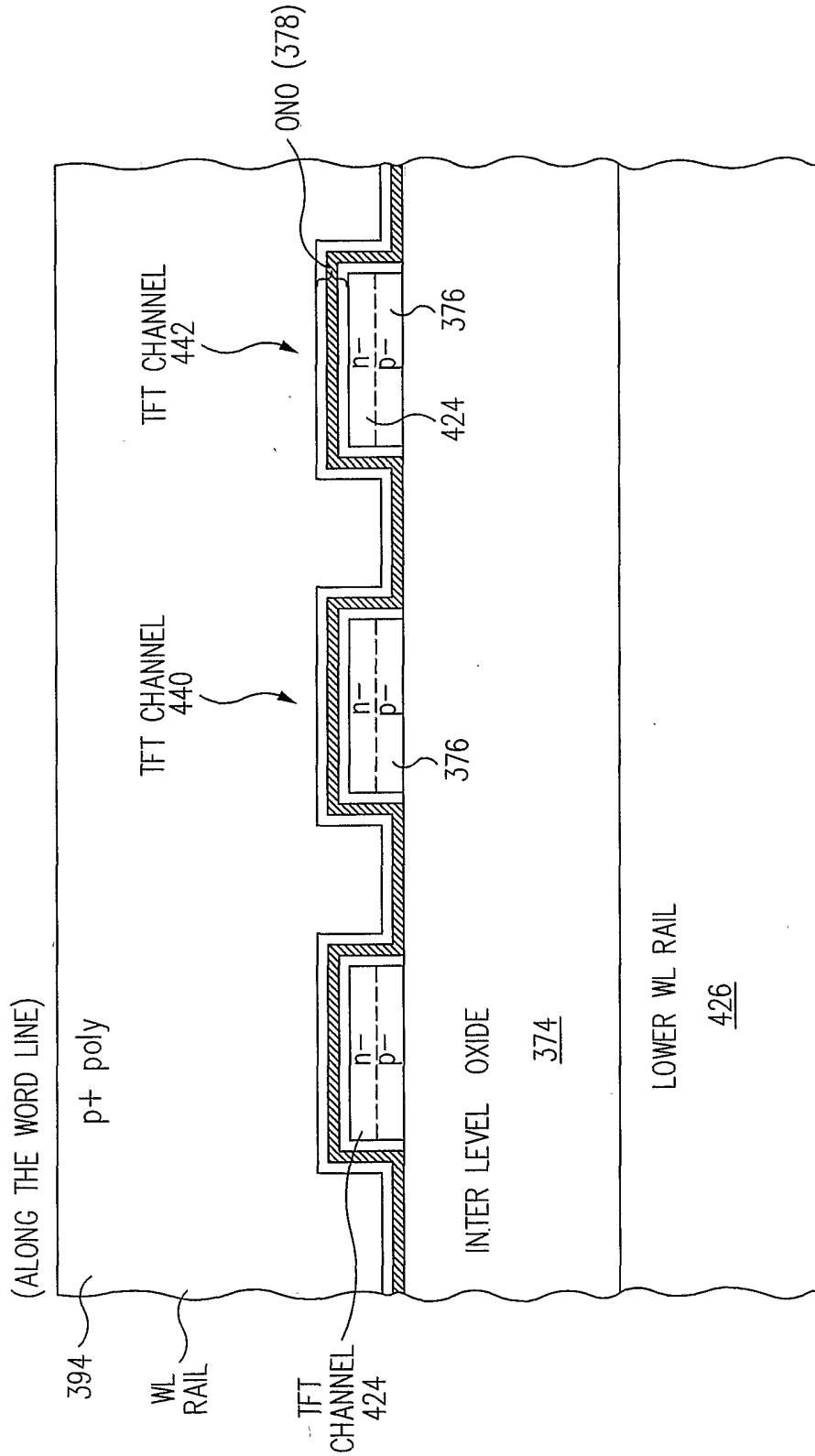

FIG. 22

CROSS-SECTION OF
SOURCE/DRAIN REGION BETWEEN
MEMORY CELLS ON STRING

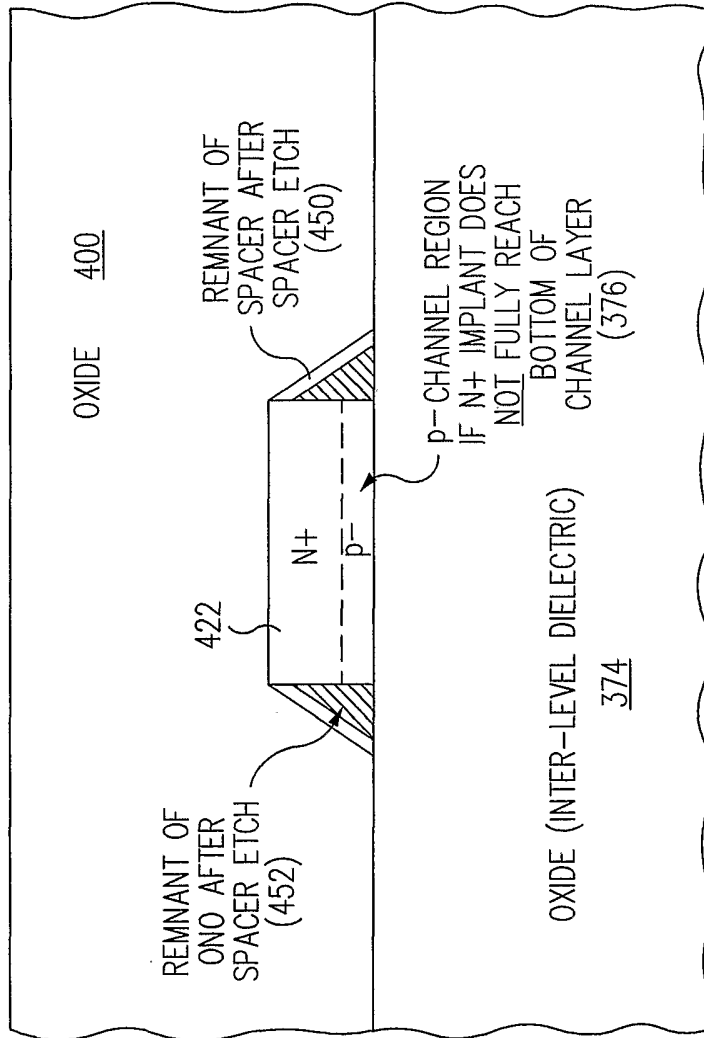

FIG. 23

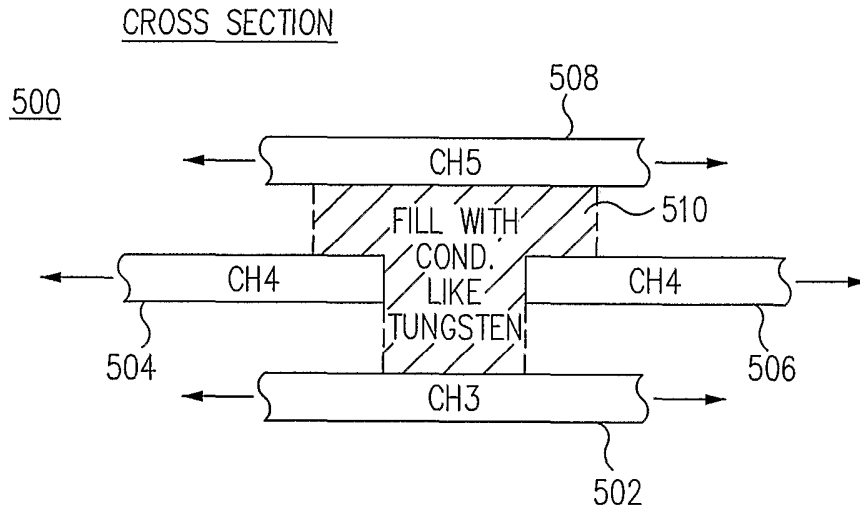
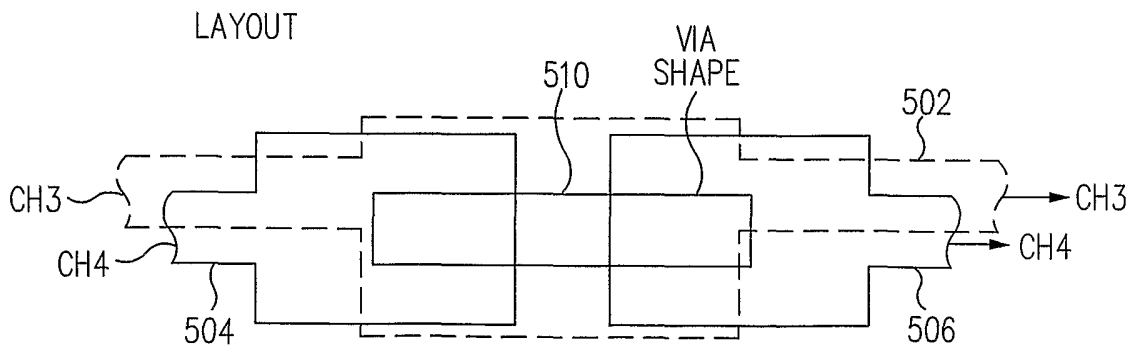

FIG. 24



CH5 NOT SHOWN. IT CAN BE SAME SHAPE AS CH3. ADDITIONAL LAYERS CAN STACK ON TOP. (EG - CH5/CH6/VIA/CH7 REPEATING THIS PATTERN.)

FIG. 25

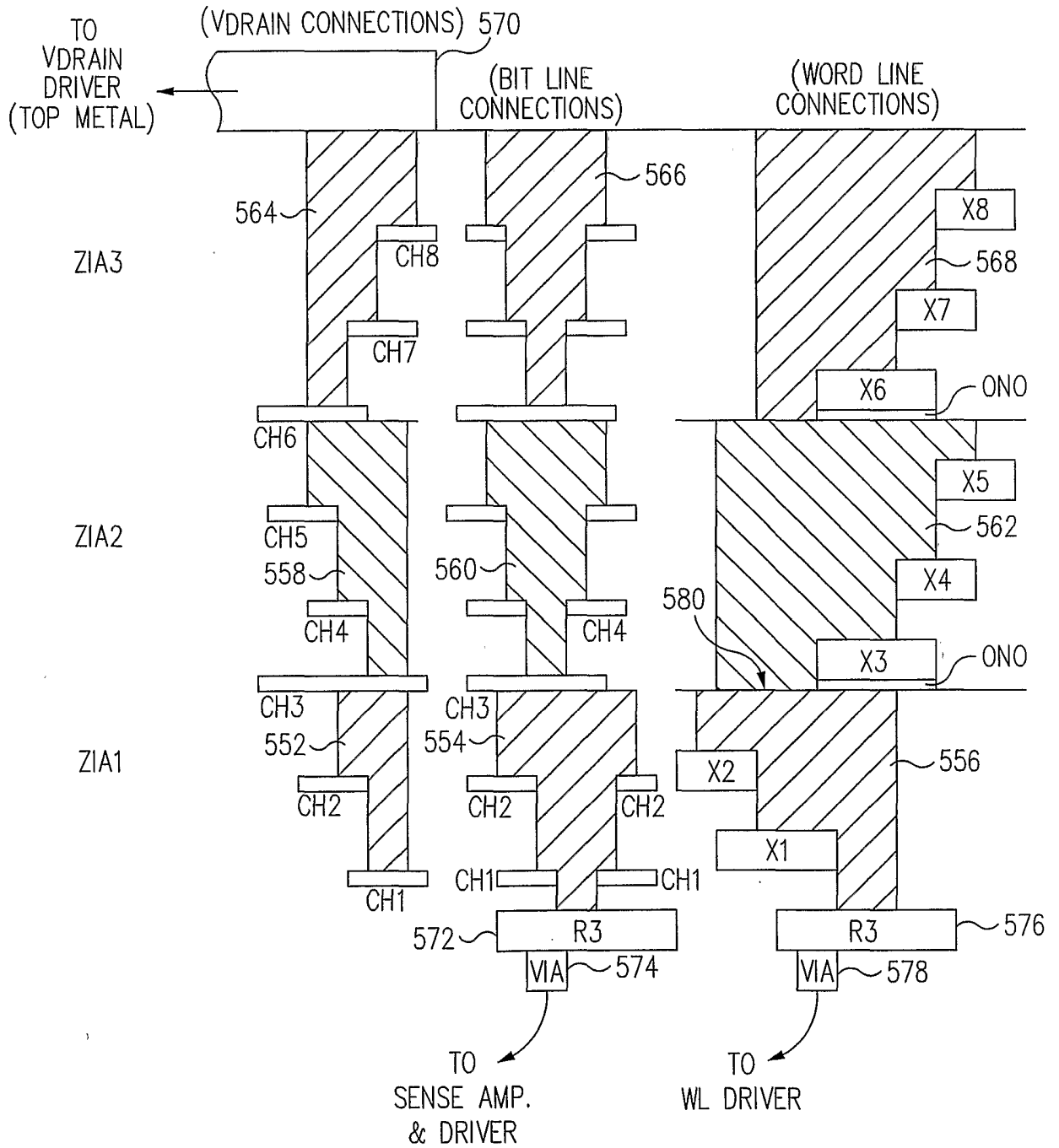

FIG. 27

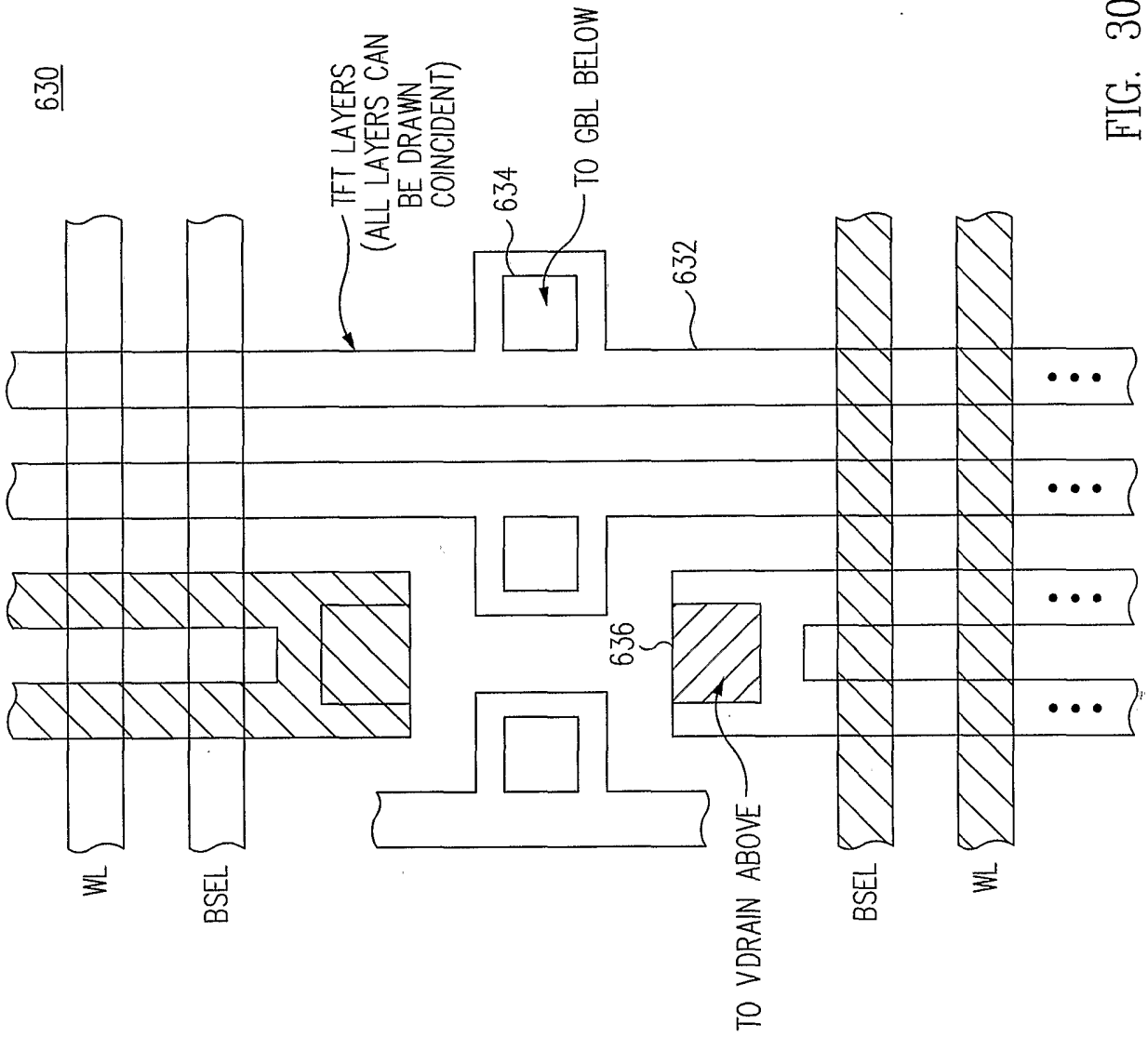

FIG. 30

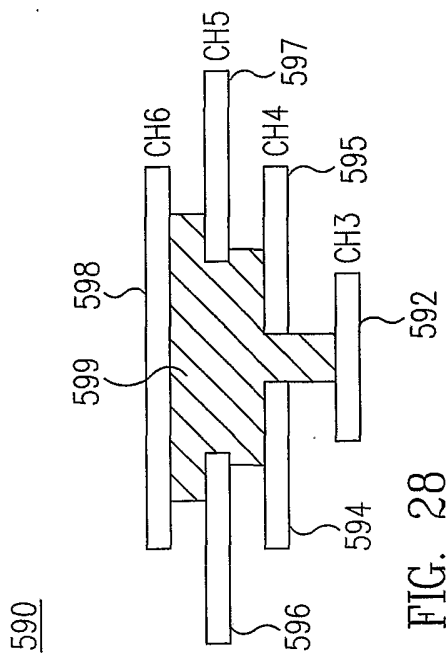

FIG. 28

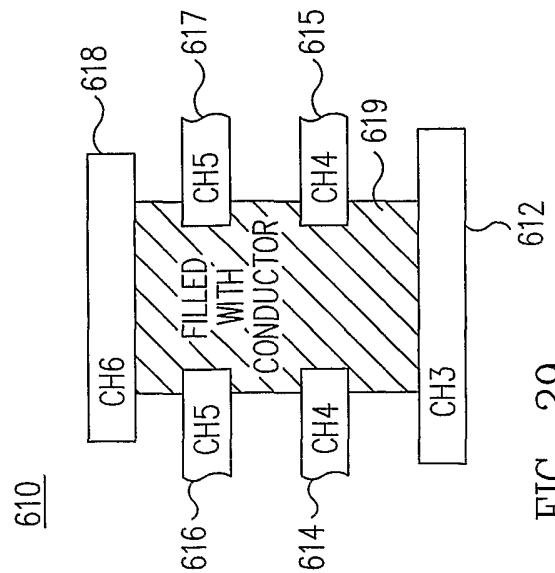

FIG. 29