

(19) World Intellectual Property
Organization
International Bureau



(43) International Publication Date
29 December 2004 (29.12.2004)

PCT

(10) International Publication Number
WO 2004/113886 A1

- (51) International Patent Classification⁷: G01N 21/55, 33/543, 35/00, B01L 3/00
- (21) International Application Number: PCT/IB2004/050895
- (22) International Filing Date: 14 June 2004 (14.06.2004)
- (25) Filing Language: English
- (26) Publication Language: English
- (30) Priority Data: 03101893.0 25 June 2003 (25.06.2003) EP
- (71) Applicant (for all designated States except US): KONINKLIJKE PHILIPS ELECTRONICS N.V. [NL/NL]; Groenewoudseweg 1, NL-5621 BA Eindhoven (NL).
- (72) Inventors; and
- (75) Inventors/Applicants (for US only): PRINS, Menno Willem Jose [NL/DE]; c/o Philips Intellectual Property &, Standards GmbH Weisshausstr. 2, 52066 Aachen (DE). SCHLEIPEN, Johannes Joseph Hubertina Barbara [NL/DE]; c/o Philips Intellectual Property &, Standards GmbH Weisshausstr. 2, 52066 Aachen (DE).
- (74) Agent: MEYER, Michael; Philips Intellectual Property &, Standards GmbH Weisshausstr. 2, 52066 Aachen (DE).
- (81) Designated States (unless otherwise indicated, for every kind of national protection available): AE, AG, AL, AM, AT, AU, AZ, BA, BB, BG, BR, BW, BY, BZ, CA, CH, CN, CO, CR, CU, CZ, DE, DK, DM, DZ, EC, EE, EG, ES, FI, GB, GD, GE, GH, GM, HR, HU, ID, IL, IN, IS, JP, KE, KG, KP, KR, KZ, LC, LK, LR, LS, LT, LU, LV, MA, MD, MG, MK, MN, MW, MX, MZ, NA, NI, NO, NZ, OM, PG, PH, PL, PT, RO, RU, SC, SD, SE, SG, SK, SL, SY, TJ, TM, TN, TR, TT, TZ, UA, UG, US, UZ, VC, VN, YU, ZA, ZM, ZW.
- (84) Designated States (unless otherwise indicated, for every kind of regional protection available): ARIPO (BW, GH, GM, KE, LS, MW, MZ, NA, SD, SL, SZ, TZ, UG, ZM, ZW), Eurasian (AM, AZ, BY, KG, KZ, MD, RU, TJ, TM), European (AT, BE, BG, CH, CY, CZ, DE, DK, EE, ES, FI, FR, GB, GR, HU, IE, IT, LU, MC, NL, PL, PT, RO, SE, SI, SK, TR), OAPI (BF, BJ, CF, CG, CI, CM, GA, GN, GQ, GW, ML, MR, NE, SN, TD, TG).
- Published:
— with international search report

[Continued on next page]

(54) Title: SUPPORT WITH A SURFACE STRUCTURE FOR SENSITIVE EVANESCENT-FIELD DETECTION

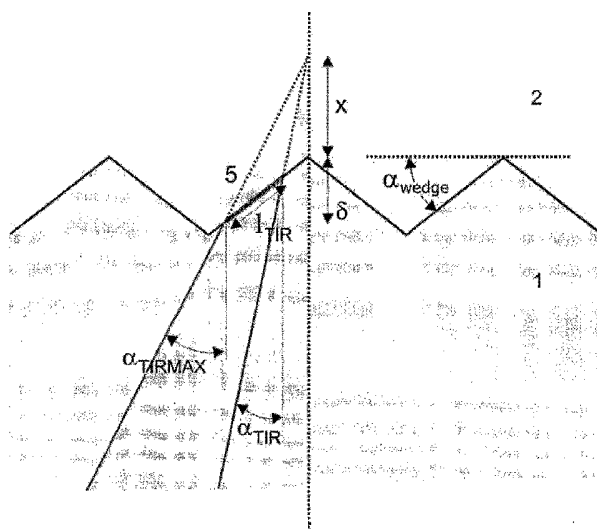

(57) Abstract: The present invention is concerned with a support (1), in particular an optical disc, with a surface structure for the detection of at least one optically-active substance within the evanescent-field (5) at one surface of the support (1), whereby the surface structure allows the generation of an evanescent-field (5) in a medium (2) adjacent to the surface structure. The surface structure comprises one or more sections of the surface of the support (1), which are inclined (α_{wedge}) with respect to the general orientation of the surface of the support (1). The invention also concerns a device employing such a support (1) with a surface structure, in particular an optical disc and uses of the support (1) with a surface structure and the device.

WO 2004/113886 A1



For two-letter codes and other abbreviations, refer to the "Guidance Notes on Codes and Abbreviations" appearing at the beginning of each regular issue of the PCT Gazette.

Support with a surface structure for sensitive evanescent-field detection

5

The present invention is concerned with a support, in particular an optical disc, with a surface structure for the detection of at least one optically-active substance within the evanescent-field at one surface of the support, whereby the surface structure allows the generation of an evanescent-field in a medium adjacent to the surface structure. The invention also concerns a device employing such a support with a surface structure, in particular an optical disc and uses of the support with a surface structure and the device.

Heterogeneous binding assays are routinely used in chemical and biological test systems to evaluate the capacity of a target compound or ligand contained within a test specimen, e.g. a fluid, to bind to immobilized capture probes. Such assays are used in all areas of chemistry, biochemistry or biology where the interaction between two or more chemical entities is examined. In particular in biology and biochemistry many processes, including, for example, regulative processes, signal transduction, the formation of larger functional complexes or the immune response depend on the specific interactions between proteins or between proteins and nucleic acids. A large variety of heterogeneous assay formats have been developed using many different approaches for detection of binding. For example, such assays are used for the diagnosis of diseases by immobilizing antibodies, which bind to a disease-related antigen on a surface and detecting the antigen contained in a sample solution. The presence or absence of the antigen is then indicative of the specific disease. Similar assays are also performed in approaches of directed evolution, wherein a variety of slightly different compounds immobilized at different positions on a surface are contacted with the same target and those compounds which show the strongest interaction with the target are selected for further analysis (e.g. by mass spectrometry) and further modification.

To detect binding of a ligand to a capture probe a variety of methods

have been used, which include electrochemical methods like, for example, potentiometric methods, and radiation-based methods including, for example, detection of fluorescence, light scattering or radioactivity. Some of these detection methods require the introduction of a label, which can be specifically detected. For example, such label can be attached to the capture probe and a variation of the signal upon binding of the ligand to the labeled capture probe is detected. It is also possible to label the ligand and detect the signal of the bound ligand upon binding to the capture probe. Another assay format involves labeling of a third component, which specifically binds the ligand and, thus, is recruited via the unlabeled ligand to the capture probe. The later assay format is called sandwich assay and is most commonly used, for example, in enzyme linked immunosorbent assays (ELISA). Other assay formats, which have equally been employed in the prior art include unbinding, displacement and competition assays. Depending on the way of measurement of the binding or unbinding a variety of labels have been used in the prior art including, for example, radioactive labels, fluorescent labels, scattering labels, or enzyme labels.

In a typical embodiment of a binding-type assay format the medium containing a labeled ligand is removed after incubation with the immobilized capture probes leaving behind labeled ligand only at those capture probes, to which the ligand has bound. In a next step, for example, when employing fluorescently labeled ligands the labels are now excited by light of a wavelength specific for the label and the fluorescence generated at each capture probe is measured. Usually in this arrangements the light used for excitation is directed onto the surface coated with the capture probes from above and the emitted fluorescence is detected.

Another approach for measuring fluorescence, which has been used in the prior art is the use of an evanescent-field for excitation of a fluorescent label. An evanescent-field is formed if a light beam is directed at an angle β at the interface of two materials, i.e. a translucent support material and a probe material, typically a liquid or a gas, and if the quotient of the refractive index of the two materials, i.e. the liquid sample or gas (n_{exit}), which lies adjacent to the translucent support material (n_{entrance}), through which the light beam is directed is smaller than the sinus of the angle β . This

situation leads to total internal reflection (TIR) of the light beam at the interface and the formation of an evanescent-field in the liquid or gas, wherein the depth of the field formed at the interface depends on the respective refraction indices, the angle, and the wavelength of the light. The use of an evanescent-field for the detection of fluorescence in an immune assay is disclosed in DE 196 28 002 wherein a light source is directed at an angle at a plane base-plate on top of which a capture probe is arranged to which a biological sample can be applied, however, the format disclosed in DE 196 28 002 in which a laser light source is directed at an angle at a plane surface covered by a second plane plate with a cut out section, which forms a cuvette-like compartment for holding the sample, is not suitable for high throughput applications, which require the read out of binding signals from many different locations on a surface. DE 196 28 002 does not disclose adaptations of the evanescent-field detection to high throughput applications, which would involve the excitation of different capture probes immobilized in different areas. The problem of the technology disclosed in DE 196 28 002 is in part the following: To address many different spots on the surface on the plane base plate the light beam of the laser, which has a fixed position, would have to be moved over the surface of the base plate in a scanning fashion, however, this would change the angle of the light beam with respect to the plate during the scanning and, thus, the depth of the evanescent-field at each scanned point. In addition the strength of the evanescent-field, i.e. the depth of the of the field formed, is small due to relatively small angles of inclination of the light source, which can be achieved in the set-up disclosed in DE 196 28 002.

This problem is solved by the provision of a support with a surface structures comprising inclined planes, which allow the generation of an evanescent-field at many different locations on the surface structure, while keeping the angle of the light beam used for generation of the evanescent-field essentially constant and at small or no inclinations with respect to the plane of the support, and moving either the support with a surface structure comprising the inclined plane(s) relative to the light source or moving the light source or the light beam relative to the support with a surface comprising the inclined plane(s).

Therefore, in one embodiment the present invention provides a support with a surface structure for the detection of at least one optically-active substance within

the evanescent-field, in particular for the detection of binding and/or unbinding events, at one surface of the support, in which in at least one area a plane of said surface is inclined with respect to the plane by an angle α_{wedge} from about 10° to about 85° . A support with the above delineated surface features will be capable of generating (an) evanescent-field(s) on the surface of the support once light is shone onto the surface even if the light is directed at the surface in a perpendicular fashion.

The term "support" as used in the present invention refers to a material having at least two surfaces which are essentially parallel to each other. The distance between the two surfaces is preferably between 0.1 mm and about 1 cm, and most preferably between about 0.5 mm and 3 mm. The material of the support is at least at the surface structure comprising the inclined plane(s) translucent. Preferably the support is made of essentially translucent material. Appropriate materials include without limitations polymers like, for example, poly carbonates, polyethylenterephthalat, cyclic olefinic polymers, and other materials such as glass and quartz. Supports within the meaning of the present invention, thus, include, for example, glass slides or plates and optical discs. Preferably the support is an optical disc. The support can be made entirely out of one material, can have a layered structure combining different materials or can have areas within the support made out of different materials.

The size and form of the support is not particular limited. It preferably is between 0.1 mm^2 and 400 cm^2 , more particular between 0.2 mm^2 and 200 cm^2 , most preferably between 1 mm^2 and 150 cm^2 . The support can have in a preferred embodiment a circular, rectangular, square or triangular shape. Most preferably the support has a circular shape.

The term "inclined plane" refers to a section of the surface of the support, which is inclined with respect to the general orientation of the surface of the support and which is essentially flat, flat or curved. In a preferred embodiment the surface of the plane is essentially flat or flat and in the most preferred embodiment the surface of the plane is flat.

In a preferred embodiment the angle at which the plane of the surface is inclined with respect to the surface of the support is from about 15° to about 75° , more preferably from about 25° to about 65° and most preferably from about 35° to about 55° . The appropriate angle, which leads to evanescent-field formation will in part be

determined by the inclination of the light beam with respect to the surface of the support, which is in a preferred embodiment determined by the numerical aperture of the focussing objective lens directing a light beam at the inclined plane in a reader device.

5 In the curved embodiment of the inclined plane the plane has different angles with respect to the surface of the support at each point along the curve, however, the angle of each point on the curve is preferably within the above indicated range and preferred subranges, thus allowing evanescent-field formation along the curved inclined plane.

10 The suitable angle α_{wedge} necessary to lead to total internal reflection (TIR) of the light directed at the surface, which in turn leads to the generation of an evanescent-field in the medium adjacent to the disc, i.e. on the surface of the support, depends on the refractive index of the translucent material of the optical disc (n_{support}), on the refractive index of the medium adjacent to the disc (n_{medium}), which preferably
15 contains a ligand, and on the angle α_{NA} between the light beam and the normal of the surface of the support. The inclination of the light beam (β_{TIR}) relative to the normal of the inclined plane is the sum of α_{wedge} and α_{NA} ($y_{\text{TIR}} = y_{\text{wedge}} + y_{\text{NA}}$). Total internal reflection and evanescent-field formation occurs when $y_{\text{TIR}} \geq \arcsin(n_{\text{medium}}/n_{\text{support}})$.

In most cases the medium containing the sample to be measured will be a
20 water-based solution or dispersion and, since water has a refractive index of about 1.33 the refractive index n_{medium} , i.e. the liquid comprising the sample, will be between 1.3 and 1.7, and preferably about 1.33. If a sample with a refractive index of 1.33 is used total internal reflection and evanescent-field formation will occur when the refractive index n_{support} of the material of the support is larger than 1.33 and if the angle β_{TIR}
25 fulfills above criterion for TIR. However, in some cases the liquid can be replaced by gas at the time of measurement and then the refractive index of n_{medium} will be about 1.0. Therefore, in order to allow TIR and evanescent field formation to occur at the support-gas interface the refractive index of the support material has to be larger than 1.0. Accordingly, in a preferred embodiment the refractive index n_{support} of the material of the
30 support is larger than 1.0 and smaller than 2.0 and preferably larger than 1.33 and smaller than 1.9 and most preferably between about 1.4 and about 1.8. In particular if the support of the present invention is its preferred embodiment, i.e. an optical disc,

then the refractive index n_{support} is preferably larger than about 1.33 and smaller than about 1.9 and more preferably between about 1.4 and about 1.8.

Taken together, the refractive index of the medium containing a sample adjacent to the support typically varies in the range of 1.0 to 1.7 and, therefore, a wide
5 variety of support materials can be selected in order to generate an evanescent-field on the medium side of the medium-support interface depending on the chosen β_{TR} . In the preferred embodiment of the support of the present invention, i.e. the optical disc, a support with the indicated optical properties can be made from a variety of materials including, for example, polycarbonates (PC) or cyclic olefinic polymers. However, it is
10 not required, that the entire support, preferably the entire disc is made out of material having the above indicated refractive and optical properties. It is possible to use this material only in those parts of the support, preferably the disc comprising a surface structure with one or more inclined planes.

Current methods of microstructuring of the surfaces of materials, in
15 particular optical discs, allow the formation of several billions of indentions (pits) to store data and a similar technology can be used to form within the surface of the optical disc further inclined planes capable of generating an evanescent-field in a medium once light is directed at them. Therefore, the support of the present invention comprises at least one area with such inclined plane(s) preferably between 10 areas and 1,000,000
20 areas. In medical diagnostic applications the support, preferably the disc will typically have between 1 and 100 different areas, however, for some applications like, for example, pathogen fine-typing or DNA polymorphism determination the number of areas will preferably be between 1.000 and 100.000. Preferably the areas comprising an inclined plane are separated from each other by a surface area which is either plane or
25 structured with channels, raised regions, trenches or structures to fluidically separate one or more areas of the support, preferably the disc, from one or more other areas of the support. The areas comprising one or more inclined planes can in a preferred embodiment be structured itself to form, for example, one or more channels, which extend radial from the center of the support, preferably the disc, or be structured to form
30 one or more channels arranged azimuthal around the center of the support, preferably the disc.

The surface size of an inclined plane depends on the depth of an inclined

plane, its inclination and its extension along the surface of the support. The term “depth” in this context means the distance between two theoretical planes, which run parallel to the surface of the support, and in which one plane touches the lower end of the inclined plane and the other touches the upper end of the inclined plane (see also “ δ ” in Figure 2). The depth of an inclined plane is preferably between about 0,1 μm and about 2 mm, more preferably between about 2 μm and about 100 μm , more preferably between about 4 μm and about 10 μm . The extension of the inclined plane along the surface is limited only by the size of the area comprising (the) inclined plane(s). This area can be structured, for example, like a radial, spiral or azimuthal channel and can comprise along the surface structures separating two or more inclined planes from each other or one inclined plane can extend along the complete area. The size of the inclined plane ranges in a preferred embodiment from about 100 nm^2 up to a size larger than the projected surface area of the support. This is due to its inclination and occurs, for example, if the inclined plane is arranged in a spiral covering the complete surface of the support. More preferably the inclined plane will have a surface area of between about 1 μm^2 and about 2 mm^2 and even more preferably between about 10 μm^2 and about 1 mm^2 .

The area on the support comprising the inclined plane and possibly additional inclined planes adjacent to the first inclined plane has in a preferred embodiment a surface area of about 100 nm^2 up to the entire surface area of the support. More preferably the area on the support comprising the inclined plane(s) will have a surface size of between about 100 μm^2 and about 40 mm^2 and even more preferably between about 1 mm^2 and about 20 mm^2 . The total surface size will depend on the dimensions of the support and in a preferred embodiment on the diameter of the disc. The size of the support is not particularly limited and can vary in a wide range. In a preferred embodiment the support will be structured as a disc and will have a diameter of between about 2 cm and about 30 cm and more preferably the diameter will be equivalent to the diameter of a CD/DVD.

In a preferred embodiment of the invention the surface of the support comprising one or more inclined planes is covered by a top plate. This serves to prevent efflux of medium, undesired mixing and/or evaporation of liquid from the surface of the support. The distance between the top plate and the surface is preferably between about

1 μm and about 2 mm and more preferably between about 30 μm and about 500 μm .
The top plate can connect with, for example the upper edge of the inclined planed,
raised regions or other surface structures in some or all areas of the surface of the
support to form separated reaction regions, channels or the like.

5 Other structures which are included in preferred embodiments of the
support comprise feed or purge lines, fluid inlet and outlet ports, valves, mixing
chambers, passive and active switches, sample pretreatment elements such as filters,
beads or columns comprising appropriate matrices like, for example, anionic or cationic
exchange resins, immuno-affinity resins or liquid storage compartments like, for
10 example, reagent storage compartments, wash fluid storage compartments or waste
storage compartments.

Fluid actuation within the support can be managed by a variety of means
known in the art including but not limited to over- or underpressure, centrifugal forces,
capillary forces, peristaltic forces, magnetic forces, electrical forces (e.g. electrophoresis
15 or dielectrophoresis).

Beside the above outlined structures other structures can also be present
on surface of the support or embedded in the support like, for example, pit-patterns as in
CD and DVD (re-)writable and/or ROM technology or masks and/or reflective coatings
which render part of the disc non-transmissive and which can be made, for example,
20 from metal like aluminum, silver or gold. These structures can serve, for example, as
information storage (read/write) and/or tracking device for the optical system when
reading the support, in particular if the support is structured in its preferred
embodiment, i.e. as an optical disc. The information can, for example, include
instructions for the reading device on how to perform the reactions and on the settings,
25 e.g. the wavelength, needed for reading the support. It is also envisioned that the results
and other process or sample data are stored on the support during or after the
measurement process. Tracking devices like, for example, pits are preferably arranged
in the vicinity of an inclined plane and are more preferably embedded in the support
material beneath the inclined plane to allow easy alignment of the light beam of a
30 reading device and localization of the individual inclined plane(s). This is particularly
useful if a light beam is used for reading the support, which has a focal point beneath
the inclined plane(s) on the surface of the support, preferably within the support (see,

for example, Fig. 3). Such tracking devices can be disposed, for example, on the internal interface of two layers of the support as is known from pits in single or multilayer CDs or DVDs.

In a preferred embodiment the support can be further structured in such
5 that the area on the surface of the support, which comprises the inclined plane(s), contains one or more additional planes adjacent to the first inclined plane(s) (see, for example Fig. 1). Preferably the second plane has a larger inclination, however, with an opposite sign, than the first inclined plane preferably in the range between 60° and 90° and is arranged in such that a "wedge" structured is formed. In a particularly preferred
10 embodiment the second plane is arranged adjacent to the first inclined plane in a symmetrical fashion leading to the formation of a pyramidal structure within the area (see, for example Fig. 5). The angle of inclination and the preferred angles of inclination of the two symmetrically inclined planes are as outlined above for the first inclined plane. In this arrangement evanescent-fields can be elicited on the surfaces of both planes
15 of the pyramidal structure thereby increasing the energy of the evanescent-field within one measuring area. Preferably in this embodiment two light beams having an identical angle (or angles in cases where the light in the light beam is not parallel but, for example, focused) with respect to the normal of the support, however, with an opposite sign are directed at the pyramidal structure. Each beam will undergo TIR at one of the
20 two symmetrical planes and will be refracted and transmitted into the medium at the other plane. In this arrangement transmission of light, which does not undergo TIR might occur and in some embodiments it might be necessary to inhibit light transmission into the medium adjacent to the support to improve measuring accuracy. This can be achieved, for example, by applying reflective or absorbing material to the
25 support, preferably to the surface of the support in appropriate areas. Such reflective materials comprise, for example, aluminum, gold or silver. The above described two inclined planes can also be separated from each other by one or more intermediate planes, which are preferably arranged parallel to the plane of the surface. Such intermediate planes can, for example, reflect light, which otherwise would be
30 transmitted into the medium. Fig. 3 shows, for example, an arrangement with three planes, in which the first and the second plane have a pyramidal structure with an intervening third reflective plane.

The inclination of the second plane can also be chosen in such that it totally reflects a beam which already has been reflected by TIR at the first inclined plane. This second TIR event will lead to the formation of a second evanescent-field within one measuring area and depending on the angles of inclination of the first and
5 second plane two evanescent-fields of varying or identical depths can be created within one measuring area. Preferably in this embodiment only one light beam, preferably with an angle with respect to the plane of the support, is directed at the surface of the support. It will undergo TIR at the first plane and will be refracted and transmitted into the medium at the second plane, however, the beam internally reflected at the first plane
10 will undergo a second TIR at the second plane. This arrangement will reduce the amount of light transmitted into the medium.

In a further embodiment the support of the present invention is also structured on the second surface, i.e. the surface opposite to the surface comprising one or more areas with inclined planes. The surface on the support directly opposite the
15 inclined planes can be either plane with respect to the plane of the support or inclined. The inclination can be identical or less than the inclination of the plane at which the optically-active substance is detected. Furthermore, the opposite surface of the support can also comprise structures needed for fluid distribution, sample preparation, sample application, fluid storage or sample removal as outlined above. Preferably those further
20 structures do not interfere with light directed at the inclined plane used for generation of an evanescent-field.

In a preferred embodiment the support of the present invention is provided with at least one capture probe which is attached to the inclined plane. The term "capture probe" comprises any chemical compound that is directly or indirectly
25 attachable to a surface. In a preferred embodiment the capture probe is selected from the group comprising proteins, in particular antibodies, receptors, enzymes, signaling proteins or fragments thereof, peptides, nucleic acids, in particular single stranded DNA, double stranded DNA and RNA, mono and polysaccharides, nucleic acid analogs, in particular PNA and small molecules.

30 The term "peptide" comprises polypeptides of a length between 2 and 50 amino acids, while the term "proteins" comprises polypeptides of a length of 50 and more amino acids. The amino acids of which the peptides or proteins are composed can

be naturally or non-naturally occurring amino acids and can be of D- or L-configuration.

The term "small molecules" comprises organic compounds of any structure smaller than 2000 g/mol. Such molecules are preferably used in drug development, since they are small enough to pass from the intestines into the blood of a patient and can, thus, be orally administered.

The capture probe can be attached directly or indirectly to the inclined plane(s) on the surface of the support while the attachment can be through covalent and/or non-covalent links. The support surface itself can be functionalized for this purpose with, for example, a hydrogel, a self-assembled monolayer, a surface allowing chemisorption or by physisorption. For covalent linking of capture probes to the surface of the support the surface of the inclined plane can be provided with groups capable of cross-linking with the capture probe like, e.g. epoxy-groups, which react with amino-groups in peptides or proteins. The skilled artisan knows a wide variety of chemical residues that allow the formation of covalent links between a (functionalized) support surface and capture probes. Similarly the capture probe(s) itself can be provided with reactive groups capable of forming a covalent or a non-covalent link with the surface of the support in particular in the region of the inclined plane(s). Attachment can also be indirect by, for example, coupling biotin to the capture probe and coating the surface of the support in particular the inclined plane(s) with protein A, which is capable of binding to biotin with high affinity. This mode of attachment leads to an indirect non-covalent attachment of the capture probe. A great variety of additional suitable attachment means are well known in the art. Preferably, after the linking process the capture probe forms a dense layer on the medium side of the inclined plane, which is then referred to as a "capture layer". The capture layer preferably covers the complete inclined plane, however, it can also be patterned to any shape on the inclined plane including spots, which are then referred to as "capture spots".

The chemicals necessary to attach the capture probe to the surface of the inclined planes as well as the capture probe(s) itself can be applied to the support surface by a variety of means including, for example, printing and spotting. Such directed application provides the additional possibility to lay down reagents and capture probes in a predetermined pattern on the surface of the support.

In general one type of a capture probe will be attached to one inclined

plane, however, in a further embodiment of the support of the present invention two or more different capture probes are attached next to each other on the same inclined plane. This embodiment is particular preferred, if inclined planes with large surface areas are arranged on the support, which than contain several different capture spots or
5 capture layers within one extended inclined plane. Depending on the type of assay, which is to be performed, in some embodiments a mixture of two or more capture probes is attached to one inclined plane.

In a further preferred embodiment the support of the present invention comprises reagents needed for sample preparation and/or measurement like, for
10 example, buffers, negative and positive controls, enzymes and/or enzyme substrates. These can be contained in the device as wet and/or dry material. In particular if dried material is provided then this will preferably be rehydrated prior to use by the addition of an appropriate liquid including, for example, water or buffer.

In a particular preferred embodiment of the support of the present
15 invention the support is an optical disc. An optical disc is an essential circular structure, which is preferably made out of polycarbonate. It preferably has a centered contact means, which allows contact with a reading device like, for example, a hole.

In a further aspect the present invention is also concerned with a kit comprising a support, preferably an optical disc, and at least one reagent. Reagents
20 within the meaning of the present invention comprise any chemical compound necessary to perform or facilitate a reaction on the disc. Preferably reagents are selected from negative controls, positive controls, buffers, enzymes, labeling agents and/or enzyme substrates.

A further aspect of the present invention is a device for the detection of at
25 least one optically-active substance within the evanescent-field at one surface of a support comprising: a) at least one light source, and b) at least one detector means wherein the at least one light source is arranged in such that it is opposite to the surface of a support where detection occurs once the support is placed in the device.

The detector means can be positioned on the same side or opposite to the
30 light source. In a preferred arrangement at least one detector means is arranged on the same side and more preferably the detector means is arranged to detect any radiation emitted back from a support placed in the device towards the light source. This is the

usual arrangement of a silicon PIN or CMOS-detector and a CD/DVD-player, where a splitter is placed in the light path of the laser diode, which directs the light reflected back towards a detector. The same arrangement can be used in the present invention, which allows the integration of light source and detector within a small unit which can
5 be easily moved in x or y direction with respect to the surface of the support, preferably the optical disc. However, the detector can also be placed on the opposite side of the light source, i.e. on the side of the medium, which leads to a separation of the two light systems. In this case appropriate means must be provided to assure exact alignment of the light source and the detector means. This is necessary to allow the assignment of the
10 measurement of radiation elicited by the evanescent-field to a particular inclined plane.

The light source preferably generates essentially monochromatic light. Thus, the light source is preferably a laser and more preferably a laser diode. The light source can be further provided with appropriate filters to eliminate, for example, light of undesired frequencies or to polarize the light. Preferably the laser is tunable to different
15 wavelengths in case when evanescent-fields of different depths are required and/or in cases when different frequencies of excitation are needed for the detection of the optically-active substances, in particular for the detection of binding and/or unbinding events. Alternatively or additionally further light sources generating light of a different wavelength can be included in the device of the present invention. These light sources
20 are in a preferred embodiment arranged in such that light of all light sources is directed at the same point on the surface of the optical disc. This allows the simultaneous measurement of, for example, the competition of two differently labeled ligands for binding to (a) capture probe(s).

In a preferred embodiment the angle $|\alpha_{NA}|$ of the light (α_{NA} is the angle
25 between the normal of a support inserted into the device and the light) is larger than 0° . This can be achieved by inclining the light source relative to the support or by “inclining” the light by optical means like, for example, by an objective lens or by a mirror. In a preferred embodiment an objective lens is placed in the light path, which focuses the light beam. This leads to an inclination of the light with respect to the
30 surface of the support, which increases towards the perimeter of the lens (see, for example, Fig. 4 and Fig. 7). Depending on α_{wedge} and β_{TIR} TIR will occur for all light, which has an inclination $\alpha_{NA} \geq \beta_{TIR} - \alpha_{wedge}$. This critical angle at which TIR will start to

occur, i.e. $\alpha_{NA} = \beta_{TIR} - \alpha_{wedge}$, is also called α_{TIR} . All light refracted in the objective lens to be directed at the support at an angle of at least α_{TIR} will, thus, be reflected by TIR and an evanescent-field will be formed. However, all light directed at the support at an angle of less than α_{TIR} will be refracted when passing through the support-medium interface.

In a preferred embodiment all light having an angle of less than α_{TIR} is blocked from being directed at the support by a mask which is placed in the light path (see, for example, Fig. 4-6). In some embodiments this mask will essentially completely block light from one side of the objective (see, for example, Fig. 4) or will be arranged to essentially block all light with an angle of α_{TIR} less than (see, for example, Fig. 5). The mask can be made of completely non-transmissive material or of a dichroic or polarization sensitive material (see, for example, Fig 10). The latter having the advantage that while all light directed at the support will elicit TIR, i.e. no light is directed at the support with an angle smaller than α_{TIR} , the radiation, e.g. the fluorescence, elicited by the evanescent-field is not blocked by a solid mask and more light can reach the detector leading to a more sensitive measuring set-up.

In another preferred embodiment one or more additional lenses are arranged in concentric circles around a central part lens. This composite lens is positioned between the light source and the support. The additional lens(es) are made out of material with a higher refractive index than the central part lens (see, for example, Fig. 6). While the center lens is used to direct light at the support at an angle $\geq \alpha_{TIR}$ the second or further lens, having a higher refractive index than the center lens, provides a wider acceptance angle for collecting the radiation emitted by the ligand and, thus, this set-up has a higher sensitivity than the single lens set-up. This embodiment preferably includes a mask as outlined above to block essentially all light with an angle less than α_{TIR} .

In addition to the features of the optical system outlined above a variety of additional optical elements like, for example, collimators, splitters, dichroic splitters or the like can be included in the optical system of the device of the present invention. The device of the present invention can comprise features which are well known in the art from CD/DVD players or writers, in particular it can comprise parts or all of the optical set up including objective lenses, light sources, detectors, filters, splitters or the

drive and actuation devices employed in such players or writers.

The detector means can be any means capable of detecting radiation, preferably a PIN diode or CMOS-device. The choice of the suitable detector means depends on the radiation which needs to be detected, which in turn depends on the optically active substances, in particular on the label comprised in the optically active substance. Consequently, if the detection of the optically active substance, in particular the detection of binding or unbinding events depends on the detection of fluorescence, which has been stimulated by the evanescent-field, than the detector should be capable of detecting fluorescence of the relevant wavelength. If the signal is light scattered by the label or reflected (as in surface-plasmon-based detection), then the detector means should be capable of detecting light of the same wavelength as emitted by the light source. In a preferred embodiment of the device of the present invention one or more filters are arranged in front of the detector, which, for example, in case of the detection of fluorescent light can be a filter with a broad absorption spectrum and/or a polarizing filter. These filters serve to exclude scattered light of the light source, which could decrease the sensitivity of the assay.

In a further preferred embodiment of the device of the present invention the wavelength of the light source, the inclination of the light with respect to the normal of the disc α_{NA} and the angle α_{wedge} of the inclined plane(s) of the surface of the support is (are) selected in such that the depth (d) of an evanescent-field, which is formed in the medium containing the sample, is between 10 nm and 1 μ m, preferably between about 20 nm and 200 nm. The depth of an evanescent-field, which is caused by light of a given wavelength, can be calculated according to the following equation:

$$d = \frac{\lambda}{2\pi} * \frac{1}{\sqrt{n_{support}^2 * \sin^2(\alpha) - n_{medium}^2}}$$

whereby “ λ ” is the wavelength of the light, “ $n_{support}$ ” is the refractive index of the material of the support in the light path and “ n_{medium} ” is the refractive index of the medium comprising the optically active substance, in particular a ligand, which is to be measured, for example, for its binding or unbinding to the surface of the support, “ α ” is the angle of the light with respect to the normal of the interface between the two materials, i.e. the inclination of the plane, and “d” is the depth of the evanescent-field in the medium. Using the above indicated formula the skilled person can easily select the

depth of the evanescent-field based on the wavelength of the light emitted by the light source, the angle of inclination of the light with respect to the normal of the support and/or the angle of inclination of the inclined plane. The smaller the depth of the evanescent-field the less optically active substances are detected, which are not bound to the inclined plane but rather are contained within the medium. The selection of very small depths d in which the evanescent-field is formed leads to excitation of optically active substances only, if they are very close to the interface. If the depth of the evanescent-field is selected to only extend over the length of the capture probe and the molecule bound to the capture probe such selection would allow the detection of binding events on the surface of the support without removal of the medium containing unbound optically active substances and/or label since primarily optically active substances, which are bound to the surface of the support, e.g. to the attached capture probe, will be effected by the evanescent-field, e.g. excited to fluoresce.

However, in some embodiments of the support of the present invention and its use it is desired to generate an evanescent-field, which has a depth that also extends to molecules which are near the surface but not directly attached to the surface. This allows the measurement of the concentration of unbound optically active substance(s) and/or unbound labels in the medium. The concentration of the optically active substance(s) and/or labels in the medium, which binding or unbinding is to be measured, affects the amount and dynamics of the binding of the optically active substances and, thus, is important to know. This is particularly the case when quantitative measurements and not only qualitative measurements are to be carried out.

In the embodiment of the present invention in which the light is focused in the device on the support (see, for example, Fig. 2) and, thus, the light beam reaches the inclined plane under a variety of angles, the length of the section of the inclined plane at which TIR occurs, i.e. the TIR active area length (l_{TIR}), can be determined by the following formula:

$$l_{TIR} = \frac{\sin(\alpha_{wedge}) \cdot \sin(\alpha_{TIRMAX} - \alpha_{TIR})}{\sin(\alpha_{wedge} - \alpha_{TIRMAX}) \cdot \sin(\alpha_{wedge} - \alpha_{TIR})} \cdot |x|$$

in which " α_{TIRMAX} " and " α_{TIR} " are the bounding angles for which TIR occurs at the interface of the inclined plane(s) formed on the surface of the substrate and the medium. The steepness of the inclined plane is defined by " α_{wedge} ", " x " is the distance of the

focal point from the upper edge of the inclined plane, also termed the “defocus” introduced in the system. In this embodiment “defocus” is needed in order to obtain reflection (TIR for angles of the light $\geq \alpha_{TIR}$) and refraction (for angles of the light $< \alpha_{TIR}$) at the surface of the inclined plane. If no defocus would be introduced ($x=0$), the support would be sampled in the near field of the focus where the incoming wave front is perpendicular to the surface of the support. In this case the angles α_{TIRMAX} and α_{TIR} would be virtually zero and no TIR would occur.

Preferably x is a few focal depths of the focussing system:

$$x \approx \sigma(1) \cdot \frac{\lambda}{NA^2}, \text{ and preferably between 1 and } 100 \text{ } \mu\text{m, more preferably between 2 and}$$

50 μm and most preferably between 4 and 20 μm . x can have a negative or positive sign, i.e. the focal point can be located beneath or above the surface of the support.

The depth of the inclined plane “ δ ”, which is required to accommodate the possible TIR active area length for a given defocus x can be determined as follows:

$$\delta = \left\{ \frac{\sin(\alpha_{\text{wedge}}) \cdot \sin(\alpha_{TIRMAX})}{\sin(\alpha_{\text{wedge}} - \alpha_{TIRMAX})} - 1 \right\} \cdot |x|$$

In a further aspect of the present invention the device of the present invention further comprises the support of the present invention. The device is adapted with suitable actuation devices like, for example, servo motors or piezo elements to move the support, for example, in x or y direction or in circular fashion. However, it is also possible to move the light source and/or the detector relative to the support, for example, in an x or y direction. In a particular preferred embodiment the support is an optical disc. The disc can be rotated in the device around an essentially centered contact means preferably a hole in the disc, which is used to center the disc in the device. In this embodiment the light source and/or the detector means can be stationary or move relative to the disc, preferably laterally.

A further embodiment of the present invention is the use of a support of the present invention or a device of the present invention for the detection of at least one optically-active substance within the evanescent-field at one surface of the support, in particular at a surface of an optical disc. A preferred use is the detection of binding or unbinding of an optically active substance contained within a medium to one or more inclined planes of the surface of the support by an evanescent-field. In a preferred

embodiment of the use of the present invention the optically active substance is detected by fluorescence, optical scattering and/or reflectance modulation.

The term "optical active substance" comprises any chemical entity capable of reflecting, refracting, adsorbing or scattering an evanescent-field or being
5 excitable to fluoresces or phosphores by an evanescent-field. The optical active substance either possesses this activity alone like for example, GFP-proteins or possesses it by virtue of one or more labels, which can be directly or indirectly attached. A wide variety of labels is known in the art like, for example, fluorochromes like, for example, FITC, Cy3, Cy5, rhodamine, fluorescein or quantum dots or auto-fluorescent proteins like, for
10 example, green fluorescent protein (GFP) or variants thereof or metal particles in particular gold or silver spheres (nanoparticles), or up-converting phosphors.

Label(s) can also be attached to the capture probe or additional components that may bind to the optical active substance and/or the capture probe.

In a preferred embodiment the optical active substance comprises a
15 ligand attached to a label.

The term "ligand" comprises any chemical entity capable of being bound by a capture probe as defined above. In particular the term ligand comprises nucleic acids and nucleic acids analogs, including DNA, RNA, PNA and the like; proteins and peptides, including enzymes, transcription factors, signaling molecules and signaling
20 molecule receptors, structural proteins and receptors; mono or poly saccharides; single cells, cell aggregates and tissue fragments, including all human, animal or plant cell types, preferably hemapoetic cells like, for example, T-cells, B-cells, macrophages, dendritic cells, platelets, red blood cells; bacteria including without limitation
Acidaminococcus, Acinetobacter, Aeromonas, Alcaligenes, Bacillus, Bakteroides,
25 *Bordetella, Branhamella, Brucella, Calymmatobacterium, Campylobacter, Cardiobacterium, Chromobacterium, Citrobacter, Clostridium, Corynebacterium, Edwardsiella, Enterobacter, Enterococcus, Erysipelothrix, Escherichia, Eubacterium, Flavobacterium, Francisella, Fusobacterium, Haemophilus, Helicobacter, Klebsiella, Lactobacillus, Legionella, Listeria, Micrococcus, Moraxella, Morganella, Neisseria,*
30 *Pasturella, Peptococcus, Peptostreptococcus, Plesiomonas, Propionibacterium, Proteus, Providencia, Pseudomonas, Salmonella, Serraria, Shigella, Staphylococcus, Streptobacillus, Streptococcus, Veillonella, Vibrio and Yersinia species; viruses*

including without limitation adenovirus, enteric adenovirus, adeno associated virus (AAV), influenza virus, parainfluenza virus, orbivirus, coronavirus, encephalomyocarditis virus, enterovirus, ECHO virus (enteric cytopathogenic human orphan virus), coxsackie A group virus, coxsackie B group virus, cytomegalovirus, 5 varicella-zoster virus, papilloma virus, baculovirus, picorna virus, rubella virus, mumps virus, encephalitis virus, SSPE virus, polio virus, measles virus, stomatitis virus, hepatitis virus, rhinovirus, REO virus, rotavirus, vaccinia virus, pig Oasky's disease virus, and retro viruses such as human immunodeficiency virus (HIV) and herpesvirus; protozoans; and small molecules as defined above.

10 In a further embodiment of the invention the evanescent-field is not (or not only) used to excite labels attached to ligands but rather to selectively out-couple light generated near the surface structure.

In a preferred embodiment the support of the present invention or the device of the present invention are used in diagnostic applications. Diagnostic 15 applications typically involve the removal of a specimen from a patient or an animal. Examples of such specimens are blood, urine, sperm, vaginal secretion, stool, sputum, tissue, cells, lymph or the contents of the gastrointestinal tract. The specimen can be applied directly to the support or can be further processed externally by, for example, filtration, enzymatic treatment, mechanical and/or chemical disruption to isolate, e.g. 20 single cells, DNA only, RNA only and/or protein only. In some embodiments the specimen is subcultured prior to the processing step in order to increase the amount and/or detectability of a particular ligand within the specimen. The specimen or the further processed specimen can be mixed with a variety of reagents like, for example, buffers, preservatives or stabilizing agents. Usually the specimen or the further 25 processed specimen is applied to the support as a solution or suspension. However, one or more of the above processing steps, which can be carried out externally, can also be integrated into the support, i.e. occur inside the support. In a preferred embodiment the specimen, in particular a blood sample, is directly applied to the support, preferably to the disc and processed inside the support prior to measuring the binding or unbinding of 30 a ligand comprised in the sample. Such a series of processing steps can, for example, include the lysis of cells, purification and concentration of DNA or RNA, in case of RNA additionally reverse transcription, amplification of target DNA or cDNA,

hybridization with a DNA capture probe, selective washes. An embodiment, in which a large number steps of sample preparation and analysis are carried out within the support, preferably the disc is termed "lab-on-a-chip" or "lab-on-a-disc". The skilled artisan is well aware of a large variety of processes which can be used to prepare (a) ligand(s) for later detection. The skilled person also knows how to select the appropriate sequence of a series of disruption, preparation, purification, concentration, washing and/or amplification steps, which are necessary to allow detection of (a) given ligand(s) within a sample. As pointed out above the support of the present invention can include a variety of additional structures, which allow to carry out the desired processing steps.

10 In diagnostic applications ligands are detected, which are indicative of a disease or a predisposition to a disease. Such ligands include without limitation DNA, RNA or proteins of microorganisms, in particular pathogens, including bacteria, viruses and protozoans as well as intact microorganisms or fragments thereof, and tissues or fragments thereof, cells, antigens, DNA, RNA, peptides or proteins, in particular antibodies in its natural or mutant form of a patient or animal. Based on the ligand that needs to be detected a suitable capture probe can be selected by someone of skill in the art. For cell, virus, protein, peptide or antigen detection suitable capture probes are, for example, antibodies or binding fragments or derivatives thereof. For DNA or RNA suitable capture probes are, for example, DNA or RNA. For nucleic acid detection by hybridization it is usually necessary to heat the support comprising the nucleic acid ligand and the corresponding capture probe. The heating step can be carried out outside of or within the device of the present invention. Thus, the device of the present invention can in a preferred embodiment also include a means of controlling the temperature of the support, preferably a heating means, which allows the hybridization of nucleic acids to take place within the device. Such means of controlling the temperature are known in the art and comprise, for example, Peltier elements and heat sinks. If desired this temperature control means can be used to carry out other reactions alternatively, prior or subsequent to the hybridization, which require a change of temperature, like for example, polymerase chain reactions (PCR), enzymatic digestions or reverse transcriptions. Typically, a target DNA or RNA is amplified via a PCR-reaction prior to hybridization with DNA capture probes. It is also envisioned that the light source of the device itself can be utilized as a heating means alone or in addition to

above temperature control means. Light can also be used to photochemically activate or cross-link molecular species present in the device in particular on or above the surface of the support like, for example, to cross-link two DNA strands one of which is attached to the surface of the support.

5 The incubation of the ligand(s) containing medium with the capture probe(s) can be followed by one or more wash or reaction steps with, for example, buffers, enzyme substrates and/or secondary reagents like, for example, labeled antibodies. The skilled artisan is aware of a variety of appropriate buffers and reagents and knows, for example, how to select for a given capture probe-ligand binding pair, i.e.
10 for a DNA/DNA interaction or for a protein/protein interaction, buffers suitable to remove unspecifically bound ligands. The washing and/or reaction steps can be followed in some embodiments by removal or displacement of liquid medium in the support, preferably in the measuring area by gas. The gas can be any gas or mixture of gases and is preferably, air or an inert gas like, for example, argon or nitrogenous gas.
15 The, thus, lowered refractive index of the medium adjacent to the support will allow TIR to occur at lower β_{TIR} and, consequently, at lower α_{NA} and/or α_{wedge} . This in turn will in particular in embodiments of the invention using a mask in front of an objective lens allow the use of smaller masks and, thus, the generation of a higher energy evanescent-field on the surface of the support and, consequently, a higher sensitivity.

20 To detect optically-active substances in the evanescent-field formed on the surface of the support, in particular to determine the binding or unbinding of a ligand to the surface of the support, more particularly to the capture probes, a wide variety of assay formats well known in the art can be employed like, for example, binding assays, unbinding assays, sandwich assays displacement assays and competition
25 assays. The appropriate assay format will depend on the type of analysis to be performed, the ligand and the capture probe and can be readily chosen by someone of skill in the art. The binding and/or unbinding events in one of the above assaying formats can be detected by a single measurement, repeat measurements, which are separated by discrete time intervals, or by continuous measurement. Repeat
30 measurement and continuous measurement are preferred, if it is desired to dynamically detect the binding and unbinding events over time. The change of signal over time is an indication of the association and dissociation kinetics of the respective binding pair

(capture probe and ligand) and allows rapid and reliable determination of, for example, the concentration of the ligand in the medium.

The following figures are solely meant to further illustrate the invention but are not meant to limit the scope of the invention disclosed herein and claimed in the
5 appended claims. Furthermore, all references cited are incorporated herein by reference.

Fig. 1 shows two sections of support of the present invention with three
10 similarly inclined planes adjacent to each other in a “wedged”
arrangement. Fig. 1A shows an arrangement in which light directed at the
surface of the support at an angle α_{NA} , which is not sufficient to allow
total internal reflection. Accordingly all light is only refracted at the
interface and enters the medium (2) through the support (1). Fig. 1B
15 shows an arrangement in which total internal reflection (TIR) can be
achieved at the interface between the support (1) and the medium (2),
when the angle α_{NA} of the incoming beam exceeds the value $\beta_{TIR} - \alpha_{wedge}$,
wherein β_{TIR} is the critical angle, given by the equation $\beta_{TIR} =$
 $\arcsin(n_{medium}/n_{support})$. This critical angle is approximately 56 degrees for
20 a typical set up in which the support is made of polycarbonate ($n_{disc} =$
1.6) and the medium is water ($n_{medium} = 1.33$). The part of the light beam
for which above condition is met, will exhibit TIR (5), whereas the rest is
being refracted and transmitted into the medium. Only if the condition
 $\alpha_{wedge} - |\alpha_{NA}| > \beta_{TIR}$ is met for the complete beam, then all of the beam
will exhibit TIR at the polycarbonate/water interface.

25 Fig. 2 shows the light path of light directed at the support, which has a
focal point behind the surface of the support. The distance of the focal
point from the surface of the support is “x” also termed the amount of
“defocus”, the depth of the inclined plane is “ δ ”, the angle of inclination
of the plane is “ α_{wedge} ”, “ α_{TIRMAX} ” and “ α_{TIR} ” are the bounding angles
30 for which total internal reflection occurs at the surface of the inclined
plane and “ l_{TIR} ” is the length of TIR on the inclined plane, i.e. the TIR
active area length. The light is directed through the support (1) to the

support medium interface, undergoes TIR and generates an evanescent-field (5) in the medium (2).

Fig. 3 shows an example in which an additional tracking layer is provided in the support which allows the correct alignment of the light with the inclined planes on the surface of the support, even so the beam is “defocused”, i.e. has its focal point in the tracking layer within the support. To decrease the amount of light refracted and transmitted into medium (2) an additional intermediate plane is positioned adjacent to the first inclined plane parallel to the lower surface and is provided with a reflective coating (50). The light is directed through a first support structure (11) comprising tracking signals (12) and a second support structure (13) forming the inclined planes on the surface of the support (1). The condition $\alpha_{\text{wedge}} - |\alpha_{\text{NA}}| > \beta_{\text{TIR}}$ is met for all parts of the beam directed at the inclined planes and the part of the beam for which this condition is not met will be reflected back towards the light source at the intermediate plane.

Fig. 4 shows an example where the disc/medium interface is being irradiated by a focussed beam, generated by an objective lens (3). In front of the objective lens an obstructing mask (4) is positioned, such that only those rays are being transmitted that fulfil the condition $\alpha_{\text{NA}} > \beta_{\text{TIR}} - \alpha_{\text{wedge}}$. As a result, no direct refracted light is transmitted into the medium. Only an evanescent wave is coupled into the medium, being located very close ($< \lambda$) to the surface (5). The internally reflected beam resulting from the TIR has not been drawn.

Fig. 5 shows an example where the wedge shaped structure has been replaced by a symmetric pyramidal shaped structure. The support/medium interface is being irradiated by two focussed beams, generated by an objective lens (3). In front of the objective lens an obstructing mask (4) is positioned, such that only those rays of the two beams are being transmitted that fulfil the condition $\alpha_{\text{NA}} > \beta_{\text{TIR}} - \alpha_{\text{wedge}}$. In this case TIR occurs at both inclined planes within one measuring area, thereby doubling the total power enclosed in the evanescent-fields

formed (5). Furthermore, diffraction at the pyramidal structure gives rise to a symmetric (push-pull) tracking signal for radial tracking of the optical disc. The objective lens NA and size of the mask is determined by the pyramidal wedge angle α_{wedge} and the critical angle β_{TIR} . In this arrangement measures may need to be taken to avoid transmission of the excitation beam into the fluid after TIR, e.g. by applying absorbing or reflecting coatings at the right locations.

Fig. 6 shows the same set-up as figure 5, however the objective lens has been modified such that a central part lens (31), which is partly covered by an obstructive mask (4) provides the light beam eliciting the evanescent-field and is used for the generation of tracking signals, whereas an additional higher-numerical aperture (NA) lens (32) collects the photons emitted by fluorescence of molecules excited by the evanescent-fields (5). As a result the system has a larger acceptance angle, thereby increasing the detection efficiency. The low NA (i) is used for sampling and tracking, while the high NA (i) is used for detection. In case of fluorescence detection, the collection of fluorescence light can also be done by an optical system on the opposite side of the disc.

Fig. 7 shows readout of the support using conventional near field coupling, where the objective lens (6), preferably a near field objective lens, with an $\text{NA} > 1.33$ is in close contact ($< \lambda$) with the optical disc. The medium (74) preferably is water with $n = 1.33$. A gold film (73) is applied for reflection. The support preferably comprises a polycarbonate (PC) replicated structure comprising the inclined planes (72) and a glass or PC substrate (71) ($n_{\text{support}} = 1.5$ and 1.6 , respectively). As a result a high readout NA can be realized at the support/medium interface. As long as the NA does not exceed the refractive index n_{medium} , light is being transmitted at the plastic/water interface and no TIR occurs. For numerical apertures greater than this critical $\text{NA}_{\text{crit}} (=n_{\text{medium}})$ total internal reflection occurs at the polycarbonate replicated structure, giving rise to an evanescent wave coupling into the water medium (see Figure 8).

Fig. 8 shows an embodiment of the present invention in which the numerical aperture of objective lens exceeds the critical NA. For entrance angles greater than NA_{min} the incoming light at the support/medium interface is being totally internal reflected (the support contains the wedge structures), giving rise to evanescent wave coupling into the medium. The support comprises a polycarbonate (PC) replicated structure comprising the inclined planes (72) and a glass or PC substrate (71) ($n_{disc} = 1.5$ and 1.6 , respectively). Instead of a gold layer the surface of the wedge structure is coated with a capture probe layer (73). The medium (74) preferably is water with $n = 1.33$.

Fig. 9 shows an optical recording set-up for readout of the support. Fig. 9A shows the light path (21) from laser (10) to disc (70) in which a collimator (30), a splitter (40), a mask (4) and an objective (6) are arranged. The support material (71) and (72) to which a capture probe (73) is attached, is arranged towards the laser, while the medium containing the ligand (74) is arranged on the opposite side. The set-up includes the obstructive mask (4) for selecting entrance angles such that only those rays are transmitted that give rise to TIR at the disc/medium interface. Fig. 9B shows the return light path (22) from support to detector. A dichroic mirror (42) may be arranged for distinguishing between the directly reflected/diffracted light (222) directed to the servo (82) and the (red-shifted) fluorescence (221) from excited surface molecules directed to the detector (81).

Fig. 10 shows an alternative arrangement to the one shown in Fig 9 in which a dichroic structure or polarization sensitive mask (4) is used instead of an obstructive mask. As a result all of the reflected fluorescent light that is being emitted in a cone with opening angle equal to the objective NA, is being collected and detected.

Fig. 11 shows an arrangement of the surface structure of a disc. The areas comprising the inclined planes are structured as channels that extend radial from the center of the disc (A) or structured in circles arranged azimuthal around the center of the disc (B).

CLAIMS:

1. Support comprising two essentially parallel surfaces for the detection of optically-active substances within an evanescent-field formed on the surface of the support, in which in at least one area a plane of said surface is inclined with respect to the plane of the support by an angle α_{wedge} from 10° to 85° .
- 5 2. Support according to claim 1, comprising at least 10, preferably at least 100 areas.
3. Support according to claim 1 or 2, wherein said surface, at which the
10 detection of the optically-active substances takes place is covered by a top plate.
4. Support according to one of claims 1 to 3, wherein α_{wedge} is between 15° and 75° , preferably between 25° and 65° .
- 15 5. Support according to one of claims 1 to 4, wherein the refractive index of the support (n_{support}) is larger than 1.0 and smaller than 2.0, preferably between about 1.4 and 1.8.
6. Support according to one of claims 1 to 5, wherein within the area on
20 said surface a second plane of the surface adjacent to the first inclined plane is inclined in such that a symmetrical pyramidal structure is formed.
7. Support according to one of claims 1 to 6, wherein at least one capture probe is attached to the surface of the inclined plane.

8. Support according to one of claims 1 to 7, wherein the capture probe is selected from the group comprising proteins, in particular antibodies, receptors, enzymes, signaling proteins or fragments thereof; peptides; polysaccharides, nucleic acids, in particular ssDNA, dsDNA and RNA; nucleic acid analogs, in particular PNA;
5 and small molecules.
9. Support according to one of claims 1 to 8, wherein the support further comprises reagents and/or buffers.
- 10 10. Support according to one of claims 1 to 9, wherein the support is an optical disc.
11. Kit comprising a support according to claims 1 to 10 and reagents and/or buffers.
15
12. Device for the detection of optically-active substances within the evanescent-field formed at the surface of a support comprising: a) at least one light source emitting essentially monochromatic light of at least one wavelength, and b) at least one detector means, wherein the at least one light source is arranged in such that it
20 is opposite to the surface of a support, where the detection of the optically-active substance occurs once the support is placed into the device.
13. Device according to claim 12, wherein the detector means is arranged on the same side as the light source.
25
14. Device according to one of claims 12 to 13, wherein the light source generates essentially monochromatic light.
15. Device according to one of claims 12 to 14, comprising at least two light
30 sources generating essentially monochromatic light of at least two different wavelengths.

16. Device according to one of claims 12 to 15, wherein a filter is arranged within the light path of the light source.
- 5 17. Device according to one of claims 12 to 15, wherein an objective lens is used to focus the light of the light source on the support.
18. Device according to claim 17, wherein a mask is placed in the light path between the light source and the mask, which essentially blocks all light directed at the
10 support with an angle α_{NA} smaller than $\arcsin(n_{\text{medium}}/n_{\text{support}}) - \alpha_{\text{wedge}}$.
19. Device according to one of claims 12 to 18, wherein the device further comprises a support according to one of claims 1 to 10.
- 15 20. Device according to claim 19, wherein the support is an optical disc.
21. Device according to claims 19 or 20, wherein the wavelength of the light emitted from the light source, the angle α_{wedge} of the inclined plane(s) of the surface of the support α_{NA} of the light directed at the disc, n_{support} and n_{medium} is (are) selected in
20 such that the depth d of an evanescent-field, which is formed in a medium comprising the optically active substance applied to the support is between 10 nm and 1 μm , preferably between about 20 nm and 200 nm.
22. Use of a support according to one of claims 1 to 10, a kit according to
25 claim 11, and/or of a device according to one of claims 12 to 21 for the detection of at least one optically-active substance within the evanescent-field formed at a surface of the support.
23. Use according to claim 22, wherein the optically-active substance is
30 detected by fluorescence, optical scattering, and/or reflectance modulation.

24. Use according to claim 22 or 23, wherein the optically-active substance comprises a ligand labeled with a fluorescence label, a scattering label, and/or a reflectance modulator.
- 5 25. Use according to one of claims 22 to 24, wherein the optically-active substance or the ligand is contained in blood, urine, sperm, vaginal secretion, stool, sputum, tissue, single cells, lymph and/or the contents of the gastrointestinal tract or derived thereof.
- 10 26. Use according to one of claims 22 to 25, wherein the binding or unbinding of the optically-active substance to the surface of the support is detected.

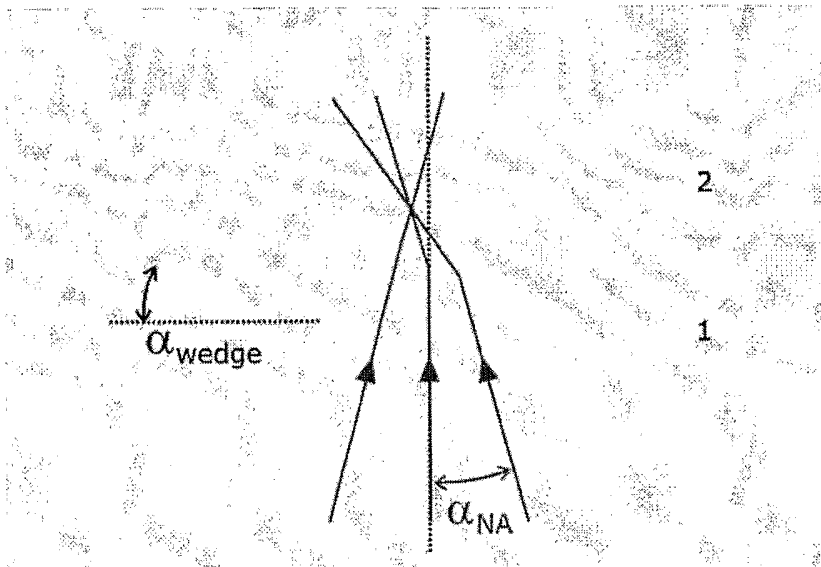

FIG.1a

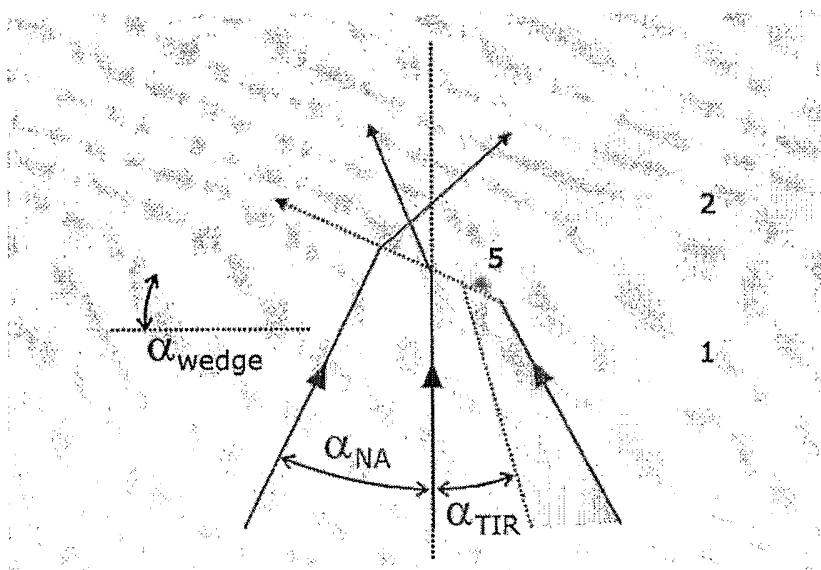

FIG.1b

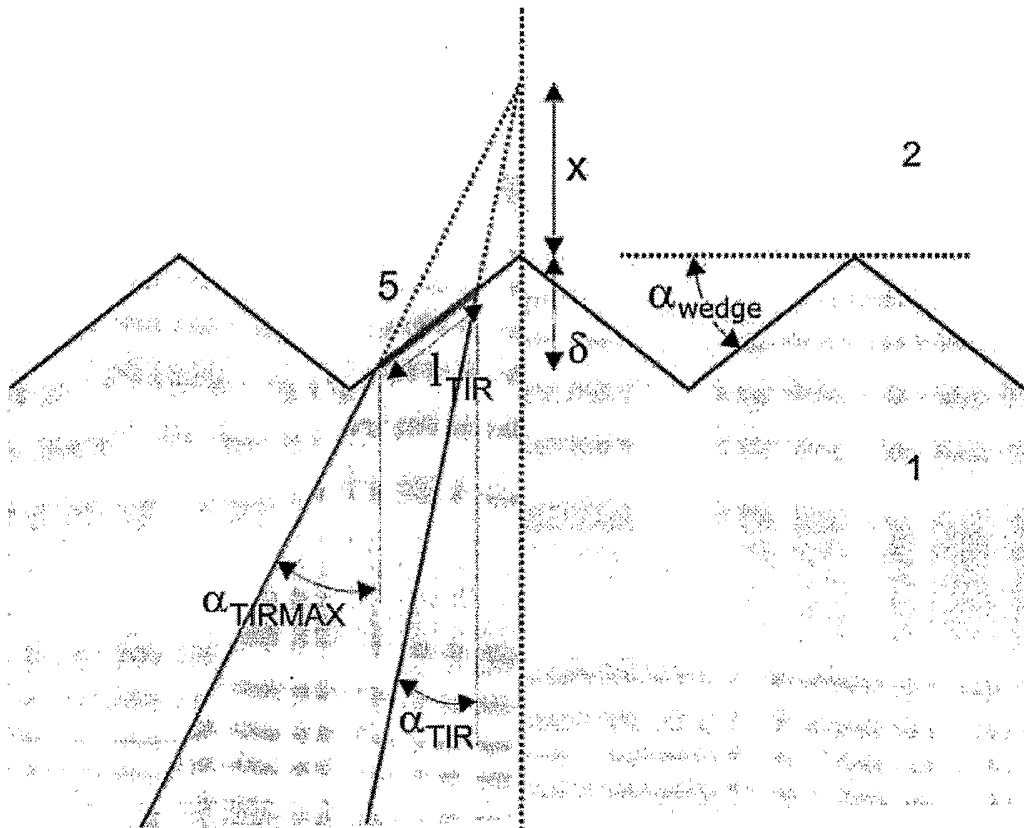

FIG.2

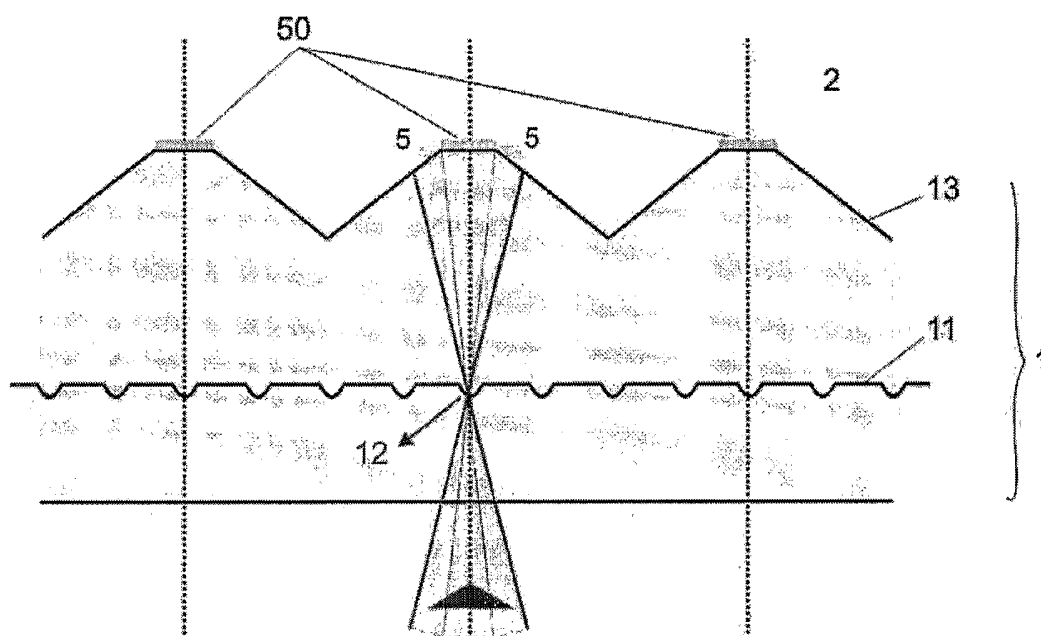

FIG.3

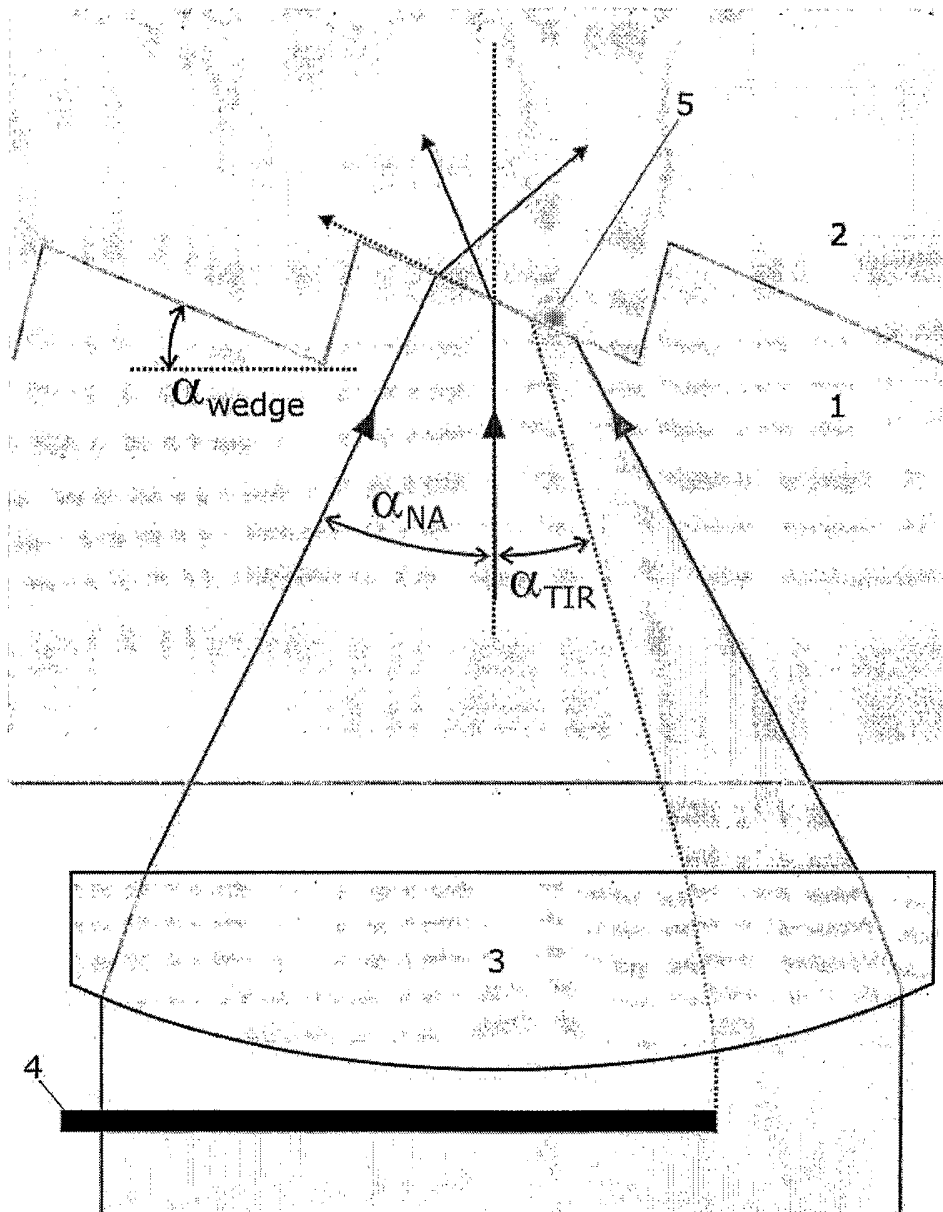

FIG.4

5/11

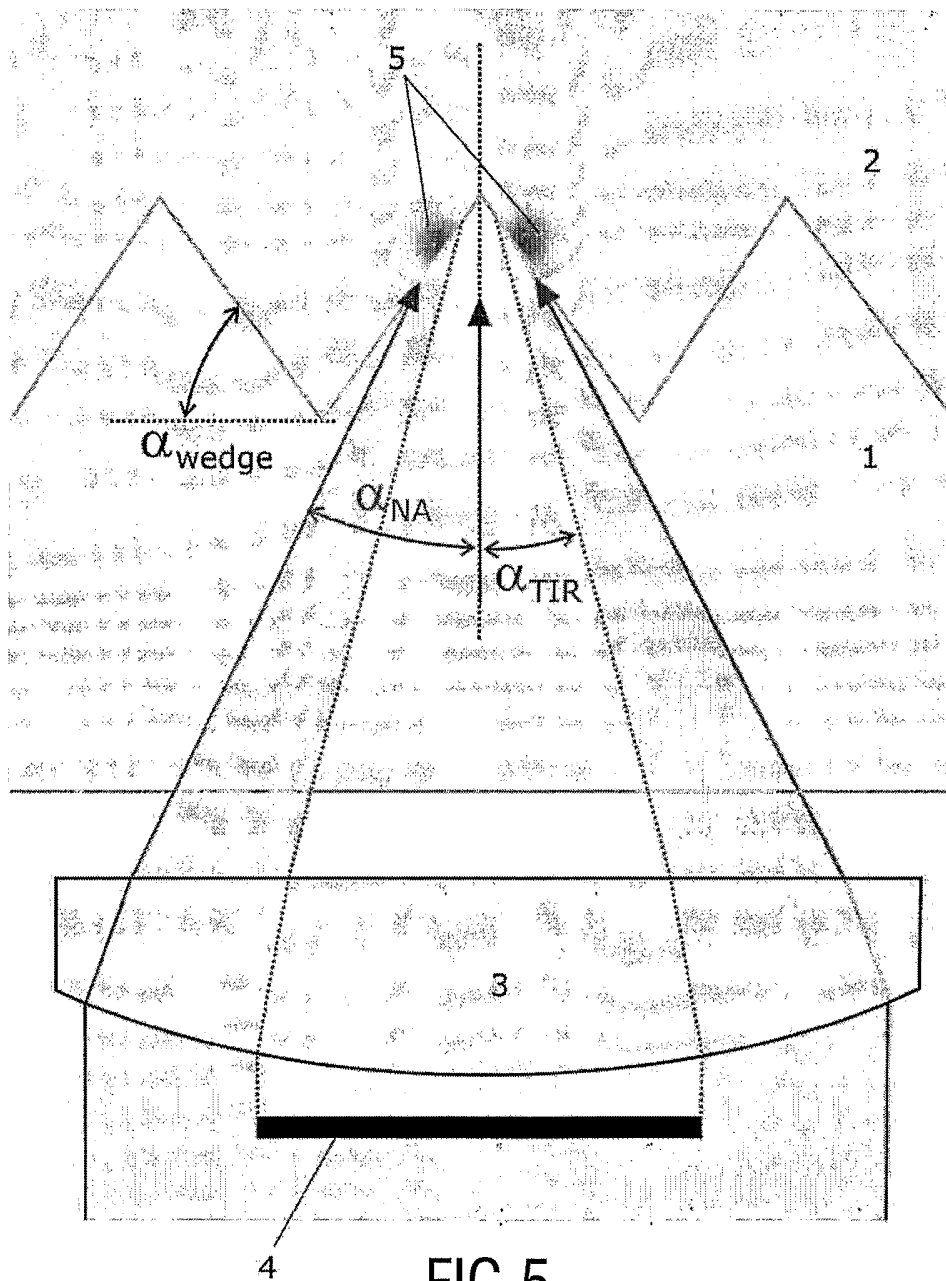

FIG.5

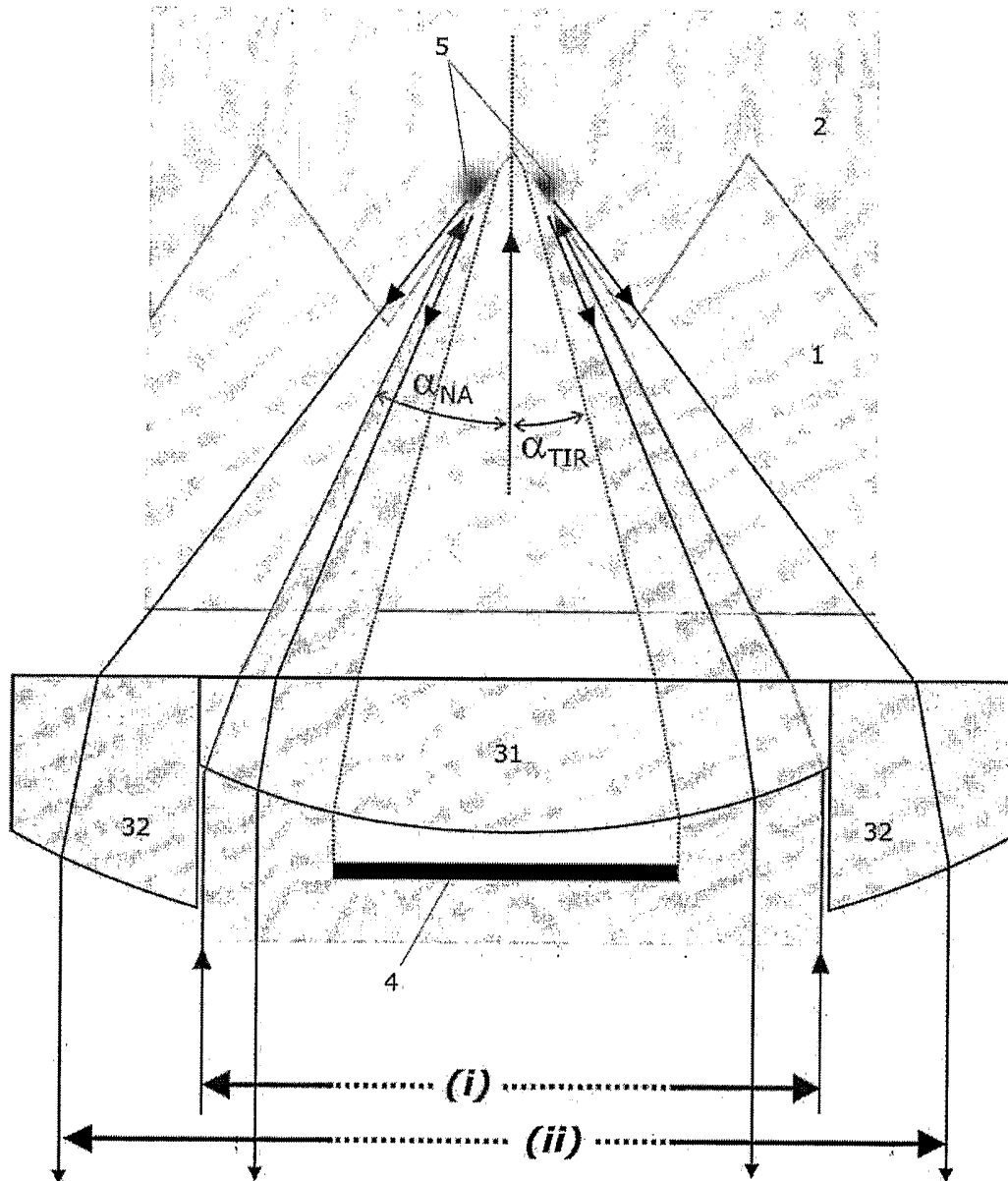

FIG.6

7/11

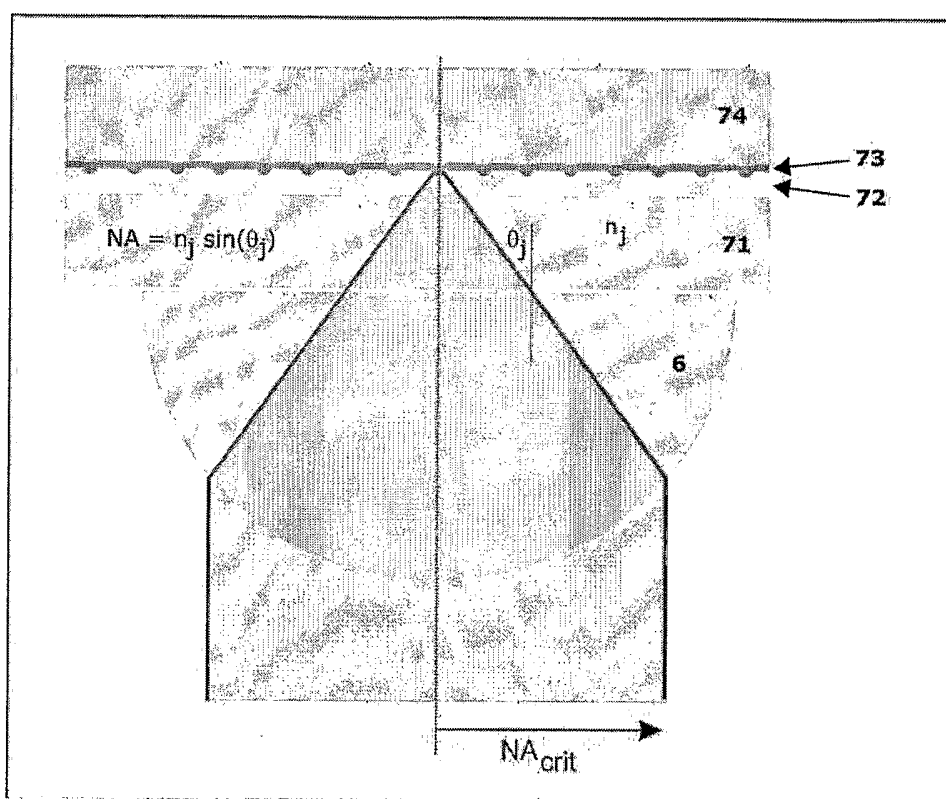

FIG.7

8/11

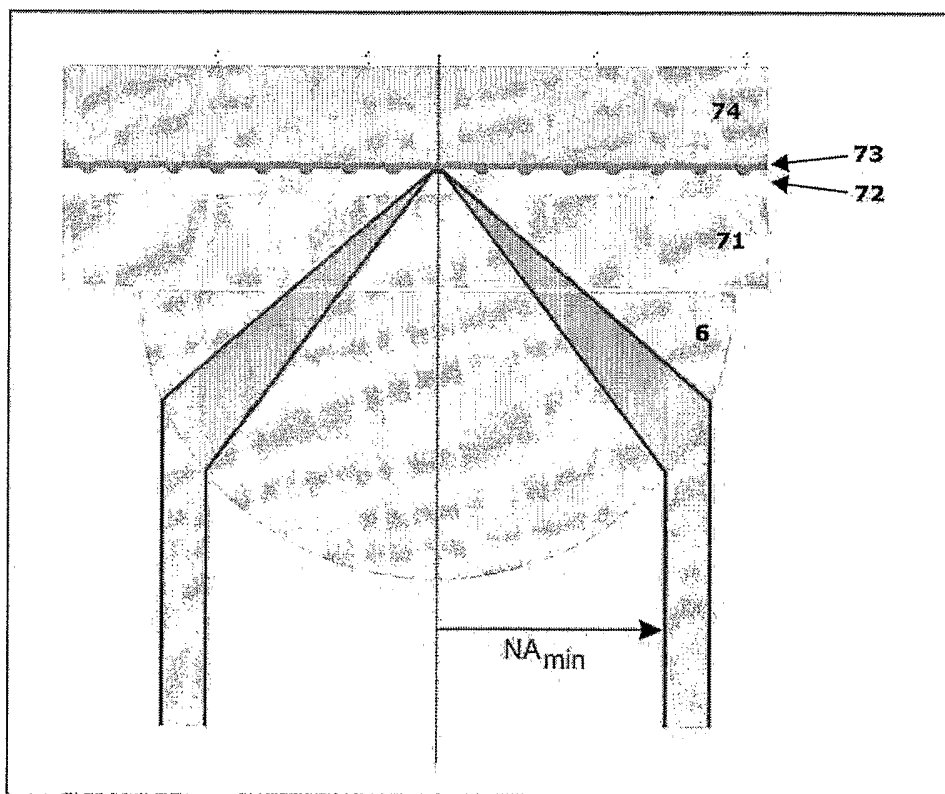

FIG.8

9/11

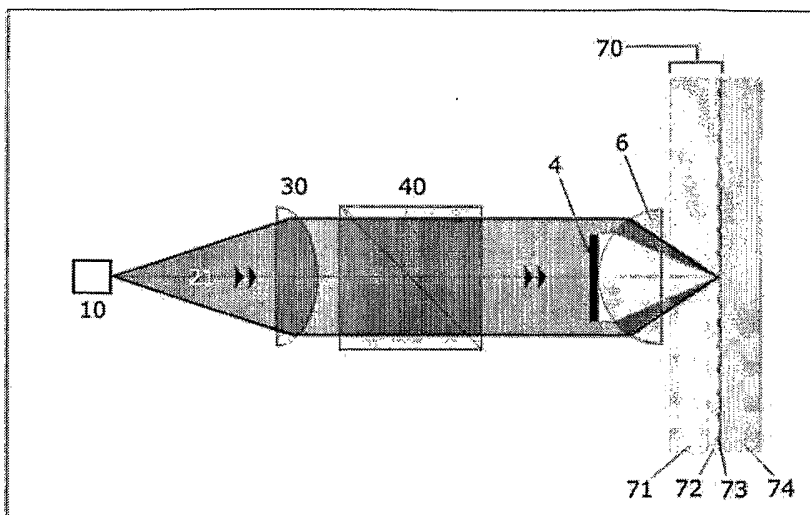

FIG. 9a

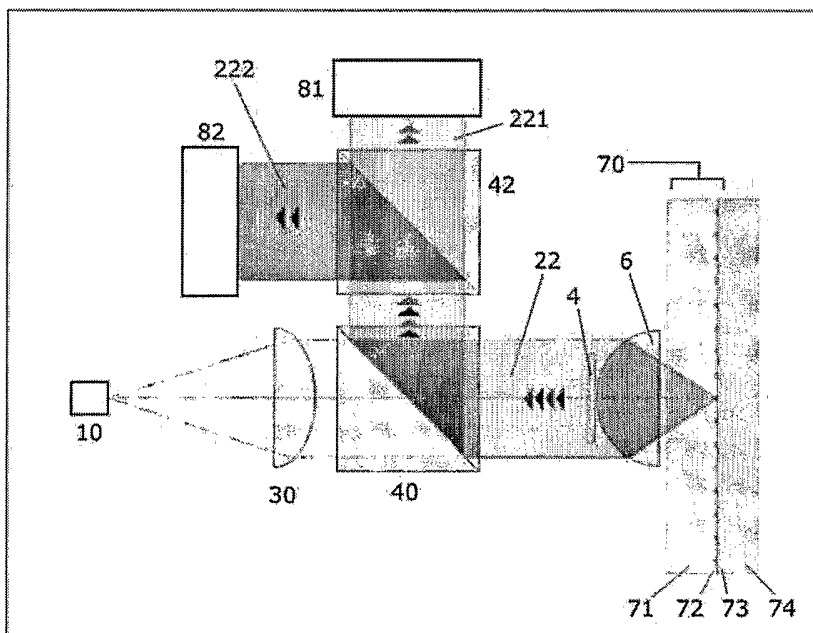

FIG. 9b

10/11

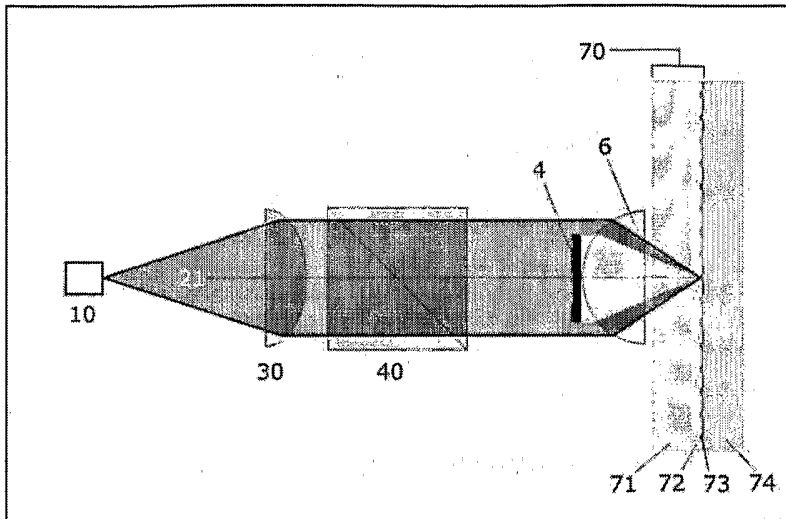

FIG. 10a

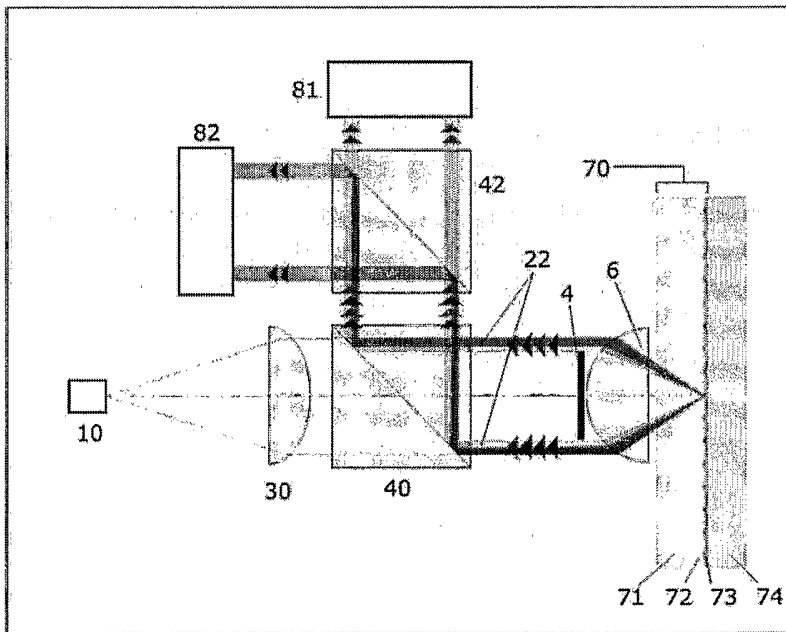

FIG. 10b

11/11

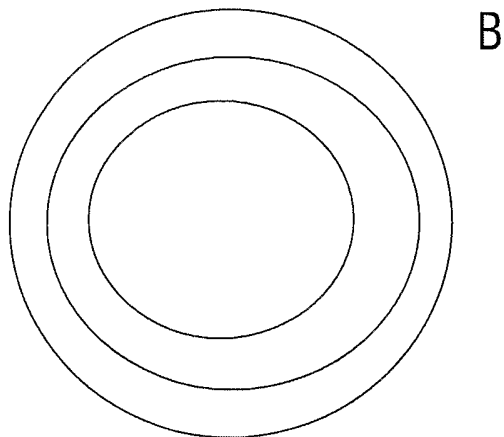
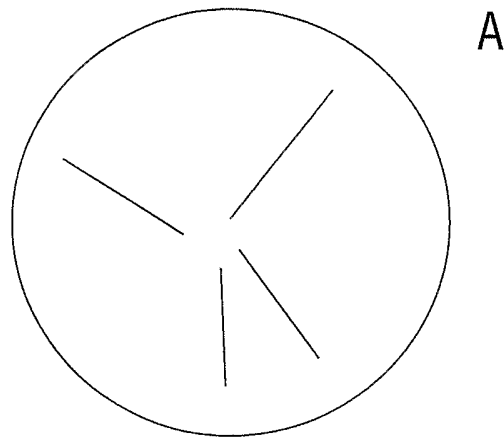

FIG.11

INTERNATIONAL SEARCH REPORT

International Application No
PCT/IB2004/050895

A. CLASSIFICATION OF SUBJECT MATTER
 IPC 7 G01N21/55 G01N33/543 G01N35/00 B01L3/00

According to International Patent Classification (IPC) or to both national classification and IPC

B. FIELDS SEARCHED

Minimum documentation searched (classification system followed by classification symbols)
 IPC 7 G01N B01L

Documentation searched other than minimum documentation to the extent that such documents are included in the fields searched

Electronic data base consulted during the international search (name of data base and, where practical, search terms used)
 EPO-Internal, WPI Data, PAJ, INSPEC

C. DOCUMENTS CONSIDERED TO BE RELEVANT

Category °	Citation of document, with indication, where appropriate, of the relevant passages	Relevant to claim No.
X	US 5 006 716 A (HALL DENNIS G) 9 April 1991 (1991-04-09) column 4, line 59 -column 7, line 16; figures 1,2	1, 2, 4-8, 12-14, 19, 22-24
X	US 2002/135780 A1 (NEUSCHAEFER DIETER ET AL) 26 September 2002 (2002-09-26) paragraphs '0002!', '0017!', '0034!', '0035!', '0038!', '0039!', '0041!'-'0043!', '0046!', '0049!', '0051!', '0053!', '0070!', '0106!', '0107!' paragraphs '0109!', '0110!', '0169!', '0171!'-'0173!', '0186!'; figures 1-3, 4B, 8E, 8F	1-3, 5-15, 17, 19-26

Further documents are listed in the continuation of box C. Patent family members are listed in annex.

° Special categories of cited documents :

A document defining the general state of the art which is not considered to be of particular relevance	*T* later document published after the international filing date or priority date and not in conflict with the application but cited to understand the principle or theory underlying the invention
E earlier document but published on or after the international filing date	*X* document of particular relevance; the claimed invention cannot be considered novel or cannot be considered to involve an inventive step when the document is taken alone
L document which may throw doubts on priority claim(s) or which is cited to establish the publication date of another citation or other special reason (as specified)	*Y* document of particular relevance; the claimed invention cannot be considered to involve an inventive step when the document is combined with one or more other such documents, such combination being obvious to a person skilled in the art.
O document referring to an oral disclosure, use, exhibition or other means	*&* document member of the same patent family
P document published prior to the international filing date but later than the priority date claimed	

Date of the actual completion of the international search 9 September 2004	Date of mailing of the international search report 23/09/2004
---	--

Name and mailing address of the ISA European Patent Office, P.B. 5818 Patentlaan 2 NL - 2280 HV Rijswijk Tel. (+31-70) 340-2040, Tx. 31 651 epo nl, Fax: (+31-70) 340-3016	Authorized officer Duijs, E
--	------------------------------------

INTERNATIONAL SEARCH REPORT

International Application No
PCT/IB2004/050895

C.(Continuation) DOCUMENTS CONSIDERED TO BE RELEVANT		
Category *	Citation of document, with indication, where appropriate, of the relevant passages	Relevant to claim No.
X	<p>US 5 442 448 A (KNOLL WOLFGANG) 15 August 1995 (1995-08-15)</p> <p>column 3, line 1 -column 7, line 62; figures 1,3 column 9, line 5 - line 16; figure 5 column 11, line 25 - line 62; figure 10</p> <p>---</p>	<p>1,2,4, 6-9, 11-14, 19,22-26</p>
X	<p>US 5 846 843 A (SIMON HENRY JOHN) 8 December 1998 (1998-12-08)</p> <p>column 2, line 24 -column 4, line 7; figure 1</p> <p>---</p>	<p>1,4,6-8, 10, 12-14, 16,17, 19,20, 22-24,26</p>
X	<p>US 6 317 206 B1 (WULF JURGEN) 13 November 2001 (2001-11-13)</p> <p>column 4, line 41 -column 5, line 19; figure 1 column 7, line 36 -column 8, line 11; figure 2</p> <p>---</p>	<p>1,3-5, 10, 12-16, 22,23</p>
A	<p>US 5 939 709 A (GHISLAIN LUCIEN P ET AL) 17 August 1999 (1999-08-17) column 14, line 58 - line 62</p> <p>-----</p>	<p>18</p>

FURTHER INFORMATION CONTINUED FROM PCT/ISA/ 210

This International Searching Authority found multiple (groups of) inventions in this international application, as follows:

1. Claims: 1-11,19-26

Support comprising inclined plane(s)

2. Claims: 12-18

Light source and detector

INTERNATIONAL SEARCH REPORT

International application No.
PCT/IB2004/050895

Box II Observations where certain claims were found unsearchable (Continuation of item 2 of first sheet)

This International Search Report has not been established in respect of certain claims under Article 17(2)(a) for the following reasons:

1. Claims Nos.:
because they relate to subject matter not required to be searched by this Authority, namely:

2. Claims Nos.:
because they relate to parts of the International Application that do not comply with the prescribed requirements to such an extent that no meaningful International Search can be carried out, specifically:

3. Claims Nos.:
because they are dependent claims and are not drafted in accordance with the second and third sentences of Rule 6.4(a).

Box III Observations where unity of invention is lacking (Continuation of item 3 of first sheet)

This International Searching Authority found multiple inventions in this international application, as follows:

see additional sheet

1. As all required additional search fees were timely paid by the applicant, this International Search Report covers all searchable claims.
2. As all searchable claims could be searched without effort justifying an additional fee, this Authority did not invite payment of any additional fee.
3. As only some of the required additional search fees were timely paid by the applicant, this International Search Report covers only those claims for which fees were paid, specifically claims Nos.:
4. No required additional search fees were timely paid by the applicant. Consequently, this International Search Report is restricted to the invention first mentioned in the claims; it is covered by claims Nos.:

Remark on Protest

- The additional search fees were accompanied by the applicant's protest.
- No protest accompanied the payment of additional search fees.

INTERNATIONAL SEARCH REPORT

Information on patent family members

International Application No
PCT/IB2004/050895

Patent document cited in search report		Publication date	Patent family member(s)	Publication date
US 5006716	A	09-04-1991	NONE	
US 2002135780	A1	26-09-2002	US 2004115825 A1	17-06-2004
			US 2004115826 A1	17-06-2004
			AU 5824300 A	22-01-2001
			CN 1369059 T	11-09-2002
			WO 0102839 A1	11-01-2001
			EP 1192448 A1	03-04-2002
			JP 2003503732 T	28-01-2003
			US 6707561 B1	16-03-2004
US 5442448	A	15-08-1995	DE 4310025 A1	29-09-1994
			AT 219243 T	15-06-2002
			DE 59410136 D1	18-07-2002
			EP 0618441 A2	05-10-1994
			ES 2176211 T3	01-12-2002
			JP 2084421 C	23-08-1996
			JP 6300530 A	28-10-1994
			JP 7117381 B	18-12-1995
US 5846843	A	08-12-1998	NONE	
US 6317206	B1	13-11-2001	DE 19815109 A1	07-10-1999
			EP 0947823 A2	06-10-1999
			JP 3187386 B2	11-07-2001
			JP 11326209 A	26-11-1999
US 5939709	A	17-08-1999	DE 19882527 T0	25-05-2000
			JP 2002512697 T	23-04-2002
			WO 9858288 A1	23-12-1998