

CORRECTED VERSION

(19) World Intellectual Property Organization
International Bureau



(43) International Publication Date
10 July 2008 (10.07.2008)

PCT

(10) International Publication Number
WO 2008/083190 A2

- (51) International Patent Classification:
A61L 31/02 (2006.01) A61L 31/14 (2006.01)
- (21) International Application Number:
PCT/US2007/088888
- (22) International Filing Date:
27 December 2007 (27.12.2007)
- (25) Filing Language: English
- (26) Publication Language: English
- (30) Priority Data:
60/877,693 28 December 2006 (28.12.2006) US
- (71) Applicant (for all designated States except US): BOSTON SCIENTIFIC SCIMED, INC. [US/US]; One SciMed Place, Maple Grove, Minnesota 55311-1566 (US).
- (72) Inventors; and
(75) Inventors/Applicants (for US only): ATANASOSKA, Liliana [US/US]; 5209 Windsor Avenue, Edina, Minnesota 55436 (US). WEBER, Jan [NL/NL]; Holdaal 49, NL-6228 GJ Maastricht (NL). WARNER, Robert W. [US/US]; 1665 Lamplight Drive, Woodbury, Minnesota 55125 (US).
- (74) Agent: WHELAN, Dorothy P.; Fish & Richardson P.C., P.O. Box 1022, Minneapolis, Minnesota 55440-1022 (US).
- (81) Designated States (unless otherwise indicated, for every kind of national protection available): AE, AG, AL, AM, AO, AT, AU, AZ, BA, BB, BG, BH, BR, BW, BY, BZ, CA, CH, CN, CO, CR, CU, CZ, DE, DK, DM, DO, DZ, EC, EE, EG, ES, FI, GB, GD, GE, GH, GM, GT, HN, HR, HU, ID, IL, IN, IS, JP, KE, KG, KM, KN, KP, KR, KZ, LA, LC, LK, LR, LS, LT, LU, LY, MA, MD, ME, MG, MK, MN, MW, MX, MY, MZ, NA, NG, NI, NO, NZ, OM, PG, PH, PL, PT, RO, RS, RU, SC, SD, SE, SG, SK, SL, SM, SV, SY, TJ, TM, TN, TR, TT, TZ, UA, UG, US, UZ, VC, VN, ZA, ZM, ZW.
- (84) Designated States (unless otherwise indicated, for every kind of regional protection available): ARIPO (BW, GH, GM, KE, LS, MW, MZ, NA, SD, SL, SZ, TZ, UG, ZM, ZW), Eurasian (AM, AZ, BY, KG, KZ, MD, RU, TJ, TM), European (AT, BE, BG, CH, CY, CZ, DE, DK, EE, ES, FI, FR, GB, GR, HU, IE, IS, IT, LT, LU, LV, MC, MT, NL, PL, PT, RO, SE, SI, SK, TR), OAPI (BF, BJ, CF, CG, CI, CM, GA, GN, GQ, GW, ML, MR, NE, SN, TD, TG).
- Published:
— without international search report and to be republished upon receipt of that report
- (48) Date of publication of this corrected version:
4 September 2008
- (15) Information about Correction:
see Notice of 4 September 2008

(54) Title: BIOERODIBLE ENDOPROSTHESES AND METHODS OF MAKING SAME

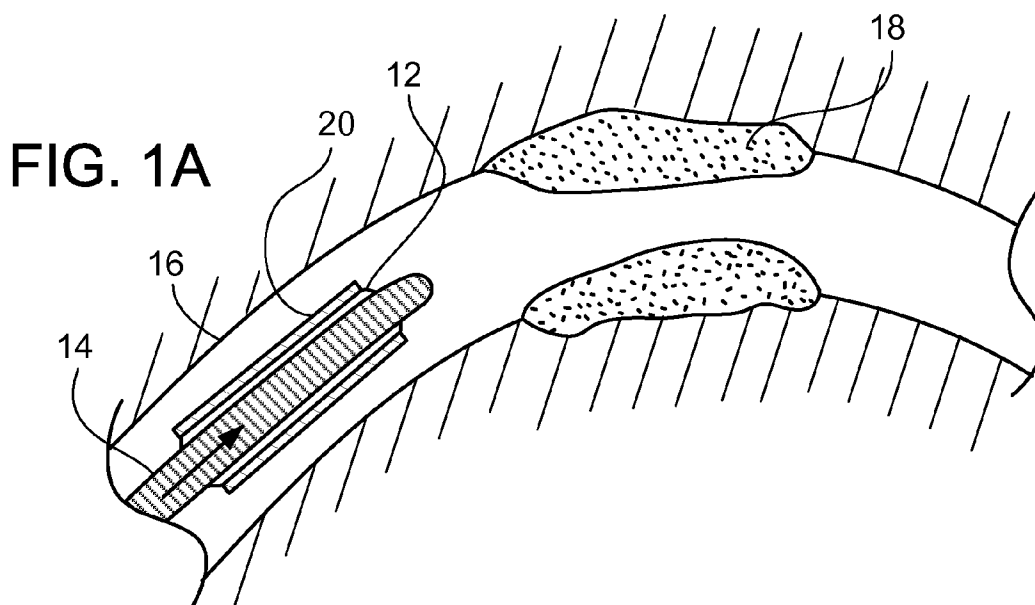

(57) Abstract: A bioerodible endoprosthesis erodes by galvanic erosion that can provide, e.g., improved endothelialization and therapeutic effects.

WO 2008/083190 A2

BIOERODIBLE ENDOPROSTHESES AND METHODS OF MAKING THE SAME

TECHNICAL FIELD

The invention relates to bioerodible endoprostheses, and to methods of making the
5 same.

BACKGROUND

The body includes various passageways such as arteries, other blood vessels, and
other body lumens. These passageways sometimes become occluded or weakened. For
10 example, the passageways can be occluded by a tumor, restricted by plaque, or weakened by
an aneurysm. When this occurs, the passageway can be reopened or reinforced with a
medical endoprosthesis. An endoprosthesis is typically a tubular member that is placed in a
lumen in the body. Examples of endoprostheses include stents, covered stents, and stent-
grafts.

15 Endoprostheses can be delivered inside the body by a catheter that supports the
endoprosthesis in a compacted or reduced-size form as the endoprosthesis is transported to a
desired site. Upon reaching the site, the endoprosthesis is expanded, e.g., so that it can
contact the walls of the lumen.

The expansion mechanism may include forcing the endoprosthesis to expand radially.
20 For example, the expansion mechanism can include the catheter carrying a balloon, which
carries a balloon-expandable endoprosthesis. The balloon can be inflated to deform and this
to secure the expanded endoprosthesis at a predetermined position in contact with the lumen
wall. The balloon can then be deflated, and the catheter withdrawn from the lumen.

It is sometimes desirable for an implanted endoprosthesis to erode over time within
25 the passageway. For example, a fully erodible endoprosthesis does not remain as a permanent
object in the body, which, in turn, may help the passageway recover to its natural condition.
Erodible endoprostheses can be formed from, e.g., a polymeric material, such as polylactic
acid, or from a metallic material, such as magnesium, iron or an alloy thereof.

SUMMARY

The invention relates to bioerodible endoprostheses and methods of making the endoprostheses. The endoprostheses can be configured to erode in a controlled and predetermined manner in the body.

5 According to one aspect of the disclosure, a bioerodible endoprosthesis comprises a relatively electronegative material and a relatively electropositive material between which a galvanic cell is formed, and a current-controlling coating overlying at least a portion of the endoprosthesis effective to modulate the current or current density of the galvanic cell as the endoprosthesis degrades.

10 Preferred implementations of this aspect of the disclosure may include one or more of the following additional features. The current-controlling coating controls exposure of at least one of the electronegative material and the electropositive material to body fluid. The current-controlling coating has a variable thickness, erosion rate, and/or porosity. The thickness of the current-controlling coating varies along the axis of the stent, e.g. linearly or
15 non-linearly, e.g. parabolically. The current density increases as a function of time. The current-controlling coating is a polymer, ceramic or metal. The endoprosthesis has a body comprising substantially electronegative material. The electropositive material is provided as a coating on the body. The endoprosthesis has a body including electropositive and electronegative material, and the concentration of each of the electropositive and
20 electronegative material varies along a length of the body. The endoprosthesis comprises a plurality of sections providing a different current or current density, the sections lying along a length of the endoprosthesis. The sections may be substantially sequentially exposed to body fluid over time.

 According to another aspect of the disclosure, an endoprosthesis comprises a cathode
25 region and an anode region between which a galvanic cell is formed when the endoprosthesis is implanted in the body, and the anode region is degraded by galvanic corrosion such that current density generated by the galvanic cell is maintained between ± 10 percent during degradation of between about 5 percent to about 50 percent by weight of the anode region.

 Preferred implementations of this aspect of the disclosure may include one or more of
30 the following additional features. The endoprosthesis undergoes both galvanic corrosion and bioerosion. Both the cathode region and the anode region are bioerodible. The current density

is sufficient for tumor treatment, restenosis inhibition or promotion of cell proliferation. The cathode region comprises magnesium or magnesium alloy, e.g. the magnesium alloy comprises materials selected from the group consisting of: zinc, aluminum, magnesium, lithium, iron, nickel, copper, and alloys thereof. The cathode region comprises materials
5 selected from the group consisting of: iron, platinum, and gold. The endoprosthesis further comprises a polymer coating. The endoprosthesis further comprises a coating selected from the group consisting of: magnesium oxide, magnesium hydride, and magnesium fluoride. The endoprosthesis erodes from one end toward another end.

According to still another aspect of the disclosure, an erodible endoprosthesis
10 comprises a body including a relatively electronegative material and a relatively electropositive material between which a galvanic cell is formed, the concentration of electronegative and electropositive material varying along a length of the body.

Preferred implementations of this aspect of the disclosure may include one or more of the following additional features. The body is formed of an alloy including the
15 electronegative material and the electropositive material. The body includes a current-controlling layer.

Embodiments may have one or more of the following advantages.

An endoprosthesis erodes by galvanic corrosion, producing a controlled current for therapeutic effect. The endoprosthesis may not need to be removed from a lumen after
20 implantation. The endoprosthesis can have a low thrombogenicity and high initial strength. The endoprosthesis can exhibit reduced spring back (recoil) after expansion. Lumens implanted with the endoprosthesis can exhibit reduced restenosis. The endoprosthesis can be erodible. The rate of erosion of different portions of the endoprosthesis can be controlled, allowing the endoprosthesis to erode in a predetermined manner and reducing, e.g., the
25 likelihood of uncontrolled fragmentation and embolization. For example, the predetermined manner of erosion can be from a first end of the endoprosthesis to a second end of the endoprosthesis. The controlled rate of erosion and the predetermined manner of erosion can extend the time the endoprosthesis takes to erode to a particular degree of erosion, can extend the time that the endoprosthesis can maintain patency of the passageway in which the
30 endoprosthesis is implanted, can allow better control over the size of the released particles

during erosion, and/or can allow the cells of the implantation passageway to better endothelialize around the endoprosthesis.

An erodible or bioerodible endoprosthesis, e.g., a stent, refers to an endoprosthesis, or a portion thereof, that exhibits substantial mass or density reduction or chemical transformation after it is introduced into a patient, e.g., a human patient. Mass reduction can occur by, e.g., dissolution of the material that forms the endoprosthesis, fragmenting of the endoprosthesis, and/or galvanic reaction. Chemical transformation can include oxidation/reduction, hydrolysis, substitution, and/or addition reactions, or other chemical reactions of the material from which the endoprosthesis, or a portion thereof, is made. The erosion can be the result of a chemical and/or biological interaction of the endoprosthesis with the body environment, e.g., the body itself or body fluids, into which the endoprosthesis is implanted and/or erosion can be triggered by applying a triggering influence, such as a chemical reactant or energy to the endoprosthesis, e.g., to increase a reaction rate. For example, an endoprosthesis, or a portion thereof, can be formed of a relatively electronegative metal (e.g., magnesium, iron) and a relatively electropositive metal (e.g., iron, platinum), which upon implantation into a body lumen can undergo galvanic erosion. For example, an endoprosthesis, or a portion thereof, can be formed from an active metal, e.g., Magnesium or Calcium or an alloy thereof, and which can erode by reaction with water, producing the corresponding metal oxide and hydrogen gas (a redox reaction). For example, an endoprosthesis, or a portion thereof, can be formed from an erodible or bioerodible polymer, an alloy, and/or a blend of erodible or bioerodible polymers which can erode by hydrolysis with water. The erosion occurs to a desirable extent in a time frame that can provide a therapeutic benefit. For example, galvanic erosion of the endoprosthesis can release a therapeutic ion such as Mg^{2+} , which can modulate cell growth for better endothelialization of the endoprosthesis. In some embodiments, galvanic erosion provides a therapeutic current, which can be used to treat tumor lesions, promote endothelialization, and/or modulate cell proliferation. For example, the endoprosthesis can exhibit substantial mass reduction after a period of time, when a function of the endoprosthesis, such as support of the lumen wall or drug delivery, is no longer needed or desirable. In particular embodiments, the endoprosthesis exhibits a mass reduction of about 10 percent or more, e.g. about 50 percent or more, after a period of implantation of one day or more, e.g. about 60 days or more, about

180 days or more, about 600 days or more, or 1000 days or less. In embodiments, only portions of the endoprosthesis exhibit erodibility. For example, an exterior layer or coating may be non-erodible, while an interior layer or body is erodible. In some embodiments, the endoprosthesis includes a non-erodible coating or layer of a radiopaque material, which can provide long-term identification of an endoprosthesis location.

Erosion rates can be measured with a test endoprosthesis suspended in a stream of Ringer's solution flowing at a rate of 0.2 ml/second. During testing, all surfaces of the test endoprosthesis can be exposed to the stream. For the purposes of this disclosure, Ringer's solution is a solution of recently boiled distilled water containing 8.6 gram sodium chloride, 0.3 gram potassium chloride, and 0.33 gram calcium chloride per liter of solution.

Other aspects, features and advantages will be apparent from the description of the embodiments thereof and from the claims.

DESCRIPTION OF DRAWINGS

FIGS. 1A-1C are sequential, longitudinal cross-sectional views, illustrating delivery of an endoprosthesis in a collapsed state, expansion of the endoprosthesis, and the deployment of the endoprosthesis in a body lumen.

FIGS. 2A – 2C are sequential, longitudinal cross-sectional views of an endoprosthesis in a body lumen over time.

FIG. 3 is a schematic drawing illustrating a galvanic reaction in a portion of an endoprosthesis.

FIG. 4 is a cross-sectional view of an embodiment of an endoprosthesis.

FIGS. 5A-5C are longitudinal cross-sectional views of an endoprosthesis in a body lumen over time.

FIG. 6 is a cross-sectional view of an embodiment of an endoprosthesis.

FIG. 7 is a cross-sectional view of an embodiment of an endoprosthesis.

FIG. 8A-8C are sequential, longitudinal cross-sectional views of an embodiment of an endoprosthesis in a body lumen over time.

FIG. 9 is a flow chart of an embodiment of a method of making an endoprosthesis.

FIG. 10 illustrates a method of making an endoprosthesis.

FIG. 11 is a flow chart of an embodiment of a method of making an endoprosthesis.

FIG. 12 is a flow chart of an embodiment of a method of making an endoprosthesis.

DETAILED DESCRIPTION

5 Referring to FIGS. 1A-1C, during implantation of an endoprosthesis 10, the endoprosthesis is placed over a balloon 12 carried near a distal end of a catheter 14, and is directed through a lumen 15 (FIG. 1A) until the portion of the catheter carrying the balloon and endoprosthesis reaches the region of an occlusion 18 (FIG. 1B). The endoprosthesis is then radially expanded by inflating balloon 12 and compressed against the vessel wall with
10 the result that occlusion 18 is compressed, and the vessel wall surrounding it undergoes a radial expansion (FIG. 1B). The pressure is then released from the balloon and the catheter is withdrawn from the vessel (FIG. 1C), leaving the endoprosthesis 10 fixed within lumen 16.

Referring to FIGS. 2A-2C, the endoprosthesis 10 erodes over a period of time. For example, in embodiments, the endoprosthesis exhibits substantial mass reduction after a
15 period of time when a function of the endoprosthesis, such as support of the lumen wall or drug delivery, is no longer needed or desirable. Referring particularly to FIGS. 2A-2C, for example, the erosion can progress from one end 22 of an endoprosthesis 20 toward a second end 24, which can, for example, enable the endoprosthesis to maintain patency of a body lumen for a more prolonged period of time, and/or allow increased endothelialization of the
20 endoprosthesis.

Referring particularly to FIG. 3, the endoprosthesis erodes at least in part by galvanic corrosion in a manner that provides a current density magnitude and density uniformity over time to the surrounding tissue, producing a therapeutically beneficial effect. In galvanic corrosion, a galvanic cell 32 is formed that includes a relatively electronegative metal 34,
25 such as magnesium, in contact with a relatively electropositive metal 36, such as platinum. In body fluids, magnesium metal can act as an anode that is oxidized to Mg^{2+} and two electrons. Mg^{2+} can dissolve into the body environment, and the two electrons are transferred to platinum, which acts as a cathode. The electrons are released to the body environment where they react with oxygen and protons or water to form water or hydroxyl ions, respectively.
30 The released magnesium ions can, for example, modulate endothelial cell growth, which can reduce the chance of restenosis, decrease smooth muscle cell growth and treat tumor lesions.

The therapeutic current can have a current density of at least about one mA (e.g., at least about two mA, at least about three mA, at least about four mA, at least five mA, at least six mA, at least seven mA, at least eight mA, or at least about nine mA) and/or at most about ten mA (e.g., at most about nine mA, at most about eight mA, at most about seven mA, at most about six mA, at most about five mA, at most about four mA, at most about three mA, at most about two mA) at a coulomb dosage of at least about $1\text{C}/\text{cm}^2$ (e.g., from about $5\text{C}/\text{cm}^2$, from about $10\text{C}/\text{cm}^2$, from about $20\text{C}/\text{cm}^2$) and/or at most about $25\text{C}/\text{cm}^2$ (e.g., at most about $20\text{C}/\text{cm}^2$, at most $10\text{C}/\text{cm}^2$, at most $5\text{C}/\text{cm}^2$). In some embodiments, the therapeutic current has a current density that is maintained within a desired range for a desired duration.

For example, the current density can be maintained at about \pm two percent (e.g., at about \pm five percent, at about \pm 10 percent, or at about \pm 15 percent) during erosion from about two percent (e.g., from about five percent, from about 10 percent, from about 15 percent, or from about 20 percent) of the endoprosthesis to about 95 percent (e.g., to about 90 percent, to about 80 percent, to about 75 percent, to about 60 percent, to about 50 percent, to about 40 percent, to about 30 percent, to about 20 percent, to about 15 percent, to about 10 percent, or to about five percent) of the endoprosthesis. The effects of magnesium ions on endothelial cells is further described, for example, in Maier *et al.*, *Biochemica et Biophysica Acta*, 1689 (2004), 6-12. The effect of electrical current in treatment of tumor lesions is described, for example, in Nilsson *et al.*, *Bioelectrochemistry and Bioenergetics*, 47 (1998), 11-18; and von Euler *et al.*, *Bioelectrochemistry*, 62 (2004), 57-65. The use of current in modulating cell proliferation is described, for example, in Shi *et al.*, *Biomaterials*, 25 (2004), 2477-2488.

The magnitude, maintenance, and distribution of the current can be controlled by selecting features such as the geometry, cathode to anode area ratio, distance between cathode and anode, surface shape and condition, number of cells, and the application of protective current-controlling coatings. For example, the galvanic current density increases with anode area and decreases with increasing distance from the anode-cathode junction. The decrease in current density with respect to the anode-cathode junction can be non-linear.

Referring to FIG. 4, an endoprosthesis 40 has a body 42, which includes a electronegative metal such as magnesium or a magnesium alloy, a thin layer 46 of electropositive metal, and a current-controlling layer 56. In some embodiments, the endoprosthesis includes a second current-controlling erodible layer 44 covering the body

surface, such that the electropositive metal contacts the electronegative metal at select locations. For example, the electropositive metal directly contacts the electronegative metal at wells 48, to form a galvanic couple. The current controlling layer 56 controls and limits the area of the electronegative body 42 exposed to body fluid as a function of the distance along the endoprosthesis from the electropositive layer 46 to maintain relatively constant current density as the endoprosthesis erodes. The current-controlling layer 56 is an eroding material, e.g. a polymer, and has a thickness that decreases along the endoprosthesis as a function of the distance from the electropositive metal. As current controlling layer 56 erodes, the body 42 is exposed at a predetermined rate that is a function of the layer thickness. Thus, at regions of the stent more remote from the electropositive layer 46, a larger area of the body 42 is exposed and as the body 42 erodes closer to the electropositive layer 46, a smaller surface area of the body 42 is exposed. Layer 56 can cover a junction 50 between the electronegative body and the electropositive metal coating to reduce accelerated galvanic erosion at the junction. The layer 56 can be made of material that erodes more slowly than layer 44, so that the junction is protected until the remainder of the body has eroded.

Referring now to FIGS. 5A, 5B, and 5C, the erosion of the endoprosthesis 40 upon implantation into a body lumen 55 is illustrated. Erosion begins at end 54 and proceeds toward end 52 of the endoprosthesis. The relatively thin coating of polymer at end 54 can substantially erode before erosion of the thicker polymer coating near junction 50, thus gradually exposing the endoprosthesis body to body fluids from end 54 to junction 50. By tailoring the thickness of the bioerodible polymer coating 56, the area of exposure can decrease as erosion proceeds toward junction 50 and can help maintain the current density within a desired range for a desired duration.

The current-controlling layer can have a linear thickness variation, as illustrated, or a non-linear thickness variation, e.g. a parabolic thickness variation along a length of the stent. For example, the galvanic current density can decrease exponentially as a function of increasing distance between the anode and the cathode, for example, as described in Song *et al.*, *Corrosion Science*, 46 (2004), 955-977. The current controlling layer can be erodible, as illustrated above, or non-erodible. A non-erodible coating can control exposure of the stent body to body fluid by, e.g. varying porosity along the length of the stent instead of or in addition to thickness variation. The current controlling layer can be, e.g. a polymer, ceramic,

or metal. The composition of the current controlling layer can vary along the length of the stent. The current controlling layer can also include multiple layers, such as an erodible layer over a porous, non-erodible layer. Different materials, thicknesses and porosities can be used in different regions of the stent, such as the interior surface and the exterior surface.

5 Referring to FIG. 6, an endoprosthesis 80 includes an electronegative erodible body 82 and three sections 84, 86, 88, with varying current characteristics. Each section includes an electropositive metal 92, 92', 92'' and a current controlling layer 94, 94', 94''. The sections are arranged so that the current density is a lower density at the beginning of the endoprosthesis erosion process (e.g., a long galvanic section) to, for example, promote
10 endothelialization, and a higher current density toward the end of the endoprosthesis erosion process (e.g., a short galvanic section) to, for example, decrease smooth muscle cell proliferation.

In particular, section 84 has a relatively large electropositive area 92'' and electronegative surface area, and occupies a relatively long length along the stent. The
15 current-controlling layer 94'' is relatively thin, such that it erodes quickly to expose the electronegative and electropositive metal to body fluid. Section 86 has a smaller electropositive area 92' and electronegative area, a shorter length, and a thicker current controlling layer 94'. Section 88 has a still smaller electropositive area 92 and electronegative area, a shorter length, and a thicker current-controlling layer 94. The sections
20 are exposed substantially sequentially, starting with section 84 and proceeding to section 86 and then section 88, to provide a gradually increasing current density over time.

Referring to FIG. 7, an endoprosthesis 60 has a varying concentration of electronegative metal and electropositive metal along its length. The endoprosthesis has a body formed of an alloy or a composite in which the electronegative metal gradually
25 decreases in concentration from an end 64 toward a second end 66 of the endoprosthesis (shading), while the electropositive metal can gradually increase in concentration from end 64 to end 66. Referring to FIG. 8A, 8B, and 8C, when implanted into a body lumen 61, endoprosthesis 60 can erode via bio-erosion and galvanic erosion. As shown, the endoprosthesis can erode from end 64 toward end 66 over the duration of the lifetime of the
30 endoprosthesis. By tailoring the concentration of the electronegative metal relative to the concentration of the electropositive metal along the length of endoprosthesis, the current

density can be maintained within a desired range for a desired duration. In embodiments, the endoprosthesis can also include one or more current-controlling layers (e.g. layers 68) as discussed above.

For galvanic corrosion, the endoprosthesis includes at least one relatively
5 electronegative metal (e.g., magnesium) and at least one relatively electropositive metal. The relatively electronegative and electropositive metals form a bimetallic couple, which upon immersion in a biological fluid can form a galvanic cell or a bioelectric battery that can erode by galvanic corrosion. In some embodiments, the endoprosthesis body includes one or more relatively electronegative metals in the form of a substantially pure metallic element, an
10 alloy, or a composite. Suitable electronegative metals include metallic elements such as magnesium, iron, zinc, and alloys thereof. Examples of alloys include magnesium alloys, such as, by weight, 50-98% magnesium, 0-40% lithium, 0-5% iron and less than 5% other metals or rare earths; or 79-97% magnesium, 2-5% aluminum, 0-12% lithium and 1-4% rare earths (such as cerium, lanthanum, neodymium and/or praseodymium); or 85-91%
15 magnesium, 6-12% lithium, 2% aluminum and 1% rare earths; or 86-97% magnesium, 0-8% lithium, 2% -4% aluminum and 1-2% rare earths; or 8.5-9.5% aluminum, 0.15%-0.4% manganese, 0.45-0.9% zinc and the remainder magnesium; or 4.5-5.3% aluminum, 0.28%-0.5% manganese and the remainder magnesium; or 55-65% magnesium, 30-40% lithium and 0-5% other metals and/or rare earths. Magnesium alloys are also available under the names
20 AZ91D, AM50A, and AE42. Other erodible materials are described in Bolz, U.S. 6,287,332 (e.g., zinc-titanium alloy and sodium-magnesium alloys); Heublein, U.S. Patent Application 2002000406; Park, *Science and Technology of Advanced Materials*, 2, 73-78 (2001); and Heublein *et al.*, *Heart*, 89, 651-656 (2003), all of which are hereby incorporated by reference herein in their entirety. In particular, Park describes Mg-X-Ca alloys, e.g., Mg-Al-Si-Ca, Mg-
25 Zn-Ca alloys.

Suitable electropositive metals include platinum, gold, iridium, aluminum, steel, zinc, and/or alloys thereof. In some embodiments, the electropositive metal is bioerodible. For example, the electropositive bioerodible metal can be iron and/or zinc. In an endoprosthesis that includes bioerodible electronegative and electropositive metals, the bioerodible
30 electropositive metal can be substantially protected from galvanic corrosion while the electronegative metal undergoes erosion. Once the electronegative metal has eroded, the

bioerodible electropositive metal can itself erode, for example, by oxidation or by bio-erosion processes. The electropositive metal can be radiopaque for compatibility with MRI or fluoroscopic imaging methods. In some embodiments, the relatively electropositive metal has a non-erodible portion that remains in the body lumen after the remaining portions of the endoprosthesis have eroded. The non-erodible portion can provide support for the body lumen in which the endoprosthesis is implanted.

In some embodiments, the electropositive metal is a thin film on a portion of the endoprosthesis. For example, the electropositive metal can have a thickness of at most about 500 nanometers (e.g., at most about 400 nanometers, at most about 300 nanometers, at most about 200 nanometers, at most about 100 nanometers, at most about 80 nanometers, at most about 60 nanometers, at most about 40 nanometers, at most about 20 nanometers, at most about 10 nanometers, at most about five nanometers, at most about two nanometers, or at most about one nanometer) and/or at least about 0.5 nanometer (e.g., at least about one nanometers, at least about two nanometers, at least about five nanometers, at least about 10 nanometers, at least about 20 nanometers, at least about 40 nanometers, at least about 60 nanometers, at least about 80 nanometers, at least about 100 nanometers, at least about 200 nanometers, at least about 300 nanometers, or at least about 400 nanometers). The electropositive metal can have an area of at least about 0.5 mm² (e.g., at least about one mm², at least about two mm², at least about five mm², at least about 10 mm², at least about 20 mm², at least about 30 mm², or at least about 40 mm²) and/or at most about 50 mm² (e.g., at most about 40 mm², at most about 30 mm², at most about 20 mm², at most about 10 mm², at most about five mm², at most about two mm², or at most about one mm²).

In some embodiments, the electropositive metal takes the form of metal clusters on an endoprosthesis body. For example, the electropositive metal can be in a cluster of at least about 10 atoms (e.g., at least about 50 atoms, at least about 100 atoms, at least about 500 atoms, at least about 1,000 atoms, at least about 10,000 atoms) and/or at most about 100,000 atoms (e.g., at most about 10,000 atoms, at most about 1,000 atoms, at most about 500 atoms, at most about 100 atoms, or at most about 50 atoms). The metal cluster can have an area of at least about 1 nm² (e.g., at least about 10 nm², at least about 100 nm², at least about 1,000 nm², at least about 10,000 nm²) and/or at most about 1 μm² (e.g., at most about 10,000 nm², at most about 1,000 nm², at most about 100 nm², or at most about 10 nm²). In some

embodiments, the metal clusters form microarrays on the endoprosthesis. For example, the metal clusters can have a density of from about 10 metal clusters per mm^2 (e.g., about 100 metal clusters per mm^2 , or about 1,000 metal clusters per mm^2) to about 10,000 metal clusters per mm^2 (e.g., about 1,000 metal clusters per mm^2 , or about 100 metal clusters per mm^2) of the surface of the endoprosthesis.

In some embodiments, the electropositive metal occupies a fraction of the endoprosthesis. For example, the electropositive metal can be at least about one percent by weight (e.g., at least about 10 percent by weight, at least about 20 percent by weight, at least about 30 percent by weight, at least about 40 percent by weight, at least about 50 percent by weight, at least about 60 percent by weight, at least about 70 percent by weight, or at least about 80 percent by weight) and/or at most about 90 percent by weight (e.g., at most about 80 percent by weight, at most about 70 percent by weight, at most about 60 percent by weight, at most about 50 percent by weight, at most about 40 percent by weight, at most about 30 percent by weight, at most about 20 percent by weight, or at most about 10 percent by weight) of the endoprosthesis.

In embodiments, the endoprosthesis body includes more than one material, such as different bioerodible materials physically mixed together, multiple layers of different bioerodible materials, and/or multiple sections of different bioerodible materials along a direction (e.g., length) of the tube. For example, the endoprosthesis body can include a mixture of a magnesium alloy in a bioerodible polymer, in which two or more distinct substances (e.g., metals, ceramics, glasses, and/or polymers) are intimately combined to form a complex material. In addition to galvanic corrosion, the endoprosthesis can undergo direct bioerosion of the electropositive, electronegative and/or coating material.

The current controlling layer provides a barrier that limits or prevents exposure of the stent body and/or electropositive material. Suitable materials include oxides, hydrides, or fluorides. Examples of polymers include bioerodible polymers such as polylactic acid (PLA), polylactic glycolic acid (PLGA), polyanhydrides (e.g., poly(ester anhydride)s, fatty acid-based polyanhydrides, amino acid-based polyanhydrides), polyesters, polyester-polyanhydride blends, polycarbonate-polyanhydride blends, and/or combinations thereof. The layer can have a thickness of at least about one nanometer (e.g., at least about 10 nanometers, at least about 100 nanometers, at least about one micrometer, or at least about

five micrometers) and/or at most about 10 micrometers (e.g., at most about five micrometers, at most about one micrometer, at most about 100 nanometers, at most about 10 nanometers). The thickness can be uniform or non-uniform. For example, the thickness can increase from one end of the endoprosthesis to another end in an overall linear manner, an overall non-linear manner (e.g., an overall parabolic increase, an overall exponential increase), or a stepwise manner. The thickness of the polymeric layer at a given location on the endoprosthesis can be correlated with the desired current density. For example, a thicker polymer layer which erodes over a longer period of time can attenuate a relatively high current density by decreasing the rate of exposure of the electronegative metal cathode to body fluids. A thinner polymer layer which erodes over a shorter period of time can compensate for a relatively low current density by increasing the rate of exposure of the electronegative metal cathode to body fluids. In some embodiments, the layer partially covers the endoprosthesis body. For example, the layer can cover at least about 10 percent (e.g., at least about 20 percent, at least about 30 percent, at least about 40 percent, at least about 50 percent, at least about 60 percent, at least about 70 percent, at least about 80 percent, at least about 90 percent, or at least about 95 percent) and/or at most 100 percent (e.g., at most about 95 percent, at most about 90 percent, at most about 80 percent, at most about 70 percent, at most about 60 percent, at most about 50 percent, at most about 40 percent, at most about 30 percent, or at most 20 percent) of the surface area of the endoprosthesis body.

Referring to FIG. 9, a method 200 of making an endoprosthesis 40 as described herein is shown. Method 200 includes forming a bioerodible tube, e.g. by cutting a tube (step 202), forming a pre-endoprosthesis from the bioerodible tube (step 204), applying a current-controlling layer, e.g. an oxide coating (step 206), forming an anode on the endoprosthesis tube (step 208), and/or applying a current-controlling polymer layer to the pre-endoprosthesis (step 210) to form an endoprosthesis. In some embodiments, one or more current-controlling layers are applied to the bioerodible tube, and the tube with the applied current-controlling layers is subsequently formed into an endoprosthesis.

The bioerodible tube can be formed (step 202) by manufacturing a tubular member capable of supporting a bodily lumen including (e.g., is formed of) one or more bioerodible electronegative metals. For example, a mass of bioerodible metal can be machined into a rod that is subsequently drilled to form the tubular member. As another example, a sheet of

bioerodible metal can be rolled to form a tubular member with overlapping portions, or opposing end portions of the rolled sheet can be joined (e.g., welded) together to form a tubular member. A bioerodible metal can also be extruded to form a tubular member. In certain embodiments, a bioerodible tube is made by thermal spraying, powder metallurgy, thixomolding, die casting, gravity casting, and/or forging.

As shown in FIG. 9, after the bioerodible tube is formed, the tube is formed into a pre-endoprosthesis (step 204). In some embodiments, selected portions of the tube are removed to form circular and connecting struts by laser cutting, as described in U.S. Patent No. 5,780,807, by Saunders, hereby incorporated by reference in its entirety. Other methods of removing portions of the tube can be used, such as mechanical machining (e.g., micro-machining, grit blasting or honing), electrical discharge machining (EDM), and photoetching (e.g., acid photoetching). The pre-endoprosthesis can be etched and/or electropolished to provide a selected finish. In certain embodiments, such as jelly-roll type endoprostheses, step 204 may be omitted.

In some embodiments, the current-controlling layer(s) such as an oxide, a hydride, and/or a fluoride layer is formed on the pre-endoprosthesis (step 206). Prior to applying the layer(s), selected surfaces (e.g., interior surface) or portions (e.g., portion between the end portions of the endoprosthesis) of the pre-endoprosthesis can be masked so that the current-controlling layer will not be applied to the masked surfaces or portions. General methods of forming coatings are described, for example, in Gray *et al.*, *Journal of Alloys and Compounds*, 336 (2002), 88-113. A current-controlling layer such as an oxide layer can be formed on the surface of the bioerodible tube by exposing the tube to air at ambient or elevated temperatures, for example, as described in You *et al.*, *Scripta mater*, 42 (2000), 1089-1094. In some embodiments, an oxide layer is deposited using plasma immersion ion implantation as described, for example, in Wan *et al.*, South Jiaotong University, Chengdu, 2005; and Gray *et al.*, *Journal of Alloys and Compounds*, 336 (2002), 88-113. Methods of forming oxide, hydride, and/or fluoride layers include vacuum arc deposition, as described for example, in Gust *et al.*, *Thin Solid Films*, 383 (2001), 224-226; and electrochemical ion reduction and plasma immersion ion implantation, as described, for example, in Bakkar *et al.*, *Corrosion Science*, 47 (2005), 1211-1225 and in U.S. Provisional Patent Application No.

60/862,318, filed October 20, 2006. The mask can be removed under ambient or inert atmosphere prior to proceeding to the subsequent step.

Referring to step 208, the anode is formed on a portion of the endoprosthesis. The anode layer can be deposited onto a portion of the endoprosthesis by pulsed laser deposition, for example, as described in Wang *et al.*, *Thin Solid films*, 471 (2005) 86-90. The anode can directly contact the cathode material in the endoprosthesis body at certain portions, for example, where the endoprosthesis was masked prior to current-controlling layer formation. In some embodiments, to obtain electrical contact between the anode layer and the cathode, a laser is used to form wells (e.g., wells 48) in the endoprosthesis under inert atmosphere, and the wells can be filled with the anode material by pulsed laser deposition such that at least a portion of the anode material directly contacts the cathode material. In some embodiments, the anode is in the form of metal cluster arrays. Arrays can be formed, for example, by electroless plating and lithographic methods.

As shown in step 210, in some embodiments, a current-controlling polymer layer is then applied to one or more portions of the endoprosthesis. The polymer layer can cover the junction at which the anode meets the endoprosthesis body to reduce galvanic corrosion at the junction. Depending on the polymer, one or more polymers can be dissolved in a solvent and applied to the pre-endoprosthesis. In some embodiments, for example, polymer layers are deposited by dip coating, electrostatic spraying, conventional air atomization spraying, and/or layer-by-layer deposition. In certain embodiments, patterns are generated in a polymer layer, e.g., by laser ablation, lithography, ink-jet printing, and/or screen printing. The polymer layer can have variable thicknesses along the length of the endoprosthesis. For example, the endoprosthesis can be dip-coated into a polymer solution at progressively decreasing depths to obtain a tapered polymer coating formed of many layers; the polymer can be coated to a uniform thickness and the variable thickness can be obtained by ablating sections of the polymer; the polymer can be coated using layer-by-layer deposition at select locations to obtain variable thicknesses. In some embodiments, an endoprosthesis has greater than one type of polymer layer located at the same or different locations on the endoprosthesis. For example, within a polymer layer, the thickness and composition of the polymers can be the same or different to provide desired erosion rates and erosion sequence. For example, the intermediate portion of an endoprosthesis can have a larger thickness of a slowly erodible

first polymer and the end portions of the endoprosthesis can contain a smaller thickness of a quickly erodible second polymer. The erosion directionality can allow for increased maintenance of patency for certain locations (e.g., weakened locations) in a body vessel. The polymer layers can be applied the same way or in different ways. For example, a first, innermost polymer layer can be spray-coated on the pre-endoprosthesis, and a second, outer polymer layer can include a polymer that is dip-coated onto the first layer.

Referring now to FIG. 10, an endoprosthesis having an increasing number of different polymer layers along its length can be produced from a metallic pre-endoprosthesis 240 by masking selective portions of the endoprosthesis. For example, during production, all portions of the pre-endoprosthesis can be coated 248 with a first polymer layer to generate a pre-endoprosthesis 250. Next, a portion of the pre-endoprosthesis is masked 252 (e.g., with a protective polymeric coating such as a styrene-isoprene-butadiene-styrene (SIBS) polymer), which protects the masked portion from further polymer layer coating, and the remaining section is coated 254 with a second polymer layer to make a pre-endoprosthesis 270. Finally, a second portion of the pre-endoprosthesis is masked 272, and the remaining portion is further coated 274 with a third polymer layer to make pre-endoprosthesis 290. The protective coatings can be removed, e.g., by rinsing 295 in a solvent in which only the masking polymer is soluble to afford endoprosthesis 300.

In some embodiments, the endoprosthesis has both exterior and interior surfaces coated with the polymer layer(s). In some embodiments, prior to applying the polymer layer(s), the interior surface or the exterior surface of the bioerodible tube is masked (e.g., by using a mandrel in the interior of the tube or a tight-fitting tube on the exterior of the tube) to apply the polymer layer(s) to only selected portion(s) of the tube.

In some embodiments, a medicament is incorporated into a polymer coating on an endoprosthesis. For example, a medicament can be adsorbed onto a polymer on an endoprosthesis. A medicament can be encapsulated in a bioerodible material and embedded in a polymer coating on an endoprosthesis. As another example, a medicament can be dissolved in a polymer solution and coated onto an endoprosthesis.

Referring to FIG. 11, in some embodiments, the pre-endoprosthesis is cut (step 230) to form the endoprosthesis after formation of the bioerodible tube (step 222), current-

controlling oxide coating (step 224), formation of the anode (step 226), and current-controlling polymer layer application (step 228).

Referring to FIG. 12, in some embodiments, a bioerodible tube is formed as previously described using a first material such as one or more relatively electronegative or electropositive metals. A counter-electrode is formed (step 314) in the bioerodible tube by making a gradient of a second material, such as one or more bioerodible metals, by plasma immersion ion implantation. Plasma immersion ion implantation is described, for example, in Wan *et al.*, South Jiaotong University, Chengdu, 2005; and Gray *et al.*, Journal of Alloys and Compounds, 336 (2002), 88-113. The first and second bioerodible materials form a galvanic couple. One or more current-controlling coatings (e.g., oxide, hydride, and/or fluoride layer) and/or one or more current-controlling polymer layers are then applied to the bioerodible tube (steps 316 and 318). Selected portions of the bioerodible tube can then be removed (step 320), for example, to afford struts in the final endoprosthesis. In some embodiments, removal of selected portions of the bioerodible tube occurs before or after formation of the counter-electrode gradient.

In use, the endoprostheses can be used, e.g., delivered and expanded, using a catheter delivery system, such as a balloon catheter system. Catheter systems are described in, for example, Wang U.S. 5,195,969, Hamlin U.S. 5,270,086, and Raeder-Devens, U.S. 6,726,712. Endoprosthesis and endoprosthesis delivery are also exemplified by the Radius® or Symbiot® systems, available from Boston Scientific Scimed, Maple Grove, MN.

The endoprostheses described herein can be of a desired shape and size (e.g., coronary stents, aortic stents, peripheral vascular stents, gastrointestinal stents, urology stents, and neurology stents). Depending on the application, the stent can have a diameter of between, for example, 1 mm to 46 mm. In certain embodiments, a coronary stent has an expanded diameter of from about 2 mm to about 6 mm. In some embodiments, a peripheral stent has an expanded diameter of from about 5 mm to about 24 mm. In certain embodiments, a gastrointestinal and/or urology stent has an expanded diameter of from about 6 mm to about 30 mm. In some embodiments, a neurology stent has an expanded diameter of from about 1 mm to about 12 mm. An abdominal aortic aneurysm (AAA) stent and a thoracic aortic aneurysm (TAA) stent can have a diameter from about 20 mm to about 46 mm.

While a number of embodiments have been described, the invention is not so limited.

In some embodiments, depending on the location of the anode and the cathode, the endoprosthesis is configured to erode sequentially from an interior cathode surface to an exterior anode surface, from an exterior cathode surface to an interior anode surface, from a center cathode portion to an exterior and an interior anode portions, or from an exterior and an interior cathode portion to a center anode portion. These constructions can allow the endoprosthesis to support the body vessel initially using the strength of multiple layers, and to reduce in thickness over time (e.g., after cells have endothelialized the endoprosthesis). The reduction in thickness can enhance the flexibility the endoprosthesis to better match the natural state of the body vessel.

The endoprostheses described herein can be a part of a stent, a covered stent or a stent-graft. For example, an endoprosthesis can include and/or be attached to a biocompatible, non-porous or semi-porous polymer matrix made of polytetrafluoroethylene (PTFE), expanded PTFE, polyethylene, urethane, or polypropylene.

The endoprostheses described herein can include non-metallic structural portions, e.g., polymeric portions. The polymeric portions can be erodible. The polymeric portions can be formed from a polymeric alloy. Polymeric stents have been described in U.S. Patent Application Serial No. 10/683,314, filed October 10, 2003; and U.S. Patent Application Serial No. 10/958,435, filed October 5, 2004, the entire contents of each of which is incorporated by herein reference.

The endoprostheses can include a releasable therapeutic agent, drug, or a pharmaceutically active compound, such as described in U.S. Patent No. 5,674,242, U.S. Patent Application Serial No. 09/895,415, filed July 2, 2001, U.S. Patent Application Serial No. 11/111,509, filed April 21, 2005, and U.S. Patent Application Serial No. 10/232,265, filed August 30, 2002. The therapeutic agents, drugs, or pharmaceutically active compounds can include, for example, anti-thrombogenic agents, antioxidants, anti-inflammatory agents, anesthetic agents, anti-coagulants, and antibiotics. The therapeutic agent, drug, or a pharmaceutically active compound can be dispersed in a polymeric coating carried by the endoprosthesis. The polymeric coating can include more than a single layer. For example, the coating can include two layers, three layers or more layers, e.g., five layers. The therapeutic agent can be a genetic therapeutic agent, a non-genetic therapeutic agent, or cells.

Therapeutic agents can be used singularly, or in combination. Therapeutic agents can be, for

example, nonionic, or they may be anionic and/or cationic in nature. An example of a therapeutic agent is one that inhibits restenosis, such as paclitaxel. The therapeutic agent can also be used, e.g., to treat and/or inhibit pain, encrustation of the endoprosthesis or sclerosing or necrosing of a treated lumen. Any of the above coatings and/or polymeric portions can be
5 dyed or rendered radio-opaque.

The endoprostheses described herein can be configured for non-vascular lumens. For example, it can be configured for use in the esophagus or the prostate. Other lumens include biliary lumens, hepatic lumens, pancreatic lumens, urethral lumens and ureteral lumens.

All references, such as patent applications, publications, and patents, referred to
10 herein are incorporated by reference in their entirety.

Other embodiments are within the claims.

WHAT IS CLAIMED IS:

1. A bioerodible endoprosthesis, comprising:
a relatively electronegative material and a relatively electropositive material between which a galvanic cell is formed, and
a current-controlling coating overlying at least a portion of the endoprosthesis effective to modulate the current or current density of the galvanic cell as the endoprosthesis degrades.
2. The endoprosthesis of claim 1, wherein the current-controlling coating controls exposure of at least one of the electronegative material and the electropositive material to body fluid.
3. The endoprosthesis of claim 2, wherein the current-controlling coating has a variable thickness, erosion rate, and/or porosity.
4. The endoprosthesis of claim 3, wherein the thickness of the current-controlling coating varies along the axis of the stent.
5. The endoprosthesis of claim 4, wherein the thickness of the current-controlling coating varies linearly.
6. The endoprosthesis of claim 4, wherein the thickness of the current-controlling coating varies non-linearly.
7. The endoprosthesis of claim 6, wherein the thickness of the current-controlling coating varies parabolically.
8. The endoprosthesis of claim 1, wherein the current density increases as a function of time.

9. The endoprosthesis of claim 1, wherein the current-controlling coating is a polymer, ceramic or metal.

10. The endoprosthesis of claim 1, wherein the endoprosthesis has a body comprising substantially electronegative material.

11. The endoprosthesis of claim 10, wherein the electropositive material is provided as a coating on the body.

12. The endoprosthesis of claim 1, wherein the endoprosthesis has a body including said electropositive material and said electronegative material, and the concentration of each of said electropositive material and said electronegative material varies along a length of the body.

13. The endoprosthesis of claim 1, wherein the endoprosthesis comprises a plurality of sections providing a different current or current density.

14. The endoprosthesis of claim 13, wherein the sections are along a length of the endoprosthesis.

15. The endoprosthesis of claim 14, wherein the sections are substantially sequentially exposed to body fluid over time.

16. An endoprosthesis, comprising:
a cathode region and an anode region between which a galvanic cell is formed when the endoprosthesis is implanted in the body, and
the anode region is degraded by galvanic corrosion such that current density generated by the galvanic cell is maintained between ± 10 percent during degradation of between about 5 percent to about 50 percent by weight of the anode region.

17. The endoprosthesis of claim 16, wherein the endoprosthesis undergoes both galvanic corrosion and bioerosion.

18. The endoprosthesis of claim 16, wherein both the cathode region and the anode region are bioerodible.

19. The endoprosthesis of claim 16, wherein the current density is sufficient for tumor treatment, restenosis inhibition or promotion of cell proliferation.

20. The endoprosthesis of claim 16, wherein the cathode region comprises magnesium or magnesium alloy.

21. The endoprosthesis of claim 20, wherein the magnesium alloy comprises materials selected from the group consisting of: zinc, aluminum, magnesium, lithium, iron, nickel, copper, and alloys thereof.

22. The endoprosthesis of claim 16, wherein the cathode region comprises materials selected from the group consisting of: iron, platinum, and gold.

23. The endoprosthesis of claim 16, further comprising a polymer coating.

24. The endoprosthesis of claim 16, further comprising a coating selected from the group consisting of: magnesium oxide, magnesium hydride, and magnesium fluoride.

25. The endoprosthesis of claim 16, wherein the endoprosthesis erodes from one end toward another end.

26. An erodible endoprosthesis, comprising:
a body including a relatively electronegative material and a relatively electropositive material between which a galvanic cell is formed, the concentration of electronegative and electropositive material varying along a length of the body.

27. The endoprosthesis of claim 26, wherein the body is formed of an alloy including the electronegative material and the electropositive material.

28. The endoprosthesis of claim 26, wherein the body includes a current-controlling layer.

FIG. 1A

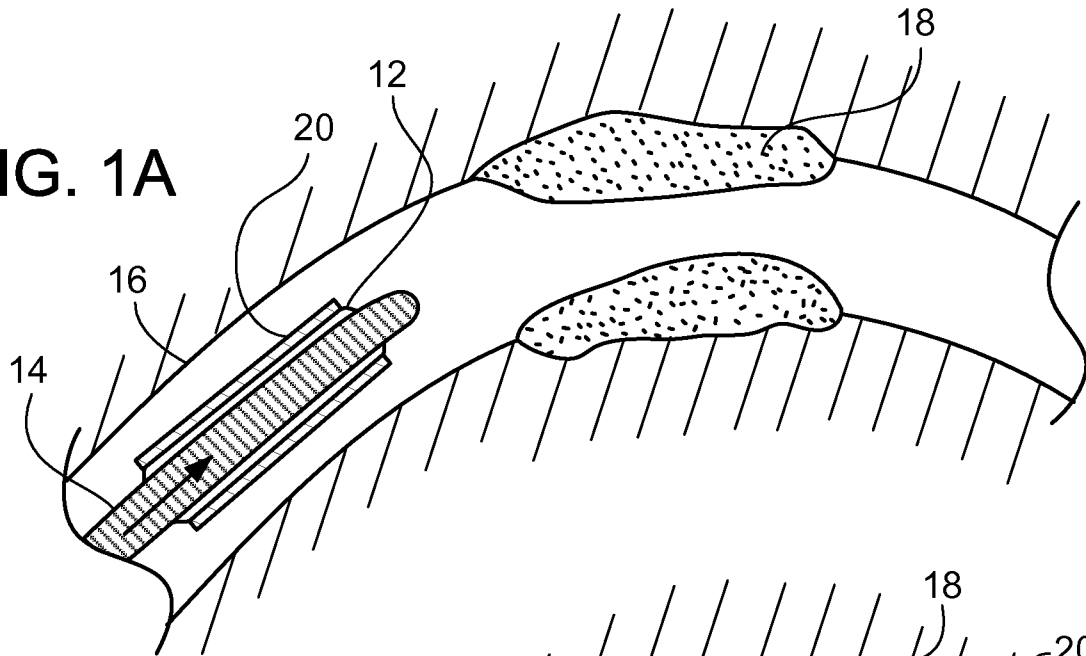

FIG. 1B

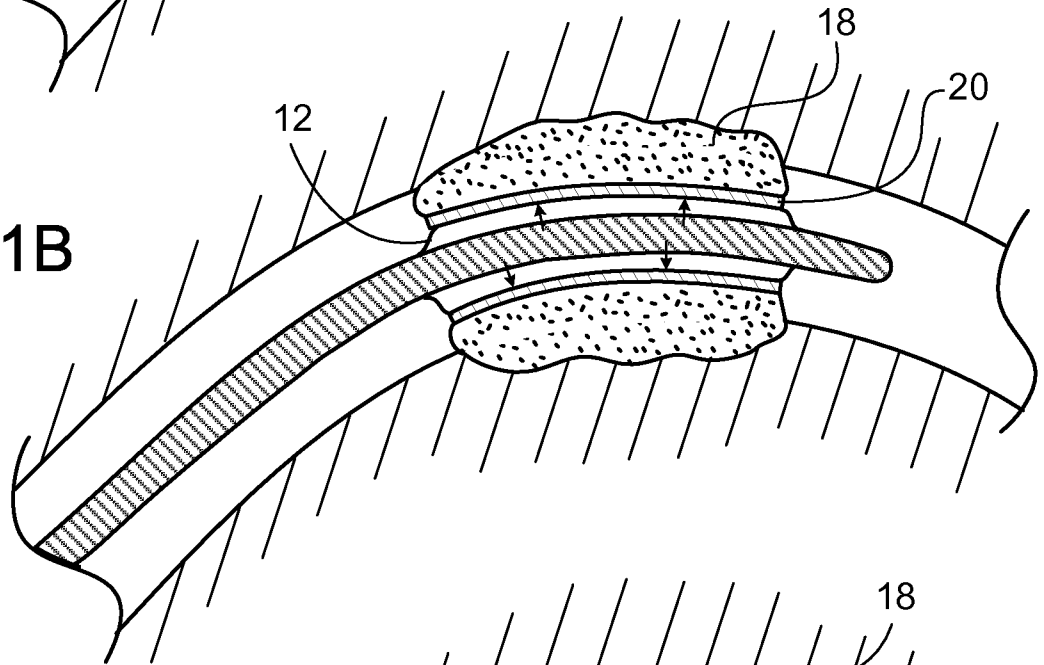
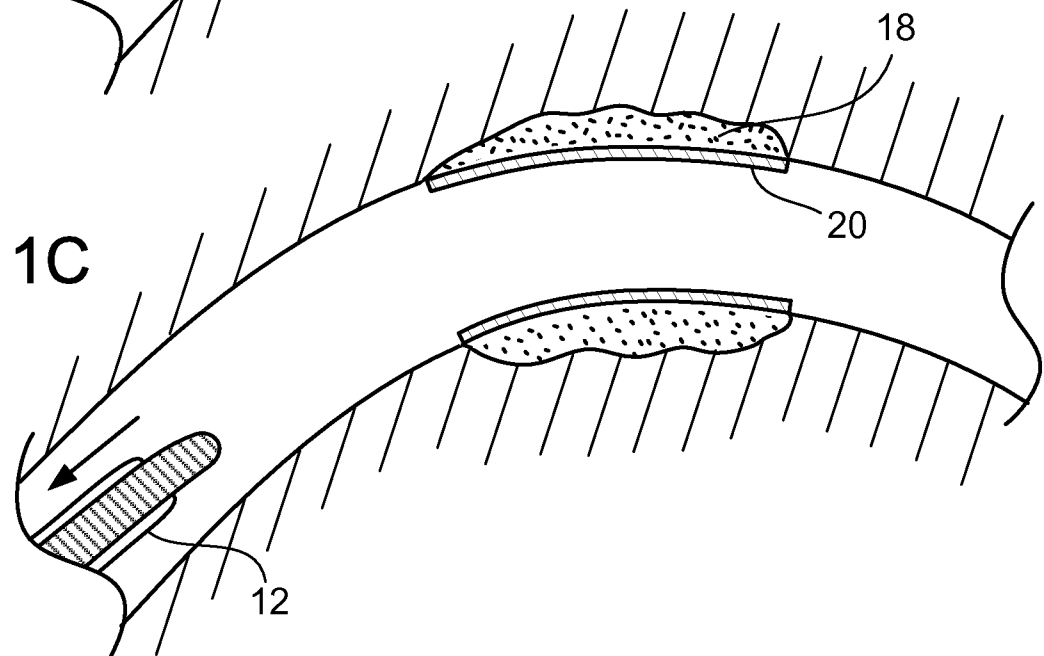

FIG. 1C



2/11

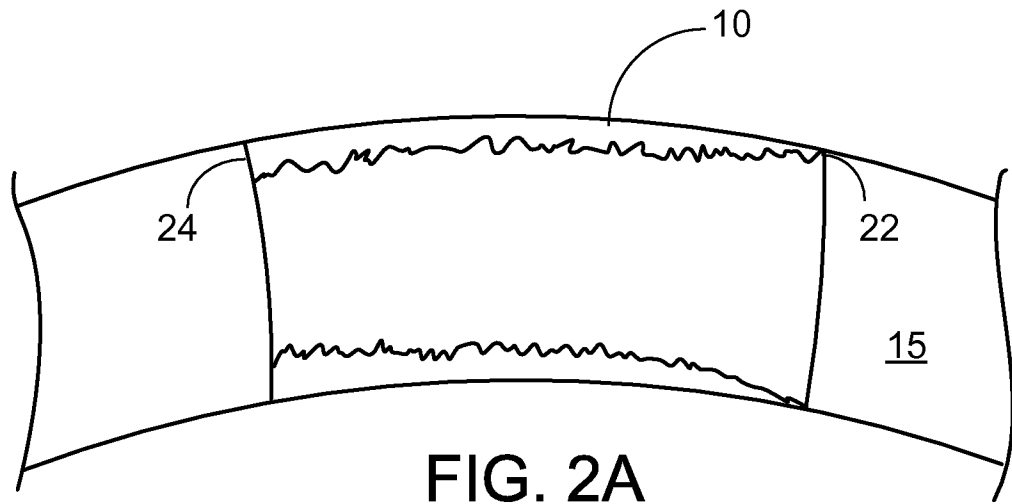

FIG. 2A

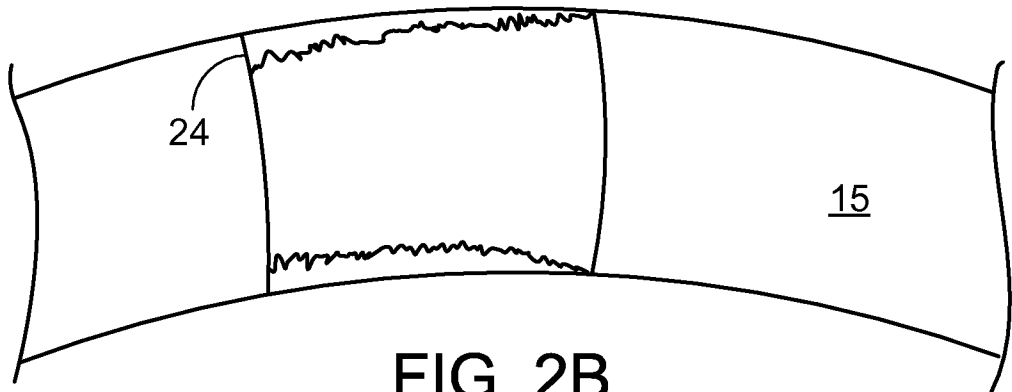

FIG. 2B

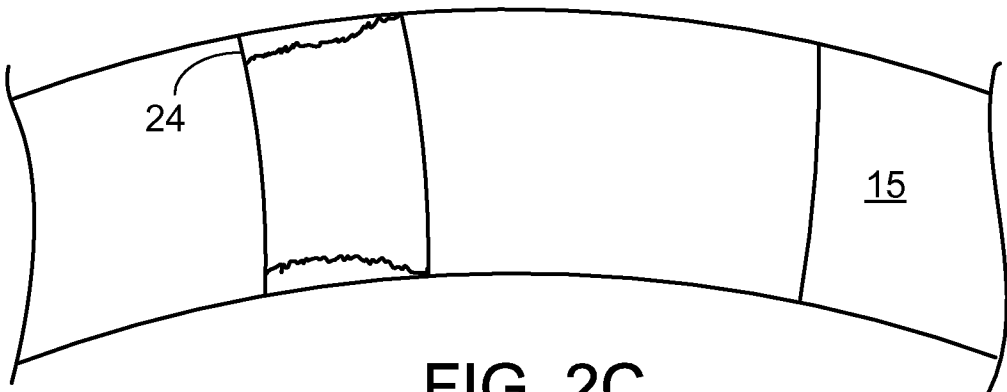

FIG. 2C

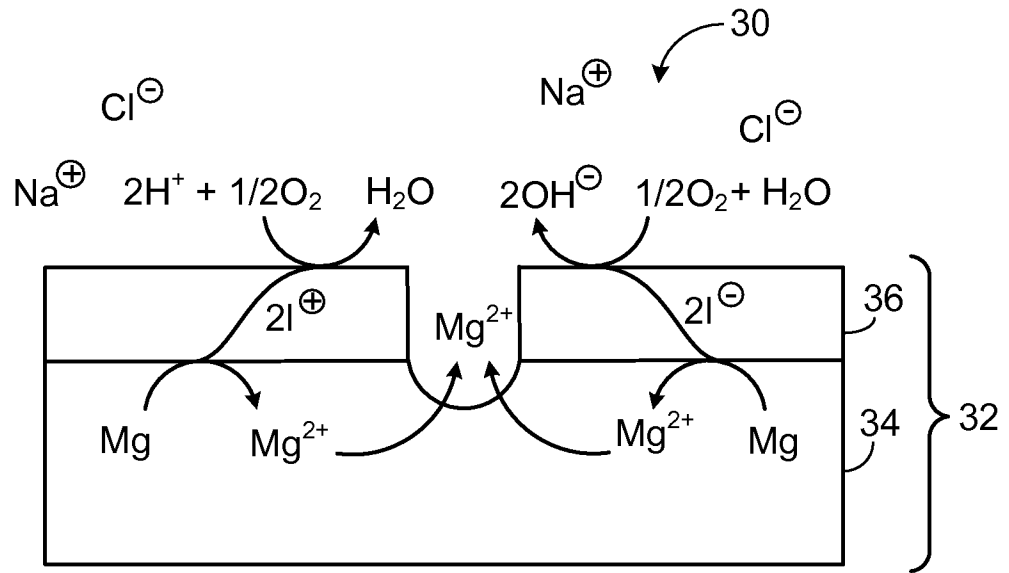

FIG. 3

4/11

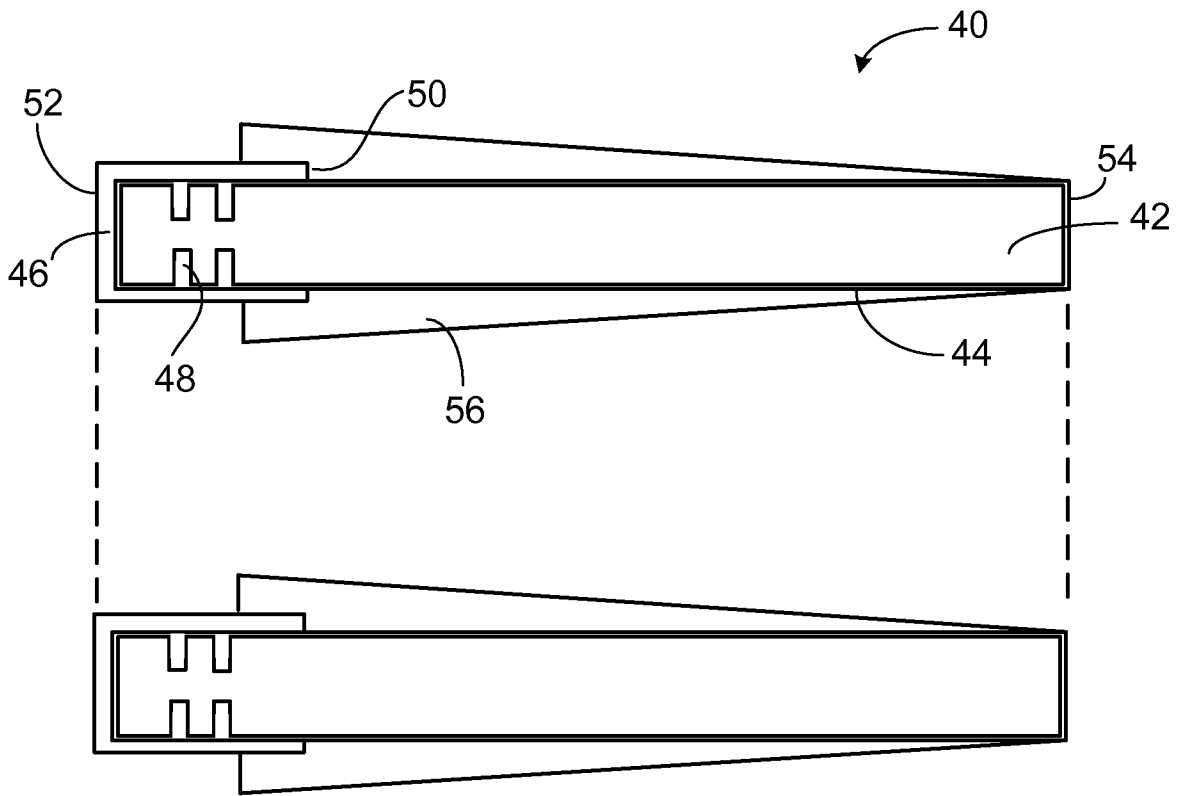

FIG. 4

5/11

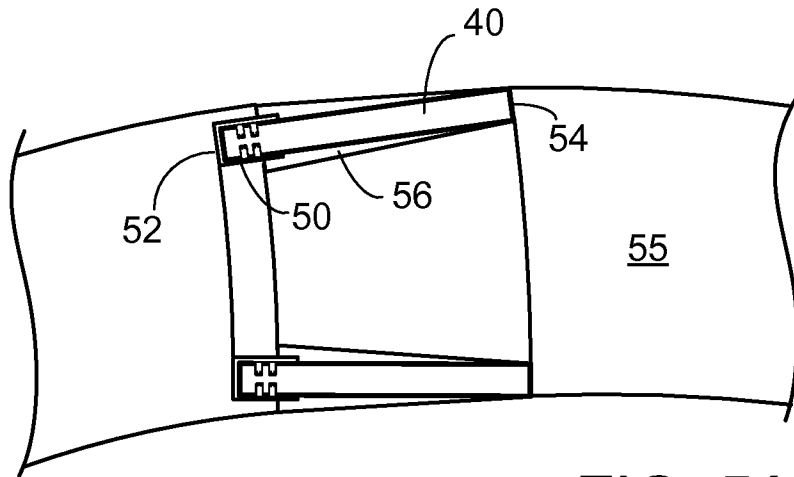

FIG. 5A

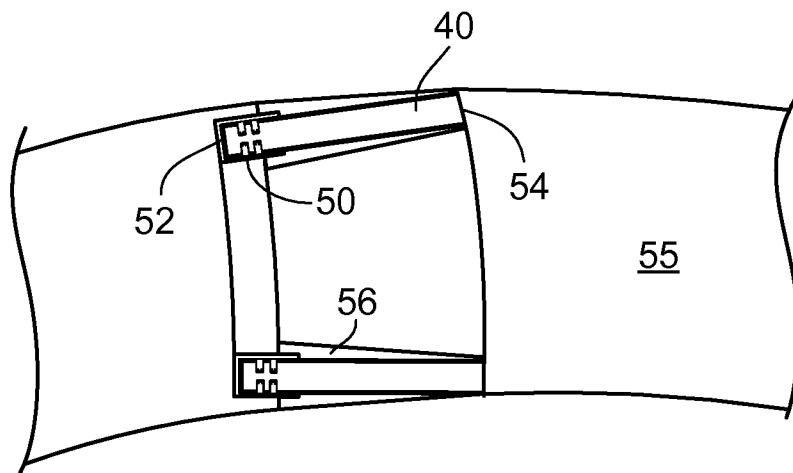

FIG. 5B

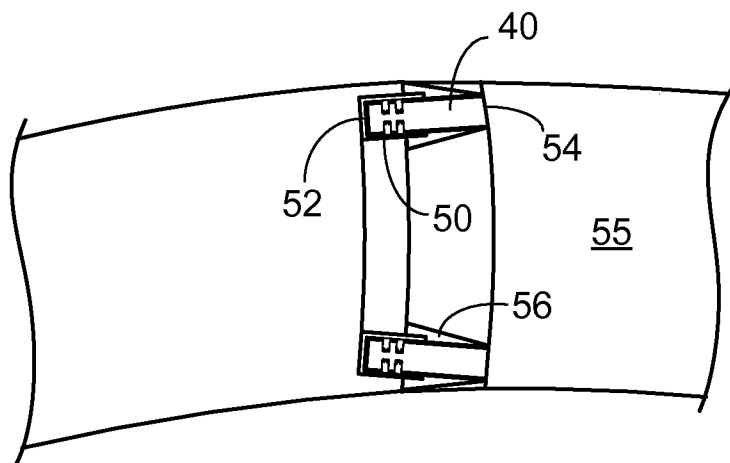

FIG. 5C

6/11

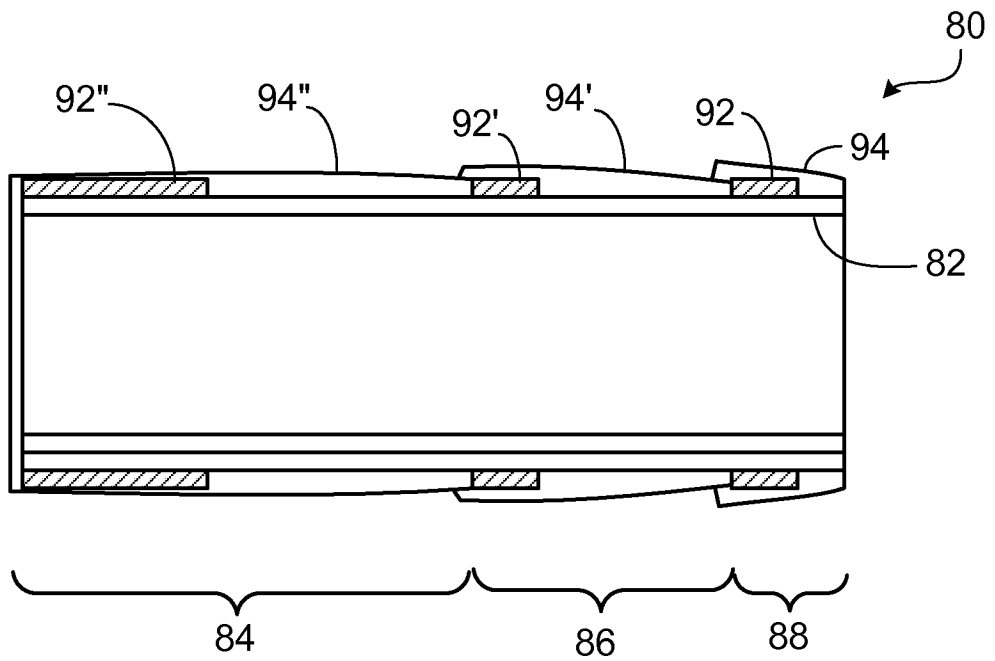

FIG. 6

7/11

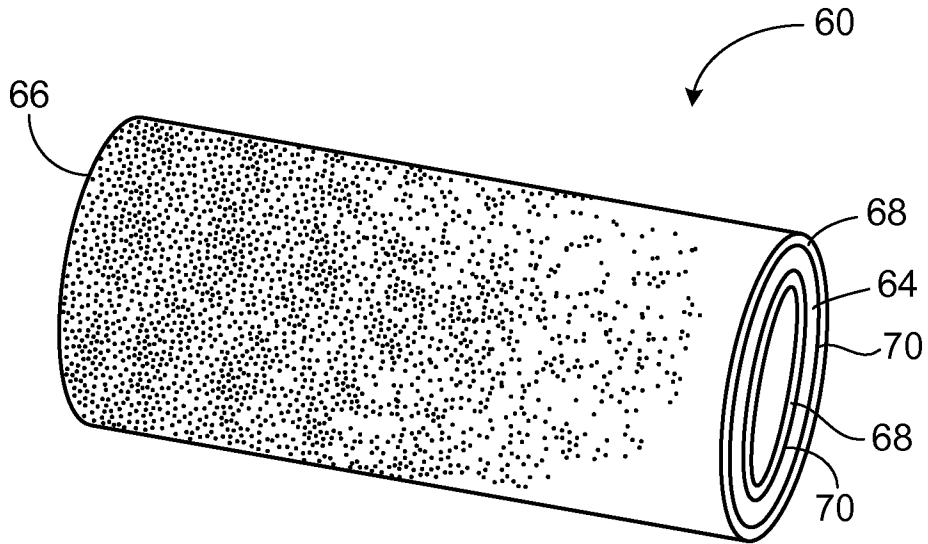

FIG. 7

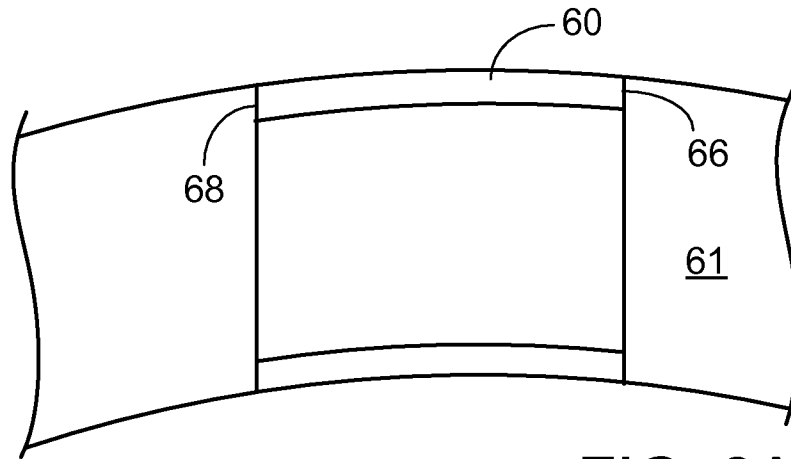

FIG. 8A

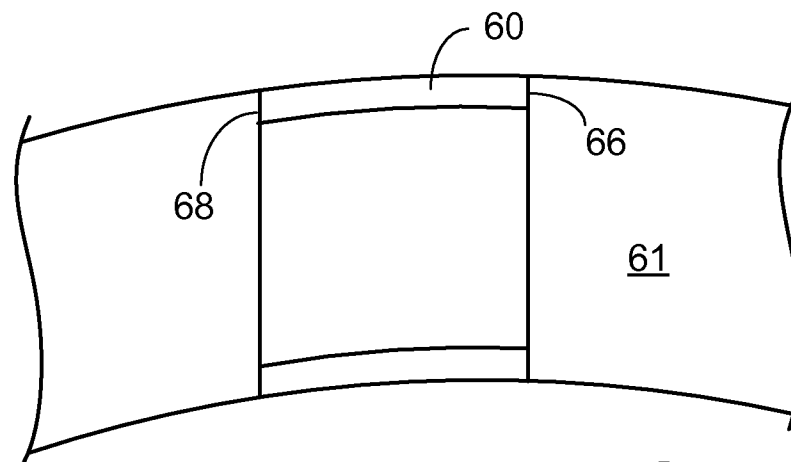

FIG. 8B

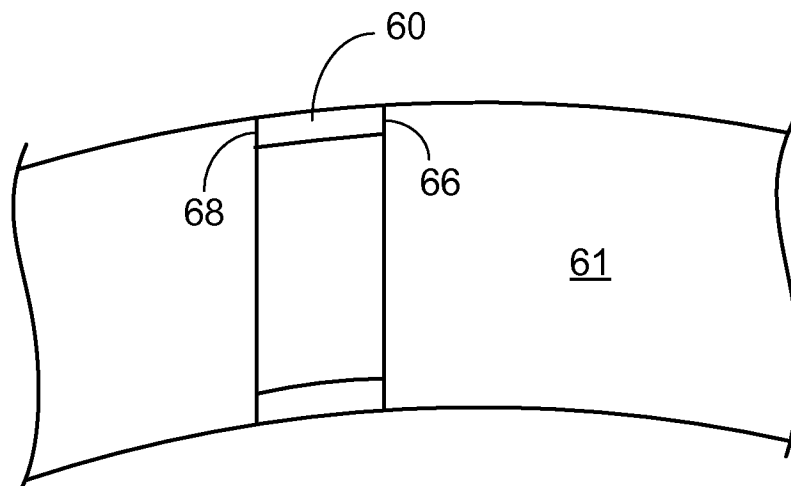

FIG. 8C

9/11

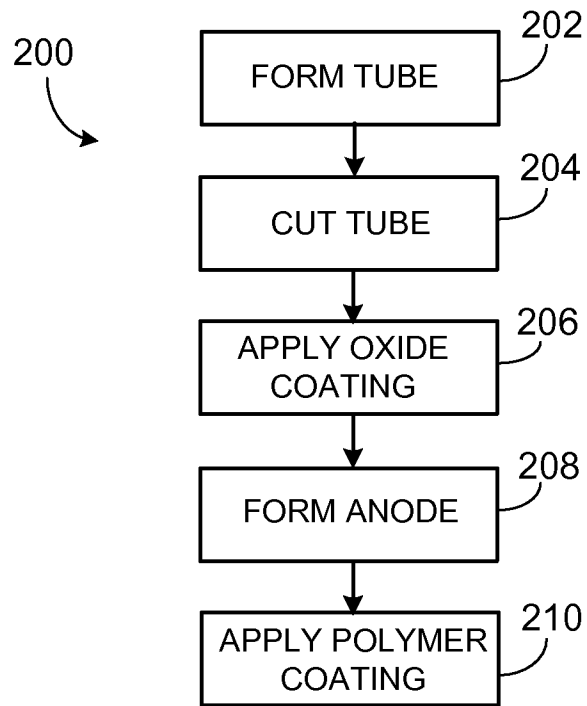

FIG. 9

10/11

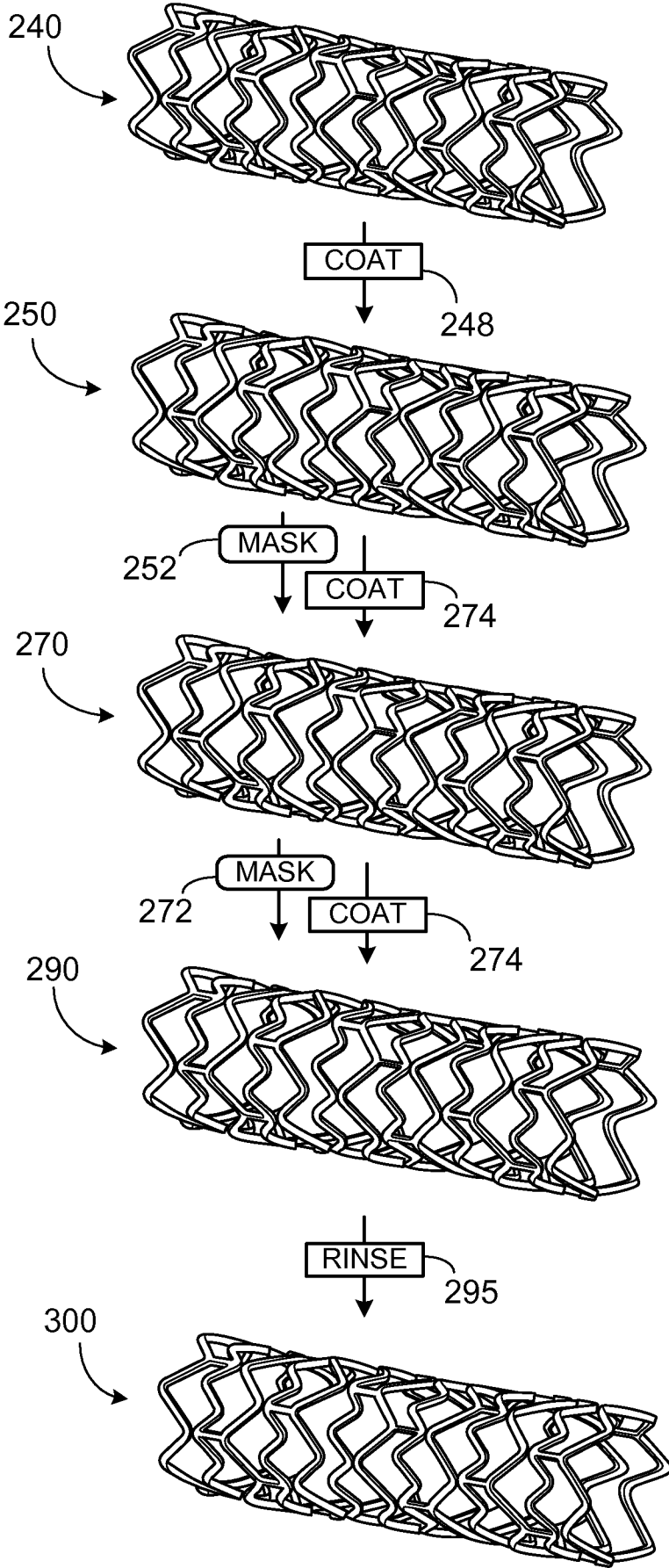

FIG. 10

