

(19) World Intellectual Property Organization  
International Bureau



(43) International Publication Date  
24 November 2011 (24.11.2011)

(10) International Publication Number  
**WO 2011/146752 A2**

- (51) **International Patent Classification:** Not classified
- (21) **International Application Number:** PCT/US2011/037213
- (22) **International Filing Date:** 19 May 2011 (19.05.2011)
- (25) **Filing Language:** English
- (26) **Publication Language:** English
- (30) **Priority Data:** 61/346,715 20 May 2010 (20.05.2010) US
- (71) **Applicant (for all designated States except US):** **BAKER HUGHES INCORPORATED** [US/US]; P.O. Box 4740, Houston, TX 77210-4740 (US).
- (72) **Inventor; and**
- (75) **Inventor/Applicant (for US only):** **STEVENS, John, H.** [US/DE]; An Der Wietze 18b, 30657 Hannover (DE).
- (74) **Agents:** **WELBORN, Brian, S.** et al.; Baker Hughes Incorporated, Intellectual Property Counsel, P.O. Box 4740, Houston, TX 77210-4740 (US).
- (81) **Designated States (unless otherwise indicated, for every kind of national protection available):** AE, AG, AL, AM, AO, AT, AU, AZ, BA, BB, BG, BH, BR, BW, BY, BZ,

CA, CH, CL, CN, CO, CR, CU, CZ, DE, DK, DM, DO, DZ, EC, EE, EG, ES, FI, GB, GD, GE, GH, GM, GT, HN, HR, HU, ID, IL, IN, IS, JP, KE, KG, KM, KN, KP, KR, KZ, LA, LC, LK, LR, LS, LT, LU, LY, MA, MD, ME, MG, MK, MN, MW, MX, MY, MZ, NA, NG, NI, NO, NZ, OM, PE, PG, PH, PL, PT, RO, RS, RU, SC, SD, SE, SG, SK, SL, SM, ST, SV, SY, TH, TJ, TM, TN, TR, TT, TZ, UA, UG, US, UZ, VC, VN, ZA, ZM, ZW.

(84) **Designated States (unless otherwise indicated, for every kind of regional protection available):** ARIPO (BW, GH, GM, KE, LR, LS, MW, MZ, NA, SD, SL, SZ, TZ, UG, ZM, ZW), Eurasian (AM, AZ, BY, KG, KZ, MD, RU, TJ, TM), European (AL, AT, BE, BG, CH, CY, CZ, DE, DK, EE, ES, FI, FR, GB, GR, HR, HU, IE, IS, IT, LT, LU, LV, MC, MK, MT, NL, NO, PL, PT, RO, RS, SE, SI, SK, SM, TR), OAPI (BF, BJ, CF, CG, CI, CM, GA, GN, GQ, GW, ML, MR, NE, SN, TD, TG).

**Declarations under Rule 4.17:**

— as to applicant's entitlement to apply for and be granted a patent (Rule 4.17(ii))

**Published:**

— without international search report and to be republished upon receipt of that report (Rule 48.2(g))

(54) **Title:** METHODS OF FORMING AT LEAST A PORTION OF EARTH-BORING TOOLS, AND ARTICLES FORMED BY SUCH METHODS

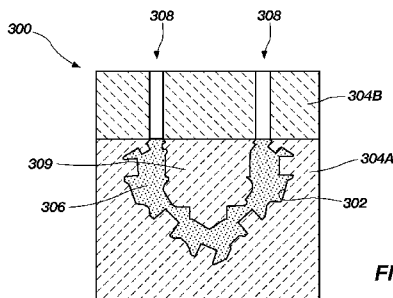

FIG. 4

(57) **Abstract:** Methods of forming at least a portion of an earth-boring tool include providing particulate matter comprising a hard material in a mold cavity, melting a metal and the hard material to form a molten composition comprising a eutectic or near-eutectic composition of the metal and the hard material, casting the molten composition to form the at least a portion of an earth-boring tool within the mold cavity, and providing an inoculant within the mold cavity. Methods of forming a roller cone of an earth-boring rotary drill bit comprise forming a molten composition, casting the molten composition within a mold cavity, solidifying the molten composition to form the roller cone, and controlling grain growth using an inoculant as the molten composition solidifies. Articles comprising components of earth-boring tools are fabricated using such methods.



WO 2011/146752 A2

- 1 -

**METHODS OF FORMING AT LEAST A PORTION OF EARTH-BORING TOOLS, AND ARTICLES FORMED BY SUCH METHODS****PRIORITY CLAIM**

5           This application claims the benefit of U.S. Provisional Patent Application Serial No. 61/346,715, filed May 20, 2010 and entitled "Methods of Controlling Microstructure in Casting of Earth-Boring Tools and Components of Such Tools, and Articles Formed by Such Methods."

          The subject matter of this application is related to the subject matter of  
10       co-pending U.S. Patent Application Serial No. 10/848,437, which was filed May 18, 2004 and entitled "Earth-Boring Bits," as well as to the subject matter of co-pending U.S. Patent Application Serial No. 11/116,752, which was filed April 28, 2005 and entitled "Earth-Boring Bits." The subject matter of this application is also related to the subject matter of U.S. Patent Application Serial No. \_\_\_\_\_, titled "Methods  
15       of Forming at Least a Portion of Earth-Boring Tools" (attorney docket number 1684-9995.1US) and U.S. Patent Application Serial No. \_\_\_\_\_, titled "Methods of Forming at Least a Portion of Earth-Boring Tools, and Articles Formed by Such Methods" (attorney docket number 1684-9997.1US), each filed on even date  
          herewith.

20

**TECHNICAL FIELD**

          Embodiments of the present disclosure relate to earth-boring tools, such as earth-boring rotary drill bits, to components of such tools, and to methods of manufacturing such earth-boring tools and components thereof.

25

**BACKGROUND**

          Earth-boring tools are commonly used for forming (*e.g.*, drilling and reaming) bore holes or wells (hereinafter "wellbores") in earth formations. Earth-boring tools include, for example, rotary drill bits, core bits, eccentric bits,  
30       bicenter bits, reamers, underreamers, and mills.

          Different types of earth-boring rotary drill bits are known in the art including, for example, fixed-cutter bits (which are often referred to in the art as "drag" bits), rolling-cutter bits (which are often referred to in the art as "rock" bits),

- 2 -

diamond-impregnated bits, and hybrid bits (which may include, for example, both fixed cutters and rolling cutters). The drill bit is rotated and advanced into the subterranean formation. As the drill bit rotates, the cutters or abrasive structures thereof cut, crush, shear, and/or abrade away the formation material to form the wellbore.

The drill bit is coupled, either directly or indirectly, to an end of what is referred to in the art as a "drill string," which comprises a series of elongated tubular segments connected end-to-end and extends into the wellbore from the surface of the formation. Often various tools and components, including the drill bit, may be coupled together at the distal end of the drill string at the bottom of the wellbore being drilled. This assembly of tools and components is referred to in the art as a "bottom hole assembly" (BHA).

The drill bit may be rotated within the wellbore by rotating the drill string from the surface of the formation, or the drill bit may be rotated by coupling the drill bit to a downhole motor, which is also coupled to the drill string and disposed proximate the bottom of the wellbore. The downhole motor may comprise, for example, a hydraulic Moineau-type motor having a shaft, to which the drill bit is mounted, that may be caused to rotate by pumping fluid (*e.g.*, drilling mud or fluid) from the surface of the formation down through the center of the drill string, through the hydraulic motor, out from nozzles in the drill bit, and back up to the surface of the formation through the annular space between the outer surface of the drill string and the exposed surface of the formation within the wellbore.

Rolling-cutter drill bits typically include three roller cones mounted on supporting bit legs that extend from a bit body, which may be formed from, for example, three bit head sections that are welded together to form the bit body. Each bit leg may depend from one bit head section. Each roller cone is configured to spin or rotate on a bearing shaft that extends from a bit leg in a radially inward and downward direction from the bit leg. The cones are typically formed from steel, but they also may be formed from a particle-matrix composite material (*e.g.*, a cermet composite such as cemented tungsten carbide). Cutting teeth for cutting rock and other earth formations may be machined or otherwise formed in or on the outer surfaces of each cone. Alternatively, receptacles are formed in outer surfaces of each cone, and inserts formed

- 3 -

of hard, wear resistant material are secured within the receptacles to form the cutting elements of the cones. As the rolling-cutter drill bit is rotated within a wellbore, the roller cones roll and slide across the surface of the formation, which causes the cutting elements to crush and scrape away the underlying formation.

5 Fixed-cutter drill bits typically include a plurality of cutting elements that are attached to a face of bit body. The bit body may include a plurality of wings or blades, which define fluid courses between the blades. The cutting elements may be secured to the bit body within pockets formed in outer surfaces of the blades. The cutting elements are attached to the bit body in a fixed manner, such that the cutting elements  
10 do not move relative to the bit body during drilling. The bit body may be formed from steel or a particle-matrix composite material (*e.g.*, cobalt-cemented tungsten carbide). In embodiments in which the bit body comprises a particle-matrix composite material, the bit body may be attached to a metal alloy (*e.g.*, steel) shank having a threaded end that may be used to attach the bit body and the shank to a drill string. As the  
15 fixed-cutter drill bit is rotated within a wellbore, the cutting elements scrape across the surface of the formation and shear away the underlying formation.

Impregnated diamond rotary drill bits may be used for drilling hard or abrasive rock formations such as sandstones. Typically, an impregnated diamond drill bit has a solid head or crown that is cast in a mold. The crown is attached to a steel shank that  
20 has a threaded end that may be used to attach the crown and steel shank to a drill string. The crown may have a variety of configurations and generally includes a cutting face comprising a plurality of cutting structures, which may comprise at least one of cutting segments, posts, and blades. The posts and blades may be integrally formed with the crown in the mold, or they may be separately formed and attached to the crown.  
25 Channels separate the posts and blades to allow drilling fluid to flow over the face of the bit.

Impregnated diamond bits may be formed such that the cutting face of the drill bit (including the posts and blades) comprises a particle-matrix composite material that includes diamond particles dispersed throughout a matrix material. The matrix  
30 material itself may comprise a particle-matrix composite material, such as particles of tungsten carbide, dispersed throughout a metal matrix material, such as a copper-based alloy.

- 4 -

It is known in the art to apply wear-resistant materials, such as “hardfacing” materials, to the formation-engaging surfaces of rotary drill bits to minimize wear of those surfaces of the drill bits cause by abrasion. For example, abrasion occurs at the formation-engaging surfaces of an earth-boring tool when those surfaces are engaged with and sliding relative to the surfaces of a subterranean formation in the presence of the solid particulate material (*e.g.*, formation cuttings and detritus) carried by conventional drilling fluid. For example, hardfacing may be applied to cutting teeth on the cones of roller cone bits, as well as to the gage surfaces of the cones. Hardfacing also may be applied to the exterior surfaces of the curved lower end or “shirttail” of each bit leg, and other exterior surfaces of the drill bit that are likely to engage a formation surface during drilling.

#### DISCLOSURE

In some embodiments, the invention includes a method of forming at least a portion of an earth-boring tool. The method comprises providing particulate matter comprising a hard material in a mold cavity, melting a metal and the hard material to form a molten composition comprising a eutectic or near-eutectic composition of the metal and the hard material, casting the molten composition to form the at least a portion of an earth-boring tool within the mold cavity, and providing an inoculant within the mold cavity.

In other embodiments, methods of forming a roller cone of an earth-boring rotary drill bit comprise forming a molten composition comprising a eutectic or near-eutectic composition of cobalt and tungsten carbide, casting the molten composition within a mold cavity, solidifying the molten composition within the mold cavity to form the roller cone, and controlling grain growth using an inoculant as the molten composition solidifies within the mold cavity.

In certain embodiments, the invention includes an article comprising at least a portion of an earth-boring tool. The article comprises a eutectic or near-eutectic composition including a metal phase, a hard material phase, and an inoculant.

30

- 5 -

## BRIEF DESCRIPTION OF THE DRAWINGS

While the specification concludes with claims particularly pointing out and distinctly claiming what are regarded as embodiments of the present invention, various features and advantages of this disclosure may be more readily ascertained from the following description of example embodiments provided with reference to the accompanying drawings, in which:

FIG. 1 is a side elevation view of an embodiment of a rolling-cutter drill bit that may include one or more components comprising a cast particle-matrix composite material including a eutectic or near-eutectic composition;

FIG. 2 is a partial sectional view of the drill bit of FIG. 1 and illustrates a rotatable cutter assembly that includes a roller cone;

FIG. 3 is a perspective view of an embodiment of a fixed-cutter drill bit that may include one or more components comprising a cast particle-matrix composite material including a eutectic or near-eutectic composition;

FIGS. 4 and 5 are used to illustrate embodiments of methods of the invention, and illustrate the casting of a roller cone like that shown in FIG. 2 within a mold; and

FIG. 6 is a schematic of a microstructure formed by embodiments of the invention.

## MODE(S) FOR CARRYING OUT THE INVENTION

The illustrations presented herein are not actual views of any particular earth-boring tool, drill bit, or component of such a tool or bit, but are merely idealized representations that are employed to describe embodiments of the present disclosure.

As used herein, the term earth-boring tool means and includes any tool used to remove formation material and form a bore (*e.g.*, a wellbore) through the formation by way of the removal of the formation material. Earth-boring tools include, for example, rotary drill bits (*e.g.*, fixed-cutter or “drag” bits and roller cone or “rock” bits), hybrid bits including both fixed cutters and roller elements, coring bits, percussion bits, bi-center bits, reamers (including expandable reamers and fixed-wing reamers), and other so-called “hole-opening” tools.

- 6 -

As used herein, the term “cutting element” means and includes any element of an earth-boring tool that is used to cut or otherwise disintegrate formation material when the earth-boring tool is used to form or enlarge a bore in the formation.

As used herein, the terms “cone” and “roller cone” mean and include any body comprising at least one formation-cutting structure that is mounted on a body of a rotary earth-boring tool, such as a rotary drill bit, in a rotatable manner, and that is configured to rotate relative to at least a portion of the body as the rotary earth-boring tool is rotated within a wellbore, and to remove formation material as the rotary earth-boring tool is rotated within a wellbore. Cones and roller cones may have a generally conical shape, but are not limited to structures having such a generally conical shape. Cones and roller cones may have shapes other than generally conical shapes.

In accordance with some embodiments of the present disclosure, earth-boring tools and/or components of earth-boring tools may comprise a cast particle-matrix composite material. The cast particle-matrix composite material may comprise a eutectic or near-eutectic composition. As used herein, the term “cast,” when used in relation to a material, means a material that is formed within a mold cavity, such that a body formed to comprise the cast material is formed to comprise a shape at least substantially similar to the mold cavity in which the material is formed. Accordingly, the terms “cast” and “casting” are not limited to conventional casting, wherein a molten material is poured into a mold cavity, but encompass melting material *in situ* in a mold cavity. In addition, as is explained in more detail below, casting processes may be conducted at elevated, greater than atmospheric, pressure. Casting may also be performed at atmospheric pressure or at less than atmospheric pressure. As used herein, the term “near-eutectic composition” means within about ten atomic percent (10 at%) or less of a eutectic composition. As a non-limiting example, the cast particle-matrix composite material may comprise a eutectic or near-eutectic composition of cobalt and tungsten carbide. Examples of embodiments of earth-boring tools and components of earth-boring tools that may include a cast particle-matrix composite material comprising a eutectic or near-eutectic composition are described below.

- 7 -

FIG. 1 illustrates an embodiment of an earth-boring tool of the present disclosure. The earth-boring tool of FIG. 1 is a rolling-cutter earth-boring rotary drill bit 100. The drill bit 100 includes a bit body 102 and a plurality of rotatable cutter assemblies 104. The bit body 102 may include a plurality of integrally formed bit legs 106, and threads 108 may be formed on the upper end of the bit body 102 for connection to a drill string. The bit body 102 may have nozzles 120 for discharging drilling fluid into a borehole, which may be returned along with cuttings up to the surface during a drilling operation. Each of the rotatable cutter assemblies 104 includes a roller cone 122 comprising a particle-matrix composite material and a plurality of cutting elements, such as cutting inserts 124 shown. Each roller cone 122 may include a conical gage surface 126 (FIG. 2). Additionally, each roller cone 122 may have a unique configuration of cutting inserts 124 or cutting elements, such that the roller cones 122 may rotate in close proximity to one another without mechanical interference.

FIG. 2 is a cross-sectional view illustrating one of the rotatable cutter assemblies 104 of the earth-boring drill bit 100 shown in FIG. 1. As shown, each bit leg 106 may include a bearing pin 128. The roller cone 122 may be supported by the bearing pin 128, and the roller cone 122 may be rotatable about the bearing pin 128. Each roller cone 122 may have a central cavity 130 that may be cylindrical and may form a journal bearing surface adjacent the bearing pin 128. The cavity 130 may have a flat thrust shoulder 132 for absorbing thrust imposed by the drill string on the roller cone 122. As illustrated in this example, the roller cone 122 may be retained on the bearing pin 128 by a plurality of locking balls 134 located in mating grooves formed in the surfaces of the cone cavity 130 and the bearing pin 128. Additionally, a seal assembly 136 may seal the bearing spaces between the cone cavity 130 and the bearing pin 128. The seal assembly 136 may be a metal face seal assembly, as shown, or may be a different type of seal assembly, such as an elastomer seal assembly.

Lubricant may be supplied to the bearing spaces between the cavity 130 and the bearing pin 128 by lubricant passages 138. The lubricant passages 138 may lead to a reservoir that includes a pressure compensator 140 (FIG. 1).

At least one of the roller cones 122 and the bit legs 106 of the earth-boring drill bit 100 of FIGS. 1 and 2 may comprise a cast particle-matrix composite material

- 8 -

comprising a eutectic or near-eutectic composition, and may be fabricated as discussed in further detail hereinbelow.

FIG. 3 is a perspective view of a fixed-cutter earth-boring rotary drill bit 200 that includes a bit body 202 that may be formed using embodiments of methods of the present disclosure. The bit body 202 may be secured to a shank 204 having a threaded connection portion 206 (*e.g.*, an American Petroleum Institute (API) threaded connection portion) for attaching the drill bit 200 to a drill string (not shown). In some embodiments, such as that shown in FIG. 3, the bit body 202 may be secured to the shank 204 using an extension 208. In other embodiments, the bit body 202 may be secured directly to the shank 204.

The bit body 202 may include internal fluid passageways (not shown) that extend between the face 203 of the bit body 202 and a longitudinal bore (not shown), which extends through the shank 204, the extension 208, and partially through the bit body 202. Nozzle inserts 214 also may be provided at the face 203 of the bit body 202 within the internal fluid passageways. The bit body 202 may further include a plurality of blades 216 that are separated by junk slots 218. In some embodiments, the bit body 202 may include gage wear plugs 222 and wear knots 228. A plurality of cutting elements 210 (which may include, for example, PDC cutting elements) may be mounted on the face 203 of the bit body 202 in cutting element pockets 212 that are located along each of the blades 216. The bit body 202 of the earth-boring rotary drill bit 200 shown in FIG. 3, or a portion of the bit body 202 (*e.g.*, the blades 216 or portions of the blades 216) may comprise a cast particle-matrix composite material comprising a eutectic or near-eutectic composition, and may be fabricated as discussed in further detail hereinbelow.

In accordance with some embodiments of the disclosure, earth-boring tools and/or components of earth-boring tools may be formed within a mold cavity using a casting process to cast a particle-matrix composite material comprising a eutectic or near-eutectic composition within the mold cavity. FIGS. 4 and 5 are used to illustrate the formation of a roller cone 122 like that shown in FIGS. 1 and 2 using such a casting process.

Referring to FIG. 4, a mold 300 may be provided that includes a mold cavity 302 therein. The mold cavity 302 may have a size and shape corresponding to

- 9 -

the size and shape of the roller cone 122 or other portion or component of an earth-boring tool to be cast therein. The mold 300 may comprise a material that is stable and will not degrade at temperatures to which the mold 300 will be subjected during the casting process. The material of the mold 300 also may be selected to

5 comprise a material that will not react with or otherwise detrimentally affect the material of the roller cone 122 to be cast within the mold cavity 302. As non-limiting examples, the mold 300 may comprise graphite or a ceramic material such as, for example, silicon oxide or aluminum oxide. After the casting process, it may be necessary to break or otherwise damage the mold 300 to remove the cast roller

10 cone 122 from the mold cavity 302. Thus, the material of the mold 300 also may be selected to comprise a material that is relatively easy to break or otherwise remove from around the roller cone 122 to enable the cast roller cone 122 (or other portion or component of an earth-boring tool) to be removed from the mold 300. As shown in FIG. 4, the mold may comprise two or more components, such as a base portion 304A

15 and a top portion 304B, that may be assembled together to form the mold 300. A bearing pin displacement member 309 may be used to define an interior void within the roller cone 122 to be cast within the mold 300 that is sized and configured to receive a bearing pin therein when the roller cone 122 is mounted on the bearing pin. In some embodiments, the bearing pin displacement member 309 may comprise a separate

20 body, as shown in FIG. 4. In other embodiments, the bearing pin displacement member 309 may be an integral part of the top portion 304B of the mold 300.

Particulate matter 306 comprising a hard material such as a carbide (*e.g.*, tungsten carbide), a nitride, a boride, *etc.*, optionally may be provided within the mold cavity 302. As used herein, the term “hard material” means and includes any material

25 having a Vickers Hardness of at least about 1200 (*i.e.*, at least about 1200HV30, as measured according to ASTM Standard E384 (Standard Test Method for Knoop and Vickers Hardness of Materials, ASTM Int’l, West Conshohocken, PA, 2010)).

After providing the particulate matter 306 within the mold cavity 302, a material comprising a eutectic or near-eutectic composition may be melted, and the

30 molten material may be poured into the mold cavity 302 and allowed to infiltrate the space between the particulate matter 306 within the mold cavity 302 until the mold cavity 302 is at least substantially full. The molten material may be poured into the

- 10 -

mold 300 through one or more openings 308 in the mold 300 that lead to the mold cavity 302.

In additional embodiments, no particulate matter 306 comprising hard material is provided within the mold cavity 302, and at least substantially the entire mold  
5 cavity 302 may be filled with the molten eutectic or near-eutectic composition to cast the roller cone 122 within the mold cavity 302.

In additional embodiments, particulate matter 306 comprising hard material is provided only at selected locations within the mold cavity 302 that correspond to regions of the roller cone 122 that are subjected to abrasive wear, such that those  
10 regions of the resulting roller cone 122 include a higher volume content of hard material compared to other regions of the roller cone 122 (formed from cast eutectic or near-eutectic composition without added particulate matter 306), which would have a lower volume content of hard material and exhibit a relatively higher toughness (*i.e.*, resistance to fracturing).

In additional embodiments, the particulate matter 306 comprises both particles  
15 of hard material and particles of material or materials that will form a molten eutectic or near-eutectic composition upon heating the particulate matter 306 to a sufficient temperature to melt the material or materials that will form the molten eutectic or near-eutectic composition. In such embodiments, the particulate matter 306 is  
20 provided within the mold cavity 302. The mold cavity 302 may be vibrated to settle the particulate matter 306 to remove voids therein. The particulate matter 306 may be heated to a temperature sufficient to form the molten eutectic or near-eutectic composition. Upon formation of the molten eutectic or near-eutectic composition, the molten material may infiltrate the space between remaining solid particles in the  
25 particulate matter 306, which may result in settling of the particulate matter 306 and a decrease in occupied volume. Thus, excess particulate matter 306 also may be provided over the mold cavity 302 (*e.g.*, within the openings 308 in the mold) to account for such settling that may occur during the casting process.

In accordance with some embodiments of the present disclosure, one or more  
30 inoculants may be provided within the mold cavity 302 to assist in controlling the nature of the resultant microstructure of the roller cone 122 to be cast within the mold cavity 302. As used herein, the term “inoculant” means and includes any substance

that will control the growth of grains of at least one material phase upon cooling a eutectic or near-eutectic composition in a casting process. For example, inoculants may aid in limiting grain growth. For example, addition of an inoculant to the eutectic or near-eutectic composition can be used to refine the microstructure of the cast material (at least at the surface thereof) and improve the strength and/or wear characteristics of the surface of the cast material. By way of example and not limitation, such an inoculant may promote nucleation of grains. Such nucleation may cause adjacent grains to be closer together, thus limiting the amount of grain growth before adjacent grains interact. The final microstructure of a eutectic or near-eutectic composition comprising an inoculant may therefore be finer than a similar eutectic or near-eutectic composition without the inoculant. Inoculants may include, for example, cobalt aluminate, cobalt metasilicate, cobalt oxide, or a combination of such materials. Thus, the resulting microstructure may include grains having a characteristic dimension that is reduced relative to the characteristic dimension of the grains that would form in the absence of such an inoculant. Characteristic dimensions may depend on, for example, concentration of inoculants, temperature of the melt, thermal gradient, *etc.* For example, FIG. 6 shows a schematic of a microstructure formed with an inoculant. The microstructure may comprise a metal phase 602 (shown as white regions in FIG. 6) and a hard material phase 604 (shown as black regions in FIG. 6). The metal phase 602 and/or the hard material phase 604 may comprise the inoculant. The metal phase 602 and/or the hard material phase 604 may have various characteristic dimensions, and the characteristic dimensions of the metal phase 602 and/or the hard material phase 604 may vary within a single eutectic or near-eutectic composition.

By way of example, the inoculant or inoculants may comprise from about 0.5% to about 5% by weight of the eutectic or near-eutectic composition.

In embodiments in which the material comprising a eutectic or near-eutectic composition is melted in a separate crucible and subsequently poured into the mold cavity 302 in the molten state, the inoculant may be added to the crucible with the molten eutectic or near-eutectic composition prior to pouring the resultant mixture into the mold cavity 302. The inoculant may be added to the molten eutectic or near-eutectic composition just prior to the casting process in an effort to maintain the potency of the inoculant. In additional embodiments, the inoculants may be provided

in a separate tundish or other container, and the molten material comprising the eutectic or near-eutectic composition may be poured into the tundish, where the inoculants may mix with the eutectic or near-eutectic composition. The resulting molten mixture then may be poured from the intermediate tundish into the mold cavity 302. In yet further  
5    embodiments, the inoculants may be provided on a surface of the mold 300 within the mold cavity 302 prior to casting the eutectic or near-eutectic composition within the mold cavity 302.

          In embodiments in which the particulate matter 306 comprises both particles of  
10    hard material and particles of material or materials that will form a molten eutectic or near-eutectic composition upon heating the particulate matter 306 to a sufficient temperature to melt the material or materials that will form the molten eutectic or near-eutectic composition, the inoculant may be mixed with the particulate matter 306 prior to providing the particulate matter 306 within the mold cavity, the inoculant may be applied to interior surfaces of the mold 300 within the mold cavity 302, or the  
15    inoculant may be added to the particulate matter 306 within the mold cavity 302 after providing the particulate matter 306 within the mold cavity 302 (either prior to heating the particulate matter 306 to a sufficient temperature to melt the material or materials that will form the molten eutectic or near-eutectic composition, or after melting the material or materials that will form the molten eutectic or near-eutectic composition  
20    within the mold cavity 302).

          After casting the roller cone 122 within the mold cavity 302, the roller cone 122 may be removed from the mold 300. As previously mentioned, it may be necessary to break the mold 300 apart in order to remove the roller cone 122 from the mold 300.

          The eutectic or near-eutectic composition may comprise a eutectic or  
25    near-eutectic composition of a metal and a hard material.

          The metal of the eutectic or near-eutectic composition may comprise a commercially pure metal such as cobalt, iron, or nickel. In additional embodiments, the metal of the eutectic or near-eutectic composition may comprise an alloy based on one or more of cobalt, iron, and nickel. In such alloys, one or more elements may be  
30    included to tailor selected properties of the composition, such as strength, toughness, corrosion resistance, or electromagnetic properties.

The hard material of the eutectic or near-eutectic composition may comprise a ceramic compound, such as a carbide, a boride, an oxide, a nitride, or a mixture of one or more such ceramic compounds.

In some non-limiting examples, the metal of the eutectic or near-eutectic  
5 composition may comprise a cobalt-based alloy, and the hard material may comprise tungsten carbide. For example, the eutectic or near-eutectic composition may comprise from about 40% to about 90% cobalt or cobalt-based alloy by weight, from about 0.5 percent to about 3.8 percent by weight carbon, and the balance may be tungsten. In a further example, the eutectic or near-eutectic composition may comprise from about  
10 55% to about 85% cobalt or cobalt-based alloy by weight, from about 0.85 percent to about 3.0 percent carbon by weight, and the balance may be tungsten. Even more particularly, the eutectic or near-eutectic composition may comprise from about 65% to about 78% cobalt or cobalt-based alloy by weight, from about 1.3 percent to about 2.35 percent carbon by weight, and the balance may be tungsten. For example, the eutectic  
15 or near-eutectic composition may comprise about 69% cobalt or cobalt-based alloy by weight (about 78.8 atomic percent cobalt), about 1.9% carbon by weight (about 10.6 atomic percent carbon), and about 29.1% tungsten by weight (about 10.6 atomic percent tungsten). As another example, the eutectic or near-eutectic composition may comprise about 75% cobalt or cobalt-based alloy by weight, about 1.53% carbon by  
20 weight, and about 23.47% tungsten by weight.

Once the eutectic or near-eutectic composition is heated to the molten state, the metal and hard material phases will not be distinguishable in the molten composition, which will simply comprise a generally homogenous molten solution of the various elements. Upon cooling the molten composition, however, phase segregation will  
25 occur and the metal phase and hard material phase may segregate from one another and solidify to form a composite microstructure that includes regions of the metal phase and regions of the hard material phase. Furthermore, in embodiments in which particulate matter 306 is provided within the mold 300 prior to casting the eutectic or near-eutectic composition in the mold cavity 302, additional phase regions resulting  
30 from the particulate matter 306 may also be present in the final microstructure of the resulting cast roller cone 122.

- 14 -

As the molten eutectic or near-eutectic composition is cooled and phase segregation occurs, metal and hard material phases may be formed again. Hard material phases may include metal carbide phases. For example, such metal carbide phases may be of the general formula  $M_6C$  and  $M_{12}C$ , wherein M represents one or more metal elements and C represents carbon. As a particular example, in 5 embodiments wherein a desirable hard material phase to be formed is monotungsten carbide (WC), the eta phases of the general formula  $W_xCo_yC$ , wherein x is from about 0.5 to about 6 and y is from about 0.5 to about 6 (e.g.,  $W_3Co_3C$  and  $W_6Co_6C$ ) also may be formed. Such metal carbide eta phases tend to be relatively wear-resistant, but also 10 more brittle compared to the primary carbide phase (e.g., WC). Thus, such metal carbide eta phases may be undesirable for some applications. In accordance with some embodiments of the disclosure, a carbon correction cycle may be used to adjust the stoichiometry of the resulting metal carbide phases in such a manner as to reduce (e.g., at least substantially eliminate) the resulting amount of such undesirable metal carbide 15 eta phases (e.g.,  $M_6C$  and  $M_{12}C$ ) in the cast roller cone 122 and increase the resulting amount of a desirable primary metal carbide phase (e.g., MC and/or  $M_2C$ ) in the cast roller cone 122. By way of example and not limitation, a carbon correction cycle as disclosed in U.S. Patent No. 4,579,713, which issued April 1, 1986 to Lueth, may be used to adjust the stoichiometry of the resulting metal carbide phases in the cast roller 20 cone 122.

Briefly, the roller cone 122 (or the mold 300 with the materials to be used to form the roller cone 122 therein) may be provided in a vacuum furnace together with a carbon-containing substance, and then heated to a temperature within the range extending from about 800°C to about 1100°C, while maintaining the furnace under 25 vacuum. A mixture of hydrogen and methane then may be introduced into the furnace. The percentage of methane in the mixture may be from about 10% to about 90% of the quantity of methane needed to obtain equilibrium of the following equation at the selected temperature and pressure within the furnace:

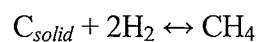

30 Following the introduction of the hydrogen and methane mixture into the furnace chamber, the furnace chamber is maintained within the selected temperature and pressure range for a time period sufficient for the following reaction:

- 15 -

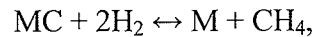

where M may be selected from the group of W, Ti, Ta, Hf and Mo, to substantially reach equilibrium, but in which the reaction:

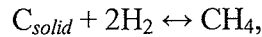

5 does not reach equilibrium either due to the total hold time or due to gas residence time but, rather, the methane remains within about 10% and about 90% of the amount needed to obtain equilibrium. This time period may be from about 15 minutes to about 5 hours, depending upon the selected temperature. For example, the time period may be approximately 90 minutes at a temperature of about 1000°C and a pressure of about  
10 one atmosphere.

The carbon correction cycle may be performed on the materials to be used to form the cast roller cone 122 prior to, or during the casting process in such a manner as to hinder or prevent the formation of the undesirable metal carbide eta phases (*e.g.*,  $M_6C$  and  $M_{12}C$ ) in the cast roller cone 122. In additional embodiments, it may be  
15 possible to perform the carbon correction cycle after the casting process in such a manner as to convert undesirable metal carbide phases previously formed in the roller cone 122 during the casting process to more desirable metal carbide phases (*e.g.*,  $MC$  and/or  $M_2C$ ), although such conversion may be limited to regions at or proximate the surface of the roller cone 122.

20 In additional embodiments, an annealing process may be used to adjust the stoichiometry of the resulting metal carbide phases in such a manner as to reduce (*e.g.*, at least substantially eliminate) the resulting amount of such undesirable metal carbide phases (*e.g.*,  $M_6C$  and  $M_{12}C$ ) in the cast roller cone 122 and increase the resulting amount of a desirable primary metal carbide phase (*e.g.*,  $MC$  and/or  $M_2C$ ) in the cast  
25 roller cone 122. For example, the cast roller cone 122 may be heated in a furnace to a temperature of at least about 1200°C (*e.g.*, about 1225°C) for at least about three hours (*e.g.*, about 6 hours or more). The furnace may comprise a vacuum furnace, and a vacuum may be maintained within the furnace during the annealing process. For example, a pressure of about 0.015 millibar may be maintained within the vacuum  
30 furnace during the annealing process. In additional embodiments, the furnace may be maintained at about atmospheric pressure, or it may be pressurized, as discussed in further detail below. In such embodiments, the atmosphere within the furnace may

comprise an inert atmosphere. For example, the atmosphere may comprise nitrogen or a noble gas.

During the processes described above for adjusting the stoichiometry of metal carbide phases within the roller cone 122, free carbon (*e.g.*, graphite) that is present in or adjacent the roller cone 122 also may be absorbed and combined with metal (*e.g.*, tungsten) to form a metal carbide phase (*e.g.*, tungsten carbide), or combined into existing metal carbide phases.

In some embodiments, a hot isostatic pressing (HIP) process may be used to improve the density and decrease porosity in the cast roller cone 122. For example, during the casting process, an inert gas may be used to pressurize a chamber in which the casting process may be conducted. The pressure may be applied during the casting process, or after the casting process but prior to removing the cast roller cone 122 from the mold 300. In additional embodiments, the cast roller cone 122 may be subjected to a HIP process after removing the cast roller cone 122 from the mold 300. By way of example, the cast roller cone 122 may be heated to a temperature of from about 300°C to about 1200°C while applying an isostatic pressure to exterior surfaces of the roller cone 122 of from about 7.0 MPa to about 310,000 MPa (about 1 ksi to about 45,000 ksi). Furthermore, a carbon correction cycle as discussed hereinabove may be incorporated into the HIP process such that the carbon correction cycle is performed either immediately before or after the HIP process in the same furnace chamber used for the HIP process.

In additional embodiments, a cold isostatic pressing process may be used to improve the density and decrease porosity in the cast roller cone 122. In other words, the cast roller cone 122 may be subjected to isostatic pressures of at least about 10,000 MPa while maintaining the roller cone 122 at a temperature of about 300°C or less.

After forming the roller cone 122, the roller cone 122 may be subjected to one or more surface treatments. For example, a peening process (*e.g.*, a shot peening process, a rod peening process, or a hammer peening process) may be used to impart compressive residual stresses within the surface regions of the roller cone 122. Such residual stresses may improve the mechanical strength of the surface regions of the roller cone 122, and may serve to hinder cracking in the roller cone 122 during use in drilling that might result from, for example, fatigue.

Casting of articles can enable the formation of articles having relatively complex geometric configurations that may not be attainable by other fabrication methods. Thus, by casting earth-boring tools and/or components of earth-boring tools as disclosed herein, earth-boring tools and/or components of earth-boring tools may be formed that have designs that are relatively more geometrically complex compared to previously fabricated earth-boring tools and/or components of earth-boring tools.

Additional non-limiting example embodiments of the disclosure are described below.

Embodiment 1: A method of forming at least a portion of an earth-boring tool, comprising providing particulate matter comprising a hard material in a mold cavity, melting a metal and the hard material to form a molten composition comprising a eutectic or near-eutectic composition of the metal and the hard material, casting the molten composition to form the at least a portion of an earth-boring tool within the mold cavity, and providing an inoculant within the mold cavity.

Embodiment 2: The method of Embodiment 1, further comprising adjusting a stoichiometry of at least one hard material phase of the at least a portion of the earth-boring tool.

Embodiment 3: The method of Embodiment 2, wherein adjusting a stoichiometry of at least one hard material phase of the at least a portion of the earth-boring tool comprises converting at least one of an  $M_6C$  phase and an  $M_{12}C$  phase to at least one of an  $MC$  phase and an  $M_2C$  phase, wherein  $M$  is at least one metal element and  $C$  is carbon.

Embodiment 4: The method of Embodiment 3, wherein converting at least one of an  $M_6C$  phase and an  $M_{12}C$  phase to at least one of an  $MC$  phase and an  $M_2C$  phase comprises converting  $W_xCo_yC$  to  $WC$ , wherein  $x$  is from about 0.5 to about 6 and  $y$  is from about 0.5 to about 6.

Embodiment 5: The method of any of Embodiments 1 through 4, wherein melting a metal and a hard material to form a molten composition comprises melting a mixture comprising from about 40% to about 90% cobalt or cobalt-based alloy by weight and from about 0.5% to about 3.8% carbon by weight, wherein a balance of the mixture is at least substantially comprised of tungsten.

Embodiment 6: The method of any of Embodiments 1 through 5, wherein melting a metal and a hard material to form a molten composition comprises melting a mixture comprising from about 55% to about 85% cobalt or cobalt-based alloy by weight and from about 0.85% to about 3.0% carbon by weight, wherein a balance of  
5 the mixture is at least substantially comprised of tungsten.

Embodiment 7: The method of any of Embodiments 1 through 6, wherein melting a metal and a hard material to form a molten composition comprises melting a mixture comprising from about 65% to about 78% cobalt or cobalt-based alloy by weight and from about 1.3% to about 2.35% carbon by weight, wherein a balance of  
10 the mixture is at least substantially comprised of tungsten.

Embodiment 8: The method of any of Embodiments 1 through 7, wherein melting a metal and a hard material to form a molten composition comprises melting a mixture comprising about 69% cobalt or cobalt-based alloy by weight, about 1.9% carbon by weight, and about 29.1% tungsten by weight.

Embodiment 9: The method of any of Embodiments 1 through 7, wherein melting a metal and a hard material to form a molten composition comprises melting about 75% cobalt or cobalt-based alloy by weight, about 1.53% carbon by weight, and about 23.47% tungsten by weight.  
15

Embodiment 10: The method of any of Embodiments 1 through 9, further comprising pressing the at least a portion of the earth-boring tool after casting the molten composition to form the at least a portion of the earth-boring tool within the mold cavity.  
20

Embodiment 11: The method of any of Embodiments 1 through 10, further comprising treating at least a surface region of the at least a portion of the earth-boring tool to provide residual compressive stresses within the at least a surface region of the  
25 at least a portion of the earth-boring tool.

Embodiment 12: The method of Embodiment 11, wherein treating at least the surface region of the at least a portion of the earth-boring tool comprises subjecting the at least the surface region of the at least a portion of the earth-boring tool to a peening  
30 process.

Embodiment 13: The method of any of Embodiments 1 through 12, wherein providing the inoculant comprises providing at least one of a transition metal aluminate, a transition metal metasilicate, and a transition metal oxide.

5 Embodiment 14: The method of any of Embodiments 1 through 13, wherein providing the inoculant comprises providing at least one of cobalt aluminate, cobalt metasilicate, and cobalt oxide.

Embodiment 15: The method of any of Embodiments 1 through 14, wherein melting a metal and a hard material to form a molten composition comprises forming a eutectic or near-eutectic composition of cobalt and tungsten carbide.

10 Embodiment 16: The method of any of Embodiments 1 through 15, wherein providing the inoculant comprises controlling grain growth as the molten composition solidifies.

Embodiment 17: A method of forming a roller cone of an earth-boring rotary drill bit, comprising forming a molten composition comprising a eutectic or  
15 near-eutectic composition of cobalt and tungsten carbide, casting the molten composition within a mold cavity, solidifying the molten composition within the mold cavity to form the roller cone, and controlling grain growth using an inoculant as the molten composition solidifies within the mold cavity.

Embodiment 18: The method of Embodiment 17, further comprising  
20 converting at least one of a  $W_3Co_3C$  phase region and a  $W_6Co_6C$  phase region within the roller cone to at least one of WC and  $W_2C$ .

Embodiment 19: The method of Embodiment 17 or Embodiment 18, wherein forming a molten composition comprises forming a molten composition comprising about 69% cobalt or cobalt-based alloy by weight, about 1.9% carbon by weight, and  
25 about 29.1% tungsten by weight.

Embodiment 20: The method of any of Embodiments 17 through 19, further comprising pressing the roller cone after casting the molten composition within the mold cavity.

Embodiment 21: The method of any of Embodiments 17 through 20, further  
30 comprising treating at least a surface region of the roller cone to provide residual compressive stresses within the at least a surface region of the roller cone.

- 20 -

Embodiment 22: The method of Embodiment 21, wherein treating at least a surface region of the roller cone comprises subjecting the at least the surface region of the roller cone to a peening process.

Embodiment 23: The method of any of Embodiments 17 through 22, wherein  
5 controlling grain growth comprises adding at least one of a transition metal aluminate, a transition metal metasilicate, and a transition metal oxide to the mold cavity.

Embodiment 24: The method of any of Embodiments 17 through 23, wherein controlling grain growth comprises adding at least one of cobalt aluminate, cobalt metasilicate, and cobalt oxide to the mold cavity.

10 Embodiment 25: An article comprising at least a portion of an earth-boring tool, the article comprising a eutectic or near-eutectic composition including a metal phase, a hard material phase, and an inoculant.

Embodiment 26: The article of Embodiment 25, wherein the inoculant comprises at least one of a transition metal aluminate, a transition metal metasilicate,  
15 and a transition metal oxide.

Embodiment 27: The article of Embodiment 25 or Embodiment 26, wherein the eutectic or near-eutectic composition comprises from about 0.5% to about 5% inoculant by weight.

Embodiment 28: The article of any of Embodiments 25 through 27, wherein  
20 the metal phase comprises at least one of cobalt, iron, nickel, and alloys thereof.

Embodiment 29: The article of any of Embodiments 25 through 28, wherein the hard material phase comprises a ceramic compound selected from the group consisting of carbides, borides, oxides, nitride, and mixtures thereof.

Embodiment 30: The article of any of Embodiments 25 through 29, further  
25 comprising a composite microstructure that includes regions of the metal phase and regions of the hard material phase.

Embodiment 31: The article of any of Embodiments 25 through 30, wherein the hard material phase comprises a metal carbide phase including at least one of an MC phase and an M<sub>2</sub>C phase, wherein M is at least one metal element and C is carbon.

30 Embodiment 32: A partially formed article comprising a generally homogenous molten solution disposed within a mold, the solution comprising a metal, a hard material, and an inoculant.

Embodiment 33: The partially formed article of Embodiment 32, wherein the inoculant comprises at least one of a transition metal aluminate, a transition metal metasilicate, and a transition metal oxide.

Embodiment 34: The partially formed article of Embodiment 32 or  
5 Embodiment 33, wherein the inoculant comprises at least one of cobalt aluminate, cobalt metasilicate, and cobalt oxide.

Embodiment 35: The partially formed article of any of Embodiments 32 through 34, wherein the metal comprises cobalt or a cobalt-based alloy, and the hard material comprises tungsten carbide.

10 Embodiment 36: A partially formed article comprising at least a portion of an earth-boring tool. The partially formed article comprises a eutectic or near-eutectic composition comprising a metal and a hard material, at least one mixed metal carbide phase comprising at least one of an  $M_6C$  phase and an  $M_{12}C$  phase, and an inoculant. M is at least one metal element, and C is carbon.

15 Embodiment 37: The partially formed article of Embodiment 36, wherein the at least one mixed metal carbide phase comprises an eta phase of  $W_xCo_yC$ . X is from about 0.5 to about 6, and y is from about 0.5 to about 6.

Embodiment 38: The partially formed article of Embodiment 36 or  
20 Embodiment 37, wherein the eutectic or near-eutectic composition comprises from about 40% to about 90% cobalt or cobalt-based alloy by weight and from about 0.5% to about 3.8% carbon by weight, and wherein a balance of the mixture is at least substantially comprised of tungsten.

Embodiment 39: The partially formed article of any of Embodiments 36 through 38, wherein the inoculant comprises a material selected from the group  
25 consisting of transition metal aluminates, transition metal metasilicates, and transition metal oxides.

Embodiment 40: The partially formed article of any of Embodiments 36 through 39, wherein the inoculant comprises a material selected from the group consisting of cobalt aluminate, cobalt metasilicate, and cobalt oxide.

30 Although the foregoing description contains many specifics, these are not to be construed as limiting the scope of the present invention, but merely as providing certain exemplary embodiments. Similarly, other embodiments of the invention may be

- 22 -

devised that do not depart from the scope of the present invention. For example, features described herein with reference to one embodiment also may be provided in others of the embodiments described herein. The scope of the invention is, therefore, indicated and limited only by the appended claims and their legal equivalents, rather than by the foregoing description. All additions, deletions, and modifications to the invention, as disclosed herein, which fall within the meaning and scope of the claims, are encompassed by the present invention.

## CLAIMS

What is claimed is:

- 5           1.       A method of forming at least a portion of an earth-boring tool,  
comprising:  
providing particulate matter comprising a hard material in a mold cavity;  
melting a metal and the hard material to form a molten composition comprising a  
eutectic or near-eutectic composition of the metal and the hard material;  
10       casting the molten composition to form the at least a portion of an earth-boring tool  
within the mold cavity; and  
providing an inoculant within the mold cavity.
2.       The method of claim 1, further comprising adjusting a stoichiometry of  
15       at least one hard material phase of the at least a portion of the earth-boring tool.
3.       The method of claim 2, wherein adjusting a stoichiometry of at least  
one hard material phase of the at least a portion of the earth-boring tool comprises  
converting at least one of an  $M_6C$  phase and an  $M_{12}C$  phase to at least one of an MC  
20       phase and an  $M_2C$  phase, wherein M is at least one metal element and C is carbon.
4.       The method of claim 3, wherein converting at least one of an  $M_6C$   
phase and an  $M_{12}C$  phase to at least one of an MC phase and an  $M_2C$  phase comprises  
converting  $W_xCo_yC$  to WC, wherein x is from about 0.5 to about 6 and y is from about  
25       0.5 to about 6.
5.       The method of any of claims 1 through 4, wherein melting a metal and  
a hard material to form a molten composition comprises melting a mixture comprising  
from about 40% to about 90% cobalt or cobalt-based alloy by weight and from about  
30       0.5% to about 3.8% carbon by weight, wherein a balance of the mixture is at least  
substantially comprised of tungsten.

- 24 -

6. The method of any of claims 1 through 5, wherein melting a metal and a hard material to form a molten composition comprises melting a mixture comprising from about 55% to about 85% cobalt or cobalt-based alloy by weight and from about 0.85% to about 3.0% carbon by weight, wherein a balance of the mixture is at least  
5 substantially comprised of tungsten.

7. The method of any of claims 1 through 6, wherein melting a metal and a hard material to form a molten composition comprises melting a mixture comprising from about 65% to about 78% cobalt or cobalt-based alloy by weight and from about  
10 1.3% to about 2.35% carbon by weight, wherein a balance of the mixture is at least substantially comprised of tungsten.

8. The method of any of claims 1 through 7, wherein melting a metal and a hard material to form a molten composition comprises melting a mixture comprising  
15 about 69% cobalt or cobalt-based alloy by weight, about 1.9% carbon by weight, and about 29.1% tungsten by weight.

9. The method of any of claims 1 through 7, wherein melting a metal and a hard material to form a molten composition comprises melting about 75% cobalt or  
20 cobalt-based alloy by weight, about 1.53% carbon by weight, and about 23.47% tungsten by weight.

10. The method of any of claims 1 through 9, wherein providing the inoculant comprises providing at least one of a transition metal aluminate, a transition  
25 metal metasilicate, and a transition metal oxide.

11. The method of any of claims 1 through 10, wherein providing the inoculant comprises providing at least one of cobalt aluminate, cobalt metasilicate, and cobalt oxide.

30

- 25 -

12. The method of any of claims 1 through 11, wherein melting a metal and a hard material to form a molten composition comprises forming a eutectic or near-eutectic composition of cobalt and tungsten carbide.

5 13. An article comprising at least a portion of an earth-boring tool, the article comprising a eutectic or near-eutectic composition including a metal phase, a hard material phase, and an inoculant.

10 14. The article of claim 13, wherein the inoculant comprises at least one of a transition metal aluminate, a transition metal metasilicate, and a transition metal oxide.

15 15. The article of claim 13 or claim 14, wherein the eutectic or near-eutectic composition comprises from about 0.5% to about 5% inoculant by weight.

16. The article of any of claims 13 through 15, wherein the metal phase comprises at least one of cobalt, iron, nickel, and alloys thereof.

20 17. The article of any of claims 13 through 16, wherein the hard material phase comprises a ceramic compound selected from the group consisting of carbides, borides, oxides, nitride, and mixtures thereof.

25 18. The article of any of claims 13 through 17, further comprising a composite microstructure that includes regions of the metal phase and regions of the hard material phase.

30 19. The article of any of claims 13 through 18, wherein the hard material phase comprises a metal carbide phase including at least one of an MC phase and an  $M_2C$  phase, wherein M is at least one metal element and C is carbon.

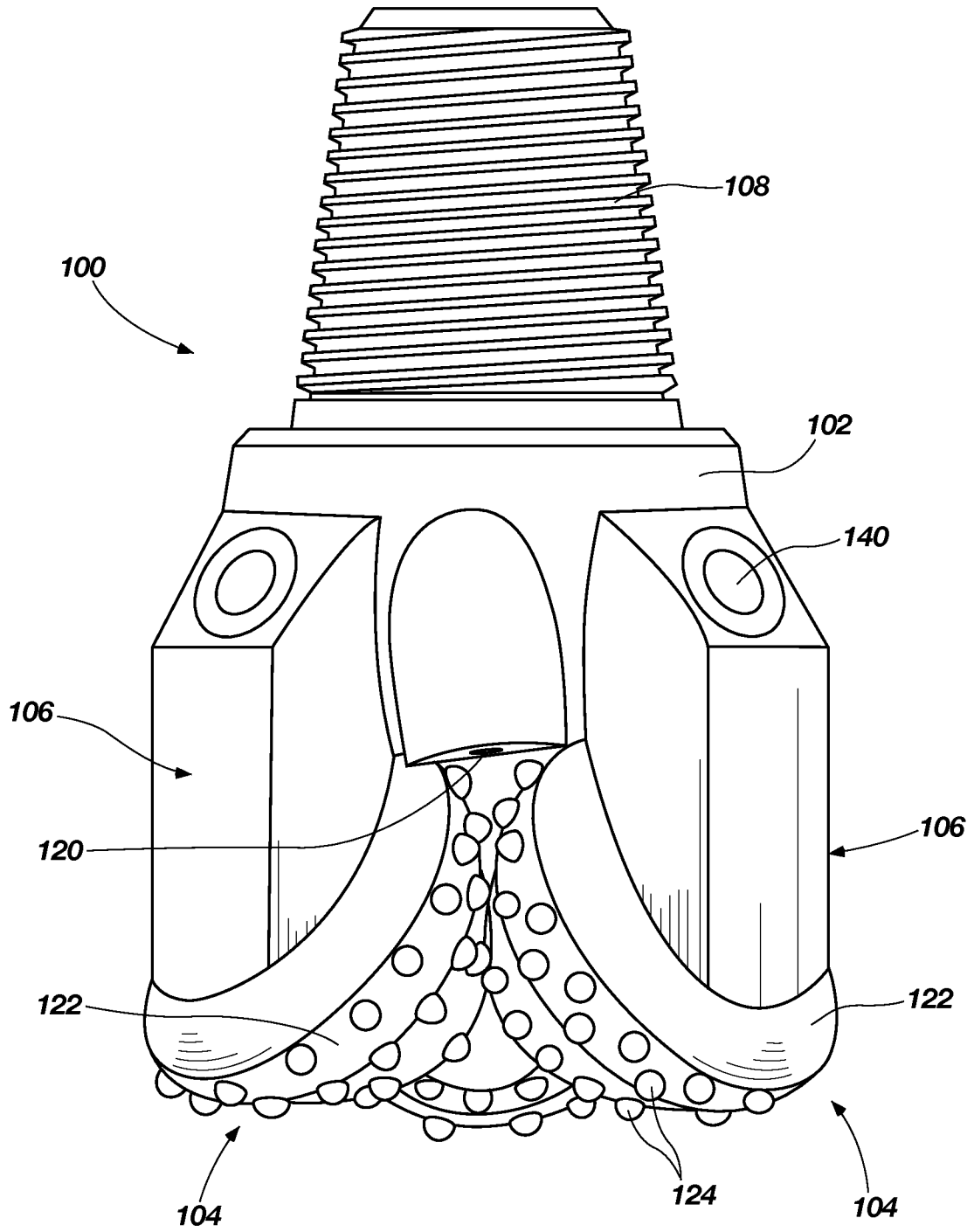
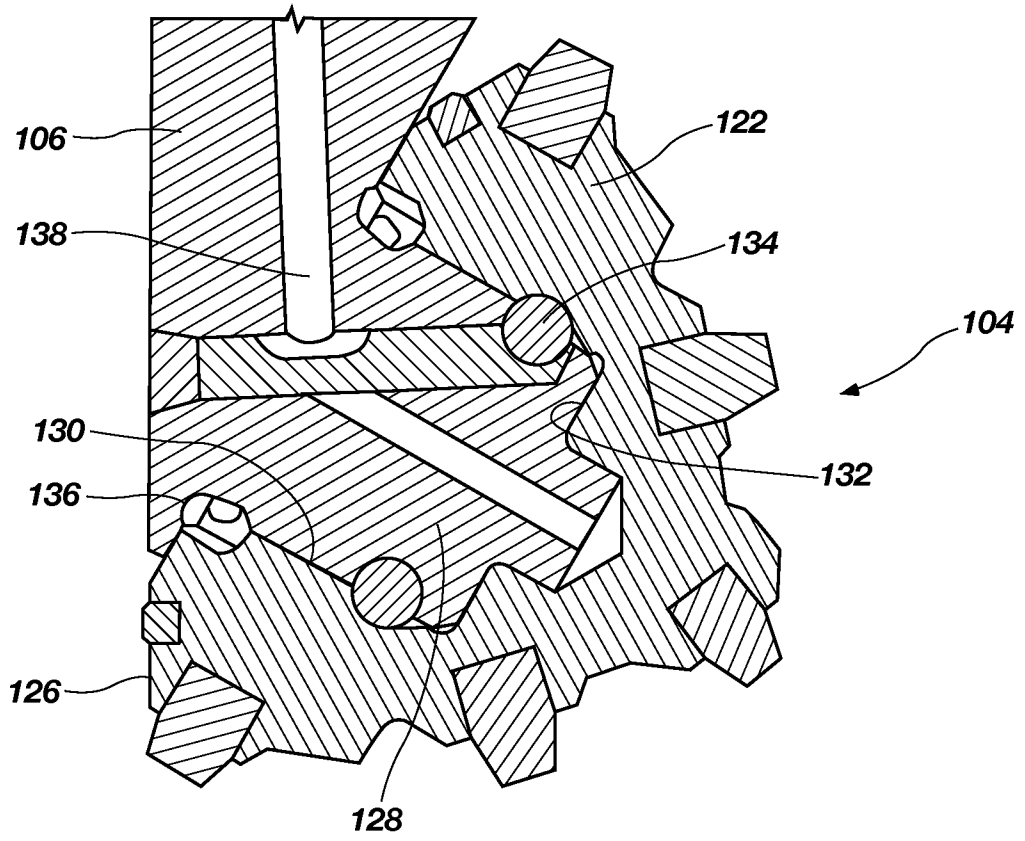
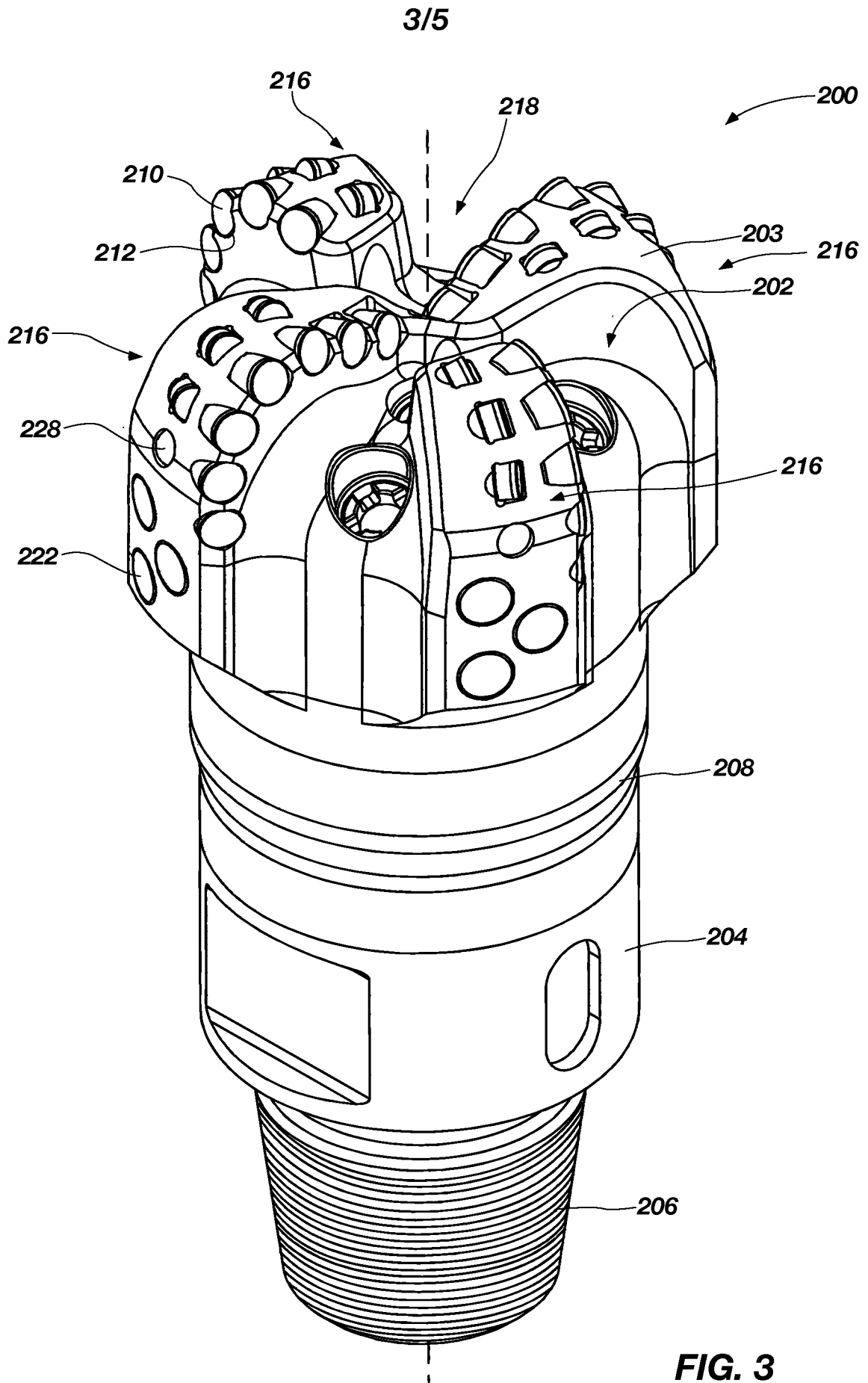

FIG. 1



**FIG. 2**



**FIG. 3**

4/5

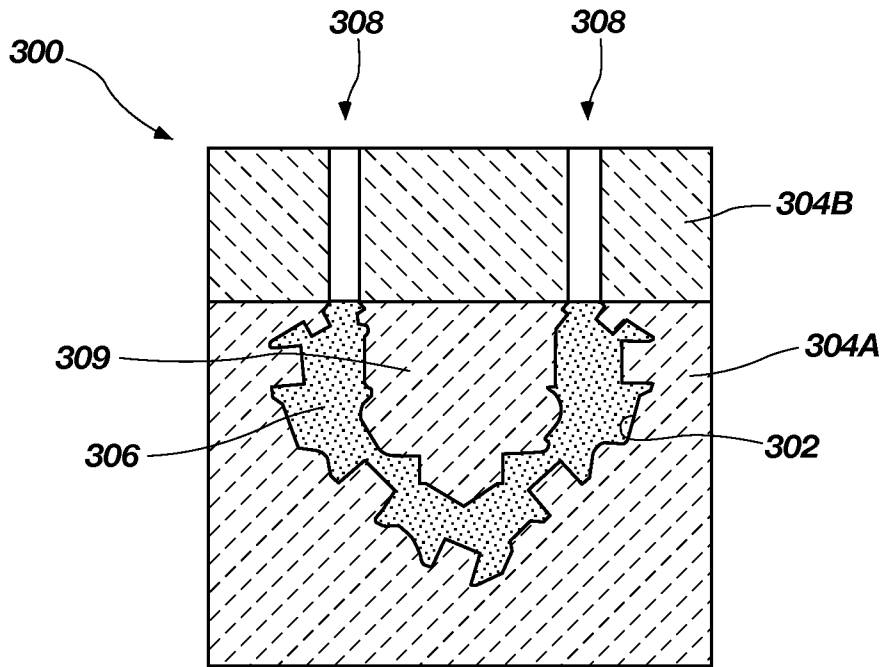

FIG. 4

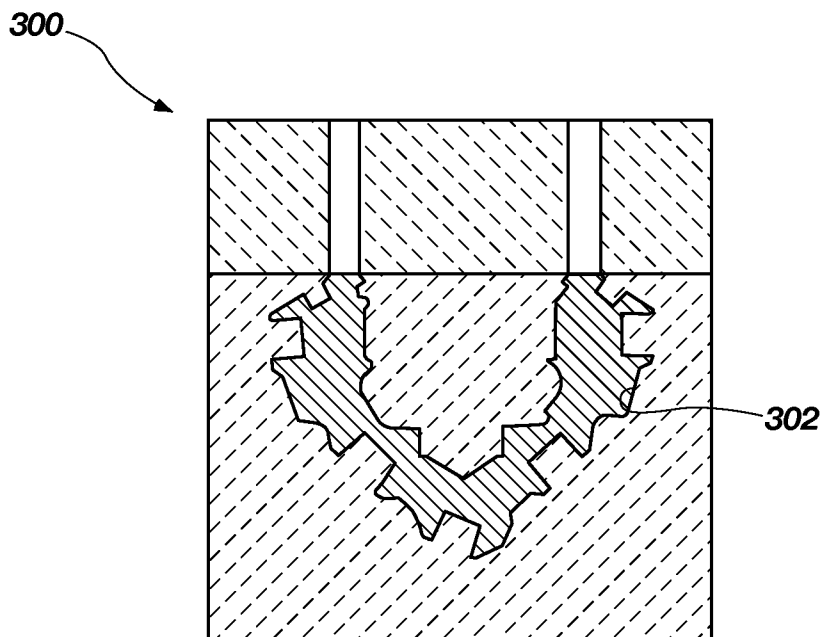
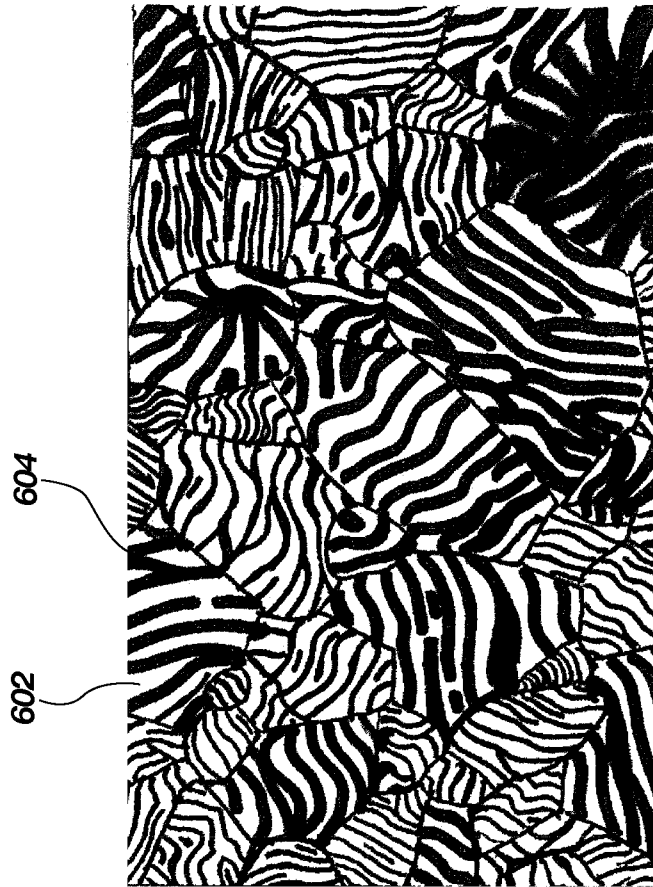

FIG. 5



**FIG. 6**