

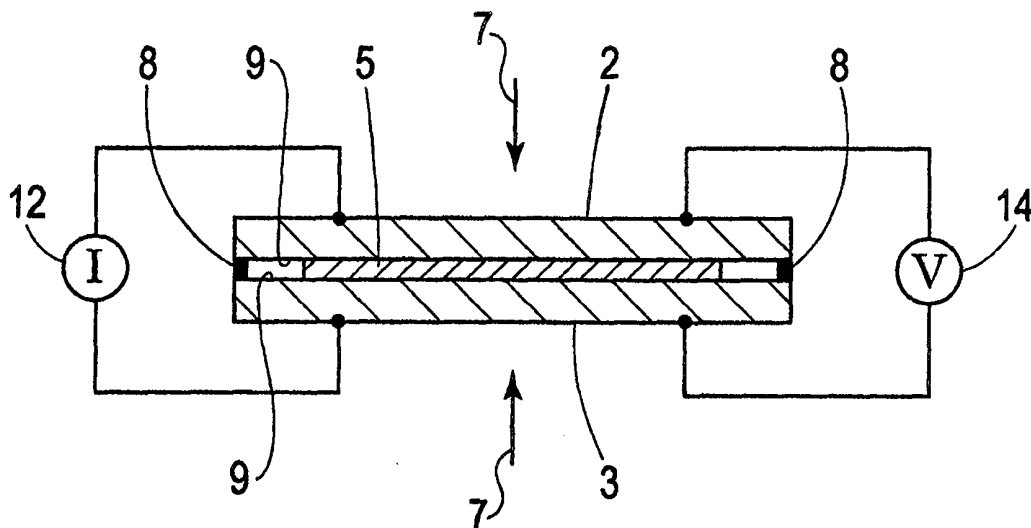

INTERNATIONAL APPLICATION PUBLISHED UNDER THE PATENT COOPERATION TREATY (PCT)

<p>(51) International Patent Classification ⁷ : C04B 35/01, 35/10, 35/12, 41/88 // 111:94</p>	A1	<p>(11) International Publication Number: WO 00/40520</p> <p>(43) International Publication Date: 13 July 2000 (13.07.00)</p>
<p>(21) International Application Number: PCT/AU99/01140</p> <p>(22) International Filing Date: 23 December 1999 (23.12.99)</p> <p>(30) Priority Data: PP 7988 31 December 1998 (31.12.98) AU</p> <p>(71) Applicant (for all designated States except US): CERAMIC FUEL CELLS LIMITED [AU/AU]; 170 Browns Road, Noble Park, VIC 3174 (AU).</p> <p>(72) Inventor; and (75) Inventor/Applicant (for US only): JAFFREY, Donald [AU/AU]; 2 Bonnieview Road, Mount Dandenong, VIC 3767 (AU).</p> <p>(74) Agents: HUNTSMAN, Peter, H. et al.; Davies Collison Cave, 1 Little Collins Street, Melbourne, VIC 3000 (AU).</p>	<p>(81) Designated States: AE, AL, AM, AT, AU, AZ, BA, BB, BG, BR, BY, CA, CH, CN, CR, CU, CZ, DE, DK, DM, EE, ES, FI, GB, GD, GE, GH, GM, HR, HU, ID, IL, IN, IS, JP, KE, KG, KP, KR, KZ, LC, LK, LR, LS, LT, LU, LV, MA, MD, MG, MK, MN, MW, MX, NO, NZ, PL, PT, RO, RU, SD, SE, SG, SI, SK, SL, TJ, TM, TR, TT, TZ, UA, UG, US, UZ, VN, YU, ZA, ZW, ARIPO patent (GH, GM, KE, LS, MW, SD, SL, SZ, TZ, UG, ZW), Eurasian patent (AM, AZ, BY, KG, KZ, MD, RU, TJ, TM), European patent (AT, BE, CH, CY, DE, DK, ES, FI, FR, GB, GR, IE, IT, LU, MC, NL, PT, SE), OAPI patent (BF, BJ, CF, CG, CI, CM, GA, GN, GW, ML, MR, NE, SN, TD, TG).</p> <p>Published With international search report.</p>	

(54) Title: ELECTRICALLY CONDUCTIVE CERAMICS



(57) Abstract

A metal oxide ceramic material such as alumina or chromia which has been rendered electrically conductive through its thickness by the incorporation of silver into the material. The metal oxide ceramic material may be in the form of a layer on a substrate such as a bipolar plate or other component for a fuel cell assembly. The electrical conductivity may be achieved by heating the ceramic material and a silver-containing material in contact with each other to at least 750 °C such that silver migrates from the silver-containing material into the metal oxide ceramic material and creates electrically conductive pathways through the ceramic material. In a particular embodiment, the substrate is a steel which forms an alumina, chromia or alumina-rich or chromia-rich surface layer in oxidising atmosphere and the silver-containing material is heated in an oxidising atmosphere in contact with the steel to cause the surface layer to form on the steel and to cause silver from the silver-containing material to occur in and create the electrically conductive pathways through the layer. The silver-containing material may be commercially pure silver or other forms of silver.

FOR THE PURPOSES OF INFORMATION ONLY

Codes used to identify States party to the PCT on the front pages of pamphlets publishing international applications under the PCT.

AL	Albania	ES	Spain	LS	Lesotho	SI	Slovenia
AM	Armenia	FI	Finland	LT	Lithuania	SK	Slovakia
AT	Austria	FR	France	LU	Luxembourg	SN	Senegal
AU	Australia	GA	Gabon	LV	Latvia	SZ	Swaziland
AZ	Azerbaijan	GB	United Kingdom	MC	Monaco	TD	Chad
BA	Bosnia and Herzegovina	GE	Georgia	MD	Republic of Moldova	TG	Togo
BB	Barbados	GH	Ghana	MG	Madagascar	TJ	Tajikistan
BE	Belgium	GN	Guinea	MK	The former Yugoslav Republic of Macedonia	TM	Turkmenistan
BF	Burkina Faso	GR	Greece	ML	Mali	TR	Turkey
BG	Bulgaria	HU	Hungary	MN	Mongolia	TT	Trinidad and Tobago
BJ	Benin	IE	Ireland	MR	Mauritania	UA	Ukraine
BR	Brazil	IL	Israel	MW	Malawi	UG	Uganda
BY	Belarus	IS	Iceland	MX	Mexico	US	United States of America
CA	Canada	IT	Italy	NE	Niger	UZ	Uzbekistan
CF	Central African Republic	JP	Japan	NL	Netherlands	VN	Viet Nam
CG	Congo	KE	Kenya	NO	Norway	YU	Yugoslavia
CH	Switzerland	KG	Kyrgyzstan	NZ	New Zealand	ZW	Zimbabwe
CI	Côte d'Ivoire	KP	Democratic People's Republic of Korea	PL	Poland		
CM	Cameroon	KR	Republic of Korea	PT	Portugal		
CN	China	KZ	Kazakstan	RO	Romania		
CU	Cuba	LC	Saint Lucia	RU	Russian Federation		
CZ	Czech Republic	LI	Liechtenstein	SD	Sudan		
DE	Germany	LK	Sri Lanka	SE	Sweden		
DK	Denmark	LR	Liberia	SG	Singapore		
EE	Estonia						

- 1 -

ELECTRICALLY CONDUCTIVE CERAMICS

The present invention relates to electrical conductivity in metal oxide ceramic materials and
5 the creation of electrical conductivity in a normally non-conductive ceramic material. It has
application in providing electrical conductivity across a layer of ceramic material. In a
particular application the layer of metal oxide ceramic is adhered to a metal plate and this has
special application in components of solid oxide fuel cells.

10 Alumina is well known as an electrical insulator and as a material which is physically and
chemically stable at high temperatures. Its electrical properties are put to good use in many
high temperature applications where electrical isolation is desired. However, it would be
useful in many applications to have a material which has the high temperature stability of
alumina while also having good electrical conductivity. It would be particularly useful if thin
15 layers or sheets of alumina or other metal oxide ceramics could be made electrically
conductive through the ceramic in selected locations.

It has now been found that the application of silver metal, in any of a variety of forms, to the
surface of a fully dense or porous body of metal oxide ceramic such as alumina or chromia,
20 followed by a sustained heat treatment at temperatures in the range 750°C-970°C or above,
can cause the ceramic to develop electrical conductivity, especially in the immediate vicinity
of the silver. The conductivity so imparted to the ceramic may be a volume effect, that is,
the conductivity may be imparted both laterally and through the thickness of the ceramic
body. The body may be a layer, sheet, film or thin plate. However, with a body having a
25 very small thickness, the effect may be principally through the ceramic.

Thus according to a first aspect of the present invention there is provided a metal oxide
ceramic material which has been rendered electrically conductive through its thickness by the
incorporation of silver into the material.

- 2 -

Preferably the ceramic material is alumina, but it may alternatively be, for example, chromia, or alumina-rich or chromia-rich ceramic.

Preferably the metal oxide ceramic material has a thickness of no more than 1 mm, more
5 preferably no more than 10 μm .

In a preferred embodiment, the metal oxide ceramic material is a layer on a substrate. The substrate may be of any suitable material on which the layer can be provided. The layer of metal oxide ceramic material can be applied by any suitable means to the substrate, or it may
10 be grown on the substrate, for example as in the case of a self-aluminising steel, that is a steel having an aluminium content of greater than 4.5 wt%.

In a solid oxide fuel cell the electrolyte, anode and cathode are normally ceramic materials. However, the surrounding structural components of a fuel cell stack may be of any material
15 which can provide the required electrical conduction properties and structural strength to the stack assembly, at the temperatures necessary for operation of the fuel cell, for example in excess of 700°C. These components may be made of a ceramic or metal capable of handling the conditions. Some of these components, for example bipolar plates (also known as interconnect plates), are required to provide electrical connection between adjacent fuel cells.
20 Sophisticated electrically conductive ceramics have been developed for this purpose but these materials are expensive, mechanically fragile and are poor thermal conductors when compared with many metals capable of handling the conditions.

The operating conditions in a solid oxide fuel cell are very severe on most metals, causing
25 them to degrade via loss of mechanical strength, oxidation or other form of corrosion, distortion, erosion and/or creep. Various heat resistant metals have been developed to cope with many of these forms of degradation. Most such metals are alloys based on iron or nickel with substantial additions of chromium, silicon and/or aluminium, plus, in some alloys, more expensive elements such as cobalt, molybdenum and tungsten. Chromium based metals are
30 also available.

- 3 -

The significant feature of all heat resistant steels is the oxide layer which is formed when the steel is exposed to mildly or strongly oxidising conditions at elevated temperatures. They all form tight, adherent, dense oxide layers which prevent further oxidation of the underlying metal. These oxide layers are composed of chromium, aluminium or silicon oxides or some
5 combination of these depending upon the composition of the steel. They are very effective in providing a built-in resistance to degradation of the underlying steel in high temperature oxidising conditions.

However, while this feature is used to great advantage in many applications, the presence of
10 the oxide layer is highly deleterious to the use of these steels in key components of solid oxide fuel cells. These oxides, especially those of silicon and aluminium, are electrically insulating at all temperatures and this is a major problem for those fuel cell components which must act as electrical current connectors. For these heat resisting steels to be useful for electrical conducting components in fuel cells, it is imperative that the insulating effect of the oxide
15 layer be alleviated at least in selected locations.

According to a second aspect of the invention, there is provided a component formed of steel having a surface layer of alumina, chromia or alumina-rich or chromia-rich ceramic, said layer having been rendered electrically conductive through its thickness by the incorporation
20 of silver into the layer.

The ceramic layer protects the underlying metal from chemical interactions while the electrical conductivity provided by the silver allows it to provide electrical contact with the underlying metallic component.
25

The silver may be incorporated into the layer as the layer is formed on the steel or after the layer has been formed on the steel. Preferably, the layer is formed by surface oxidation of the steel, for example as in the case of a self-aluminising steel.

30 For fuel cell and other applications, an advantage of the present invention is that a material such as alumina which is universally renowned for its excellent thermal and electrically

- 4 -

insulating properties, as well as its chemical inertness, can have one of these three properties reversed without impairing the other two. The invention can provide, with alumina, a material which is still an excellent refractory material and inert in nearly all environments, but which is electrically conductive at least in selected positions. This is of special
5 significance for various connections required in fuel cell assemblies. The effect has been found to be durable over long periods of time and over the full temperature range required for solid oxide fuel cell operation. The invention has been used to advantage to convert otherwise highly insulating alumina coated metal bipolar plates to conducting plates which can be used to collect current from operating fuel cells. The conductivity can be used as a sole
10 means of current collection or used as a safeguard/backup in case a prime current collector mechanism fails.

The mechanism by which the silver migrates into or occurs in the metal oxide ceramic is not fully understood at this time. However, it is believed that the electrical conductivity is
15 provided by the silver extending along grain boundaries of ceramic material. Incorporating the silver into the ceramic material can be achieved by heating the silver-containing material in contact with the ceramic material or with a substrate on which the ceramic material is formed.

20 According to a third aspect of the invention there is provided a method of providing electrical conductivity through metal oxide ceramic material including placing a silver-containing material into contact with the ceramic material and heating the ceramic and silver-containing materials in contact with each other to at least 750°C such that silver migrates from said silver-containing material into said layer of metal oxide ceramic material and creates
25 electrically conductive pathways through the ceramic material.

The atmosphere in which the method is performed does not appear to be important and is conveniently air. The method is conveniently performed at atmospheric pressure.

30 According to a fourth aspect of the invention there is provided a method of forming a steel component with a heat-resistant and electrically conductive surface layer, said method

- 5 -

including selecting a steel which forms an alumina, chromia or alumina-rich or chromia-rich surface layer in oxidising atmosphere, placing a silver-containing material in contact with the surface of the steel, heating the steel and silver-containing material to at least 750°C in an oxidising atmosphere to cause said surface layer to form on the steel and to cause silver from
5 said silver-containing material to occur in and to create electrically conductive pathways through the layer.

Preferably the steel used in the method of the fourth aspect of the invention has an aluminium content of above 4.5 wt % .

10

Preferably, the heating step in the methods of the invention is to at least 800°C, more preferably at least 850°C, even more preferably at least 900°C and most preferably at least 950°C. It is believed that while the effect of the silver imparting electrical conductivity to the metal oxide ceramic material will occur at 750°C, or even less, the rate of the effect occurring
15 is very slow at this temperature and increases with increasing temperature. The effect occurs especially quickly when the silver is in a liquid state.

The silver-containing material is preferably at least commercially pure silver, but it may be an alloy or otherwise contain selected impurities which are not severely detrimental to the
20 effect of imparting electrical conductivity to a metal oxide ceramic material. Such impurities or alloying elements may include one or more of the noble metals, Sn, Cu and Ni.

The silver-containing material may be in sheet, mesh, paste or other appropriate form. The silver-containing material may be provided on a substrate of a type which is acceptable to the
25 end result.

Embodiments of the invention will now be described, by way of example only, with reference to the Examples and to the accompanying drawings in which:

30 Figure 1 is a diagrammatic representation of an experimental arrangement used to investigate the nature of the invention;

- 6 -

Figure 2 is a plot of results recorded from an experiment of the form shown in Figure 1; and

Figure 3 is a plot of results recorded from a variant of the experiment shown in Figure 1.

5

Example 1

Referring to Figure 1, two coupons 2 and 3 of clean, polished, heat resistant chromium-rich stainless steel approximately 1.0 cm square and 1 mm thick had sandwiched between them a square piece of silver foil 5 having a plan area of 0.864 cm². The sandwich structure was clamped together, as indicated by arrows 7, with a force of 6N. Seals 8 between the coupons, around their edge portions, were pliable at elevated temperature and took no significant load.

The facing surfaces 9 of the coupons 2 and 3 were maintained in an atmosphere of gently flowing dry air, facilitated by an array of straight parallel grooves (not shown) machined into the facing surfaces 9. The complete assembly was heated to 900°C and maintained there for over 70 hours. A constant DC electric current of about 200 mA/cm² was maintained between the coupons 2 and 3 by means of a current generator 12 and the voltage across the coupons was measured by a meter 14. The material of seals 8 was an electrically insulating glass so the measured voltage indicated the change in resistance in the electrical path between the two coupons 2 and 3. The steel in the coupons had a composition of about 27% Cr, 0.05% C, 0.05% Al and 0.05% Si by weight so its heat resistance and chemical resistance properties derive from the formation of a thin chromia layer on the surface of the steel in the oxidising atmosphere.

25

By the time the first reading was taken after heating to 900°C, a thin chromia layer had developed on the surfaces 9.

As seen from Figure 2, the resistance then dropped from 2 milliohm to 0.3 milliohm over 70 hours of operation. During this period it would have been expected that the resistance would increase due to thickening of the chromium oxide layer on the surfaces 9 of the coupons in

30

- 7 -

contact with the silver foil. Removal and examination of the coupons revealed a chromia layer had been generated on the facing surfaces 9 but that the chromia was electrically conductive through its thickness where the silver had been in contact with it. It is believed that the silver penetrates the growing chromia layer and improves its conductivity. A similar
5 result is achieved if the chromia layer is preformed on the stainless steel. If the same experiment were performed with a stainless steel foil instead of the silver foil, the chromia layer produced on the surfaces 9 would provide a resistance in the range of thousands of ohms per square centimetre instead of the thousandths of ohms per square centimetre found using the silver foil.

10

Example 2

In a further experiment using a similar apparatus to that of Example 1, the coupons used were similar to those described above, but of a stainless steel which produces an alumina protective
15 coating when heated. Such stainless steels are known as self-aluminising and have an Al content of greater than 4.5 wt%. These were heated at 1025°C in air for 1 hour to produce a coating of tightly adhered alumina approximately 1 to 2 μm thick on the exposed surface. The alumina coating was electrically insulating, with a resistance in excess of 3000ohm/cm² (measured to a clean polished surface at the rear face). The coupons were then assembled as
20 shown in Figure 1, with the alumina-coated surfaces facing each other and with silver mesh taking the place of foil 5, and held in air at 850°C. The mesh was made from silver wire of about 50 μm diameter woven at about 120 μm centres. The results are shown in Figure 3. After 420 hours the resistance across the sandwich had dropped to about one third of its starting value and was continuing to reduce. The 1 to 2 μm thick tightly adherent layer of
25 alumina had become electrically less resistive at the places where the silver mesh was in contact with it. A similar result is achieved if the alumina layer is formed after the silver material has been placed in contact with the stainless steel.

30

Example 3

It has been found that it is not necessary for the foil or mesh used to be of solid silver. When an expanded metal mesh made from stainless steel and electrocoated with silver was substituted for the solid silver mesh used in Example 2, the resistance of the alumina layer reduced in the same manner. It therefore appears that only small quantities of silver are required to be transferred to the alumina in order for the electrical conductivity effect to occur.

10 Example 4

In a further variation of Example 2, a small quantity of silver paste was substituted for the silver mesh. The clamped coupons were then exposed to an air atmosphere at approximately 950°C. The resistance was observed to drop at a much faster rate than with the silver mesh at 850°C.

Example 5

In a further variation of Example 2, the surfaces of the stainless steel coupons were polished to remove any oxide coating and the silver paste of Example 4 was applied between the polished surfaces of the coupons before any heating. The coupons were then heated in air at temperatures from 800°C to 970°C. Although an alumina coating quickly established itself on the surface of the steel, its resistance remained less than 10 milliohm/cm². The coating remained conductive when the temperature was reduced to ambient and through many such heating and cooling cycles. The silver and silver paste is quite pervious to oxygen, so the alumina layer is not prevented from developing on the surface of the steel, but it does develop with a low electrical resistivity.

The behaviour of the chromia and alumina in the way described was surprising. The noble metals, including silver, have been used to bond bulk alumina components together, but electrical conduction was not the aim, nor has it been reported as an outcome. The structure

- 9 -

of the conductive chromia and alumina has not yet been properly determined, nor has the mechanism by which the silver produces the conductivity in the oxide. While not intending to be bound by any theory, it is thought that when heated, small amounts of the silver are drawn threadlike along grain boundaries in the oxide and create an open mesh arrangement
5 of silver threads or strands within the alumina such that there is eventually created a continuous path of silver along the grain boundaries through the full thickness of the layer of oxide.

Much effort has been spent developing heat resistant steels for bipolar plates for solid oxide
10 fuel cells. Self-aluminising steels have particular advantages at the high operating temperatures required. If the coated surface is damaged in some way, it becomes self healing as aluminium in the steel diffuses to the exposed surface where it oxidises to form a new protective coating of alumina. The alumina coating also has the beneficial property of totally blocking any escape of chromium from the steel. This is important because even small traces
15 of chromium-based gases in an atmosphere will quickly and permanently reduce the performance of a solid oxide fuel cell. However the great benefits of self-aluminising steels have often been forgone because of the need to have the surface of the plate function as an electrical current collector, and this has been incompatible with alumina's properties as an electrical insulator. Thus the emphasis has been to develop steels which do not produce an
20 alumina-rich layer upon their surface when exposed to oxidising atmospheres at high temperatures. In contrast, the present invention means that the benefits of an alumina coating may be obtained without the disadvantage of its high electrical resistance.

In addition to bipolar plates, the invention may be used for other components of fuel cells,
25 particularly solid oxide fuel cells, such as current collector straps and heat exchangers.

Fuel cell components, and bipolar plates in particular, made in accordance with the second aspect of the invention with an alumina or alumina-rich layer may be superior to those obtainable with other heat resistant materials currently available in one or more of the
30 following properties:

- 10 -

- 1) stronger and tougher: steels exhibit good strength and fracture resistance at the operating temperature of the fuel cell and during the warm up and cool down phases;
- 2) cost: the cost of fuel cell components in accordance with the invention is less than
5 other materials which have been used for interconnect plates in solid oxide fuel cells, e.g. Ni alloys, austenitic stainless steels, chromium alloys and ceramics;
- 3) oxidation resistance: the components have an excellent, inherent resistance to surface degradation at temperatures within the range 500°C to 950°C in the atmospheres usually
10 present in a solid oxide fuel cell, viz moist air, moist hydrogen, moist hydrocarbons and oxides of carbon; and
- 4) electrical conductivity: the alumina or alumina-rich layer is electrically conductive from its exposed surface through to the underlying metal, thus providing a direct pathway for
15 electrical contact and current flow through the component.

It is probable that in addition to its use with fuel cells, the invention has advantages in many areas of technology where insulating and conducting elements are used in close proximity and/or stable electrical properties at elevated temperatures are required. Technologies such
20 as thick and thin film printed circuit boards, microelectronics, semiconductors, wave guides and sensors could benefit from the invention. There are many potential uses for alumina or chromia which is electrically conductive either in total or in selected areas.

Those skilled in the art will appreciate that the invention described herein is susceptible to
25 variations and modifications other than those specifically described. It is to be understood that the invention includes all such variations and modifications which fall within its spirit and scope.

CLAIMS

1. Metal oxide ceramic material which has been rendered electrically conductive through its thickness by the incorporation of silver into the material.
5
2. Metal oxide ceramic material according to claim 1 wherein said thickness is no more than 1 mm.
3. Metal oxide ceramic material according to claim 2 wherein said thickness is no more
10 than 10 μm .
4. Metal oxide ceramic material according to any one of the preceding claims wherein the material is alumina, chromia or alumina-rich or chromia-rich ceramic.
- 15 5. Metal oxide ceramic material according to any one of the preceding claims wherein the silver extends along grain boundaries of the material.
6. Metal oxide ceramic material according to any one of the preceding claims which is a layer on a substrate.
20
7. A component formed of steel having a surface layer of alumina, chromia or alumina-rich or chromia-rich ceramic, said layer having been rendered electrically conductive through its thickness by the incorporation of silver into the layer.
- 25 8. A component according to claim 7 wherein the silver has been incorporated into the layer after the layer has been formed on the steel.
9. A component according to claim 7 or 8 wherein the layer has been formed by surface oxidation of the steel.
30

- 12 -

10. A component according to any one of claims 7 to 9 which is a component for a fuel cell assembly.
11. A component according to claim 10 which is a bipolar plate.
- 5
12. A method of providing electrical conductivity through metal oxide ceramic material including placing a silver-containing material into contact with the ceramic material and heating the ceramic and silver-containing materials in contact with each other to at least 750°C such that silver migrates from the silver-containing material into the metal oxide
10 ceramic material and creates electrically conductive pathways through the ceramic material.
13. A method according to claim 12 wherein the silver-containing material is at least commercially pure silver.
- 15 14. A method according to claim 12 wherein the silver-containing material is an alloy of silver.
15. A method according to any one of claims 12 to 14 wherein the silver-containing material is provided on a substrate.
- 20
16. A method according to any one of claims 12 to 15 wherein the metal oxide ceramic material is provided as a layer on a substrate.
17. A method according to any one of claims 12 to 16 wherein the metal oxide ceramic
25 material is alumina, chromia or alumina-rich or chromia-rich ceramic.
18. A method of forming a steel component with a heat-resistant and electrically conductive surface layer, said method including selecting a steel which forms an alumina, chromia or alumina-rich or chromia-rich surface layer in oxidising atmosphere, placing a
30 silver-containing material in contact with the surface of the steel, heating the steel and silver-containing material to at least 750°C in an oxidising atmosphere to cause said surface layer

- 13 -

to form on the steel and to cause silver from said silver-containing material to occur in and create electrically conductive pathways through the layer.

19. A method according to claim 18 wherein the steel has an aluminum content of above
5 4.5 wt%.

20. A method according to claim 18 or 19 wherein the silver-containing material is at least commercially pure silver.

10 21. A method according to any one of claims 12 to 20 wherein the silver-containing material is in the form of a sheet, a mesh or a paste.

22. A method according to any one of claims 12 to 21 wherein said heating is to at least
800°C, more preferably at least 850°C, even more preferably at least 900°C and most
15 preferably at least 950°C.

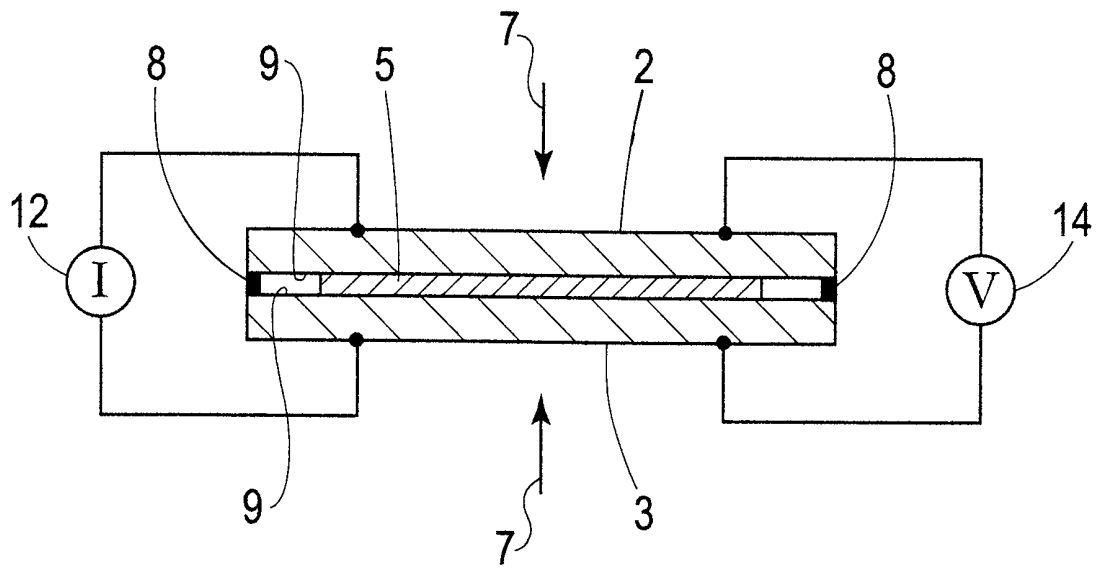

FIGURE 1

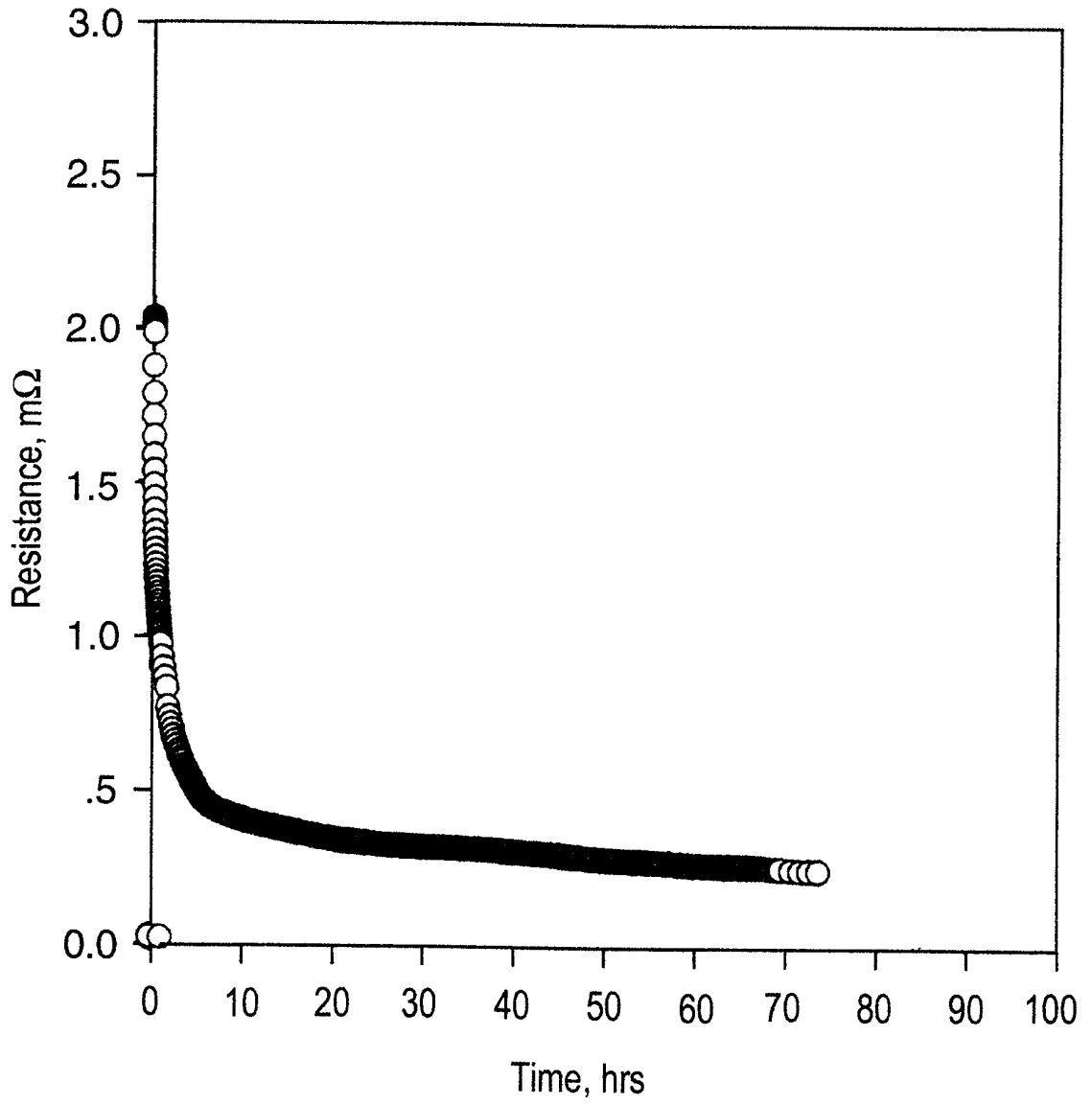

FIGURE 2

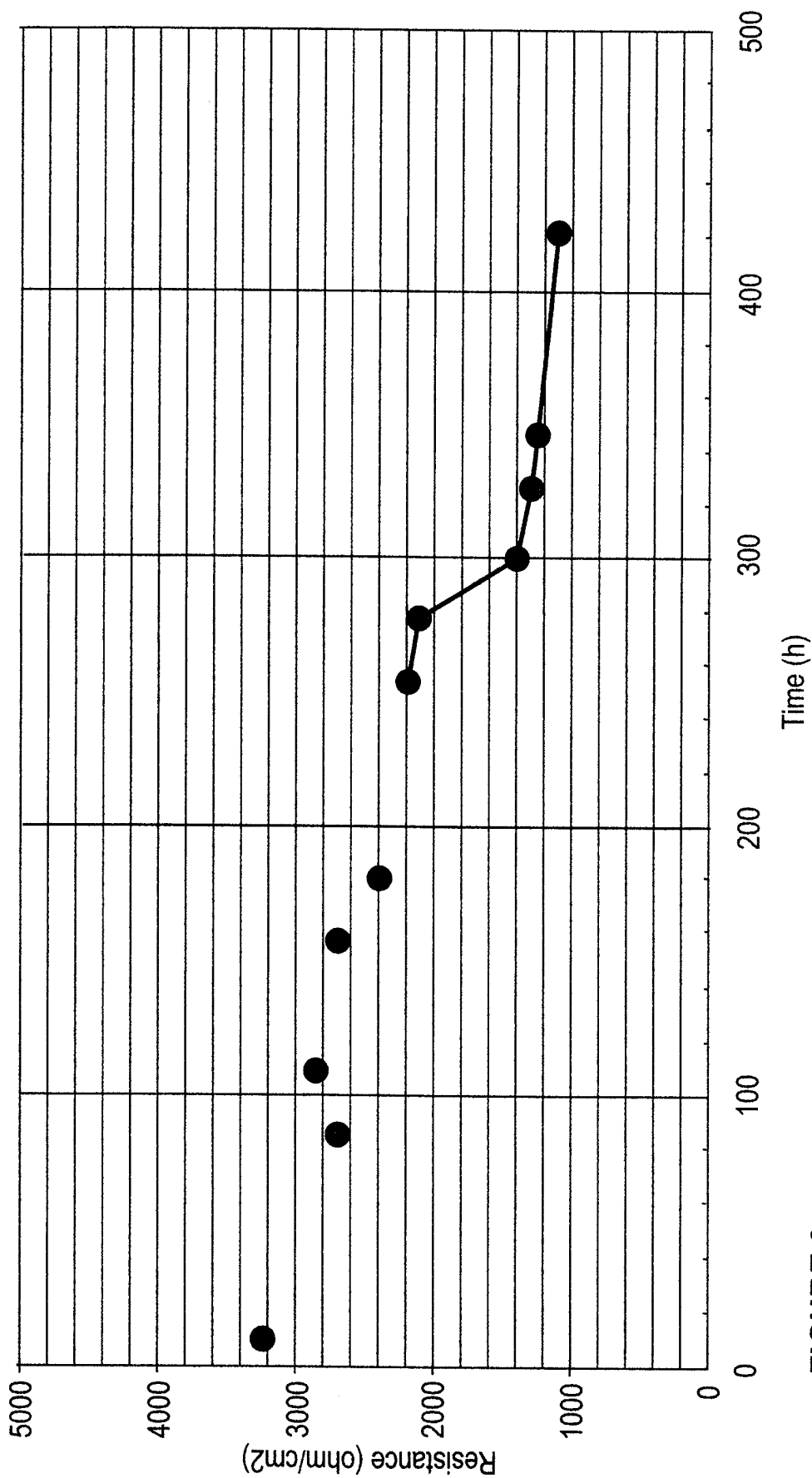

FIGURE 3

INTERNATIONAL SEARCH REPORT

International application No. PCT/AU 99/01140

A. CLASSIFICATION OF SUBJECT MATTER					
Int Cl ⁷ : C04B 35/01, 35/10, 35/12, 41/88; 111:94					
According to International Patent Classification (IPC) or to both national classification and IPC					
B. FIELDS SEARCHED					
Minimum documentation searched (classification system followed by classification symbols) C04B 35/01, 35/10, 35/12, 41/88					
Documentation searched other than minimum documentation to the extent that such documents are included in the fields searched					
Electronic data base consulted during the international search (name of data base and, where practicable, search terms used) WPAT, JAPIO (C04B + Keywords)					
C. DOCUMENTS CONSIDERED TO BE RELEVANT					
Category*	Citation of document, with indication, where appropriate, of the relevant passages	Relevant to claim No.			
X	US 3963522 A (HARADA) 15 June 1976 See abstract, claim 1	1,12			
X	US 5318723 A (HASHEMI) 7 June 1994 See abstract, example 3	1			
X	US 5753574 A (DONALDSON) 19 May 1998 See abstract, column 6, line 51-column 7, line 8	1			
<input checked="" type="checkbox"/> Further documents are listed in the continuation of Box C <input checked="" type="checkbox"/> See patent family annex					
<table style="width: 100%; border: none;"> <tr> <td style="width: 33%; vertical-align: top;"> <p>* Special categories of cited documents:</p> <p>"A" Document defining the general state of the art which is not considered to be of particular relevance</p> <p>"E" earlier application or patent but published on or after the international filing date</p> <p>"L" document which may throw doubts on priority claim(s) or which is cited to establish the publication date of another citation or other special reason (as specified)</p> <p>"O" document referring to an oral disclosure, use, exhibition or other means</p> <p>"P" document published prior to the international filing date but later than the priority date claimed</p> </td> <td style="width: 33%; vertical-align: top;"> <p>"T" later document published after the international filing date or priority date and not in conflict with the application but cited to understand the principle or theory underlying the invention</p> <p>"X" document of particular relevance; the claimed invention cannot be considered novel or cannot be considered to involve an inventive step when the document is taken alone</p> <p>"Y" document of particular relevance; the claimed invention cannot be considered to involve an inventive step when the document is combined with one or more other such documents, such combination being obvious to a person skilled in the art</p> <p>"&" document member of the same patent family</p> </td> <td style="width: 33%;"></td> </tr> </table>			<p>* Special categories of cited documents:</p> <p>"A" Document defining the general state of the art which is not considered to be of particular relevance</p> <p>"E" earlier application or patent but published on or after the international filing date</p> <p>"L" document which may throw doubts on priority claim(s) or which is cited to establish the publication date of another citation or other special reason (as specified)</p> <p>"O" document referring to an oral disclosure, use, exhibition or other means</p> <p>"P" document published prior to the international filing date but later than the priority date claimed</p>	<p>"T" later document published after the international filing date or priority date and not in conflict with the application but cited to understand the principle or theory underlying the invention</p> <p>"X" document of particular relevance; the claimed invention cannot be considered novel or cannot be considered to involve an inventive step when the document is taken alone</p> <p>"Y" document of particular relevance; the claimed invention cannot be considered to involve an inventive step when the document is combined with one or more other such documents, such combination being obvious to a person skilled in the art</p> <p>"&" document member of the same patent family</p>	
<p>* Special categories of cited documents:</p> <p>"A" Document defining the general state of the art which is not considered to be of particular relevance</p> <p>"E" earlier application or patent but published on or after the international filing date</p> <p>"L" document which may throw doubts on priority claim(s) or which is cited to establish the publication date of another citation or other special reason (as specified)</p> <p>"O" document referring to an oral disclosure, use, exhibition or other means</p> <p>"P" document published prior to the international filing date but later than the priority date claimed</p>	<p>"T" later document published after the international filing date or priority date and not in conflict with the application but cited to understand the principle or theory underlying the invention</p> <p>"X" document of particular relevance; the claimed invention cannot be considered novel or cannot be considered to involve an inventive step when the document is taken alone</p> <p>"Y" document of particular relevance; the claimed invention cannot be considered to involve an inventive step when the document is combined with one or more other such documents, such combination being obvious to a person skilled in the art</p> <p>"&" document member of the same patent family</p>				
Date of the actual completion of the international search 02 March 2000		Date of mailing of the international search report 8 MAR 2000			
Name and mailing address of the ISA/AU AUSTRALIAN PATENT OFFICE PO BOX 200 WODEN ACT 2606 AUSTRALIA E-mail address: pct@ipaaustralia.gov.au Facsimile No.: (02) 6285 3929		Authorized officer JAMES DZIEDZIC Telephone No.: (02) 6283 2495			

INTERNATIONAL SEARCH REPORT

International application No.

PCT/AU 99/01140

C (Continuation). DOCUMENTS CONSIDERED TO BE RELEVANT		
Category*	Citation of document, with indication, where appropriate, of the relevant passages	Relevant to claim No.
X	EP 256963 (LANXIDE) 24 February 1988 See abstract, example 5 and page 5, line 2	1
X	US 5767029 A (SCHULER) 16 June 1998 See abstract	1
X	Derwent Abstract Accession No: 95-085243/12, Class U14, JP 7-10639 A (AGENCY OF INDIA) 13 January 1995 See abstract	1
X	Derwent Abstract Accession No: 93-097296/12, Class U11, JP 5-41110 A (NIPPON CEMENT) 19 February 1993 See abstract	1
X	Derwent Abstract Accession No: 92-386261/47, Class L03, JP 4-285085 A (TOSHIBA) 9 October 1992 See abstract	1
X	Derwent Abstract Accession No: 91-167311/23, Class V04, JP 3-99487 A (SHINKO DENKI) 12 September 1989 See abstract	1
X	Derwent Abstract Accession No: 90-264397/35, Class X12, JP 2-184555 A (MATSUSHITA) 12 January 1989 See abstract	1
X	Derwent Abstract Accession No: 77-56238y, Class L03, JP 52-32596 A (TDK) 11 March 1977 See abstract	1

INTERNATIONAL SEARCH REPORT

Information on patent family members

International application No. PCT/AU 99/01140
--

This Annex lists the known "A" publication level patent family members relating to the patent documents cited in the above-mentioned international search report. The Australian Patent Office is in no way liable for these particulars which are merely given for the purpose of information.

Patent Document Cited in Search Report		Patent Family Member					
US	3963522	GB	1464405	JP	50078830	US	3963522
US	5318723	AU	50891/90	CA	2046597	EP	457810
		WO	90/9669				
US	5753574	NONE					
EP	256963	AU	76220/87	BG	50271	BR	8703516
		CA	1294992	CN	87105586	CS	8705630
		DD	284670	DK	3892/87	FI	873078
		HU	46619	IL	83094	IN	168339
		JP	63050360	NO	872854	NZ	220947
		PH	25041	PL	267166	PT	85451
		SU	1676457	TR	23797	US	4868143
		YU	1430/87	US	5106698	US	5122488
		US	5266415	AU	20135/88	CA	1300919
		DK	4182/88	EP	301340	HK	462/91
		IL	87178	JP	1131757	LT	2430
		LV	5634	NO	883320	PH	264482
		PT	88100	SU	1605930	TR	23502
		US	4821995				
US	5767029	CA	2190331	EP	776872		
JP	7-10639	NONE					
JP	5-41110	NONE					
JP	4-285085	NONE					
JP	3-99487	NONE					
JP	2-184555	NONE					
JP	52-32596	US	4098725	JP	51062395		
END OF ANNEX							