

(19) **DANMARK**

(10) **DK/EP 2931078 T3**



Patent- og
Varemærkestyrelsen

(12) **Oversættelse af
europæisk patentskrift**

-
- (51) Int.Cl.: **A 45 C 11/18 (2006.01)**
- (45) Oversættelsen bekendtgjort den: **2020-02-03**
- (80) Dato for Den Europæiske Patentmyndigheds bekendtgørelse om meddelelse af patentet: **2019-11-06**
- (86) Europæisk ansøgning nr.: **13830240.1**
- (86) Europæisk indleveringsdag: **2013-12-17**
- (87) Den europæiske ansøgnings publiceringsdag: **2015-10-21**
- (86) International ansøgning nr.: **NL2013050909**
- (87) Internationalt publikationsnr.: **WO2014098580**
- (30) Prioritet: **2012-12-17 NL 2009993** **2013-12-16 NL 2011970**
- (84) Designerede stater: **AL AT BE BG CH CY CZ DE DK EE ES FI FR GB GR HR HU IE IS IT LI LT LU LV MC MK MT NL NO PL PT RO RS SE SI SK SM TR**
- (73) Patenthaver: **R.J. van Geer Beheer bv, Haagweg 163, 2281 AJ Rijswijk, Holland**
- (72) Opfinder: **Van Geer, Rene Johan, Haagweg 163, 2281 AJ Rijswijk, Holland**
- (74) Fuldmægtig i Danmark: **Patrade A/S, Ceresbyen 75, 8000 Århus C, Danmark**
- (54) Benævnelse: **Kreditkortholder med forbedret kort-ejektor**
- (56) Fremdragne publikationer:
EP-A2- 0 287 532
WO-A2-2010/137975
JP-A- S60-1 794 84U
US-A- 4 887 739
US-A1- 2002 074 246

DESCRIPTION

[0001] The invention relates to a card holder provided with a device (further also called "ejector") to eject or dispense the cards, or different flat or plate like objects, from the holder and wherein the card or cards tightly fit within the holder, for which the holder has a cavity similar to the shape and slightly bigger than the card or cards stack.

[0002] The prior art discloses such holders for cards, designed to address the problem of easily selecting the desired card from a stack placed in the holder. Document EP-A 0 287 532 discloses a holder shaped as a flat box or sleeve, in which the stack of cards tightly fits. This housing has inside a pivoting ejector arm which by means of a finger button projecting through a curved elongate opening in the holder wall can be pivoted, with the effect that the stack of cards slides outwards. Since the ejector arm is provided with a relief profile such that each card engages with a different edge at the ejector arm, the cards are dispensed as a staggered stack. CH702919 B1 discloses a similar card holder. WO2010137975 (of the present inventor Van Geer) also discloses a card holder with an implement to present a staggered stack of cards, partly projecting out the card holder. US5718329 discloses an at both ends open sleeve like card holder. A card ejector is lacking.

[0003] All these prior art holders are prone to jamming of the ejector arm during daily use. JP S60-1794 84 U A is also cited.

[0004] The object of the invention is versatile. In one aspect the object is a card holder which is less prone to jamming of the ejector arm. In another aspect the object is to offer a comfortable, simple and accurate operation of the holder with long life. Other aspects can be learned from the specification, drawings or claims. Two or more aspects can be combined.

[0005] The invention is directed to a holder for cards according to claim 1. The card holder dispenses the complete stack of cards in such a manner that a staggered stack of cards, partly projecting out the card holder, is presented. For example, the ejector device is designed to provide that the stack of cards is partly projected from the card holder, wherein the cards are presented in a staggered fashion, while when completely contained within the housing, the cards are

in register (in other words the cards are not staggered). By presenting the cards in staggered fashion, they can be easily individually identified and individually taken from the stack by two fingers of the hand of the user. The card holder is preferably rigid in relation to the typical loads to which the card holder is exposed during normal daily use.

[0006] According to the invention, which is defined in the claims, this object is obtained by allowing the ejector arm to deflect, in the direction towards and away from the opposite main sides of the holder. The design of the card holder is such that the ejector arm can deflect at least 0.2 millimeter, preferably at least 0.35 millimeter, most preferably at least 0.5 millimeter, such value being on top of the typical fabrication tolerances of the assembled card holder. In

other words, such dimension should be present if the ejector arm in its operative position is stably supported by the relevant surface of the associated holder main side. Such deflection is allowed by providing a gap, preferably of sufficient said dimension (at least 0.1 or 0.35 or 0.5 millimeter), between the relevant part of the ejector arm and the associated main side of the holder, such that the ejector arm can move in and out said gap while deflecting.

[0007] To allow such deflection, the ejector arm is provided with a convenient feature to allow deflection.

[0008] The ejector arm is designed to deflect at an intermediate area along its length, such that on both longitudinal sides of this area such deflection is absent. Such is obtained by providing that said gap is present at said intermediate area while said gap is absent at both longitudinal sides of this area. In practice such could be obtained by providing this intermediate area with a recess facing the associated holder main side, such recess providing the desired gap. Advantageously such recess is provided such that if the ejector arm in its operative, unloaded position is supported by the flat surface of the holder main side, said intermediate area keeps said gap with said holder main side surface while at both longitudinal sides of the intermediate area the ejector arm bears with a support area onto the holder main side surface. Consequently, if the ejector arm is loaded to deflect towards the main side, the intermediate area will enter the gap and makes it smaller. Obviously, such support area is designed to slide across the associated surface of the holder main side.

[0009] Preferably the intermediate area at least partly or completely overlaps with at least part of the ejector arm area bearing the features, e.g. relief profile, for ejecting the cards stack in staggered fashion. In an embodiment said intermediate area partly overlaps with said relief profile bearing area and also extends some distance beyond said relief profile bearing area, preferably towards the location where the ejector arm is mounted to the holder body, e.g. for a distance of at least 5 millimeter, preferably at least 9 millimeter, more preferably at least 12 millimeter.

[0010] In a development the ejector arm at its side opposite its side bearing the intermediate area has a bearing face intermediate the free tip and the mounting location of the ejector arm, which bearing face slidably engages the main side. Said bearing face preferably is located at a longitudinal distance from the free tip corresponding to a distance approximately midway the length of the intermediate area, e.g. somewhere between one third and two third the length of the intermediate area.

[0011] In an embodiment the ejector arm has two longitudinally spaced first bearing surfaces at its side facing the one holder body main side and a single second bearing surface at its opposite side (facing the other holder body main side). The first bearing surfaces preferably have the intermediate area (for deflection) between them. The second bearing surface preferably is located between the first bearing surfaces, more preferably approximately midway, e.g. somewhere between one third and two third the longitudinal distance, between the first bearing surfaces. The first and second bearing surfaces will slide across the

associated holder body main side and in this manner the ejector arm is stably guided by the holder body.

[0012] In a preferred development such deflection is facilitated by adding flexibility to the ejector arm, preferably in the direction towards and away from the opposite main sides of the holder. Preferably this flexibility is obtained by a small wall thickness, preferably in the area between the location where the ejector arm is mounted to the holder body and the for engagement with the cards provided relief profile at the ejector arm. Preferably the wall thickness is small in the complete area between the relief profile and the mounting to the holder body. Practically, the flexibility is such that the free tip of the operatively mounted ejector arm will deflect at least 1 millimeter, preferably at least 3 millimeter, more preferably at least 5 millimeter towards a main side when loaded at the free tip by a force of 1 kilogram directed towards said main side and the ejector arm is fixedly clamped at its mounting point.

[0013] In particular the holder is designed to receive and dispense credit cards (and different items with dimensions comparable to credit cards, further mentioned as "cards"), preferably wherein a stack of, e.g. at least three, four or five, cards can be housed in the holder, more preferably wherein the cards in the stack are immediately mutually superposed or adjacent, in other words not further object is or needs be present between adjacent cards. The holder preferably has two pairs of substantially or completely closed and fixed opposite sides, one pair with length and width almost equal to the same card dimensions (also called the "main sides") and this pair spaced by the other (also called the "minor sides") pair (delimiting the stack thickness) such that the card stack tightly fits between these four sides. Preferably these sides are thin walled and/or provide a rigid, sleeve like casing. Of the remaining pair of two opposite sides preferably one (also called the "bottom") is permanently substantially or completely closed and the other (also called the "top") is open but could be temporary closed, e.g. by a lid, such that the holder has merely a single open side through which the cards can enter and exit the holder. Thus the holder provides a rigid sleeve with closed bottom.

[0014] Preferably the holder is provided with means to keep the cards within the holder without closing the top side with a lid, e.g. friction means which e.g. engage the thin sides of the cards, such as e.g. disclosed by WO2010137975.

[0015] The ejector comprises an ejector element (further also called "arm") moving between a first and second (preferably a retracted and an extended, respectively) position inside the holder and engaging the cards stack, preferably engaging an edge of the cards, to push the cards stack out of the holder while the cards move in a plane parallel to their main faces, preferably such that the cards (with the element in its extended position) partly project from the holder in a stepped or staggered manner. For the purpose of presenting or dispensing the cards in a stepped manner, the element is provided with a relief profile, preferably having some relation with the thickness of the cards, such that the element has a plurality of spaced features, preferably located along a straight line, a such feature designed to engage a single card from the stack, such that by movement of the element within de holder, the one card is moving with the element for a further distance outward compared to another card from the

same stack within the holder. In an embodiment such features are projections at the element each providing an engagement edge, wherein preferably the projections project a different distance from the element such that each engagement face is present at a different level. Preferably the element is designed such that, in its retracted position, the cards fit within the holder such that the cards are mutually in register, in other words, present a neat stack.

[0016] The thickness of the ejector arm stepwise increases from the free end (in other words the distal end or the end remote from the pivot point or the end opposite the end to which the drive means engage or are mounted). This stepwise increase of thickness provides step shaped features for ejecting the cards stack in a staggered fashion.

[0017] In its extended position, the ejector arm preferably extends diagonally within the holder. In its retracted position, the ejector arm preferably extends parallel to an external side or edge of the holder, preferably opposite the side from which the cards are dispensed from within the holder. Preferably the ejector arm rotates or swivels or turns or hinges or pivots between its first and second position, for which it is preferably provided with a hinge or pivot feature, such as a pin or hole, with which it is mounted to the holder. In the alternative a translating movement is feasible.

[0018] To provide the movement of the ejector arm, the ejector comprises a drive means associated with the ejector arm. This is a manually operated drive means, namely a finger operated button. The ejector arm and the drive means are connected in a rigid manner such that the movement of the drive means is directly transferred to the ejector arm and both these members move as one, since both these members are integrated in a single, rigid piece. The ejector arm and/or drive means could be injection moulded parts, e.g. of polymeric or plastic or equivalent material.

[0019] Preferably the ejector arm provides a base or bottom of the holder, preventing exit of the cards from the associated side of the holder.

[0020] For the so called credit card format the main dimensions suffice ISO 7810 and the thickness and roundings suffice ISO 7813. This format is used for many cards with different applications: bank cards, driving licences, ID-cards, membership cards, entrance cards, reduction cards, savings cards, etc.

[0021] The invention is based on the teaching that cards of credit card format indeed have a standardised thickness, but this has always some dispersion due to unavoidable fabrication tolerances. Also, cards are not always as flat as they should be, they e.g. warp in time due to use. With the holders with ejector arm presently known, jamming occurs due to such imperfect cards. Also imperfect flatness of the main walls of the holder can cause jamming. Jamming can either require increased manual force to operate the ejector device, or can cause immovability of the ejector device. Typically the jamming location corresponds to an individual feature, e.g. step, of the means for ejecting the cards in a staggered fashion and depends on the number and type of cards stacked between such feature and the corresponding main side. Thus, for

the same holder, the jamming location can the one time be at the one and another time at the other of the plurality of steps, such that the ability to deflect according to the invention is preferably provided for at least most or substantially all of the steps.

[0022] The card ejector feature gives the user the opportunity to partly slide the card stack from the housing. This is a preferred operation before the user can select a card and remove it from the housing.

[0023] If the card in a stepped stack is slid from the housing, each card shows a narrow edge and the user can see at a blink which cards are present in the holder. Also the user can easy and quick select within the cards stack the desired card and remove it by manually sliding the cards mutually in a direction equal to or opposite the direction in which the cards are slid from the housing from their stored position

[0024] An embodiment of the ejector arm is provided with a reset means, e.g. a spring, with the effect that this ejector arm after operation will always immediately and automatically return to the initial position, such that without obstruction the user can slide cards back into the housing during making a selection from the partly exposed cards.

[0025] Information stored electromagnetically in the cards, can be damaged by the influence of strong electromagnetic radiation fields. Also cards provided with a RFID chip can be contactless read by means of radio waves if they are near an adapted reader. These are two examples of the mostly undesired interaction that can happen between electromagnetic radiation and cards in the housing. An embodiment of the card holder of the invention which excludes these influences has a housing made of a galvanic material. The geometry of the housing of this invention lends itself for fabrication by means of metal extrusion, with which a proper Faraday cage is made.

[0026] A possible embodiment which allows further protection from external influences, like moist and dirt, comprises a housing which can be closed with e.g. a pivoting lid or a flexible part, e.g. a rubber cap.

[0027] The invention will now be further explained by way of the drawing, in which Fig. 1-5 relate to the prior art.

Fig. 1 - 3 show the operation of the ejector arm of a card holder, in perspective (fig. 2 and 3 also in side view);

Fig. 4 and 5 show in perspective view two movement possibilities of the ejector arm, mounted within a card holder which is shown in sectional view;

Fig. 6 shows a presently preferred embodiment of the ejector arm of the invention, in side, top and end view; and

Fig. 7 shows the ejector arm of fig. 6 more in detail.

[0028] Fig. 1 - 3 show a perspective view of the housing of the card holder which tightly fits around the shown stack of at least three cards (four are shown), wherein one of the two longitudinal ends of the housing is referred to as a card opening because it is opened to receive and remove cards. The tightly fit around the card stack implicates a main shape based on a right angled brick, but it can of course, for reasons of design or ergonomics, differ, e.g. by providing chamfers, roundings, ribs, etc.

[0029] Fig. 1 shows the empty holder and the ejector arm in the first and second position, respectively. The engagement faces at different levels projecting from the ejector arm, to eject the cards stack in staggered fashion, are clearly visible. Also visible is the finger button projecting outside the holder and driving the ejector arm.

[0030] Fig. 2 shows the holder filled with four stacked cards in register, the lower side of each card in register with a relevant engagement face of the ejector arm in its first (retracted) position. Starting from this position of the ejector arm and moving (pivoting) it to its second position, the cards will be forced by the associated engagement face such that the cards stack is partly ejected. Since each engagement face has a different distance to the pivot point of the ejector arm, each card will travel a different distance such that a staggered ejected stack is obtained (shown in fig. 3 in which the ejector arm is in its second position).

[0031] Fig. 4 shows in sectional view a holder with a card eject feature provided by the stepped element 16 which can pivot around an axis 17 if the user exerts in the pivot direction (according to the arrow) a force through the actuator 18 outside the housing, or immediately at the operation face 18a as part of the stepped element 16. The stepped element is made from steps, wherein the card contact face 19 can exert force against the side of the cards which faces the ejector arm 16. The card contact faces 19 can be regarded as the thickness of the steps in the stepped shape and the height of these faces is equal to or smaller than the nominal card thickness (approx. 0.8 mm), whereby each step contacts a different card. A reset spring 20 ensures that the stepped element 16 after releasing the button 18 returns immediately and automatically to the initial (first) position shown.

[0032] Fig. 5 shows a possible variant of the embodiment of fig. 4, wherein the stepped element 16 can translate in the direction in which the cards are slid through the card opening 3 and out the housing (illustrated by the arrow) and which by means of a reset spring 20 after releasing the operation part 18 returns immediately and automatically to the initial position. As will be appreciated, the cards stack is also staggered if completely inside the holder, in this embodiment.

[0033] As is clear from all fig. 1-5, the thickness of the ejector arm stepwise decreases from the proximal (close to the pivot point 17) to the distal (free or remote) end 5.

[0034] While it is feasible to design the holder assembly such that for avoiding jamming the tip

5 should deflect relative its associated main side (in other words the nearest main side), the following design is more preferred and fig. 6 and 7 show a presently preferred embodiment:

The main side walls 4 have smooth, level and flat inner faces and the ejector arm is designed to deflect at an intermediate area 6 along its length, such that on both longitudinal sides 7 of this area 6 such deflection is absent. Thus this intermediate area 6 has a recess 8 facing the associated holder main side 4, such recess providing the desired gap. The gap width, according to the orientation of arrow 8, thus the distance between the bottom of the recess and the nearest side 4, is 0.4 millimeter plus typical tolerances. As shown, such recess 8 is provided such that if the ejector arm in its operative, unloaded position is supported by the flat surface 4 side, said intermediate area 6 keeps said gap 8 with said side surface 4 while at both longitudinal sides 7 of the intermediate area 6 the ejector arm bears onto the holder main side surface 4. Consequently, if the ejector arm is loaded (arrow F) to deflect towards the main side 4, the intermediate area will enter the gap such that the gap will become smaller.

[0035] As shown the intermediate area 6 overlaps the ejector arm area bearing the relief profile 19, and also extends some distance beyond said relief profile 19 towards the mounting location 17 where the ejector arm is mounted to the holder body.

[0036] Also, the ejector arm at its side opposite its side bearing the intermediate area 6 has a bearing face 21 intermediate the free tip 5 and the mounting location 17 of the ejector arm, which bearing face 21 slidingly engages the associated main side 4. Said bearing face 21 is located at a longitudinal distance from the free tip 5 corresponding to a distance approximately midway the length of the intermediate area 6, in other words somewhere between one third and two third the length of the intermediate area.

[0037] The force (arrow F) causing jamming of the ejector arm, typically will be located at the bearing face 21 or any of the steps of the relief profile depending on the types of cards in the stack and their deformation (embossed, warped, etc.).

[0038] Thus, the ejector arm shown in fig. 6 and 7 has two spaced first bearing surfaces 7 at its side facing the one holder body main side 4 and a single second bearing surface 21 at its opposite side (facing the other holder body main side 4). The first bearing surfaces 7 delimit the intermediate area 6 (for deflection) between them. The second bearing surface 21 is located, as viewed longitudinally, between the first bearing surfaces 7. The first and second bearing surfaces 7, 21 will slide across the associated holder body main side 4 and in this manner the ejector arm is stably guided by the holder body.

[0039] Further, the deflection of the area 6 to enter the gap is facilitated by adding flexibility to the ejector arm in the direction towards and away from the opposite main sides 4 of the holder. Such flexibility is obtained by a small wall thickness, in the area between the location 17 where the ejector arm is mounted to the holder body and the for engagement with the cards provided relief profile 17 at the ejector arm. As shown, the wall thickness is small in the complete area between the relief profile 19 and the mounting 17 to the holder body.

[0040] Fig. 6 shows the ejector arm with improved flexibility of the invention. In the side view a part of the opposite main sides 4 of the holder are shown in cross section. Clearly, the ejector arm fits tightly between these sides 4, although the clearance is shown exaggerated for illustrative purposes. The dashed line 12 indicates the initial material boundary of a rigid ejector arm. By decreasing the thickness this boundary 12 changed in boundary 9, resulting in an improved flexibility according to the arrow C shown. Thus the deflection towards the nearest side 4 by the intermediate area 6 is facilitated.

[0041] As a consequence of deflection into the gap 8, the relief profile 19, apart from the part of this profile 19 within the area 7 supported by the side 4 (in this embodiment the free tip 5 belongs to this area 7) is now able to move away from the side 4 opposite the side bearing the areas 7. This deflection avoids jamming during ejecting the cards stack.

[0042] Also different embodiments belong to the invention. Features of different in here disclosed embodiments can in different manners be combined and different aspects of some features are regarded mutually exchangeable. All described or in the drawing disclosed features provide as such or in arbitrary combination the subject matter of the invention, also independent from their arrangement in the claims or their referral.

REFERENCES CITED IN THE DESCRIPTION

This list of references cited by the applicant is for the reader's convenience only. It does not form part of the European patent document. Even though great care has been taken in compiling the references, errors or omissions cannot be excluded and the EPO disclaims all liability in this regard.

Patent documents cited in the description

- [EP0287532A](#) [0002]
- [CH702919B1](#) [0002]
- [WO2010137975A](#) [0002] [0014]
- [US5718329A](#) [0002]
- [JP60179484U](#) [0003]

PATENTKRAV

1. Holder til kort, omfattende et hus (1), som passer snævert omkring en stabel med mindst tre kort (2) og omfatter mindst én kortåbning (3) til anbringelse og fjernelse af kort, mens der over for kortåbningen (3) inden i huset er tilvejebragt en kortfjernelsesfunktionalitet, således at kortene gennem kortåbningen (3) kan skubbes delvist ud fra huset, hvilken kortfjernelsesfunktionalitet er udformet til inden i huset at bevæge sig mellem en første og en anden position og under denne bevægelse tvinger kort til delvist at forlade huset,
- 5
- 10 hvorved kortfjernelsesfunktionaliteten er udstyret med en ejektorarm (16), som bevæger sig mellem en første og anden position inden i holderen og griber ind i kortstabilen for at skubbe kortstabilen ud af holderen, mens kortene bevæger sig i et plan, der er parallelt med deres hovedflader, således at kortene delvist rager frem fra holderen på en trindelt eller forsat måde; hvorved ejektorarmen er udstyret med et hjælpeprofil (19), således at ejektorarmen omfatter et antal funktionaliteter med en indbyrdes afstand, hvorved en sådan funktionalitet er udformet til at komme i indgreb med et enkelt kort fra stabilen, således at det enkelte kort ved bevægelse af ejektorarmen inden i holderen sammen med ejektorarmen bevæger sig en yderligere strækning udad, sammenlignet med et andet kort fra samme stabel inden i holderen, hvorved holderen omfatter en funktionalitet til undgåelse af fastklemning af kortejektorfunktionaliteten under indgreb med kortstabilen og de tvinges til at forlade huset,
- 15
- 20
- og
- 25 hvorved ejektorarmen er udformet til at bøje sig i et mellemliggende område i sin længderetning, således at der på begge dette områdes langsider (7) ikke optræder en sådan bøjning, idet der i dette mellemområde findes en spalte (8), mens denne spalte ikke findes ved begge dette områdes langsider,
- hvorved ejektorarmen kan bøje sig mindst 0,2 millimeter, hvilken størrelse kommer oven i de typiske fremstillingstolerancer for den sammenbyggede kortholder,
- og
- 30 ejektorarmen omfatter et drivmiddel, der er knyttet til ejektorarmen (16); hvilket drivmiddel er en fingerbetjent knap (18), hvorved ejektorarmen og drivmidlet er integreret i et enkelt, stift stykke, således at drivmidlets bevægelse direkte overføres til ejektorarmen, og begge disse elementer bevæger sig som en enhed.

2. Kortholder ifølge krav 1, hvorved ejektorarmen kan bøje sig mindst 0,35 eller mindst 0,5 millimeter, hvilken værdi ligger uden for de typiske fremstillingstolerancer for den sammenbyggede kortholder.
- 5 3. Kortholder ifølge krav 1 eller 2, hvorved mellemområdet i det mindste delvist eller helt overlapper med mindst en del af ejektorarm-området, der bærer reliefprofilet, med henblik på udstødning af kortstabilen på forsåt vis.
- 10 4. Kortholder ifølge et af kravene 1-3, hvorved der på husets inderside befinder sig et friktionselement, som udøver en friktionskraft på hvert enkelt korts sidekant inden i huset, hvorved friktionselementet er tilstrækkeligt dimensioneret til samtidig at komme i indgreb med alle kort i stablen og/eller ikke er stift.
- 15 5. Kortholder ifølge et af kravene 1-4, hvorved der i optagerummet befinder sig en stabel med mindst tre retvinklede kort, som vender mod hinanden, med i det væsentlige identiske dimensioner og hver for sig med en første side og en overfor liggende side, og idet friktionselementet befinder sig i fastholdende indgreb i udglidningsretningen fra kortåbningen med den mod friktionselementet vendende side af hvert kort sideværts forspændt således, at den anden side for hvert kort trykkes mod optagerum-
- 20 mets side og fastholdes af denne, mens afstanden mellem den første og den anden side af dette kort er forskellig fra samme afstand for et andet kort i stablen.

DRAWINGS

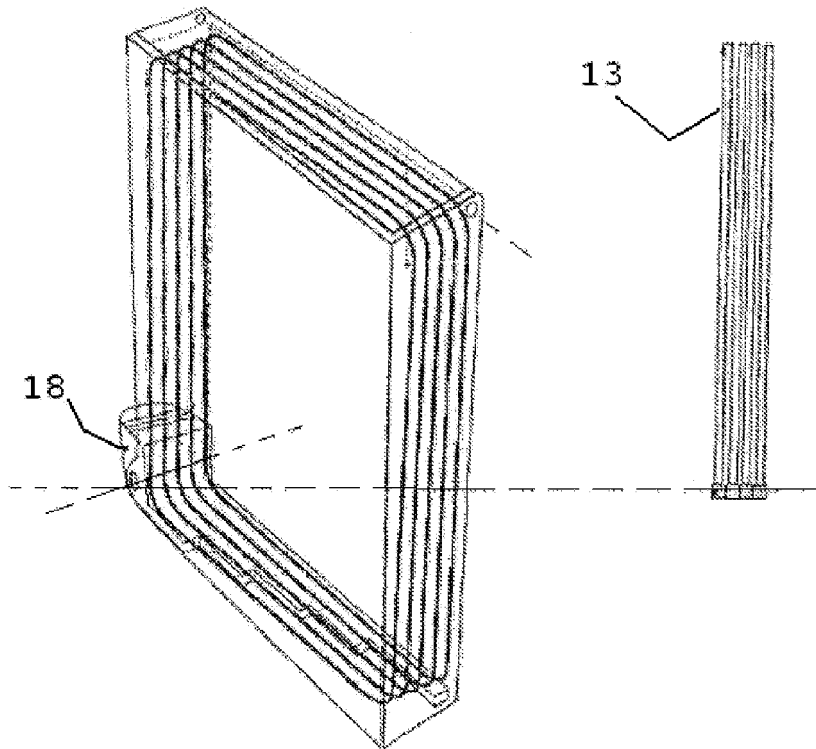
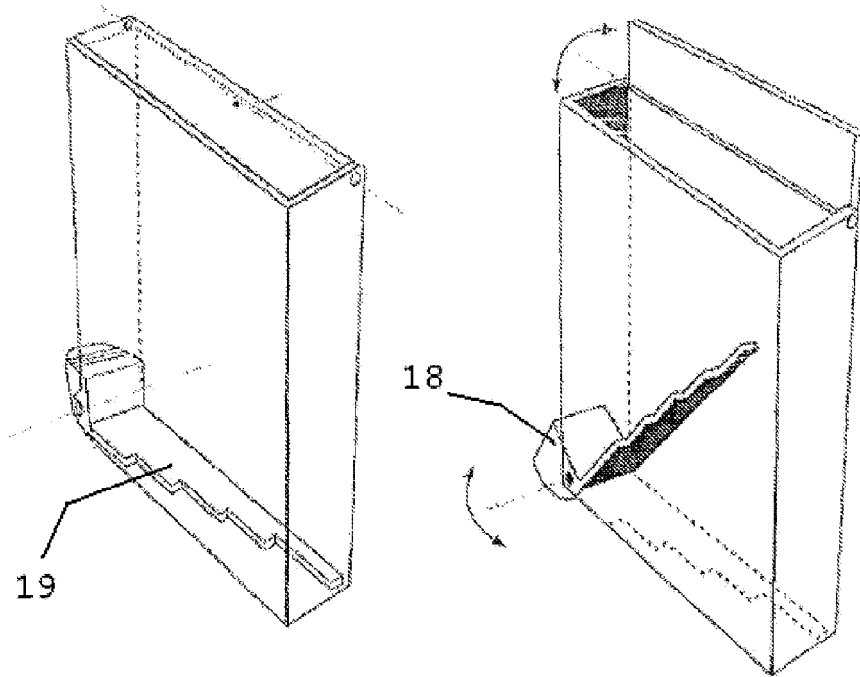

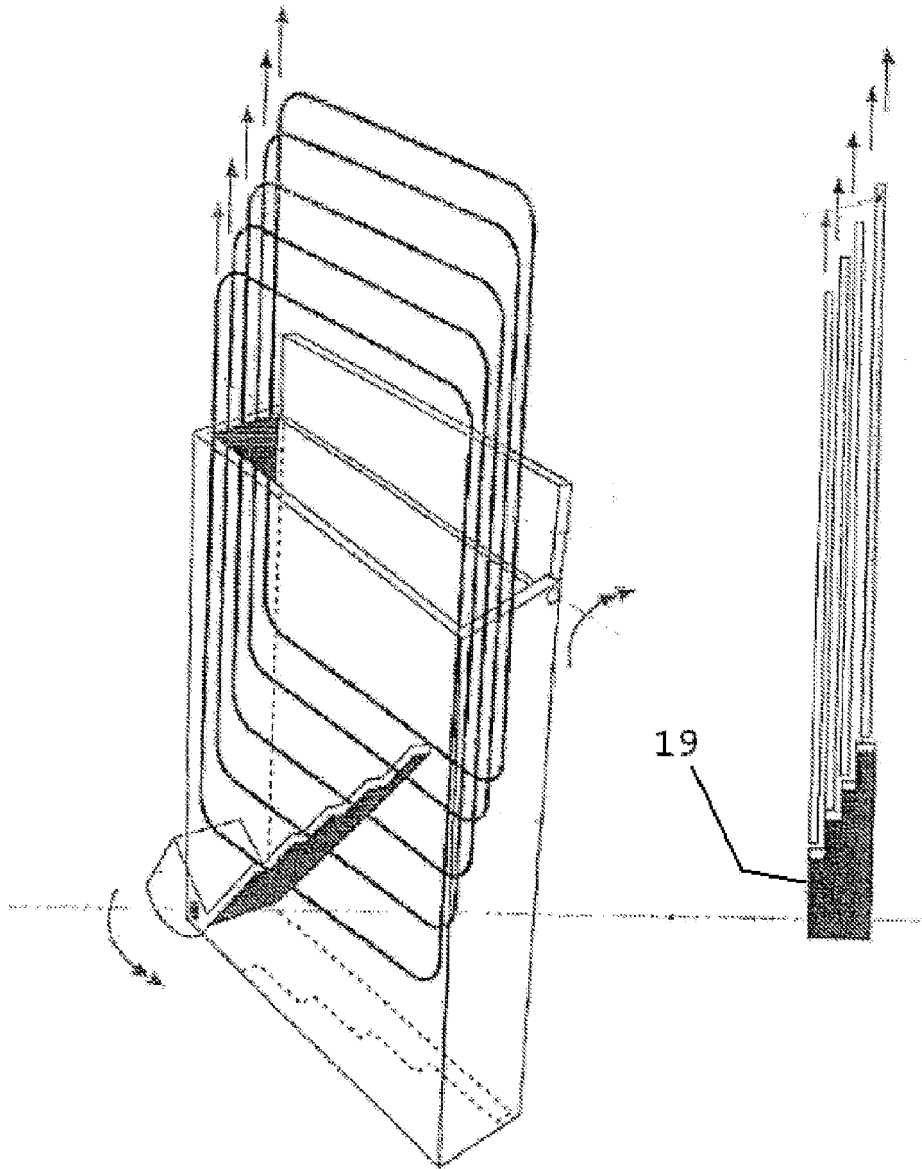
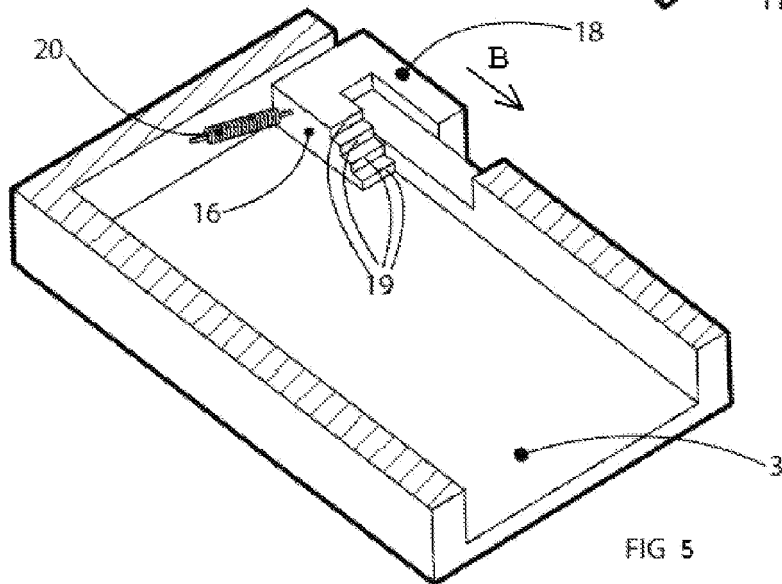
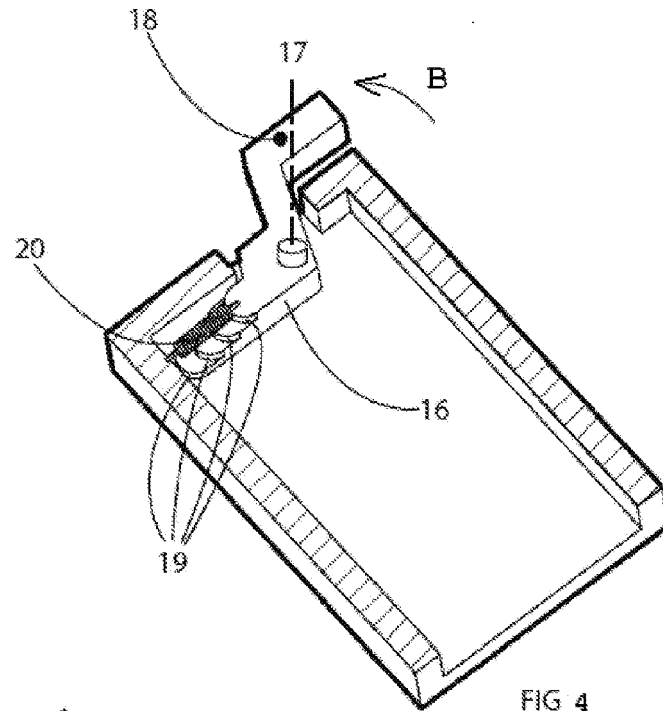

Fig. 3



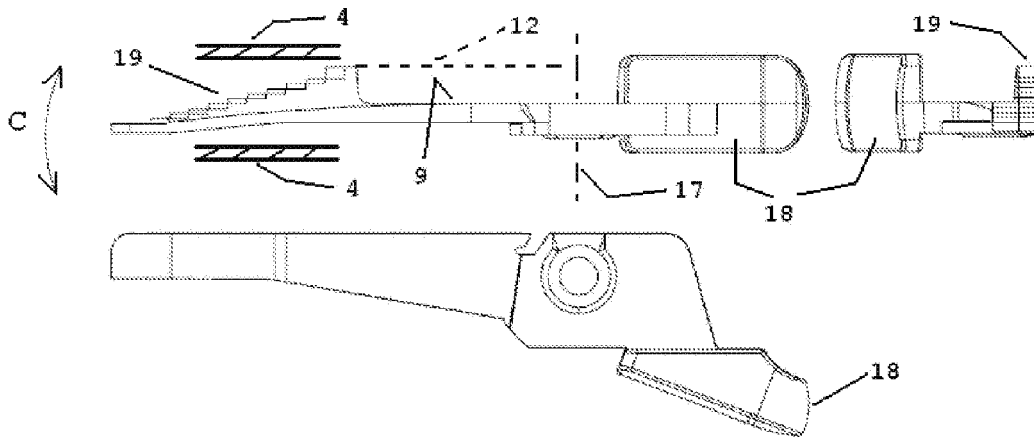

Fig. 6

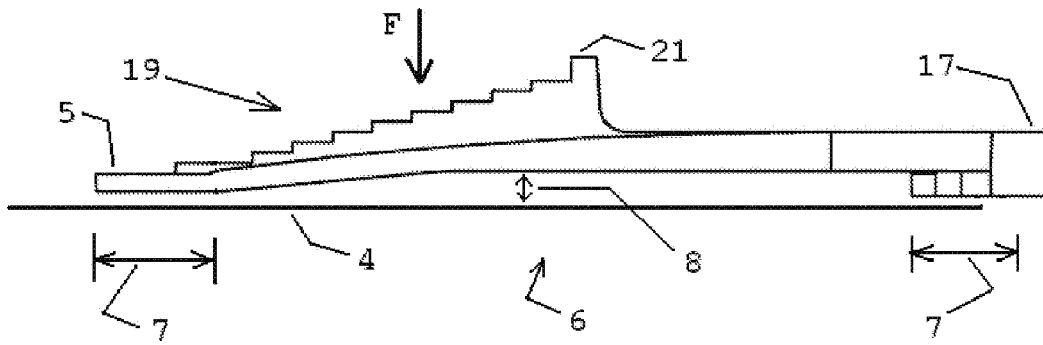

Fig. 7