

(19) **DANMARK**

(10) **DK/EP 2676111 T3**



(12)

Oversættelse af
europæisk patentskrift

Patent- og
Varemærkestyrelsen

-
- (51) Int.Cl.: **G 01 L 5/22 (2006.01)**
- (45) Oversættelsen bekendtgjort den: **2016-05-02**
- (80) Dato for Den Europæiske Patentmyndigheds bekendtgørelse om meddelelse af patentet: **2016-02-03**
- (86) Europæisk ansøgning nr.: **12747821.2**
- (86) Europæisk indleveringsdag: **2012-02-16**
- (87) Den europæiske ansøgnings publiceringsdag: **2013-12-25**
- (86) International ansøgning nr.: **IL2012000084**
- (87) Internationalt publikationsnr.: **WO2012111007**
- (30) Prioritet: **2011-02-19 US 201161444733 P**
- (84) Designerede stater: **AL AT BE BG CH CY CZ DE DK EE ES FI FR GB GR HR HU IE IS IT LI LT LU LV MC MK MT NL NO PL PT RO RS SE SI SK SM TR**
- (73) Patenthaver: **Watteam Ltd, Hamagal Street , Moshav Yodfat , M.P. Misgav, 20180 Yodfat, Israel**
- (72) Opfinder: **DAVID, Eliyahu, Moshav Yodfat, M.P. Misgav, 20180 Yodfat, Israel**
GAL-ON, Ofir, Moshav Yodfat, M.P. Misgav, 20180 Yodfat, Israel
- (74) Fuldmægtig i Danmark: **RWS Group, Europa House, Chiltern Park, Chiltern Hill, Chalfont St Peter, Bucks SL9 9FG, Storbritannien**
- (54) Benævnelse: **EN ANORDNING, FREMGANGSMÅDE OG SYSTEM TIL ADD ON FASTGØRELSE AF EN BELASTNINGSSENSOR FOR DEN PÅ ET TRÆNINGSDSTYR PÅFØRT KRAFT**
- (56) Fremdragne publikationer:
WO-A1-02/20094
DE-A1- 4 227 586
US-A1- 2005 178 210
US-A1- 2010 018 307

DESCRIPTION

Abstract

[0001] The present invention is a device method and system that allow the easy add on attachment of an applied-power sensor, assuring precise measurements over time, even in vibrating environments such as exercise environments.

[0002] The device possesses structural qualities such that tightening the wrapping latch around a measured object/part presses a loaded spring between the object/part and the sensor, achieving and maintaining sufficient and constant contact, thus allowing continuously precise measuring.

[0003] The device also includes a transmitter to transmit the measured data to an external data processing device and may include a processor to process the data before transmitting.

Field of the invention

[0004] The present invention relates to the fields of athletic exercise and recreational devices and equipment, and to a device, method and system for attaching, measuring and displaying precise forces applied by the user of such devices. More specifically, the present invention allows the add-on attachment of force-measuring-sensors to moving parts in exercise apparatuses, with no recourse to the dismantling of any mechanisms or parts, in a way which maintains continuously precise measurements.

Background of the Invention

[0005] It is necessary in the field of athletic exercise to provide people (such as bicycle riders) who are interested in their level of performance, in particular their power output, with add-on applied-force sensor device which is easy to attach and is able to produce and transmit precise measurements even in a vibrating environment. Applications include for example, measuring and displaying the driving torque applied to the crank arm in stationary or usual bicycle. To that end, the prior art, such as (U.S. Pat. No. US7,775,128B2; US7,806,006B2; US7,599,806B2; US7,257,468B1; US6,418,797B1; US5,758,735; US5,591,908; US5,257,540; US5,031,455; US 4,423,630;), teaches a method and device of applied force sensing device for use while cycling.

[0006] DE4227586 discloses the ergometer separately measuring all four possible elastic deformations which can occur in a pedal lever, i.e. bending in the rotation direction, bending perpendicular to this direction, extension along the lever and torsion about the lever. The direction and amplitude of the force applied by the rider to the pedal are derived using Hook's equation or elasticity theory. The force is measured at many different angular positions of the pedal. One revolution is divided into a large number of small angle intervals, between which the force is quantised and the time recorded. The forces acting on the steering mechanism and saddle are determined from the elastic deformations of the handlebar and saddle stem respectively in three orthogonal directions. USE/ADVANTAGE - For training with sports equipment, e.g. cycle. Enables optimal motions to be determined and taught to sportsman.

[0007] WO/2002/20094 discloses a device for determining tread force transmitted to a tread crank, comprising a housing fixed to a tread crank by means of a threaded bolt and an adjustable spacer. A pedal fixture is disposed inside the housing and pivotally mounted around an axis with a spring tongue which acts against a possible pivoting movement of the pedal fixture. A tread force acting upon the pedal and the fixture connected thereto pivots the fixture around the axis until the proportion of the tread force causing the excursion of the pedal fixture corresponds to the elastic force applied by the spring tongue. A Hall sensor which is fixed in a stationary manner inside the housing measures the relative excursion of a permanent magnet arranged on the pedal fixture. The measuring values of the Hall sensor can be telemetrically transferred to an evaluation station.

[0008] Although various devices are known, the known devices of the prior art fail to provide a solution for an applied-force sensing-device which can be added on to exercise apparatuses such as bicycle, without dismantling and/or replacing certain mechanisms, for example the bicycle gear system, pedals or the crank arm, or crank spider in a manner that allows precise measuring.

[0009] Exercise environments often introduce reaction forces such as vibration. In these environments, sensors must be installed

and anchored to firmly grip the measured object/part, for achieving precise measurements over time. For bicycle raiders in particular, to achieve and maintain precise measuring, installation of applied-force sensing-devices often requires the dismantling of mechanisms and replacing the original parts with specialized parts. These parts are often very expensive and usually require professional person expertise to install and maintain.

[0010] An applied force measuring arrangement is already known as Strain Gage, used to measure the strain forces applied to a surface or object. For example see Transducer-Class® Strain Gages, part number: S1425 or S120P, made by Full Bridge Patterns, Vishay Micro-Measurements. Strain force measuring requires the anchoring of the sensor to the measured surface for maximizing the direct transferring of forces. Furthermore, continuous pressure is also required, to maintain constant and firm contact between the strain sensor and the measured surface or object.

[0011] To date, there are no satisfactory add-on devices and methods for applied-force sensing-devices, which offer easy add-on installation to different types of exercise devices, do not require any action of dismantling any mechanisms and/or replacing any original parts, and maintain precise measurements in an exercising environment. Thus, there remains a need in the art for an improved add-on device and method.

[0012] In addition, there is an increasing commercial demand for personal training applications, such as smart phones application designed to work with different athletic exercise devices (for example see the Edge 800® and Edge 500®, made by GARMIN; Node 1 and Node 2, made by Bontrager Node computers). There is a need to provide a system and method for easy add-on attachment of applied-force measuring device, able to continuously measure precise forces and transmit them to an external device for processing and display, using for example, wireless protocols.

Summary of the Invention

[0013] It is hence one object of the invention to disclose a device for measuring a force applied to a bicycle pedal by a rider. The aforesaid device is attachable to a pedal crank. The device comprises the features of claim 1.

[0014] Another object of the invention is to disclose said spring-loaded leaf attached along a direction of bending deformation of said crank arm.

[0015] A further object of the invention is to disclose the spring-loaded leaf attached along a direction of twisting deformation of said crank arm and pedal.

[0016] A further object of the invention is to disclose the control unit further comprising at least one component selected from the group consisting of an amplifier, an analog-to-digital converter, a microprocessor, a wireless communication interface, display means and a data transponder.

[0017] A further object of the invention is to disclose at least one component connected to said control unit which is selected from the group consisting of a sensor of crank angular displacement, a temperature sensor and a pedal cadence sensor.

[0018] A further object of the invention is to disclose the control unit preprogrammed for auto-calibration.

[0019] A further object of the invention is to disclose a method of measuring a force applied to a bicyclical pedal by a rider. The aforesaid method comprises the steps according to claim 7.

[0020] A further object of the invention is to disclose the step of measuring said deformation comprising measuring bending deformation of said crank.

[0021] A further object of the invention is to disclose the step of measuring said deformation comprising measuring twisting deformation of said crank arm and pedal.

Brief description of the drawings

[0022] The subject matter regarded as the invention is particularly pointed out and distinctly claimed in the following portion of the description. The invention, however, both as to organization and method of operation, together with objects, features, and

advantages thereof, may best be understood by reference to the following description when read with the accompanying drawings in which:

FIGS. 1a and 1b illustrate the device, installed on a bicycle crank arms;

FIG. 2 presents front, rear, top and cross-sectional views of the device installed on the inner side of a bicycle crank arm;

FIGS. 3a and 3b illustrate a perspective view of the device installable onto a bicycle crank arm;

FIG. 4 illustrates the device, installed on a bicycle crank arm attached by a pedal;

FIGS 5a and 5b present views of the device installable onto a bicycle crank attached by a pedal;

FIG. 6 is an exploded view of the device, installed on a bicycle pedal; and

FIG. 7 is a schematic diagram of the main electronic components in the device, according to some embodiments of the present invention.

Description of the invention

[0023] In the following description, specific details are set forth in order to provide a thorough understanding of the invention. However, it will be understood by those skilled in the art that the present invention may be practiced without these specific details. In other instances, well-known methods, procedures and components have not been described in detail so as not to obscure the present invention.

[0024] The term "sensor" hereinafter refers to a pre-stressed leaf operatively connected to a strain gage. The aforesaid strain gage is configured for generation of an electric signal corresponding to a deformation of the pre-stressed leaf.

[0025] It should be emphasized that the claimed device of the present invention is designed for attaching to standard bicycle articles and no improvement or modification of the bicycle articles is needed.

[0026] According to some embodiments of the present invention, there is provided an applied-force sensing device, method and system for people who take interest in their performance during athletic activity, which device and/or method and/or system may be described in view of Figs. 1 - 7.

[0027] A primary function of the invention is to provide the means to improve the ease of installation of applied-force sensing-devices, while assuring continuous precise measurements over time in an exercise environment, by allowing users to tightly attach the device to a measured object in a manner which creates constant pressure, ensuring the consecutiveness of contact required for sensitive and precise measuring.

[0028] According to some embodiments of the present invention the device may be shaped as a case hosting electronic components (2) made of resilient material such as Metal or plastic shell.

[0029] According to the present invention, the device may include at least one applied-force sensor such as a strain-gage (5), cased in the shell (2) and provided with a spring loaded leaf (4) for measuring the force applied to an exercise object.

[0030] According to the present invention, a spring-loaded 'leaf' (4) is firmly connected to a measured object. Accordingly, the spring-loaded 'leaf' (4) may indicate the strain force applied to the object/part/crank arm/pedal (100), to be measured by the strain-sensor (5).

[0031] According to some embodiments of the present invention, the means (1) for attaching the device to the object/part, may allow the attachment of the device to the object/part/crank arm, by tightening the latch (1) which is wrapped around the object/part (100), using screw arrangement (6). Accordingly, tightening the wrapping latch around the object/part (100), presses the spring-loaded 'leaf' (4) against the object/part (100), applying constant force downward, thus maintaining constant tightened contact between the sensor (5) and the measured object/part (100).

[0032] According to some embodiments of the present invention, the attachment of the device may be done on different

positions on the exercise device/object, for example, on either side of the crank arm of a bicycle (see fig.1A and fig.1B). The above mentioned embodiment is configured for measuring elastic bending deformation of the crank arm.

[0033] In accordance with another embodiment of the present, the device is configured for measuring elastic twisting deformation of the crank arm and pedal as shown in FIG. 6. A twisting force is applied to a pedal 105 by a rider (not shown) and is transferred to the crank arm 100. The aforesaid force is applied along an arrow 102. The rider can press down onto the pedal 105 and pull it up when the rider's foot is fixedly attached to the pedal 105. The pedal 105 is connected to a threaded opening 115 in the crank arm 100. The spring-loaded member 10 is firmly connected to the crank arm 100 by the pedal 105. The strain gage 5 provides a change in electric impedance corresponding to deformation of the member 10. The aforesaid deformation corresponds to deformation in the crank arm 100 and the pedal 105.

[0034] According to some embodiments of the present invention, the device may include all or some of the following components (see fig.7): strain sensors (200); electronic sensor amplifier (201); pedal cadence sensor (202); temperature sensor (204); crank arm angular displacement sensor (205); A/D converter (206); a transmitting device (207); a microprocessor (208) and wireless communication means 209.

[0035] According to some embodiments of the present invention, the users may operate the system by pressing the calibration button arrangement (101) to calibrate the applied force measurement sensor before each exercise activity.

[0036] According to some embodiments of the present invention, the calibration process may be done automatically by calculation processes in the microprocessor (208), or by calculation processes in the external wireless device (203).

[0037] According to some embodiments of the present invention, the device may include a transmitting device (207) for transmitting the measured data to an external wireless device (203). Data may be transmitted using wireless protocols for example RF, Bluetooth.

[0038] In accordance with these and other objects, this invention provides a means structured to allow easy add-on attachment of the sensing device to the measured exercise object/part, to provide constant tightened contact between the sensing device and the measured object even under constant vibrations and to directly process and transmit the measured data to an external device, thus improving the integration and ease of use of exercise enhancing applications.

[0039] While certain features of the invention have been illustrated and described herein, many modifications, substitutions, changes, and equivalents will now occur to those skilled in the art, within the scope of the appended claims.

REFERENCES CITED IN THE DESCRIPTION

This list of references cited by the applicant is for the reader's convenience only. It does not form part of the European patent document. Even though great care has been taken in compiling the references, errors or omissions cannot be excluded and the EPO disclaims all liability in this regard.

Patent documents cited in the description

- [US7775128B2 \[0005\]](#)
- [US7806006B2 \[0005\]](#)
- [US7599806B2 \[0005\]](#)
- [US7257468B1 \[0005\]](#)
- [US6418797B1 \[0005\]](#)
- [US5758735A \[0005\]](#)
- [US5591903A \[0005\]](#)
- [US5257540A \[0005\]](#)
- [US5031455A \[0005\]](#)
- [US4423630A \[0005\]](#)
- [DE4227586 \[0006\]](#)
- [WO200220094A \[0007\]](#)

Patentkrav

1. Anordning til måling af en kraft, der er påført en cykelpedal (105) af en rytter; hvilken anordning kan fastgøres på en standard cykel-krumtaparm (100), der holder pedalen (105), som er fastgjort derpå; hvilken anordning omfatter:
- 5 a. et fastgørelsesmiddel (1), der er indrettet til at omfavne og løsgøres fra krumtaparmen (100);
- b. et fjederbelastet blad (4), der er fastgjort på krumtappen
- 10 (100);
- c. i det mindste en belastningsmåler (5), der er indrettet til at måle en belastning på bladet (4);
- d. en styreenhed;
- kendetegnet ved, at det fjederbelastede blad (4) presses mod
- 15 krumtaparmen (100) med fastgørelsesmidlet (1).
2. Anordning ifølge krav 1, hvor det fjederbelastede blad (4) er fastgjort langs en retning af bøjningsdeformation af krumtaparmen (100).
- 20
3. Anordning ifølge krav 1, hvor det fjederbelastede blad (4) er fastgjort langs en retning af vridningsdeformation af krumtaparmen (100) og en pedal (105).
- 25
4. Anordning ifølge krav 1, hvor styreenheden yderligere omfatter i det mindste en komponent, der er valgt fra gruppen bestående af en forstærker (201), en analog-digitalomformer, en mikroprocessor (208), et trådløst kommunikationsinterface (209), et displaymiddel og en datatransponder.
- 30
5. Anordning ifølge krav 4, hvor i det mindste en komponent, der er forbundet til styreenheden, er valgt fra gruppen bestående af en sensor til krumtap-vinkelforskydning, en temperatursensor (204) og en pedal-kadencesensor (202).
- 35
6. Anordning ifølge krav 1, hvor styreenheden er forprogrammeret til autokalibrering.

7. Fremgangsmåde til at måle en kraft, der er påført en cykelpedal (105) af en rytter; hvor fremgangsmåden omfatter trinene til:

5 a. at tilvejebringe en anordning til måling af en kraft, der er påført en cykelpedal (105) af en rytter; hvilken anordning kan fastgøres på en standard cykelkrumtaparm (100), der holder pedalen (105), som er fastgjort derpå; hvilken anordning omfatter:

10 i. fastgørelsesmiddel (1), der er indrettet til at omfavne og løsgøres fra krumtaparmen (100);

ii. et fjederbelastet blad (4);

iii. i det mindste en belastningsmåler (5), der er indrettet til at måle en belastning på bladet (4).

iv. en styreenhed;

15 b. at fastgøre anordningen til krumtaparmen (100);

c. at påføre et drejningsmoment på krumtaparmen (100) af rytteren;

d. elastisk deformation af krumtaparmen (100) med drejningsmomentet;

20 e. at måle deformationen ved hjælp af belastningssensoren (5); kendetegnet ved, at det fjederbelastede blad (4) presses mod krumtaparmen (100) med fastgørelsesmidlet (1).

25 8. Fremgangsmåde ifølge krav 7, hvor trinene til at måle deformationen omfatter at måle bøjningsdeformation af krumtaparmen (100).

9. Fremgangsmåde ifølge krav 7, hvor trinene til at måle deformationen omfatter at måle vridningsdeformation af 30 krumtaparmen (100) og pedalen (105).

10. Fremgangsmåde ifølge krav 7, hvor anordningen er tilvejebragt med en styreenhed, der yderligere omfatter i det mindste en komponent, der er valgt fra gruppen bestående af en 35 forstærker (201), en analog-digitalomformer, en mikroprocessor (208), et trådløst kommunikationsinterface (209), et displaymiddel og en datatransponder.

11. Fremgangsmåde ifølge krav 10, hvor i det mindste en komponent, der er forbundet til styreenheden, er valgt fra gruppen bestående af en sensor til krumtap-vinkelforskydning, en temperatursensor (204) og en pedal-kadencesensor (202).

5

12. Fremgangsmåde ifølge krav 7, hvor styreenheden er forprogrammeret til autokalibrering.

DRAWINGS

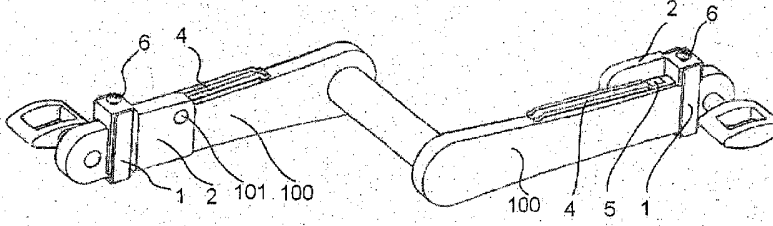

Fig. 1a

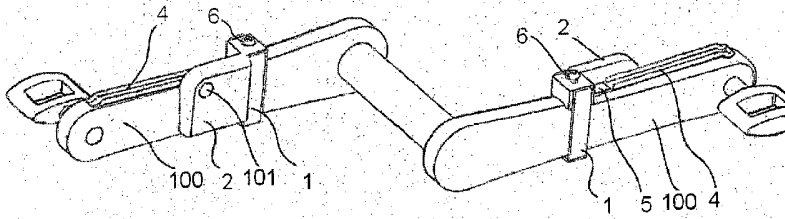

Fig. 1b

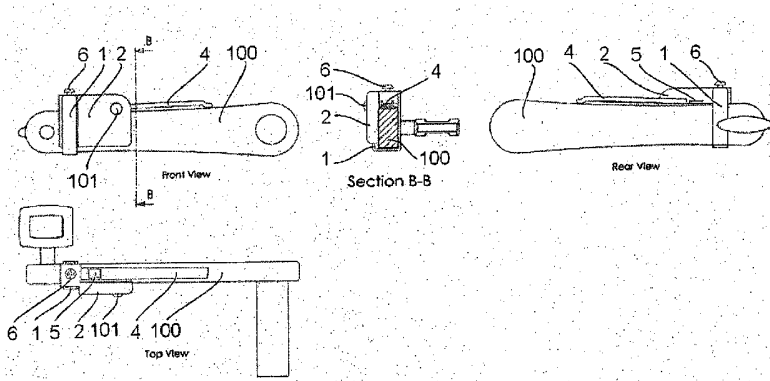

Fig. 2

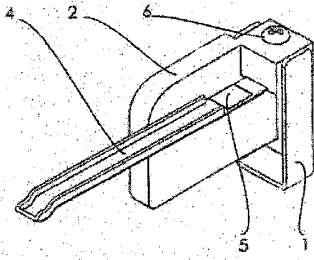

Fig. 3a

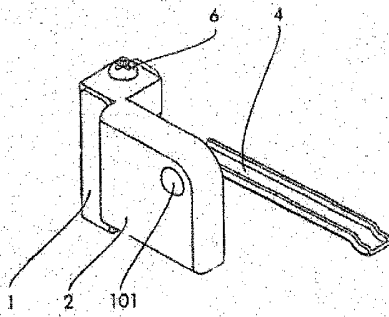

Fig. 3b

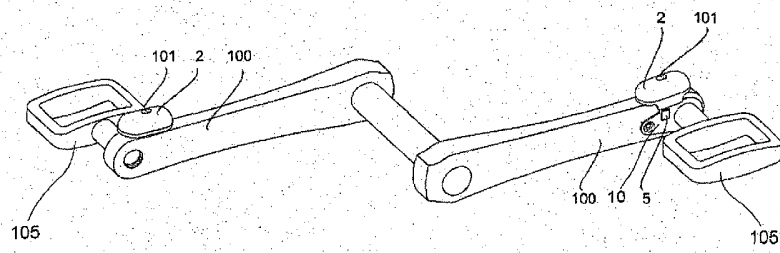

Fig. 4

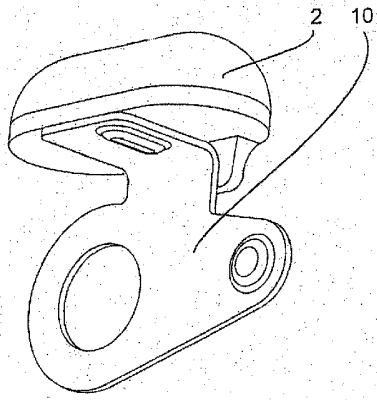

Fig. 5a

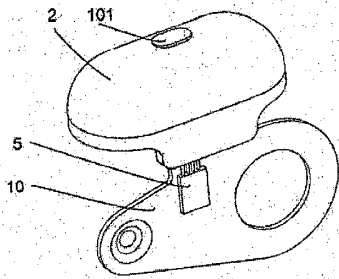

Fig. 5b

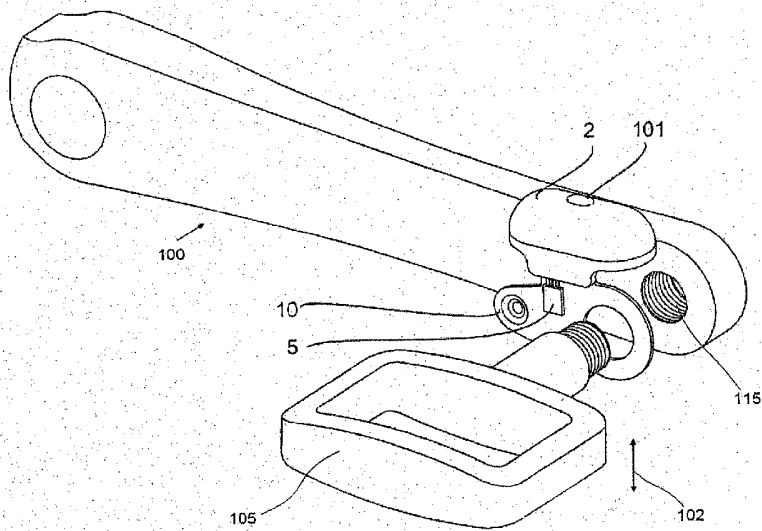

Fig. 6

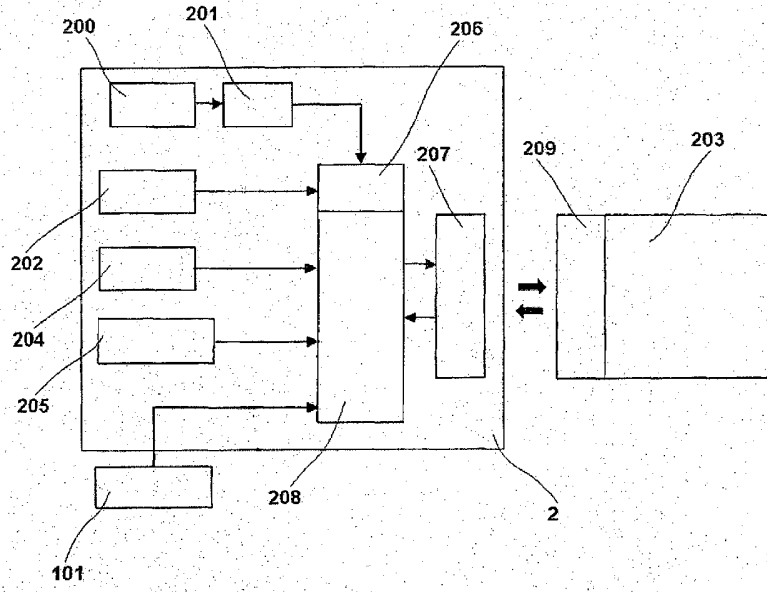

Fig. 7