

No. 885,306.

PATENTED APR. 21, 1908.

MATHIAS WESTENHAVER & MARSHALL WESTENHAVER.

DITCHING APPARATUS.

APPLICATION FILED AUG. 19, 1907.

4 SHEETS—SHEET 1.

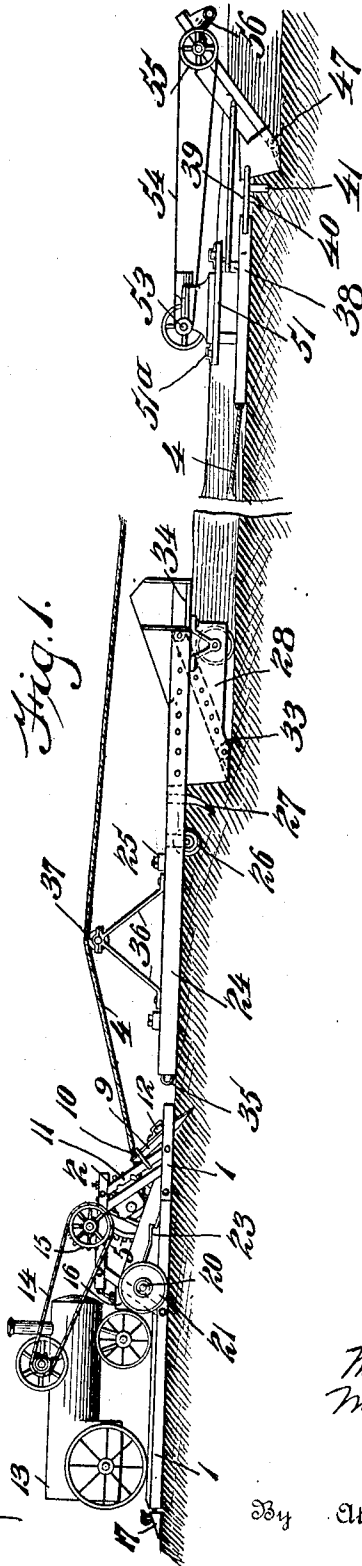

Witnesses:  
*H. E. Dieterich*  
*W. R. Bridger*

*Mathias Westenhaver*  
*Marshall Westenhaver*,  
Inventors,

By *Attorneys Davis & Davis*

No. 885,306.

PATENTED APR. 21, 1908.

MATHIAS WESTENHAVER & MARSHALL WESTENHAVER.

DITCHING APPARATUS.

APPLICATION FILED AUG. 19, 1907.

4 SHEETS—SHEET 2.

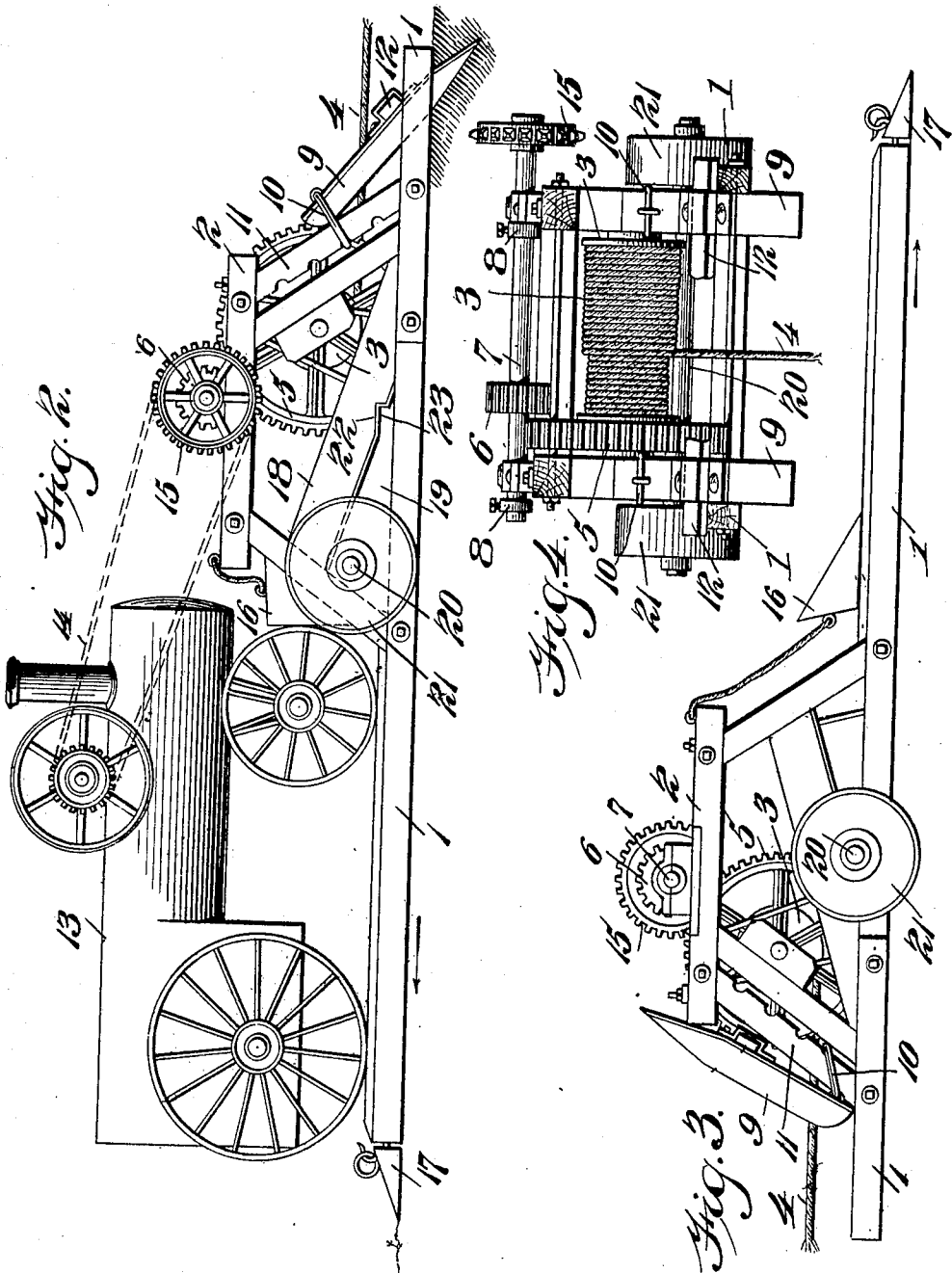

Witnesses:  
*H. S. Dieterich*  
*W. B. Bridge*

*Mathias Westenhaber*  
*Marshall Westenhaber*  
Inventors,

By *Davis & Davis*  
Attorneys

No. 885,306.

PATENTED APR. 21, 1908.

MATHIAS WESTENHAVER & MARSHALL WESTENHAVER.

DITCHING APPARATUS.

APPLICATION FILED AUG. 19, 1907.

4 SHEETS—SHEET 3.

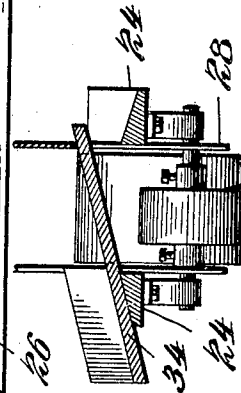
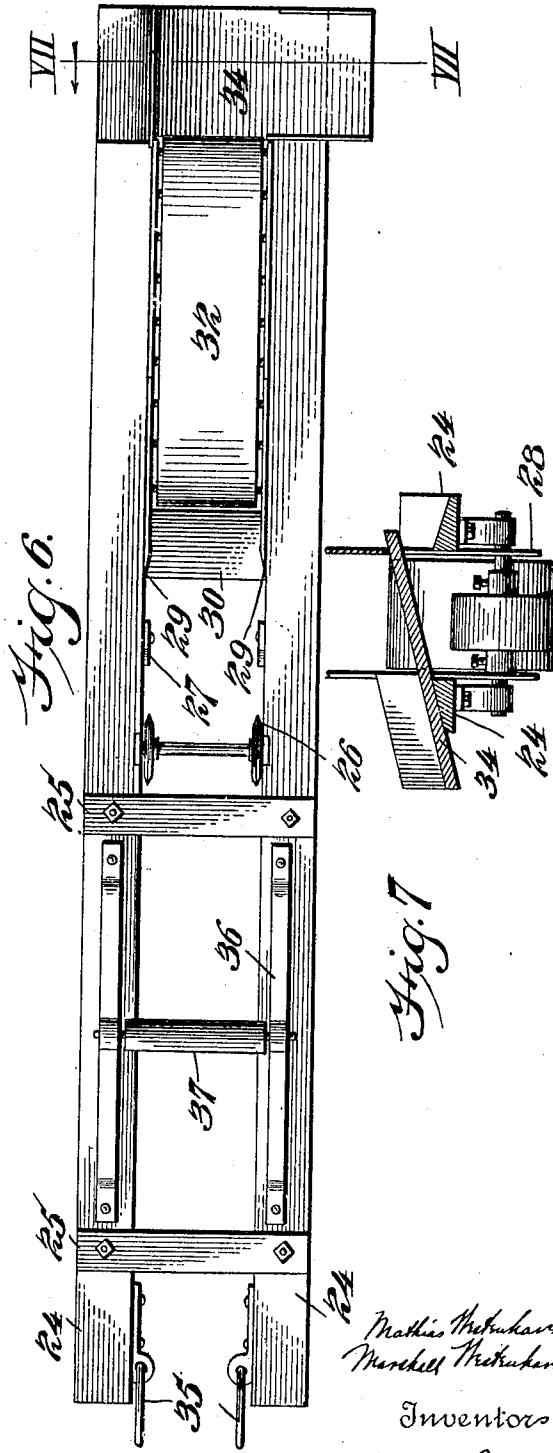
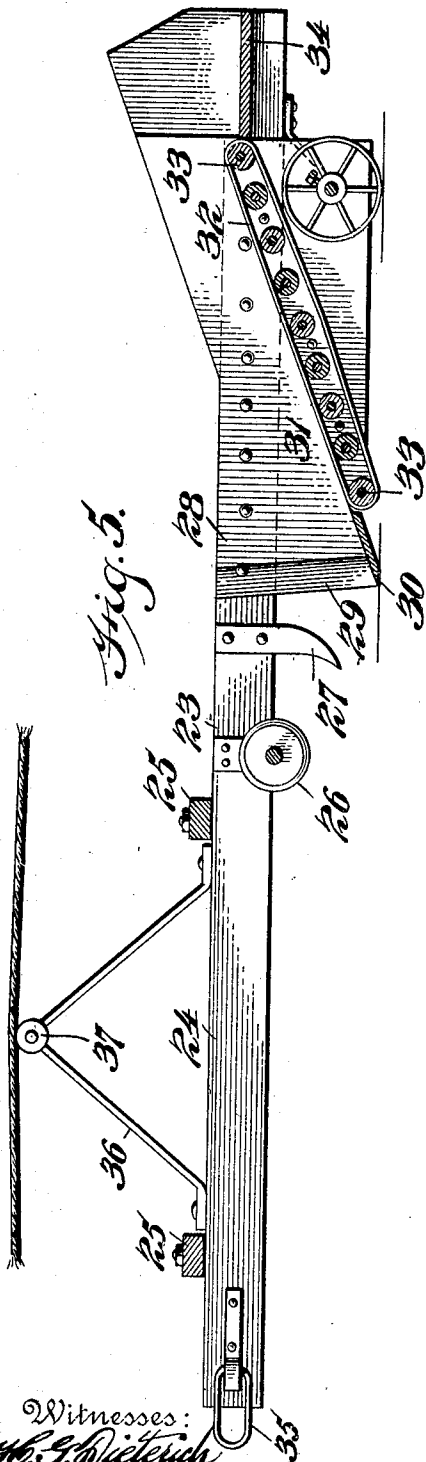

Witnesses:  
*H. S. Dietrich*  
*A. R. Bridges*

*Mathias Westenhaver*  
*Marshall Westenhaver*

Inventors

By *Davis & Davis*  
 Attorneys

No. 885,306.

PATENTED APR. 21, 1908.

MATHIAS WESTENHAVER & MARSHALL WESTENHAVER.

DITCHING APPARATUS.

APPLICATION FILED AUG. 19, 1907.

4 SHEETS—SHEET 4.

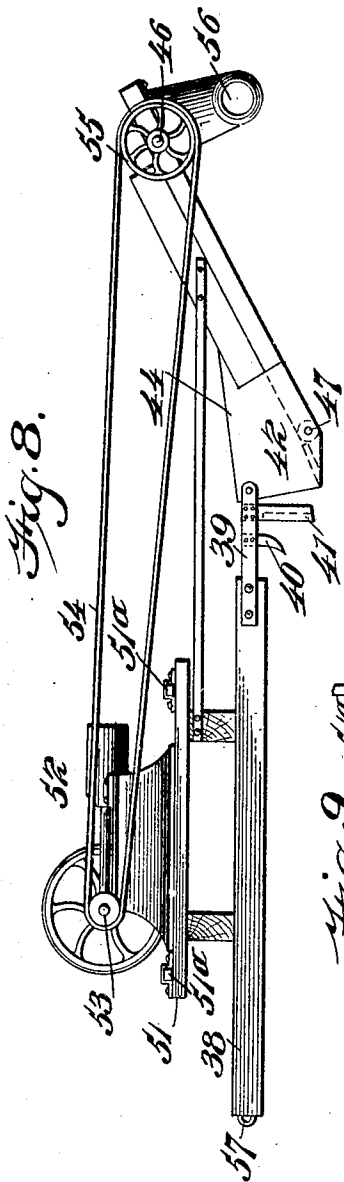

Fig. 8.

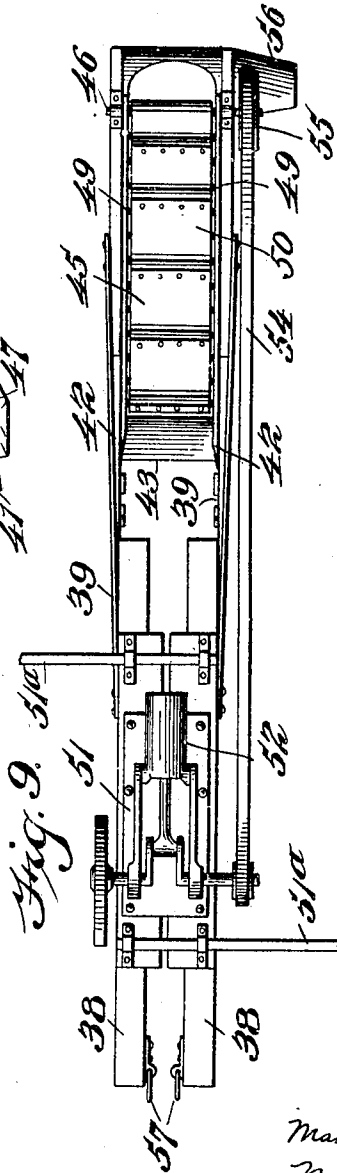

Fig. 9.



Fig. 10.



Fig. 11.

Mathias Westenhaver  
Marshall Westenhaver

Inventors,

By Attorneys Davis & Davis

Witnesses:  
H. G. Dieterich  
A. R. Bridge

# UNITED STATES PATENT OFFICE.

MATHIAS WESTENHAVER AND MARSHALL WESTENHAVER, OF STERLING, KANSAS.

## DITCHING APPARATUS.

No. 885,306.

Specification of Letters Patent.

Patented April 21, 1908.

Application filed August 19, 1907. Serial No. 389,266.

*To all whom it may concern:*

Be it known that we, MATHIAS WESTENHAVER and MARSHALL WESTENHAVER, of the city of Sterling, county of Rice, and State of Kansas, have invented certain new and useful Improvements in Ditching Apparatus, of which the following is a specification, reference being had therein to the accompanying drawings, in which—

10 Figure 1. is a side elevation of the apparatus complete; Fig. 2. a side elevation of the drum platform, and the motor thereon; Fig. 3. a similar view of the other side of the drum and motor platform; Fig. 4. a front elevation of said platform; Fig. 5. a longitudinal vertical sectional view of the primary ditching means; Fig. 6. a plan view of the primary ditching means; Fig. 7. a transverse vertical sectional view on the line VII—VII of Fig. 6; Fig. 8. a side elevation of the ditch finishing device. Fig. 9. a plan view thereof; Fig. 10 a vertical sectional view of the conveyer used in the ditch finishing machine; Fig. 11 a horizontal sectional view of the device for pressing the sides of the ditch.

25 One of the objects of this invention is to provide an apparatus for cutting long straight ditches by means of a primary ditching device and a ditch finishing device, these two devices being connected in turn to a hauling cable, said cable being connected to a suitable drum and means being provided to rotate said drum.

30 Another object of the invention is to provide a drum platform adapted to hold a suitable drum-driving motor, and being provided with means whereby the strain on the hauling cable will serve to drive an anchoring means into the ground.

40 A further object of the invention is to provide improved ditching devices, one of which is adapted to be used as a primary ditching means, and the other as a ditch-finishing means, the first device serving to cut a ditch in which the finishing device may be moved. The finishing device is adapted to be driven along the ditch made by the primary ditching means, and to cut said ditch deeper, and to smooth the sides thereof.

50 Referring to various parts by numerals 1 designates the base of the drum platform; 2 a drum supporting frame mounted on the rearward end thereof. In this frame is mounted the drum 3 on which the hauling cable 4 is wound. This drum is provided with a gear 5 which meshes with a pinion 6

mounted on a drive shaft 7. This drive shaft is slidably mounted in its bearings to engage and disengage the pinion 6 and the gear 5. The shaft 7 is provided with adjustable collars 8 which are adapted to hold the shaft in its adjusted positions.

60 The rearward end of the drum platform is provided with a pair of anchor stakes 9 each of which is provided with a keeper 10 pivotally secured to its upper end. The keepers 10 engage the notched bars 11, and thereby hold the upper ends of the anchor stakes when a rearward pulling strain is brought on the cable 4. The lower ends of the anchor stakes project below the base of the drum platform and into the ground, as indicated in Fig. 2. to hold said platform in position. These stakes are prevented from entering too far into the ground by a cross bar 12 removably mounted in keepers secured to the upper sides of said stakes, the projecting ends of said bar engaging the upper surface of the base of the drum platform, as shown clearly in Fig. 2. When the drum platform is being transported, the anchor stakes are withdrawn from the ground and turned back and upward, as shown in Fig. 3. In this position the bar 12 is usually withdrawn from its keepers so that it will not interfere with the hauling cable.

75 The drum platform is adapted to support the motor 13, which as shown in Figs. 1 and 2 of the drawings, is a traction engine. A chain belt 14 connects said engine with the sprocket wheel 15 mounted on the drive shaft. On the front inclined side of the drum supporting frame is mounted a gravitating tension block 16, which engages the forward wheels of the engine and serves to hold said engine away from the drum supporting frame, and to maintain a tension on the drive chain 14. In order to facilitate the placing of the engine on the platform a detachable board is provided which may be connected to the front end of the platform, and whose upper surface is inclined to facilitate the movement of the engine up to the platform or down from it. When transporting the drum platform this board may be removed if desired.

100 The frame supporting the drum is provided with a forwardly and upwardly inclined bar 18, which together with the other bars of the drum-supporting frame form the triangular opening 19. Extending across the machine through these openings 19 is a shaft 20, to

the ends of which are secured the transporting wheels 21. The openings 19 are of such height at their front ends that the shaft 20 may free itself from the walls thereof and permit the drum platform to rest on the ground, the shaft 20 being thereby relieved of all weight. If it is desired to move the platform the shaft 20 is forced to the rear ends of the openings 19. This lifts the rear end of the platform and permits the shaft 20 to enter notches 23 formed in the under sides of the bars 18 near the rear ends of the openings 19. In this position the shaft 20 supports the drum platform and permits it to be readily transported. When it is desired to transport the platform the hauling cable is attached to the front thereof, and by drawing it forward the lower inclined sides of the bars 18 ride up over the shaft 20 until said shaft drops into the notches 23. It will also be seen that by drawing the platform forward the anchor stakes will be withdrawn from the ground.

The primary ditching means consists of a frame formed of two long longitudinal beams 24. These beams are parallel and are spaced apart a distance equal to the width of the ditch to be cut, the cutting devices being carried between said beams. The beams are connected together by cross bars 25, and they carry, about midway their ends, the rotary disk cutters 26. These cutters are arranged close to the inner sides of the beams and serve to cut through the upper surface of the ground and to mark the side lines of the ditch. These cutters extend a suitable distance below the lower surfaces of the beams in order to make a cut of the desired depth. To the rear of these disk cutters, are rigidly mounted cutting blades or plows 27. These blades are secured to the inner sides of the beams and extend below the disk cutters. As they travel directly in the rear of the disk cutters they will serve to increase the depth of the cut made by the said disks.

In the rear of the blade cutters is mounted the ditching cutter 28 which is formed with vertical cutters 29 and the lower horizontal cutter 30 which connects the lower ends of the cutters 29. The cutters 29 incline rearwardly and travel directly in the rear of the blade cutters 27. These cutters are deeper than cutters 27 and serve to deepen the cut made by them. The lower cutter 30 cuts under the soil that is to be removed, said soil passing rearwardly and upwardly to the conveyer 31 mounted between the sides of the cutter 28. This conveyer extends upwardly and rearwardly from the rear end of the cutter 30 to the rear end of the frame; and it consists of an endless belt 32 mounted on and supported by suitable transverse rollers 33. The pressure of the earth that is being removed by the cutter 30 as the ditching device is moving, forces the dirt up the con-

veyer. From the conveyer it is delivered into a transverse chute 34 which rests upon the rear ends of the beams 24 and is inclined to discharge the earth at one side of the ditch. This chute may be arranged to discharge the dirt at either side of the machine, the rear ends of the beams being properly cut out to permit this to be done.

Connected to the forward ends of the beams 24 are loops 35 to which the hauling cable may be attached. To the upper sides of the beams, near their forward ends, uprights 36 are secured, said upright carrying a transverse roller 37. This roller serves to support the hauling cable when said cable is passed rearward over the primary ditching device and is connected to the ditch finishing device.

The ditch finishing device consists of a main platform formed of two longitudinal beams 38 which are parallel with each other, and are suitably connected together to form a narrow frame adapted to be moved along the ditch formed by the primary ditching means. Extending rearward from the rear ends of these beams are cutter-supporting bars 39 each of which carries a depending cutting blade 40 which extends below the bottom of the beams 38. To the rear of these blades 40 are cutting devices 41 which are provided with outwardly extending finishing blades 42<sup>x</sup> designed to press against the sides of the ditch, and to slightly compress and strengthen them. These cutting and finishing blades extend below the cutting blades 40, and practically to the bottom of the ditch to be cut. Secured to the rear ends of the bars 39 are the ditch cutters 42 which are connected at their lower ends by a horizontal cutter 43. The cutters 42 form the forward edge of the conveyer support 44 which extends rearwardly and upwardly and carries an endless conveyer 45. This conveyer is formed of two sprocket chains which travel over suitable sprocket wheels mounted on shafts 46 and 47 and are connected together by T-irons 48. These chains are supported on transverse rollers 49. Secured to each T-iron is a broad plate 50, said plate being secured to one T-iron along its rear edge, its forward edge resting loosely on the adjoining T-iron as shown in Fig. 10. By means of this construction the plates will serve to carry the dirt upward to the discharging point, and will then readily turn and pass downward to the cutter. This gives a flexibility to the chains combined with a large carrying capacity.

The main platform 38 supports a supplementary platform 51 at a suitable distance above the main platform and on a level with the surface of the ground in which the ditch is being cut. On this platform are arranged two outwardly extending bars 51<sup>a</sup> which project over the surface of the ground, and hold the ditching device substantially level in the

ditch. One of these bars projects out on one side of the ditch near the forward end of the frame, and the other extends out on the other side at the rear end of the frame. Mounted on this supplemental platform is a gas or gasolene engine 52 whose drive shaft 53 is connected by a drive chain 54 to a sprocket wheel 55 on the conveyer shaft 46. By this means the conveyer will be driven by the engine and the hauling mechanism will be relieved of the strain of forcing the material up the conveyer. The conveyer frame is formed at its upper rear end with a discharge chute 56 through which the material is discharged to the side of the ditch. To the forward ends of the beams 38 are secured loops 57 to which the cable 4 is to be attached. This finishing device is drawn through the ditch following the primary ditching device and serves to deepen the ditch, and at the same time to compress the sides thereof, as hereinbefore described.

Having thus fully described our invention what we claim, and desire to secure by Letters Patent is:

1. A ditching apparatus comprising a drum platform, a motor and drum thereon, means for anchoring the platform, means for connecting the motor to the drum, a primary ditching device, a cable adapted to be wound on the drum, means connecting said cable to the primary ditching device, means carried by the primary ditching device for cutting a shallow ditch and depositing the earth at one side of said ditch, a ditch finishing device adapted to be moved longitudinally in the ditch cut by the first device and carrying means to deepen the ditch and to compact the sides thereof, means carried by said finishing device to discharge the earth at one side of the ditch, means for attaching the cable to the ditch finishing device, and means carried by the primary ditching device to support the cable when the ditch finishing device is in operation.

2. In a machine of the class set forth, a portable frame carrying a motor and a drum and means for operating this drum, and an anchoring means, said means consisting of a pair of inclined beams on the frame notched at their rear edges, a loop engaging each one of these beams, a sharpened stake pivotally connected at its upper end to each one of these loops, and a removable cross-bar connecting said stakes.

3. In an apparatus of the class set forth, the combination of a portable frame, a motor, a drum and means for operating it from the motor, and an anchoring means consisting of a pair of stakes sharpened at their lower ends and having a loop connected to its upper end, said loop adjustably engaging one of the uprights of the frame, for the purpose set forth.

4. A ditching apparatus comprising a

drum platform, a drum thereon, a motor connected to said drum, a primary ditching device, a cable adapted to be wound on the drum, means to connect said cable to the ditching device, a ditch finishing device adapted to be moved longitudinally in the ditch cut by the first device, means whereby the cable may be attached to the said finishing device.

5. A ditching apparatus comprising a frame, a drum thereon and a motor to drive said drum, an anchoring means for the frame, a cable adapted to be wound on said drum, and two independent ditching devices adapted to be independently attached to said cable and be independently drawn in succession by the cable toward the frame, the second one being drawn in the ditch cut by the first one.

6. A ditching apparatus comprising a drum platform carrying a drum, a traction engine on said platform, a drive chain connecting said engine to the drum, gravitating stop blocks adapted to engage the wheels of the traction engine to maintain a tension on the drive chain, a ditching means, and a cable on the drum adapted to be connected to the ditching means to haul said means toward the drum.

7. A ditching apparatus comprising a drum platform, a drum thereon, a pair of transporting wheels, an axle connecting said wheels said axle passing through openings in the drum supporting frame, said openings being higher at their forward ends than at their rear ends whereby when the axle is at the forward ends of said openings the platform will rest on the ground, and when it is at the rear ends of said openings the platform will be supported by said axle above the ground, a cable on said drum, a ditching means and means for connecting said cable to the ditching means whereby the said means may be drawn towards the drum.

8. A ditching apparatus comprising a drum platform, a drum thereon, a motor connected to said drum, a cable on said drum, a ditching device consisting of a main frame carrying a series of cutters operating at different depths below said frame, an upwardly and rearwardly extending conveyer receiving the dirt from the lower most cutter and delivering it at one side of the ditch, a transporting wheel carried by the main frame at the rear end thereof and adapted to travel in the ditch cut by the device, and means for connecting the cable to the forward end of the ditching device.

9. A primary ditch cutting device consisting of two parallel longitudinal beams rigidly connected together a suitable distance apart, a pair of disk cutters secured to the sides of said beams and extending slightly below them, a pair of plows connected to the side of said beams in the rear of the disk cutters and extending below said cutters, and a

ditch cutter connected to the sides of said beams in the rear of the plows and extending below them, an upwardly and rearwardly inclined endless conveyer extending from the bottom of the ditch cutter to the top of the frame, a transverse chute carried by the frame at the rear thereof and adapted to receive the material from the conveyer and to discharge it at one side of the ditch, and a transporting wheel carried by the frame and adapted to travel in the ditch in the rear of the conveyer.

10. A ditch finishing device consisting of a frame formed of two longitudinal beams connected together, a pair of plows or cutters carried by said frame at the rear end thereof and extending below said frame, a pair of cutting and pressing devices carried by said frame in the rear of the plows and extending below said plows, said devices being adapted to impact the lower part of the walls of the ditch a ditch cutter carried by said frame in the rear of the pressing devices, an upwardly and rearwardly inclined conveyer carried by the frame and extending upward from the rear edge of the ditch cutter, a supplemental platform carried by the main frame, a gasoline engine mounted on said platform, and means connecting said engine to the conveyer.

11. A ditching apparatus comprising a drum platform, a drum thereon, a motor connected to said drum, a primary ditching means, a cable on said drum and adapted to be connected to the primary ditching means to haul said means toward the drum, and a ditch finishing device consisting of a frame formed of two longitudinal beams connected together, a pair of plows or cutters carried by said frame at its rear end and extending below said frame, a pair of cutters and pressing devices carried by said frame in the rear of the plows and extending below said plows, and serving to impact the lower part of the walls of the ditch, and a ditch cutter carried by said frame in the rear of the pressing devices, an upwardly and rearwardly inclined conveyer carried by the frame, and extending upward from the rear edge of the ditch cutter, a supplemental platform carried by the main frame, a gasoline engine mounted on said platform, and means connecting said engine to the conveyer.

12. A ditching apparatus comprising a drum platform, a drum thereon, a motor connected to said drum, a primary ditching means, a cable on said drum and adapted to be connected to the primary ditching means to haul said means toward the drum, said primary ditching means consisting of parallel longitudinal beams rigidly connected together, a pair of disk cutters secured to the

sides of said beams and extending slightly below them, a pair of plows in the rear of the disk cutters, and a ditch cutter connected to the sides of said beams and extending below the plows, an upwardly and rearwardly inclined endless conveyer extending from the bottom of the ditch cutter to the top of the frame, a transverse chute carried by the frame at the rear thereof and adapted to receive the material from the conveyer and to discharge it at one side of the ditch, and a transporting wheel carried by the frame and adapted to travel in the ditch in the rear of the conveyer.

13. A ditching apparatus comprising a frame, a drum thereon and a motor to drive said drum, an anchoring means for the frame, a cable adapted to be wound on said drum and two independent ditching devices adapted to be independently attached to said cable and be independently drawn in succession by the cable toward the frame, the second one being drawn in the ditch cut by the first one, said first or primary ditching device being provided with means for supporting and guiding the cable while it is drawing the second ditching device.

14. In a ditching machine of the class set forth, a portable platform carrying a drum and cable means at one end, a traction engine mounted removably on the other end of the platform, and detachable driving means between the traction engine and the drum mechanism, whereby the traction engine may be run off the platform and employed to drag the same along the ground.

15. In a ditching machine of the class set forth, a portable platform carrying a drum and cable means at one end, a traction engine mounted removably on the other end of the platform, and detachable driving means between the traction engine and the drum mechanism whereby the traction engine may be run off the platform and employed to drag the same along the ground.

16. In a ditching machine, a portable frame carrying a drum and operating mechanism therefor, a pair of transporting wheels and means on the frame whereby when the frame is dragged forwardly it will be raised from the ground and supported by said wheels during transportation, for the purpose set forth.

In testimony whereof we hereunto affix our signatures in the presence of two witnesses this 12 day of August 1907.

MATHIAS WESTENHAVER.  
MARSHALL WESTENHAVER.

Witnesses:  
R. M. BURRETT,  
JOHN J. SMITH, Jr.