

H. B. WEAVER.

Iron Planer.

No. 101,550.

Patented April 5, 1870.

Fig. 1

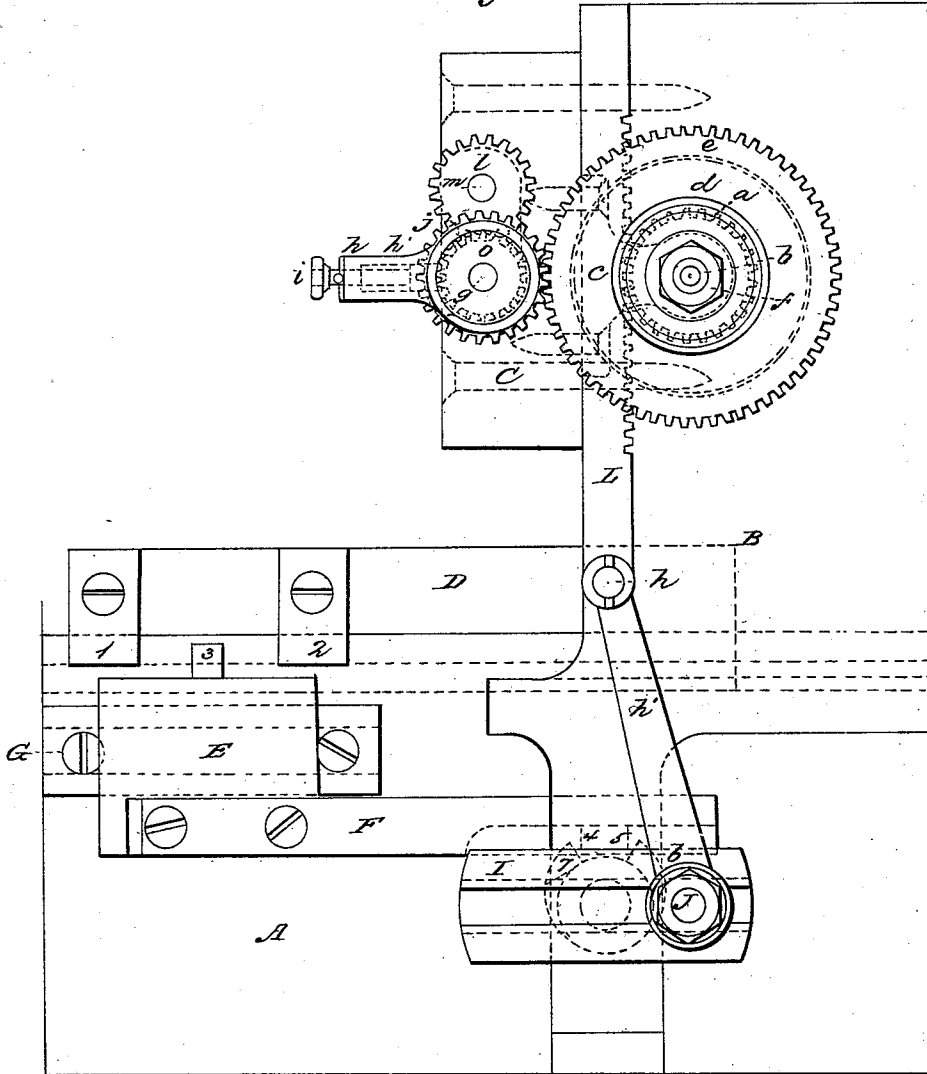

Witnesses:
Enos H. Lane
Alet Allen

Inventor:
Hiram B. Weaver

H. B. WEAVER.

Iron Planer.

No. 101,550.

Patented April 5, 1870.

Fig. 2

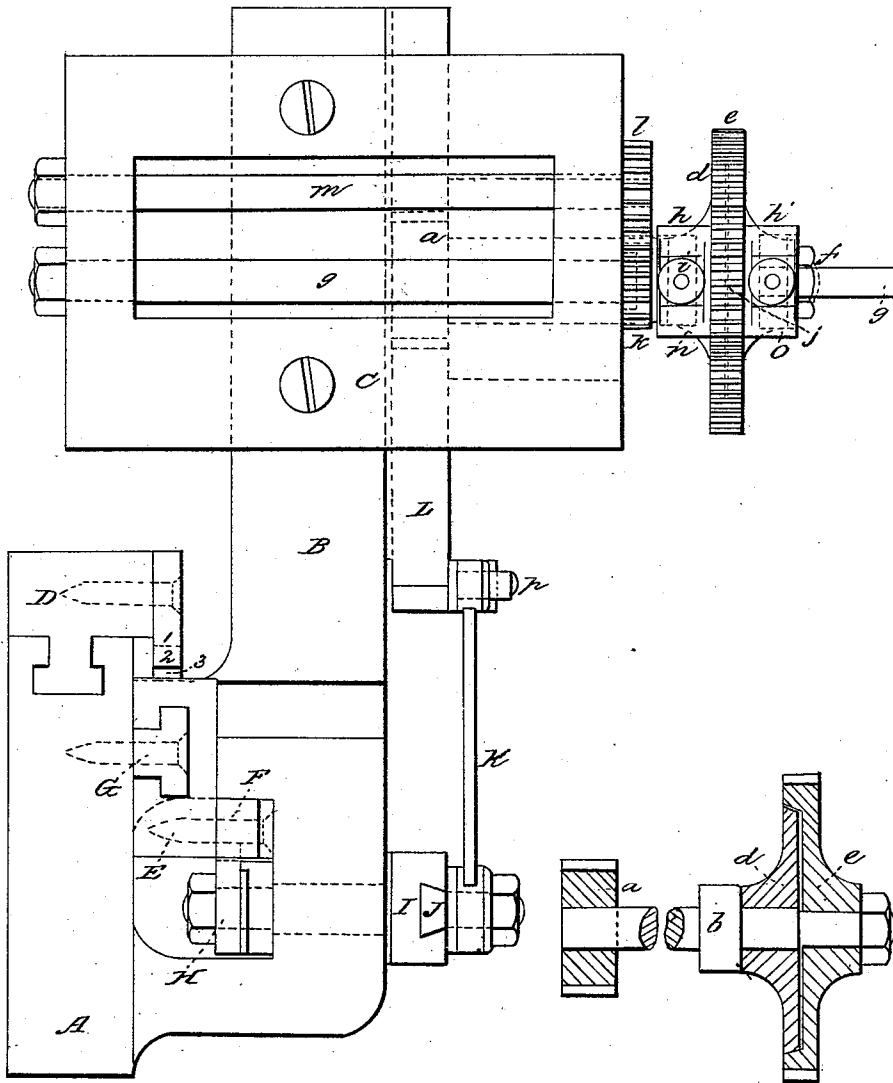

Witnesses:
Ernst H. Lane
Alex Allen

Inventor:
Hector B. Weaver

H. B. WEAVER,
Iron Planer.

3 Sheets—Sheet 3.

No. 101,550.

Patented April 5, 1870.

Fig. 3

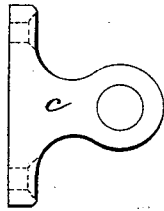

Fig. 4

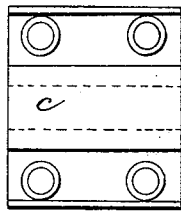

Fig. 5

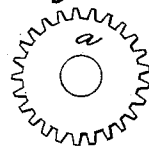

Fig. 6



Fig. 7

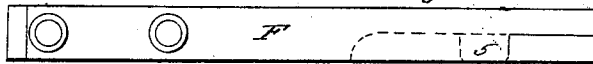

Fig. 8.

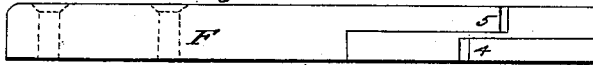

Fig. 9

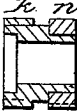
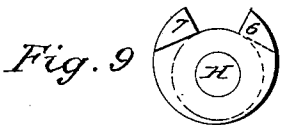

Fig. 13

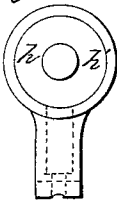

Fig. 14



Fig. 15 Fig. 16



Witnesses:
Emos H. Lane
Alex Allen

Inventor:
Horatio B. Weaver

United States Patent Office.

HORATIO B. WEAVER, OF HARTFORD, CONNECTICUT, ASSIGNOR TO GEORGE S. LINCOLN AND CHARLES L. LINCOLN, OF SAME PLACE.

Letters Patent No. 101,550, dated April 5, 1870.

IMPROVED FEED FOR IRON-PLANERS.

The Schedule referred to in these Letters Patent and making part of the same.

To all whom it may concern:

Be it known that I, HORATIO B. WEAVER, of Hartford, in the county of Hartford, in the State of Connecticut, have invented a new and improved Feed-Motion for Iron-Planers, in connection with the belt-shipping device; and I do hereby declare the following to be a clear and exact description thereof, and sufficient to enable others skilled in the art to which my invention appertains to fully understand and use the same, reference being had to the accompanying drawings making part of this specification, in which—

Figure 1 is an elevation of such parts of an iron planer as are embraced in my invention.

Figure 2 is an end view of the same parts as fig. 1.

Figures 3 and 4 are two views of the stand C, shown by dotted lines in both figs. 1 and 2.

Figures 5 and 6 are two views of the pinion-gear *a*, shown by dotted lines in both figs. 1 and 2.

Figures 7 and 8 are two views of the arm F.

Figures 9 and 10 are two views of the peculiar-shaped cam H.

Figure 11 is a view of gear *k*.

Figure 12 is a sectional view of gear *k*, and also a section of dog-wheel *n* attached.

Figure 13 is a view of the peculiar-shaped and recessed pieces *h* and *h'*.

Figure 14 is a sectional view of the pieces *h* and *h'*.

Figures 15 and 16 are two views of the dogs *i* and *i'*.

Figure 17 is a view of shaft *b*, pinion-gear *a*, flanch *d*, and gear *e*, in section.

The same letters and numerals designate the same parts in both views.

My invention relates to an improvement in the feeding-mechanism of iron-planers, and is designed to more effectually insure certainty of operation and uniformity of feed in the cutting-tool.

A represents the bed or frame of an iron-planer.

B represents the upright stand, or one of them, to which the cross-head is attached, and by which the cross-head is supported.

C represents the cross-head of an iron-planer.

D represents the table or platen of an iron-planer.

E is the sliding-piece that operates the feeding-mechanism, through the medium of the arm F.

F is the arm that operates the cam H.

G is a stationary piece of a T-shape, and it is firmly attached to the bed or frame.

H is a peculiar-shaped cam, attached to the end of the rocker I.

J is a stud-bolt, and

K is a connection between rocker I and rack L, through the medium of the stud *p*.

L is a rack, by means of which a reciprocating rotary motion is given to the feeding-mechanism.

a is a pinion-gear, attached to the end of shaft *b*, and is shown by dotted lines in both figures.

b is a shaft fitted into the stand *c*.

c is a stand attached to the back of the cross-head C, and is shown by dotted lines in both figures.

d is a flanch attached firmly to shaft *b*.

e is a gear fitted loosely on shaft *b*, and is recessed on one side sufficient to receive and cover flanch *d*.

Gear *e* is held in its place by the screw-nut *f*.

g represents the feed-screw in the cross-head of an iron-planer.

h and *h'* are two peculiar-shaped and recessed pieces, that carry the operating feed-dogs *i* and *i'*, and are both of them firmly attached to the pinion *j*.

k and *l* are spur-gears. *k* is fitted loosely on screw *g*, and *l* is firmly attached to one end of rod *m*.

m represents the feed-rod for operating the vertical feed of an iron-planer.

n and *o* are toothed dog-wheels, for the dogs *i* and *i'* to act upon.

dog-wheel *n* is attached to the gear *k*, and serves the purpose of operating the vertical feed of a planer, by means of the gears *k* and *l* and the rod *m*.

dog-wheel *o* is securely attached to the screw *g*, and serves the purpose of operating the cross or horizontal feed of an iron-planer, by means of the dog *i*.

It will be seen by referring to the drawing that the parts *h* and *h'* are each of them deeply recessed upon one side, and inclose in the recesses above referred to, the dog-wheels *n* and *o*.

By further observing the drawing, it will be seen that there is a pin in the stem of the dogs *i* and *i'*, resting in a receptacle provided in one end of each of the pieces *h* and *h'*.

The object and purpose of this pin is to hold the dogs *i* and *i'* in any desired position, whether that position be in contact with either dog-wheel or disengaged from either.

The numerals 1, 2, and 3, not before referred to, represent certain parts, as follows:

1 and 2 are movable stops, attached to the edge of a table or platen of an iron-planer.

3 is a stationary stop, attached to the sliding piece E, and serves to operate the whole of the above combination, when acted upon by the movable stops 1 and 2.

Having referred to all of the essential parts of my invention, I will describe its operation.

The table or platen being operated in any manner, causes the movable stop 1 to engage the fixed stop 3, carrying the sliding piece E with it sufficiently far to operate the belt-shipping device, (not shown,) thus causing the table or platen to move in the opposite direction, (by suitable gearing,) and as a consequence, carrying the sliding piece E with it, by means of the movable stop 2 engaging fixed stop 3.

This alternate reciprocating motion of the sliding piece E causes the arm F to engage one of the points

of the cam H, marked in the drawings 4 and 5 on the arm, and 6 and 7 on the cam H.

To be more definite, the first-described movement of the table causes the point 5 on the arm F to engage with the point 6 on the cam H, rotating it in the same direction that the arm F is moving, and as a consequence of this the rocker I is depressed at one end of its arm, carrying the connection K down, and with it the rack L, by means of the stud *p*, thus causing the pinion-gear *a* to revolve partially, carrying gear *e*, with the pinion *j*, with it.

Now, as both the pieces *h* and *h'* are firmly attached to pinion *j*, any movement of *j* carries *h* and *h'* with it; consequently, if either of the dogs *i* or *i'* are in contact with its appropriate dog-wheel, that feed, be it either vertical or horizontal, is operated by the medium of the screw *g* and dog-wheel *o*, in the case of the horizontal feed at *g'* is attached to the tool-holder of a planer in the usual manner, or through the medium of the gears *k* and *l* and the rod *m*, in the case

of the vertical feed insuring a certain and uniform action of the cutting-tool.

What I claim as my invention, and desire to secure by Letters Patent, is—

1. The combination of the peculiar-shaped and recessed pieces or dog-holders *h* and *h'*, dogs *i* and *i'*, and dog-wheels *n* and *o*, with the pinions *j*, *k*, and *l*, and the shafts *m* and *g*, as and for the purpose set forth.

2. The combination of the arm F, cam H, rocker I, connection K, rack L, pinion-gear *a*, shaft *b*, stand *c*, flanch *d*, gear *e*, pinion *j*, together with the peculiar-shaped pieces *h* and *h'*, the dogs *i* and *i'*, and dog-wheels *n* and *o*, the whole operating together, as and for the purpose herein set forth.

HORATIO B. WEAVER.

Witnesses:

ENOS H. LANE,
ALEX. ALLEN.