

(19) **DANMARK**

(10) **DK/EP 1709416 T3**



(12) **Oversættelse af
europæisk patentskrift**

Patent- og
Varemærkestyrelsen

-
- (51) Int.Cl.: **G 01 M 11/08 (2006.01)** **G 01 B 11/16 (2006.01)** **G 01 L 1/24 (2006.01)**
- (45) Oversættelsen bekendtgjort den: **2018-06-18**
- (80) Dato for Den Europæiske Patentmyndigheds bekendtgørelse om meddelelse af patentet: **2018-03-07**
- (86) Europæisk ansøgning nr.: **05700581.1**
- (86) Europæisk indleveringsdag: **2005-01-20**
- (87) Den europæiske ansøgnings publiceringsdag: **2006-10-11**
- (86) International ansøgning nr.: **DK2005000031**
- (87) Internationalt publikationsnr.: **WO2005071382**
- (30) Prioritet: **2004-01-23 DK 200400093**
- (84) Designerede stater: **AT BE BG CH CY CZ DE DK EE ES FI FR GB GR HU IE IS IT LI LT LU MC NL PL PT RO SE SI SK TR**
- (73) Patenthaver: **LM Wind Power International Technology II ApS, Jupitervej 6, 6000 Kolding, Danmark**
- (72) Opfinder: **MORTENSEN, Ivan, Engmark, Gl.Tved 6, Tved, 6000 Kolding, Danmark**
SVENDSEN, Tage, Egholtvej 3, Andst, 6600 Vejen, Danmark
GALLON, Andrew, Munro, 29 Newtown Road, Woolston, Southampton SO19 9HX, Storbritannien
- (54) Benævnelse: **Indretning omfattende et system indrettet til anvendelse i temperaturkompensation for belastningsmålinger i fiberforstærkede strukturer**
- (56) Fremdragne publikationer:
EP-A- 0 892 244
WO-A-97/15805
WO-A1-03/076887
US-A- 5 094 527
US-A- 5 196 694
US-A- 5 649 035
US-A- 5 887 107

DESCRIPTION

[0001] The present invention relates to a device comprising a fibre-reinforced part and including at least one system adapted for use in temperature compensation of strain measurements, said system comprising at least one optical fibre as well as connecting means adapted for connection of light emitting means and light receiving means to the optical fibre, said optical fibre comprising a number of reflecting structures. The invention further relates to a method of manufacturing a device as well as to connecting means and holding means.

Different types of devices for use when measuring strain in structural elements are known, e. g. foils provided with a metallic layer forming a predetermined path adapted for electrical measurement and optical fibres provided with Bragg gratings for optical measurement. The latter being a strain sensor comprising an optical waveguide having a plurality of reflecting structures, so-called Bragg gratings, along its length. Such devices are commonly denominated "strain gauges" and are provided on structures to measure actual strain in the structure. In case the strain gauge is subject to a change in temperature, this will affect the measurement due to natural elongation or contraction. To have an accurate measurement it is therefore necessary to compensate the strain measurement with respect to change of temperature.

Various methods have been used to provide compensation for temperature change, but none suitable for fibre-reinforced parts.

PCT application publication number WO 03/076887 describes a strain isolation element suitable for applying to a surface.

One object of the invention is to provide means suitable for use in providing compensation for temperature change in strain measurement, which may be built into a fibre-reinforced part of a device. Another object is to provide a method of manufacturing such a device where said means are built into a fibre-reinforced part.

[0002] New features of a device according to the invention involve that the system comprises at least one holding means adapted to hold one or more loops formed on the optical fibre, in a way where at least one loop may substantially freely change length when subject to a change in temperature, and where the at least one optical fibre is at least extending between the connecting means and the holding means, and where said at least one loop, which may substantially freely change length, is held by the holding means and comprises a part of the optical fibre, which comprises a number of reflecting structures, and where said optical fibre, the connecting means and the holding means are at least partly embedded in said fibre-reinforced part of said device.

[0003] When the holding means are adapted to hold one or more loops formed on the optical fibre, in a way where at least one loop may substantially freely change length when subject to a change in temperature, and that the loops are held by the holding means with said at least one loop comprising a part of the optical fibre, which comprises a number of reflecting structures, it is obtained that the at least one loop may be used to obtain a passive reference measurement, which is independent of any strain present in the part, whereby said reference measurement

may be used for providing compensation for temperature change in an active strain measurement performed on said part. By the at least one optical fibre at least extending between the connecting means and the holding means, and the at least one loop, which may substantially freely change length, being held by the holding means and comprising a part of the optical fibre, which comprises a number of reflecting structures, it is obtained that the connecting means and the holding means may be placed independently, with the only limitation being the length of the optical fibre, which may be chosen freely. This may be used to place the holding means near an active strain gauge placed on the part, whereby the temperature of the strain gauge and the loop on the optical fibre comprising the number of reflecting structures may be substantially identical, and hence very accurate temperature compensation may be obtained for a strain measurement performed by that particular strain gauge. Since also the connecting means may be placed freely, it may be placed at any convenient position suitable for connecting light emitting and light receiving means. Such free placing is of significant advantage by large and/or elongated parts, such as blades for wind turbines, which have lengths longer than 30 meters and widths of more than 3 meters, and where strain gauges may be employed at any position. By at least partly embedding the optical fibre, the connecting means and the holding means are the fibre-reinforced part of said device, and the items are well protected and safely kept in place. It is also obtained that the temperature of the optical fibre and the fibre-reinforced part are at least nearly identical.

[0004] In one advantageous embodiment the system may comprise one connecting means adapted for connection of light emitting means and one connecting means adapted for connection of light receiving means to the optical fibre, where the optical fibre extends from one of the connection means to another via at least one holding means. This provides two connections to the optical fibre, which e.g. leave a spare connection in case the optical fibre should break on one side of the holding means, which will disable connection to and from one of the connection means to the at least one loop, which may freely change length.

[0005] A preferred embodiment may involve that the system comprises two or more holding means, where each holding means comprises at least one loop comprising a part of the optical fibre, which comprises a number of reflecting structures. It is hereby obtained that accurate temperature compensation may be performed for two or more strain measurements performed with strain gauges placed in different places on fibre-reinforced the part. This is advantageous especially for large parts where it may be desired to monitor strain in more than one location.

[0006] Another preferred embodiment may involve that an optical fibre enters the holding means in one direction and exits in another direction. The holding means may in this way be used for changing direction of the path in which the optical fibre is led, e.g. towards another holding means or connecting means. Free positioning of the holding means and the connecting means is thereby enhanced.

[0007] Other features of a device according to the invention are the subject of claims 4 - 12.

[0008] Other features of the invention involve a method for manufacturing a device comprising

a fibre-reinforced part including a system adapted for use in temperature compensation of strain measurements, said system comprising at least one optical fibre as well as connecting means adapted for connection of light emitting means and light receiving means to the optical fibre, said optical fibre comprising a number of reflecting structures, where the system comprises at least one holding means adapted to hold one or more loops formed on the optical fibre, in a way where at least one loop may substantially freely change length when subject to a change in temperature, and where moulding means according to a predetermined shape of said device are provided as well as fibres for reinforcement and resin, where the method comprises independent steps of:

- connecting the optical fibre with the connecting means,
- forming part of the optical fibre into one or more loops and holding said loops with the holding means, in a way where at least one loop is substantially free to change length when subject to a change in temperature, said at least one loop comprising a part of the optical fibre, which comprises a number of reflecting structures,
- applying the fibres for reinforcement, the optical fibre, the connecting means, the holding means and the resin on the moulding means and forming the device in a way where the optical fibre, the connecting means and the holding means are at least partly embedded in at least the resin.

By such a method a device may be manufactured, where said device involves corresponding functions and technical effects as the aforementioned device according to the invention. The method steps are independent, since the optical fibre may e.g. be connected to the connecting means and/or holding means before or after the connecting and/or holding means are applied on the moulding means. The fibres for reinforcement may preferably be applied in a dry state along with the optical fibre, the connecting means and the holding means, where after the resin is infused in a state where air is evacuated, such as in a VARTM process (Vacuum Assisted Resin Transfer Moulding). The method may preferably be performed in a way where the optical fibre is connected with the connecting means, and where a part of the optical fibre is formed into a number of loops, and holding said loops with the holding means, in a way where at least one loop is substantially free to change length when subject to a change in temperature, said at least one loop comprising a part of the optical fibre, which comprises a number of reflecting structures, and where the optical fibre is wound onto at least one spool before the optical fibre, the connecting means and the holding means are applied. The optical fibre, which is fragile, may hereby stay protected on the spool during storage and handling until it is actually used.

According to another preferred feature, the optical fibre may be applied from the spool and continuously fastened to the fibres for reinforcement while being unwinded. The optical fibre thus stays protected at all time. Examples of preferred connecting means comprise connecting means adapted for connecting the light emitting means and light receiving means to the said at least one optical fibre, said connecting means comprising the housing adapted for storing and holding an end section of an optical fibre being formed with the at least one loop placed by said end section, connecting means comprising an elongate resilient portion, which portion is adapted to support an optical fibre when connected to the connecting means and connecting means, where the housing is provided with a shape, which is substantially frusto-conical or

substantially like a truncated pyramid.

[0009] Examples of holding means comprise: Holding means comprising a housing provided with at least one recess, said recess having at least one substantially circular path adapted for substantially surrounding loops formed on an optical fibre, holding means where the substantially circular path is connected with at least two recesses and holding means, wherein the housing is provided with a shape, which is substantially frusto-conical or substantially like a truncated pyramid. In the following the invention is described with reference to the drawings, which display examples of embodiments of the invention.

Fig. 1

shows one side of a device according to the invention,

Fig. 2

shows one side of another device,

Fig. 3

shows an elevated view of connecting means,

Fig. 4

shows an elevated view of holding means,

Fig. 5

shows a holding means seen from above, and

Fig. 6

shows another holding means seen from above

Fig. 7

shows one side of an alternative embodiment of a device

Fig. 8

shows a configuration of more devices for use in a wind turbine

Fig. 9

shows another configuration of more devices for use in a wind turbine

[0010] Fig. 1 displays a device 1 comprising a fibre-reinforced part 2, where the device 1 in this example is a blade 11 for a wind turbine. Near the root of the blade 11 two connecting means 5 are placed, where to an optical fibre 4 is connected. Between the connecting means 5 the optical fibre 4 is placed in three individual holding means 6, each holding one or more loops 7 formed on the fibre 4, said loops 7 including at least one loop, which may freely change length when subject to a change in temperature, and which includes a number of reflecting structures, such as Bragg gratings.

[0011] Fig. 2 displays a device 1 corresponding to Fig. 1, however having connecting means 5 being integrated in a common housing 18.

[0012] Fig. 3 displays a particular embodiment of connecting means 5 including a housing 13, which has a general shape as a truncated pyramid. An optical fibre 4, which is supported by a string 10, is via a tapered, elongate and resilient portion 12 lead into a depression in the

housing 13 and laid in a loop, which is fixated with resilient glue 20, and finally ending in a free loop having a plug 19 connected. The plug 19 is intended for connection to undisplayed light emitting and/or light receiving means. To ease forming of a loop on the fibre 4 and holding this in place while the glue 20 is curing, a wall 21 may be placed on the housing, or it may be machined or cast when the housing 13 is made. The housing 13 will in use be covered by e.g. a plate, preferably resting on an undisplayed seal to form a tight connection. When manufacturing a device, the connecting means 5 may be placed on a moulding means with the undisplayed plate facing said moulding means, where after reinforcement fibres are placed around the connecting means 5 and resin introduced. After curing of the device, the plate will be facing a surface of the device and the connecting means 5 be accessed from an internal side by removing the plate.

[0013] Fig. 4 displays holding means 6 comprising a housing 14 provided with a recess 15 including a circular path 16, which is connected to recesses 17. The circular path 16 is adapted to hold one or more loops 7 formed on an optical fibre 4, where at least one loop comprises a number of reflecting structures, such as Bragg gratings. The fibre 4 is fixed in the recesses 17 with resilient glue and enters and exits, respectively, the housing 14 via resilient portions 22. The fibre 4 may be supported by a string 10, e.g. made from woven or braided glass fibres. The loops 7 lay loose and have a slightly smaller diameter than the circular path 16, and may hence slide substantially without resistance, and are hence free to change length when subject to a change in temperature. The housing 14 may be closed with an undisplayed plate in a similar way as explained above with regard to the connecting means 5, and the holding means 6 may be placed in a similar way during manufacture to obtain internal access. Both the housings 13 and 14 may preferably be made from a polymeric material by processes involving casting, milling or the like.

[0014] Fig. 5 and 6 display a housing 14 comprising a recess 15 having a circular path 16 and two connecting recesses 17. As shown, the recesses 17 may be adapted to extend in different directions, whereby an undisplayed optical fibre placed in loops in the circular path 16 and exiting via the recesses 17 may be led in different directions. In Fig. 6 it is shown that the recesses 15, 17 and the circular path 16 may be placed in a depression 25, where they may be covered by an undisplayed plate and fixed with screws placed in holes 24. A fibre may enter and exit via holes 26.

[0015] Fig. 7 displays a device 1 comprising a fibre-reinforced part 2, where the device 1 in this example is a blade 11 for a wind turbine. Near the root of the blade 11 one connecting means 5 is placed, where to an optical fibre 4 is connected. From the connecting means 5 the optical fibre 4 is extending to holding means 6, and is here placed in three individual holding means 6, each holding one or more loops 7 formed on the fibre 4, said loops 7 including at least one loop, which may freely change length when subject to a change in temperature, and which includes a number of reflecting structures. At the farthest holding means 6 the fibre 4 ends in a free end 27.

[0016] Fig. 8 and 9 each display a device 1 comprising three fibre-reinforced parts, which

here are three blades 11 for a wind turbine. Optical fibres 4 are each led in a path in the blades 11. The optical fibres 4 are in Fig. 8 connected from blade to blade via connection means 5. The optical fibres 4 extend via non-displayed holding means 6, each holding one or more non-displayed loops 7 formed on the fibre 4, said loops 7 including at least one loop, which may freely change length when subject to a change in temperature, and which includes a number of reflecting structures. In Fig. 8 one fibre 4 ends in an end 27, which is not connected to connection means, whereas in Fig. 9 all three fibres 4 end in non-connected ends 27. In Fig. 8 and 9 light emitting and light receiving means 26 are provided, by which light is emitted into the fibres 4, and some light is reflected by the reflecting structures, and is then received by the means 26.

[0017] As depicted in Fig. 3, the connecting means 5 comprise an elongate resilient portion 12, which portion is adapted to support an optical fibre 3 when connected to the connecting means.

[0018] The housing 13 of the connecting means 5 and/or the housing 14 of the holding means 6 may be provided with a shape, which is substantially frusto-conical or substantially like a truncated pyramid.

[0019] The housings 13, 14 of the connecting means 5 and the holding means 6 may be made from a polymeric material, whereby said means as well as the optical fibre 4 are made essentially without using any e.g. metallic parts to maintain a generally low risk of a lightning strike in said means, although the connecting means 5 may include metallic plugs 19 for connecting the optical fibre 4 to means for emitting and receiving light, respectively.

[0020] It is to be understood that the invention as disclosed in the description and in the figures may be modified and changed and still be within the scope of the invention as claimed hereinafter.

REFERENCES CITED IN THE DESCRIPTION

This list of references cited by the applicant is for the reader's convenience only. It does not form part of the European patent document. Even though great care has been taken in compiling the references, errors or omissions cannot be excluded and the EPO disclaims all liability in this regard.

Patent documents cited in the description

- [WO03076887A \[0001\]](#)

KRAV

1. En indretning (1) omfattende en fiberforstærket del (2,11) og omfattende i det mindste et system til anvendelse i temperaturkompensation for belastningsmålinger, hvor systemet omfatter
- 5 i det mindste en optisk fiber (4) og et forbindelsesorgan (5) indrettet til forbindelse med lysemitterende midler og lysmodtagende midler til den optiske fiber, idet den optiske fiber (4) omfatter et antal reflekterende strukturer, hvor
- systemet omfatter i det mindste et holdeorgan (6) indrettet til at holde en eller flere sløjfer (7) dannet af den optiske fiber (4) på en sådan måde, at i det mindste en sløjfe (7) kan i
- 10 hovedsagen frit ændre længde, når den udsættes for en temperaturændring, hvor en flerhed af de reflekterende strukturer tilvejebringer et temperaturafhængigt respons for temperaturkompensation for belastningsmålinger,
- og hvor den i det mindste ene optiske fiber (4) i det mindste strækker sig mellem forbindelsesorganet (5) og holdeorganet (6),
- 15 og hvor den i det mindste ene sløjfe (7), som i hovedsagen kan frit ændre længde, holdes af holdeorganet (6) og omfatter en del af den i det mindste ene optiske fiber (4), der omfatter flerheden af reflekterende strukturer,
- kendetegnet ved, at den optiske fiber (4), forbindelsesorganet (6) og holdeorganet (6) er i det mindste delvist indlejret i den fiberforstærkede del (2,11) af indretningen (1).
- 20
2. En indretning ifølge krav 1, hvor systemet omfatter i det mindste et forbindelsesorgan indrettet til forbindelse med lysemitterende midler og lysmodtagende midler til den optiske fiber, og hvor den i det mindste ene optiske fiber strækker sig fra et forbindelsesorgan til et andet forbindelsesorgan via i det minste et holdeorgan.
- 25
3. En indretning ifølge krav 1 eller 2, hvor systemet omfatter to eller flere holdeorganer, og hvor hvert holdeorgan omfatter i det mindste en sløjfe omfattende en del af den i det mindste ene optiske fiber, der omfatter et antal reflekterende strukturer.
- 30
4. En indretning ifølge et eller flere af kravene 1-3, hvor den i det mindste ene optiske fiber går ind i holdeorganet i én retning og går ud i en anden retning.

5. En indretning ifølge krav 1, hvor to forbindelsesorganer er integreret i et fælles hus.
6. En indretning ifølge et eller flere af kravene 1-5, hvor forbindelsesorganet er indrettet til at
5 være tilgængelig fra en indre pposition inden for den nævnte del.
7. En indretning ifølge et eller flere af kravene 1-6, hvor den i det mindste ene optiske fiber i det mindste mellem forbindelsesorganet og holdeorganet er tilvejebragt med understøttelsesmidler til forstærkelse af den i det mindste ene optiske fiber.
- 10
8. En indretning ifølge krav 7, hvor understøttelsesmidlerne omfatter en streng omfattende vævede eller flettede fibre, fortrinsvist glasfibre.
9. En indretning ifølge krav 8, hvor den i det mindste ene optiske fiber er fastgjort til strengen
15 med dobbeltbelagt tape.
10. En indretning ifølge krav 8, hvor den i det mindste ene optiske fiber er integreret i strengen, fortrinsvist via vævning eller fletning.
- 20 11. En indretning ifølge et eller flere af kravene 1-10, hvor forbindelsesorganet og holdeorganet hvert omfatter en fordybning, i hvilken en del af den i det mindste en optiske fiber er fastgjort med lim.
12. En indretning ifølge et eller flere af kravene 1-11, hvor hvor den nævte del er et
25 fiberforstærket skallegeme til en vinge til et vindenergianlæg.
13. En fremgangsmåde til fremstilling af en indretning (1) omfattende en fiberforstærket del (2,11) og omfattende et system til anvendelse i temperaturkompensation for belastningsmålinger, hvor systemet omfatter i det mindste en optisk fiber (4) og et forbindelsesorgan (5) indrettet til
30 forbindelse med lysemitterende midler og lysmodtagende midler til den optiske fiber, idet den optiske fiber (4) omfatter et antal reflekterende strukturer, hvor systemet omfatter i det mindste

et holdeorgan (6) indrettet til at holde en eller flere sløjfer (7) dannet af den optiske fiber (4) på en sådan måde, at i det mindste en sløjfe (7) kan i hovedsagen frit ændre længde, når den udsættes for en temperaturændring, og hvor støbelegemer ifølge en forudbestemt form af indretningen (1) er tilvejebragt såvel som fibre til forstærkning og resin, hvor fremgangsmåden

5 omfatter følgende uafhængige trin:

forbindelse af den i det mindste ene optiske fiber (4) med forbindelsesorganet (5),

dannelse af i det mindste en del af den i det mindste en optiske fiber (4) til en eller flere sløjfer (7) og holde nævnte sløjfer med holdeorganet (6) på en måde, så i det mindste en sløjfe (7) er i hovedsagen fri til at ændre længde, når den udsættes for en temperaturændring, idet den i

10 det mindste ene sløjfe (7) omfatter en del af den i det mindste ene optiske fiber (4), som omfatter et antal reflekterende strukturer,

tilførelse af fibre til forstærkning, den i det mindste ene optiske fiber (4), forbindelsesorganet (5), holdeorganet (6) og resin til støbelegemet, og

kendetegnet ved, at fremgangsmåden omfatter trinnet til dannelse af indretningen (1) på en

15 måde, hvor den i det mindste ene optiske fiber (5), forbindelsesorganet (5) og holdeorganet er i det mindste delvist indlejret i resinen.

14. En fremgangsmåde ifølge krav 13, hvor den i det mindste ene optiske fiber er forbundet med forbindelsesorganet, og hvor en del af den i det mindste en optiske fiber dannes til en eller flere

20 sløjfer, og holde den ene eller flere sløjfer med holdeorganet på en sådan måde, at i det mindste en sløjfe er i hovedsagen fri til at ændre længde, når den udsættes for en temperaturændring, i det den i det mindste ene sløjfe omfatter en del af den i det mindste ene optiske fiber, der omfatter et antal reflekterende strukturer, og hvor den i det mindste ene optiske fiber er viklet på i det mindste en spole før den i det mindste ene optiske fiber, forbindelsesorganet og holdeorganet

25 påføres støbelegemet.

15. En fremgangsmåde ifølge krav 14, hvor den i det mindste ene optiske fiber påføres fra spolen og kontinuerligt fastgøres til fibre til forstærkning, mens den afspoles.

DRAWINGS

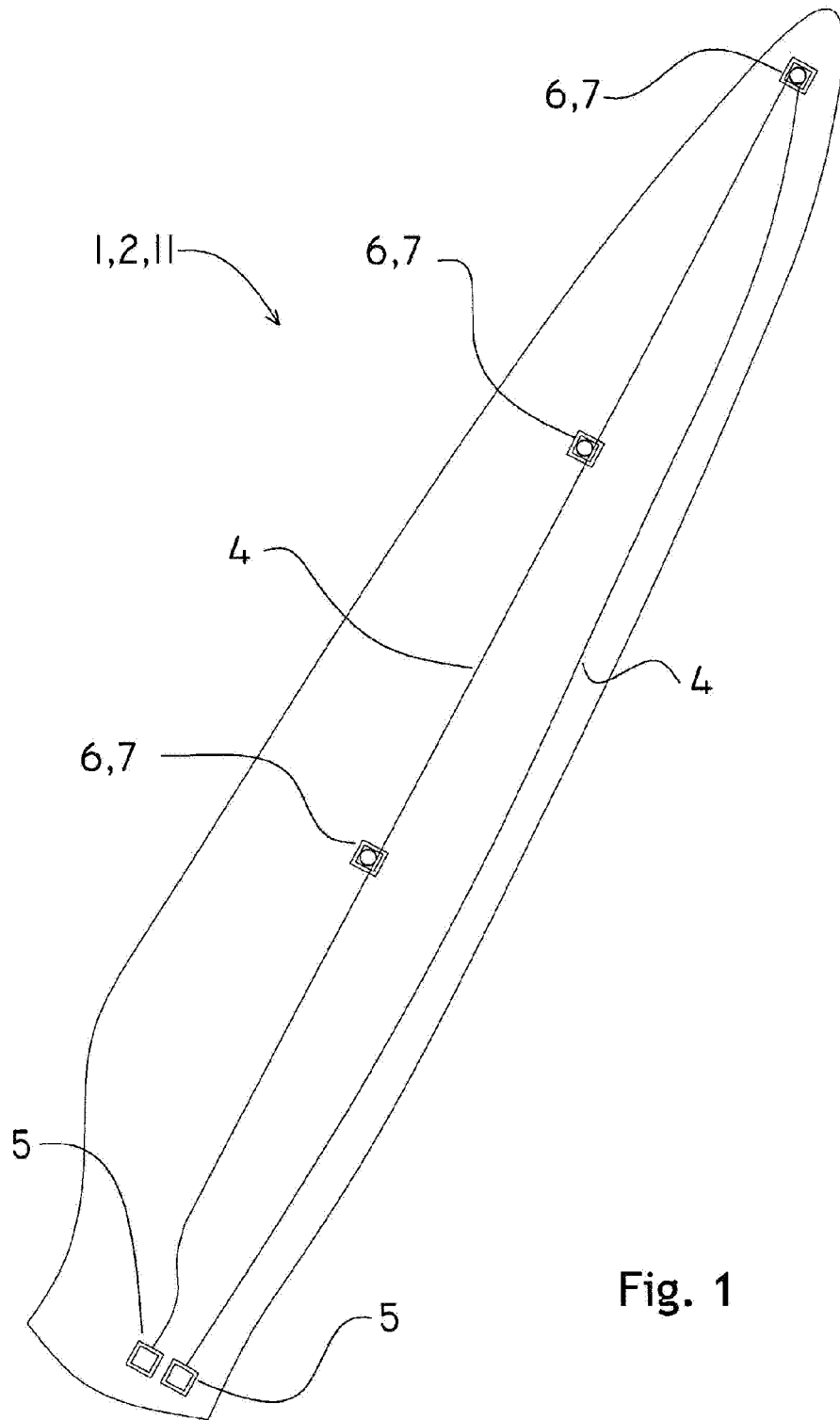

Fig. 1

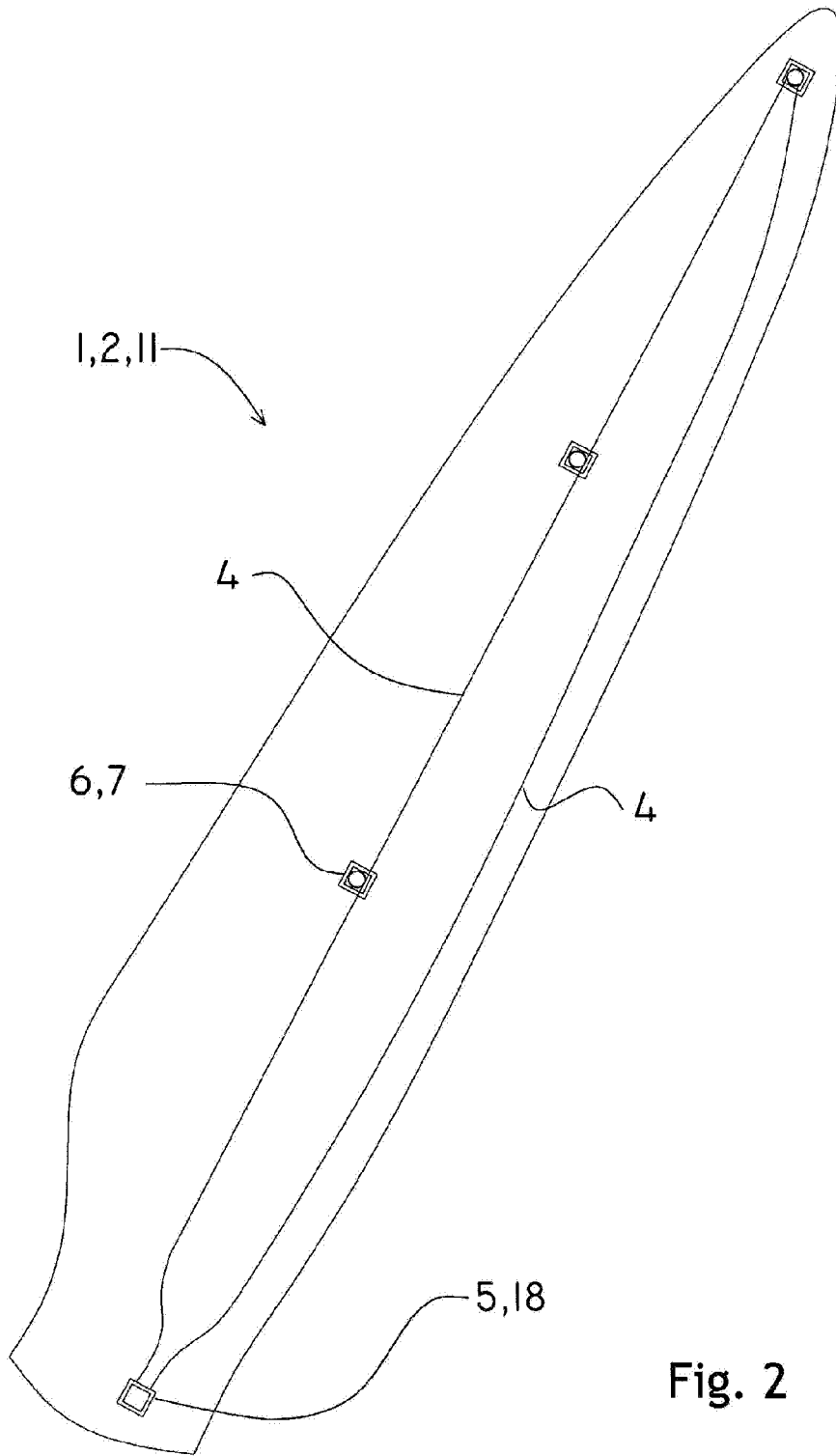

Fig. 2

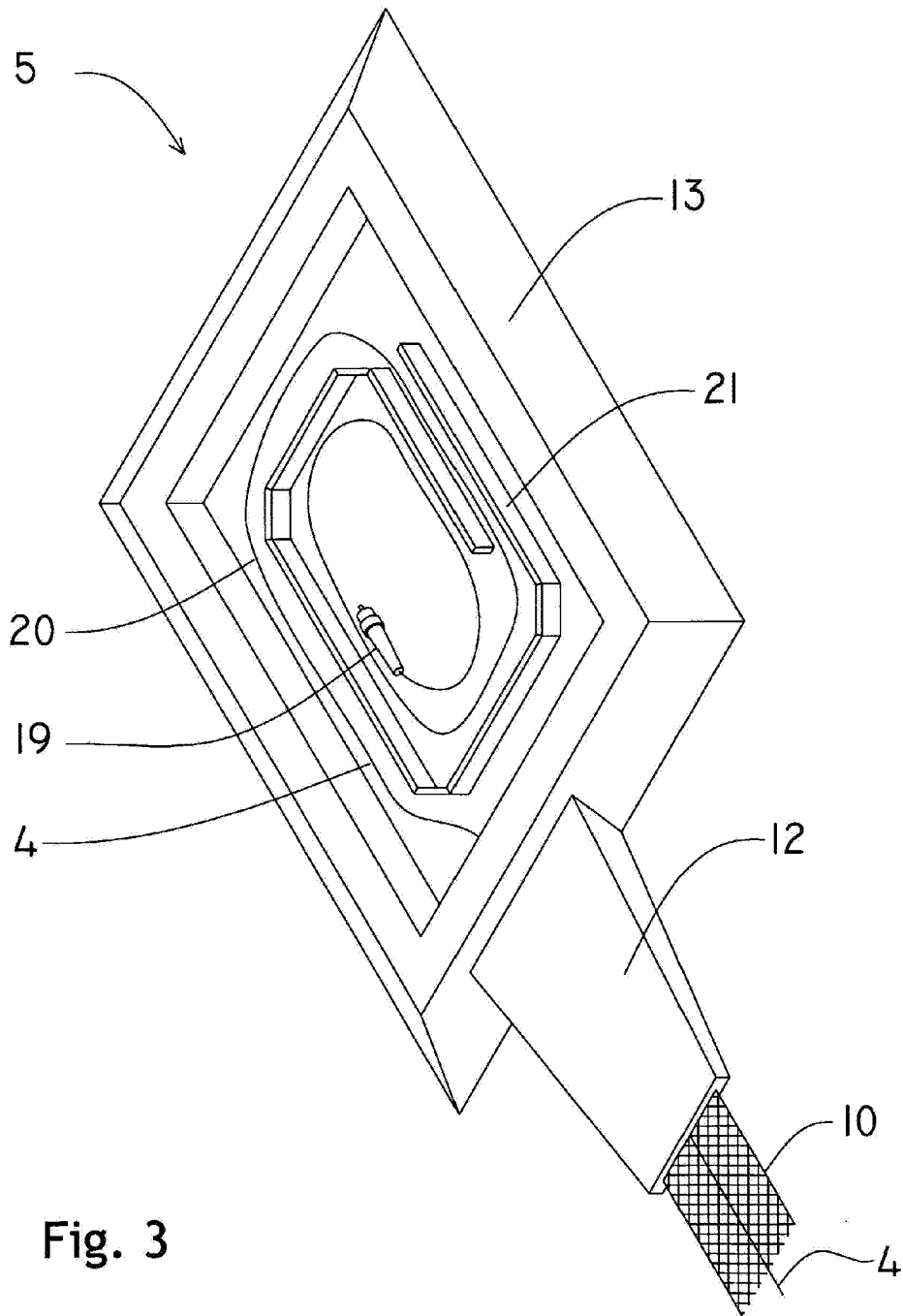

Fig. 3

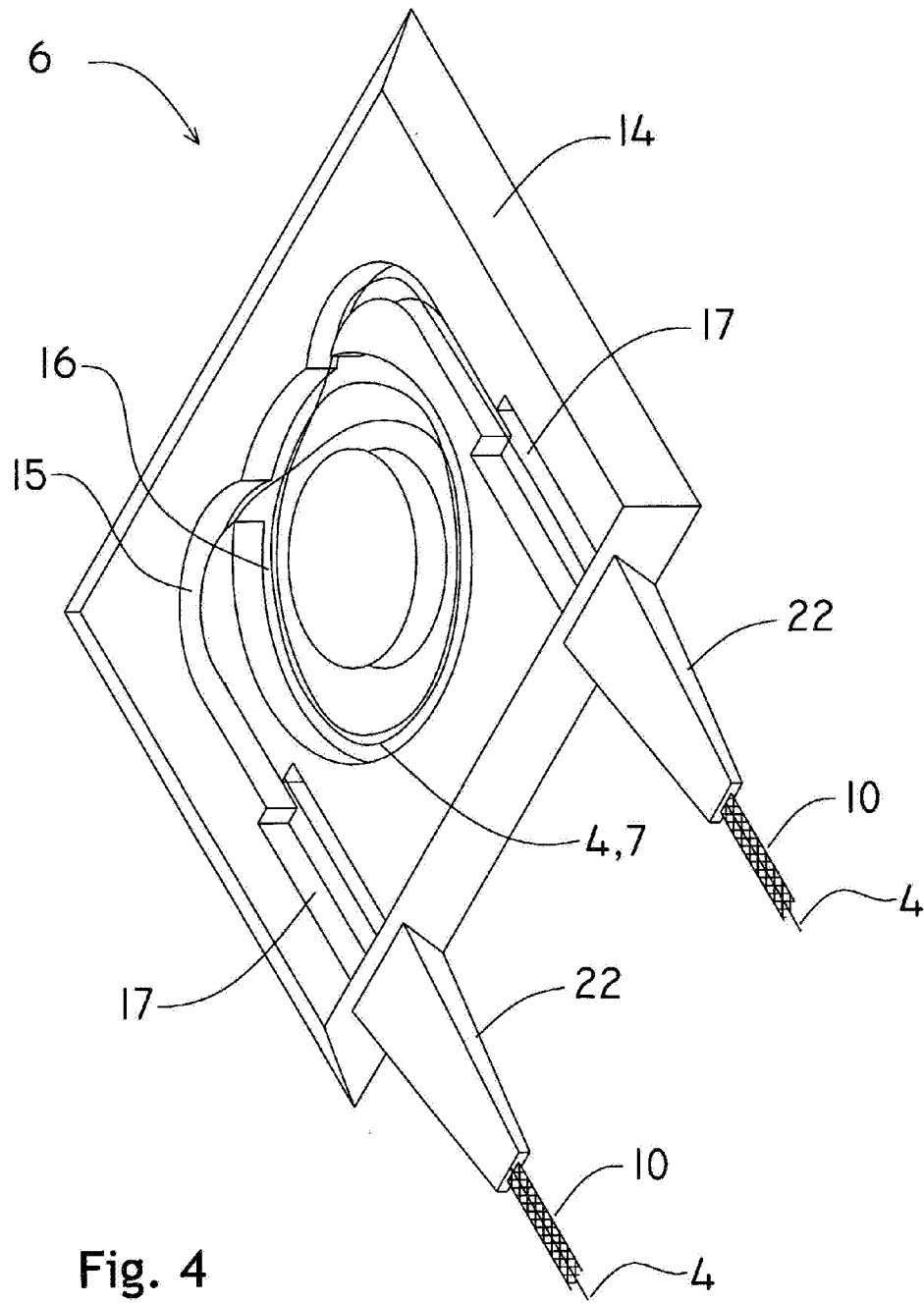
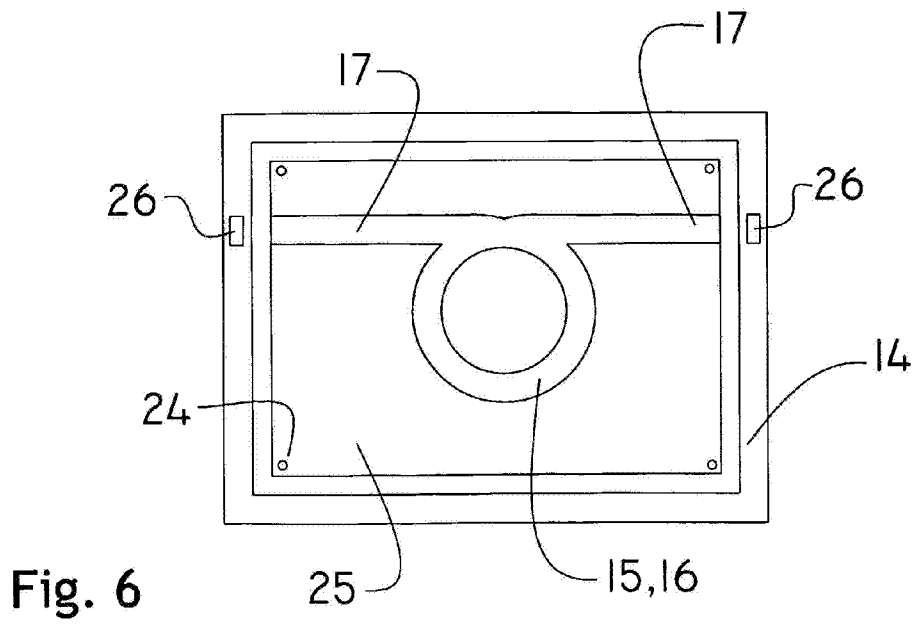
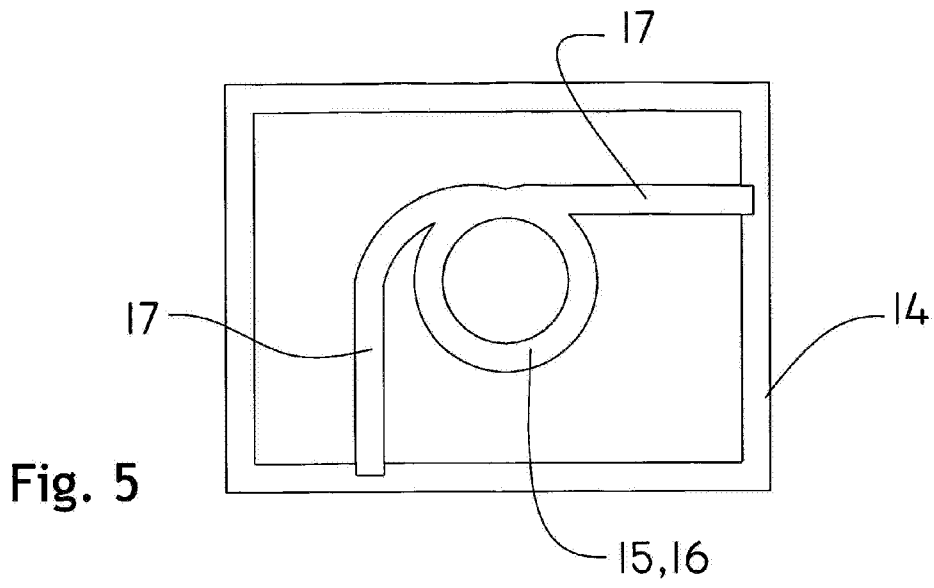

Fig. 4



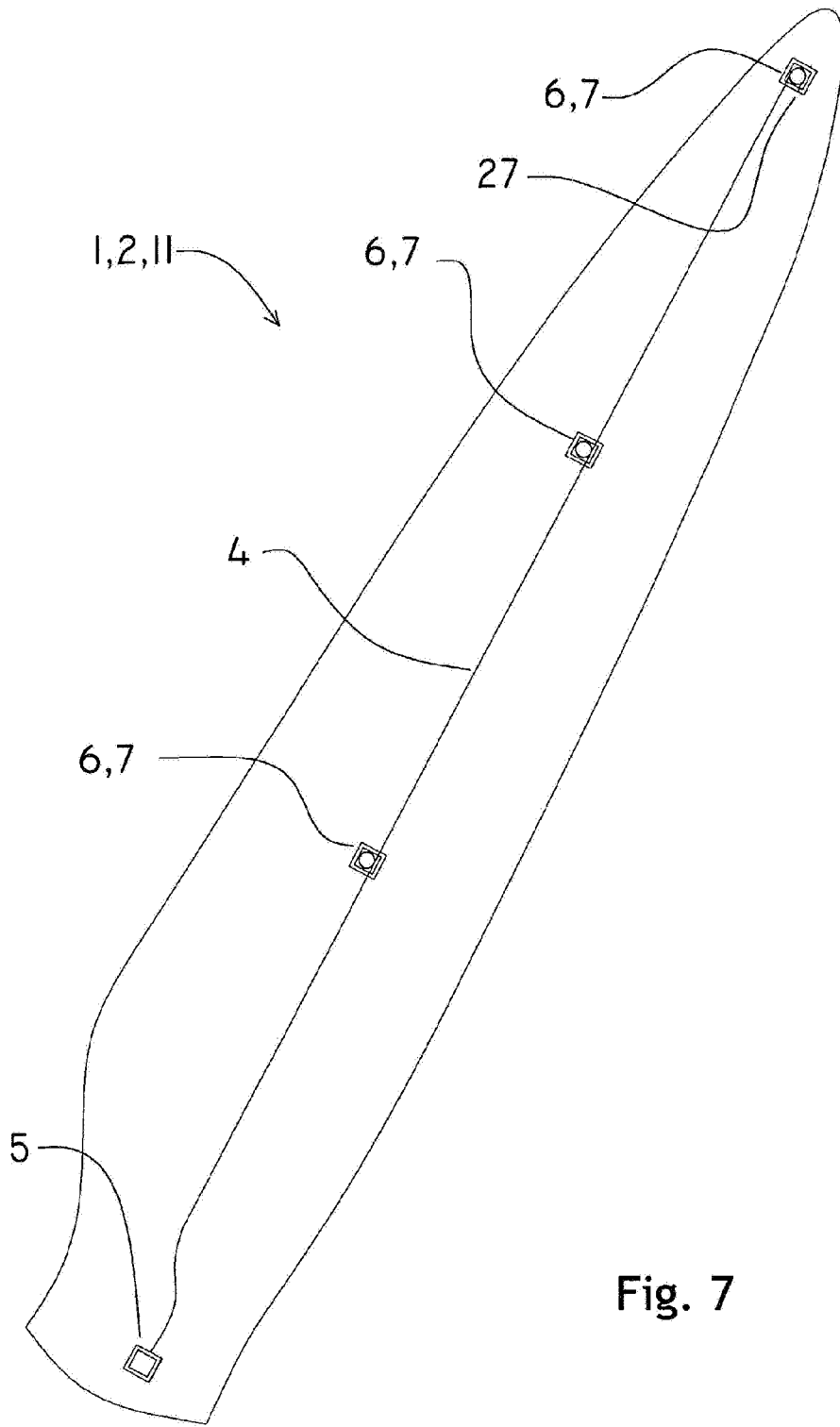

Fig. 7

