

(19) World Intellectual Property
Organization
International Bureau



(43) International Publication Date
15 April 2004 (15.04.2004)

PCT

(10) International Publication Number
WO 2004/031684 A1

- (51) International Patent Classification⁷: G01B 5/012, 7/012
- (21) International Application Number: PCT/EP2003/010805
- (22) International Filing Date: 29 September 2003 (29.09.2003)
- (25) Filing Language: English
- (26) Publication Language: English
- (30) Priority Data: BO2002A000628 7 October 2002 (07.10.2002) IT
- (71) Applicant (for all designated States except US): MARPOSS SOCIETÀ PER AZIONI [IT/IT]; Via Saliceto, 13, I-40010 Bentivoglio (IT).
- (72) Inventors; and
- (75) Inventors/Applicants (for US only): BARUCHELLO, Roberto [IT/IT]; 1854 Windwood Drive, Apt. 204, Rochester Hills, MI 48307 (US). FORNI, Alessandro [IT/IT]; Via dei Martiri, 12 - Amola, I-40017 S. Giovanni in Persiceto (IT).
- (74) Common Representative: MARPOSS SOCIETÀ PER AZIONI; Via Saliceto, 13, I-40010 Bentivoglio (IT).
- (81) Designated States (national): AE, AG, AL, AM, AT, AU, AZ, BA, BB, BG, BR, BY, BZ, CA, CH, CN, CO, CR, CU, CZ, DE, DK, DM, DZ, EC, EE, EG, ES, FI, GB, GD, GE, GH, GM, HR, HU, ID, IL, IN, IS, JP, KE, KG, KP, KR, KZ, LC, LK, LR, LS, LT, LU, LV, MA, MD, MG, MK, MN, MW, MX, MZ, NI, NO, NZ, OM, PG, PH, PL, PT, RO, RU, SC, SD, SE, SG, SK, SL, SY, TJ, TM, TN, TR, TT, TZ, UA, UG, US, UZ, VC, VN, YU, ZA, ZM, ZW.
- (84) Designated States (regional): ARIPO patent (GH, GM, KE, LS, MW, MZ, SD, SL, SZ, TZ, UG, ZM, ZW),

[Continued on next page]

(54) Title: TOUCH PROBE COMPRISING A SWITCH WITH CONTACTS PROTECTED BY INERT GAS

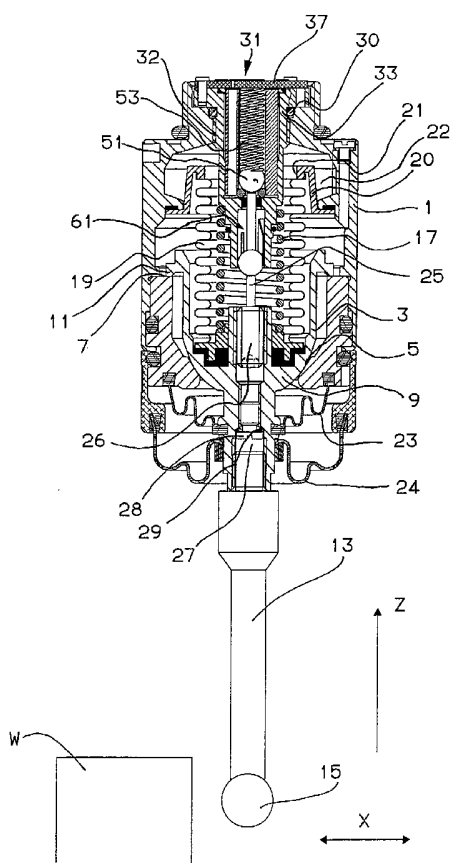

(57) Abstract: A touch probe with an arm (13) coupled to a movable arm-set (3) supported in a casing (1) includes an electric switch (31) with a housing (33) fixed to the casing and a mechanical transmission device (61) for mechanically transmitting displacements of the arm, and causing the disengagement of a conductive small ball (51) from two stationary conductive bars (44,45), thereby opening an electric detecting circuit. At the interior of the probe casing, a sealingly closed chamber houses the switch and is filled with inert gas, for example nitrogen, for protecting the electric contacts.

WO 2004/031684 A1



Eurasian patent (AM, AZ, BY, KG, KZ, MD, RU, TJ, TM),
European patent (AT, BE, BG, CH, CY, CZ, DE, DK, EE,
ES, FI, FR, GB, GR, HU, IE, IT, LU, MC, NL, PT, RO,
SE, SI, SK, TR), OAPI patent (BF, BJ, CF, CG, CI, CM,
GA, GN, GQ, GW, ML, MR, NE, SN, TD, TG).

— *before the expiration of the time limit for amending the claims and to be republished in the event of receipt of amendments*

Published:

— *with international search report*

For two-letter codes and other abbreviations, refer to the "Guidance Notes on Codes and Abbreviations" appearing at the beginning of each regular issue of the PCT Gazette.

- 1 -

DESCRIPTION

TOUCH PROBE COMPRISING A SWITCH WITH CONTACTS PROTECTED BY INERT GAS

5

Technical Field

The invention relates to a touch probe, including a casing that defines a longitudinal geometric axis, a movable arm-set housed in the casing, an arm rigidly coupled to the movable arm-set, with an end extending out of the casing, a feeler coupled to said end of the arm, and an electric switch adapted for detecting displacements of the movable arm-set with respect to the casing and including at least a stationary contact and a movable contact, a housing enclosing the stationary contact and the movable contact and a contact protecting fluid for protecting the contacts, and a mechanical transmission device adapted for transmitting displacements of the movable arm-set to the movable contact.

20

Background Art

Touch probes with movable arm-sets that carry feelers are utilized in coordinate measuring machines and in machine tools, more specifically in machining centers and lathes, for carrying out checkings on machined or to be machined pieces, on the tools, on the machine tables, etc. In each of these probes, contact between feeler and, for example, a mechanical piece is monitored by suitable devices which detect specific displacements of the movable arm-set with respect to a casing and control the reading of transducers associated with the machine slides, that provide measurement values with respect to a reference position or origin.

35 A probe detecting and monitoring device can foresee the utilization of an electric circuit and of (at least) an associated switch that, actuated in a mechanical way as a

- 2 -

result of displacements occurring between the movable arm and the casing, causes the closure or, more frequently, the opening of the circuit.

The U.S. patent No. US-A-5299360 discloses probes according to the preamble of claim 1, each including a microswitch with a stem having a free end that cooperates with the movable arm-set. More specifically, in each of said probes, the coupling between the movable arm-set and the stationary casing is such that, further to displacements of the feeler in a longitudinal direction or in a transversal direction, there occurs the lifting of an abutment surface of the movable arm-set that is near the microswitch and the consequent thrust on the stem, the disengagement of the contacts and the opening of the electric circuit.

An extremely important characteristic that touch probes are required to have is a high standard of repeatability i.e. a close correlation between specific positions taken by the feeler and the opening of the electric circuit.

In order to improve said characteristic, the mutual arrangement among the component parts of the switch is accurately defined insofar as, among other things, the aligning - along a longitudinal axis of the thrust spring - of the movable contact, generally ball shaped, and of the stem is concerned. Although the probes disclosed in patent No. US-A-5299360 guarantee good repeatability, an absolutely perfect alignment between the component parts of the switch is not however possible. Furthermore, variations in the mutual positions of the stem and of the other component parts of the microswitch due to clearances in the longitudinal guide system and/or possible rotations of the stem about its axis, even though of extremely small entity, can negatively affect the repeatability of the probe. This is especially true in recent high precision applications in which it is required that the repeatability errors be particularly small, considerably smaller than 1 μ m.

Other inconveniences that occur in the known probes as, for example, those disclosed in the formerly mentioned patent

- 3 -

No. US-A-5299360, but not just in those probes, hang on the reliability of the electric contacts of the microswitch. In fact, although the probes are protected by gaskets of various types, they cannot be, in general, considered hermetically sealed, more particularly the rubber gaskets are not entirely sealed against oxygen and water vapour. These two elements, oxygen and water vapour, put together or separately, concur to oxidation processes of the microswitch electric contacts and hence lead to cause malfunctionings, that can affect the reliability of the probe. In order to avoid the occurring of these negative processes, it is known to utilize, at the interior of the microswitch, lubricating fluid ("oil") for protecting the contacts. However, although the presence of oil considerably improves the reliability of the contacts, it can interfere with the metrological performance of the probe, in particular negatively affect its repeatability. In fact, the instant when the opening of the contacts - that are fed with very low voltages - is detected can be altered in an unforeseeable way owing to the presence of oil on the contacts.

Disclosure of Invention

An object of the present invention is to provide touch probes that, by maintaining the known structure substantially unaltered and by utilizing extremely simple and economic means, attain an improvement in the performance and, in particular, an extremely high standard of repeatability.

This object is achieved by a probe according to claim 1. An important advantage that the invention provides is an effective improvement in the performance of the probes, and thus a more accurate machining of the pieces controlled by said probes, by utilizing extremely simple and economic means.

- 4 -

Brief Description of the Drawings

Other profitable features of the invention will appear from the following detailed description when considered in connection with the enclosed sheets of drawings, given by way of non-limiting example, wherein:

figure 1 is a longitudinal cross-sectional view of a touch probe according to a preferred embodiment of the invention, with some details shown in front view;

figure 2 is an enlarged longitudinal cross-sectional view of a component of the probe shown in figure 1; and

figure 3 shows the component of figure 2, when viewed from the bottom and in the direction indicated by arrow III of figure 2.

Best Mode for Carrying Out the Invention

The probe shown in figure 1 includes support means with a casing **1** - that is hollow, of a substantially cylindrical shape and consists, for example, of a plurality of mutually assembled portions - that defines a longitudinal geometric axis, and a movable arm-set **3** housed and supported in casing **1**. Casing **1** includes two reference areas for the movable arm-set, more specifically a substantially frusto-conical seat **5** and an abutment area **7** with plane annular surface. In turn the movable arm-set **3** defines a longitudinal axis of symmetry and includes a central reference portion **9**, having substantially the shape of a spherical segment defining a spherical zone, and an abutment flange **11** with annular surface. An arm **13** is coupled to the movable arm-set **3** and a feeler **15** is fixed to a free end of arm **13**.

A helical spring **17** has its ends in abutment against two plane surfaces, integral with the movable arm-set **3** and the casing **1**, respectively, and urges the central reference portion **9** against seat **5**.

When movable arm-set **3** is in the inoperative condition of

- 5 -

figure 1, symmetrically arranged with respect to the longitudinal geometric axis defined by casing **1**, the substantially spherical zone of the central portion **9** is housed in seat **5** with substantially circular mutual contact, whereas the annular surface of the abutment flange **11** is at a distance of a few micrometers from the abutment area **7** of casing **1**. The existence of this clearance, that cannot be identified in the figure, determines the correct operation of the head according to the described embodiment, as detailedly outlined in the formerly mentioned patent No. US-A-5299360, to which reference can be made for a more detailed description.

It should be noted that a different embodiment of the present invention - that will be more extensively disclosed in the following description - foresees, instead, that the abutment flange **11** be - when the probe is in the inoperative condition - in contact with the abutment area **7** of casing **1**, urged by the thrust of spring **17**. In this case there will be a radial clearance of a few micrometers between the central portion **9** of the movable arm-set **3** and the seat **5**.

An antirotation device, adapted for preventing the rotation of the movable arm-set **3** about the previously mentioned longitudinal axis of symmetry, includes a metal bellows **19** fixed to the arm-set **3** and to a suitable mechanical coupling element, or bucket, **20**, rigidly coupled (for example glued) to casing **1**. The bucket **20** has an axial opening **21** and is coupled to casing **1** in such a way to define, with internal surfaces of casing **1**, a recess **22**, in communication with the interior of the bellows **19**.

Two flexible, protective and sealing elements **23** and **24** are arranged between the arm **13** and the casing **1**.

The contact occurring between feeler **15** and a piece **W** is detected, after completion of a determined pre-stroke in the longitudinal direction, or, in the case of displacements of the feeler **15** in the transversal direction, at a determined angle between the geometric axis

- 6 -

of casing **1** and the axis of symmetry of the arm-set **3**, by means of a detecting device including an electric switch, or microswitch **31**, rigidly coupled to the casing **1** of the probe, for example, by means of a threaded coupling **32** and
5 a ring gasket (or "O-ring") **30**.

The microswitch **31**, also illustrated in figures 2 and 3, includes a housing **33** with a longitudinal through hole that defines two cylindrical openings **34** and **35**, with different diameter. A closure plate **37**, made from insulating
10 material, is fixed to housing **33** by means of rivets or screws **43** and seals - by compressing in a suitable seat a ring gasket (or "O-ring") **36** - an end of the through hole located at opening **34**. Plate **37** carries, on its external surface, electrically-conductive tracks **38** and **39**, shown in
15 simplified, cross-sectional form in figure 2.

A cylindrical insulating element **41**, for example made from plastic, is inserted in the opening **34** and fitted into it and defines an axial guide hole **42** that is consequently located in a substantially concentric position with respect
20 to the longitudinal geometric axis.

Stationary contacts are achieved by means of two cylindrical conductive bars **44** and **45**, inserted and also fitted into associated mutually parallel transversal seats **46** and **47** defined in part by the insulating element **41** and
25 in part by internal surfaces of the opening **34**, with a disk made from insulating material arranged therebetween, the disk being represented in simplified form by a thick line and identified by reference number **49** in figure 2. The disk **49** electrically insulates the bars **44** and **45** from housing
30 **33**, the latter being made from conductive material.

A small ball **51** made from electrically-conductive material provides a movable contact and is housed, with small clearance, in hole **42**. A compression spring **53**, also inserted in hole **42**, urges the small ball **51** against the
35 bars **44** and **45**. When the small ball **51** contacts both bars **44** and **45**, the microswitch **31** is closed, whereas when the small ball **51** disengages from at least one of bars **44** and

- 7 -

45, the microswitch **31** is open.

Electrically-conductive elements or wires, not shown in the drawings for the sake of simplicity and clarity, are housed in longitudinal holes **55** (one is shown in the figures) and
5 electrically connect the bars **44** and **45** to the two
conductive tracks **38** and **39**, respectively, that are in turn
coupled to the leads of a cable, not shown in the drawings,
for connecting - possibly by means of wireless transmission
devices, interface devices, etc. - the microswitch **31** to a
10 known control and measurement detecting unit, not shown in
the drawing either.

Furthermore, microswitch **31** includes an actuator, or
mechanical transmission device, **61** - for transmitting to
the movable contact **51** displacements of the movable arm-set
15 **3** - substantially housed in the cylindrical opening **35**. An
elongate mechanical body **63** of the transmission device **61**
is arranged substantially along a longitudinal direction
and includes two abutment ends that protrude from the
opposite ends of the opening **35**, for cooperating,
20 respectively, with the small ball **51** in opening **34** and with
the end of a transmission pin **25**, that is part of the
movable arm-set **3** and is substantially aligned along the
longitudinal axis of symmetry.

The elongate mechanical body **63** includes a pushing stem **65**
25 and a transmission element **67** with substantially spherical
surface, the latter being integrally coupled, for example
glued, to an end of the former.

The mechanical transmission device **61** also includes guide
elements for the body **63**. More specifically, a bushing **69** -
30 per se known, for example made from sapphire - is
internally fixed to the housing **33**, in an intermediate
portion with reduced diameter, between the openings **34** and
35 and contributes to guide, with limited clearance,
longitudinal displacements of stem **65** near small ball **51**.
35 The internal surface of opening **35** defines substantially
longitudinal guide surfaces that achieve a binary **71**, said
surfaces being, in the embodiment shown in the figures, the

- 8 -

lateral ones of a pair of cylindrical bars **70** and **72** arranged side by side, glued at the interior of said opening **35**. The cylindrical bars **70** and **72** are made, for instance, from zirconium oxide, which is a material that, like sapphire, does not conduct and has specific hardness characteristics, low friction coefficient and high resistance to corrosion and wear.

Among the guide elements there is an elastic thrust element, more specifically a bent flat spring **73**, also housed in opening **35** at an opposite position with respect to the surfaces that define the binary **71**. More specifically, housing **33** includes, at the part ending with opening **35**, a longitudinal slit **75** where the flat spring **73** is inserted in such a way that a larger end **74** of said spring **73** transversally extends out of the slit **75** (figure 3). An annular locking element **76** (for example, an elastic element) is located in a suitable annular seat of the external surface of the housing **33** and prevents the falling of the flat spring **73**. The bent flat spring **73** cooperates on one side with the housing **33** (transversal thrust between the larger end **74** and the walls of the slit **75**) and on the other side with the transmission element **67** at a substantially plane portion **77** of its surface - otherwise of a spherical shape - of the latter element.

The flat spring **73** transversally urges the transmission element **67** against the surfaces of the binary **71** with an extremely limited force (for example, just a few grams) that is sufficient for causing the longitudinal displacements of element **67** to be guided by the surfaces of the binary **71** free of clearances. Moreover, the specific geometric features and the arrangement of the mechanical body **63** determine that, thanks to the thrust that spring **73** applies to the transmission element **67**, the pushing stem **65** leans in a repeatable way on an identical area of the guide surface of the bushing **69**, at the opposite side with respect to the binary **71**, so as to achieve that the longitudinal displacements of the whole body **63** be guided

- 9 -

free of clearance and in a repeatable way, according to a defined kinematic trajectory.

The previously mentioned transmission pin **25** is coupled with a central part of the movable arm-set **3** in an adjustable way. More specifically, pin **25** is integral with a threaded dowel **26** that is in turn screwed into a first threaded end portion of an axial through hole **27** of the arm-set **3**. The through hole **27** has portions which have different diameter, among them a second threaded end portion, for the coupling of the arm **13**, and an intermediate threaded area that houses the body of a closure screw **28**. The head of the closure screw **28** compresses a ring shaped gasket (or "O-ring") **29** and seals the axial through hole **27**.

The part of the through hole **27** facing the interior of the probe, the space defined by the bellows **19**, the recess **22** and the longitudinal through hole (openings **34** and **35**) of the housing **33** of the microswitch **31** define a sealingly closed chamber that is full of a contact protecting fluid, more specifically nitrogen (N₂). Nitrogen, that is an inert gas, is inserted in the chamber through hole **27**, prior to sealing by means of screw **28** and O-ring **29**.

As previously mentioned, a probe according to the invention can foresee other embodiments of insofar as the mutual arrangement between movable arm-set **3** and casing **1** in the inoperative condition are concerned. As an alternative to the embodiment including some of the characteristics disclosed in patent No. US-A-5299360 (hereinafter referred to as "Probe A") with clearance between flange **11** and casing **1** in the inoperative condition, there can be foreseen an embodiment in which - in said inoperative condition - the abutment flange **11** rests on the abutment area **7** of the casing **1** (embodiment hereinafter referred to as "Probe B"). It should be noted that figure 1 wishes to represent both the embodiments (Probes A and B) wherein the clearances of some micrometers - existing in the first case between the abutment flange **11** and area **7** and in the second

- 10 -

case between the central portion **9** of the arm-set **3** and the seat **5** of the casing **1** - cannot be seen.

The operation of the probe according to the two embodiments is as follows.

5 When there is no contact between feeler **15** and piece **W** to be checked, the movable arm-set **3** is supported in casing **1** by the cone-ball type coupling existing between the portion **9** of the arm-set **3** and the seat **5** (Probe A), or between the abutment flange **11** and the abutment area **7** (Probe B) and
10 the end portions of mechanical body **63** face the small ball **51** and, respectively, the end part of the transmission pin **25**. At least one of the two elements (small ball **51** and pin **25**) is separate from the associated end of body **63** by an extremely limited amount of space, not shown in the figure
15 for the sake of simplicity. The electric circuit to which the conductive bars **44**, **45** and the small ball **51** belong is closed.

Further to mutual displacements between the probe and the piece **W**, and to contact between the feeler **15** and a surface
20 of the piece **W**, arm **13** and arm-set **3** displace integrally with respect to casing **1**.

In the event contact occurs between feeler **14** and piece **W** along a longitudinal direction (arrow **Z** in figure 1), in the case of both Probe A and Probe B there occurs a lifting
25 of the movable arm-set **3**, and more specifically of the end surface of the transmission pin **25**, with a substantially translation displacement. Conversely, in the case of contact occurring between feeler **15** and piece **W** along a transversal direction (arrow **X** in figure 1), in Probe A
30 there generally occurs a first, limited rotation of the arm-set **3** enabled by the cone-ball coupling, and the contact that is made substantially at a point between the annular surfaces of the flange **11** and of the area **7** causes a lifting (in other words a displacement including a
35 longitudinal component) of the end surface of the pin **25** further to a tilting of the arm-set **3** about said point of contact.

- 11 -

In the case of Probe B, contact between feeler **15** and piece **W** in the transversal direction **X** determines, in general, a first, limited translation of the arm-set **3** enabled by the clearance existing between the central portion **9** and the
5 seat **5**, and a subsequent displacing away of the annular surface of the flange **11** from the surface of the area **7**, the two surfaces maintaining contact substantially at a point about which the arm-set **3** tilts. In this case too, the tilting of the arm-set **3** causes a lifting (in other
10 words a displacement including a longitudinal component) of the end surface of the pin **25**.

In all the briefly described cases, the end surface of the pin **25** touches the spherical surface of the transmission element **67** and urges the mechanical body **63** that
15 longitudinally translates and is guided free of clearance by the cooperation between element **67** and binary **71**. The latter elements are held one against the other by the thrust of the spring **73** that also causes the transversal repeatable leaning of the stem **65** on a portion of the guide
20 surface of bushing **69**. Upon completion of a prestroke, the pushing stem **65** urges the small ball **51** to oppose the action of the spring **53** and to open the electric circuit. The opening of the circuit, that indicates the occurrence of contact between feeler **15** and piece **W**, is monitored in
25 the control and measurement detecting unit.

The longitudinal translation displacement of body **63**, in addition to being guided free of clearance as previously emphasized, is constrained by the coupling between the flat spring **73** and the substantially plane portion **77** of the
30 transmission element **67**. In fact, this coupling limits or rather prevents, in substance, rotations of body **63** about its axis. Consequently, there is the elimination of, or at least the considerable limitation of, errors due to the combined action, on the one hand of unavoidable although
35 minimum misalignments of the component parts of the microswitch **31** along the longitudinal axis (stem **65**, center of the small ball **51** and intermediate point between the

- 12 -

bars **44** and **45**), and on the other hand of shape, manufacturing or wear defects of the end surfaces of the body **63**. Similar shape defects could determine micrometric alterations with respect to the theoretical values of the distances existing between the end surfaces of the body **63** and, respectively, the small ball **51** and the transmission pin **25**. By preventing axial rotations of the body **63**, the values of said distances do not depend on the aforementioned misalignments and shape defects, and remain substantially unaltered in the course of the operation of the probe. In this way during the probe operation, the distance that the surface of pin **25** has to cover in order to cause, by urging the elongate body **63**, the detaching of the small ball **51** from the conductive bars **44** and **45** and so determine the opening of the circuit is substantially unchanged.

The result of all this is a considerable improvement in the repeatability characteristics of the probe.

As formerly mentioned, the housing **33** of the microswitch **31** is part of a sealingly closed chamber filled with nitrogen. This enables to keep the electrical contacts **44**, **45** and **51** in an environment substantially free from humidity and oxygen, so avoiding the negative effects due to oxidation and to guarantee a high standard of reliability of the probe that remains constant in time. On the other hand, nitrogen does not interfere with the metrological performances of the probe, contrarily to what occurs in known devices in which oily fluids are utilized to protect the contacts from oxidation.

It should be realized that, in a probe according to the present invention, it is possible to substitute nitrogen with a different fluid, more specifically a different inert gas as, for example, helium (He) or argon (Ar) and achieve identical results.

The insertion and, in general, the handling of an inert gas provide, moreover, considerable advantages with respect to the handling of oily fluids insofar as the prevention of

pollution in the environment is concerned, since inert gases result definitely "cleaner" and less troublesome to handle.

The manufacturing features of the probe, more specifically
5 insofar as the coupling among the various parts and the selection of the materials are concerned, can naturally differ with respect to the ones that are illustrated and hereinbefore described without departing from the scope of the present invention.

10 Moreover, the structure of the microswitch **31** can take other forms with respect to what has been hereinbefore illustrated and described. For example, there can be foreseen that only one of the bars **44** and **45** provides an electric contact, the other being made from non-conductive
15 material, while the small ball **51** is coupled to the conductors in the holes **55** for closing the electric circuit in an inoperative condition and for enabling to detect the opening of the circuit upon the release of the engagement between the small ball **51** and the conductive bar (**44** or
20 **45**).

Probes with just some of the advantageous characteristics herein described fall within the scope of this invention. More specifically, a probe with a microswitch that has a known structure (for example the one shown in figure 2 of
25 the previously mentioned patent No. US-A-5299360), in which suitable elements guarantee the sealing of a chamber including the internal area of the microswitch with the electric contacts and said chamber is filled with nitrogen or other inert gas, falls within the scope of the invention
30 too.

Probes utilizing similar electric-switch detecting devices also fall within the scope of the invention even if they have important structural differences with respect to the embodiments of figure 1 (Probe A and Probe B) that can
35 regard, for example, the support of the arm-set **3** in casing **1**.

CLAIMS

1. A touch probe, including
- a casing **(1)** that defines a longitudinal geometric axis,
 - 5 • a movable arm-set **(3)** housed in the casing **(1)**,
 - an arm **(13)** rigidly coupled to the movable arm-set **(3)**,
with an end extending out of the casing,
 - a feeler **(15)** coupled to said end of the arm **(13)**, and
 - an electric switch **(31)** adapted for detecting
 - 10 displacements of the movable arm-set **(3)** with respect to
the casing **(1)**, and including
 - at least a stationary contact **(44,45)** and a movable
contact **(51)**,
 - a housing **(33)** enclosing said stationary contact **(44,45)**
 - 15 and said movable contact **(51)** and a contact protective
fluid, and
 - a mechanical transmission device **(61)** adapted for
transmitting displacements of the movable arm-set **(3)** to
 - 20 the movable contact **(51)**,
- characterized in that
said protective fluid is an inert gas.
2. The probe according to claim 1, wherein said inert gas
is nitrogen.
- 25
3. The probe according to claim 1 or claim 2, wherein the
casing **(1)** encloses a sealingly closed chamber
(19,22,34,35), the housing **(33)** of the electric switch **(31)**
lying at the interior of said sealingly closed chamber
- 30 **(19,22,34,35)**, the inert gas being present in the sealingly
closed chamber **(19,22,34,35)**.
4. The probe according to claim 3, including an
antirotation device adapted for preventing rotations of the
- 35 movable arm-set **(3)** with respect to the casing **(1)** about a
longitudinal axis, said antirotation device including a
metal bellows **(19)** fixed to the ends of the movable arm-set

(3) and to a mechanical coupling element (20), rigidly coupled to the casing (1), the metal bellows (19) defining at least in part said sealingly closed chamber (19,22,34,35).

5

5. The probe according to claim 3 or claim 4, wherein the movable arm-set (3) defines an axial through hole (27) communicating with said sealingly closed chamber (19,22,34,35), the inert gas being inserted in the sealingly closed chamber (19,22,34,35) through said axial through hole (27).

6. The probe according to claim 5, further including a closure screw (28) and a ring gasket (29), wherein the axial through hole (27) includes at least a threaded area, the closure screw (28) being adapted to be coupled to said at least one threaded area and to lock the ring gasket (29) for achieving the sealing of the axial through hole (27).

7. The probe according to one of the claims 1 to 6, wherein the mechanical transmission device (61) of the electric switch (31) includes an elongate mechanical body (63) between the movable arm-set (3) and the movable contact (51), substantially longitudinal guide surfaces (70-72) and an elastic thrust element (73) adapted for urging the elongate mechanical body (63) against said guide surfaces (70-72).

8. The probe according to claim 7, wherein the elastic thrust device includes a bent flat spring (73) and the elongate mechanical body (63) includes a transmission element (67) with a substantially spherical shape adapted for cooperating with the substantially longitudinal guide surfaces (70-72) urged by the bent flat spring (73), the transmission element (67) including a substantially plane portion (77) adapted for cooperating with said bent flat spring (73).

- 16 -

9. The probe according to one of the claims from 1 to 8, wherein the movable arm-set **(3)** is supported in the casing **(1)** by means of a cone-ball coupling **(9,5)**, the movable
5 arm-set and the casing defining annular surfaces **(7,11)** adapted to mutually contact and to cause, further to displacements of the arm **(13)**, longitudinal displacements of the movable arm-set **(3)** suitable for being transmitted, by means of said mechanical transmission device **(61)**, to
10 the movable contact **(51)** of the electric switch **(31)**.

10. The probe according to one of the claims from 1 to 8, wherein the movable arm-set **(3)** is supported in the casing **(1)** by a coupling between plane annular surfaces **(7,11)**,
15 the movable arm-set **(3)** and the casing **(1)** defining, respectively, a substantially spherical portion **(9)** and a substantially frusto-conical seat **(5)** adapted to mutually contact and to cause, further to displacements of the arm **(13)**, the partial disengagement between the plane annular
20 surfaces **(7,11)** and the consequent longitudinal displacements of the movable arm-set **(3)** suitable for being transmitted, by means of said mechanical transmission device **(61)**, to the movable contact **(51)** of the electric switch **(31)**.

25
11. The probe according to one of the claims from 1 to 10, wherein the electric switch **(31)** includes a spring **(53)** for urging the movable contact **(51)** against said at least one stationary contact **(44,45)**.

30
12. The probe according to claim 11, wherein said electric switch **(31)** includes at least two stationary contacts **(44,45)**, said spring **(53)** being adapted for urging the movable contact **(51)** against the two stationary contacts
35 **(44,45)**.

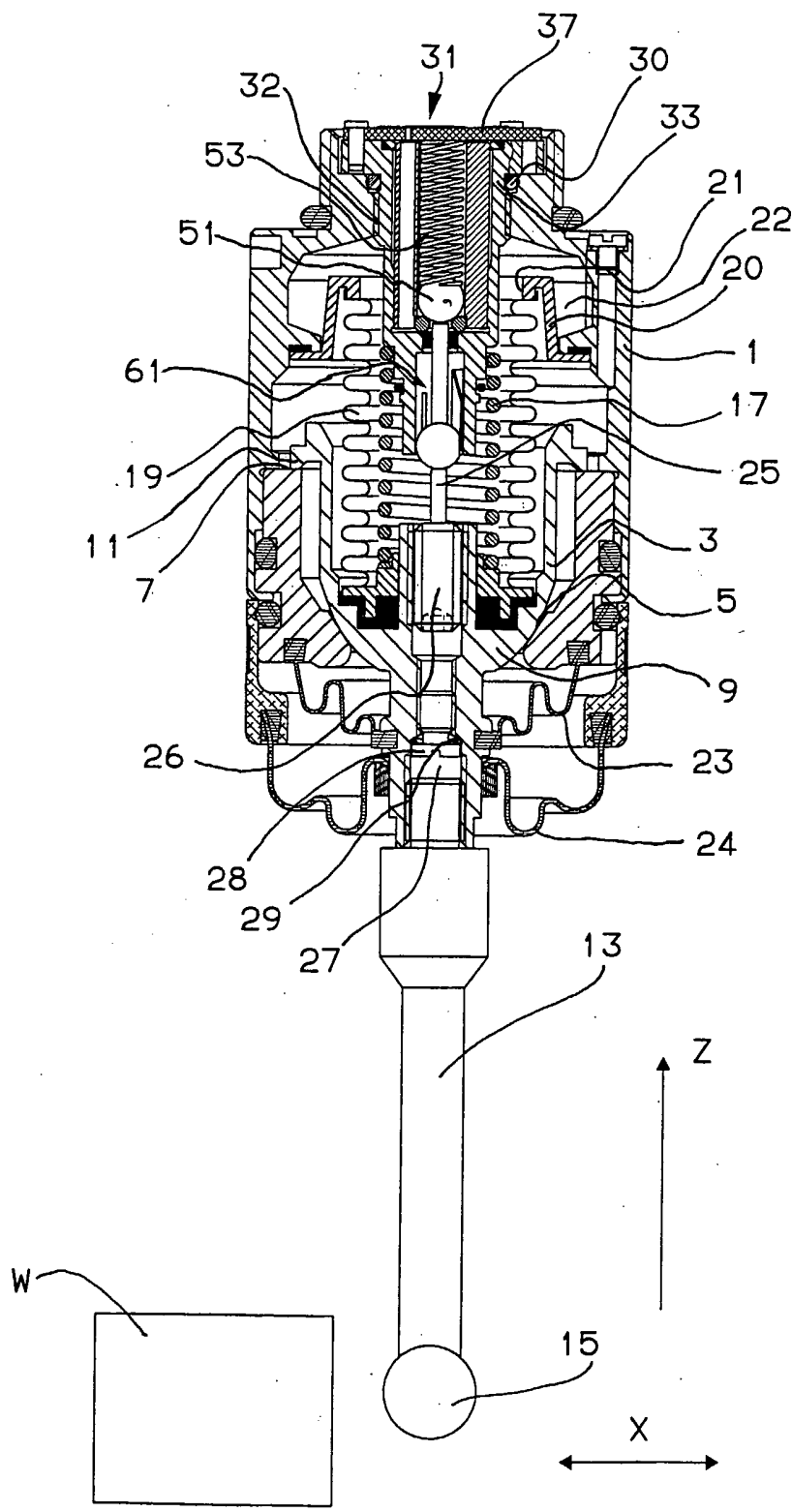

Fig. 1

2 / 2

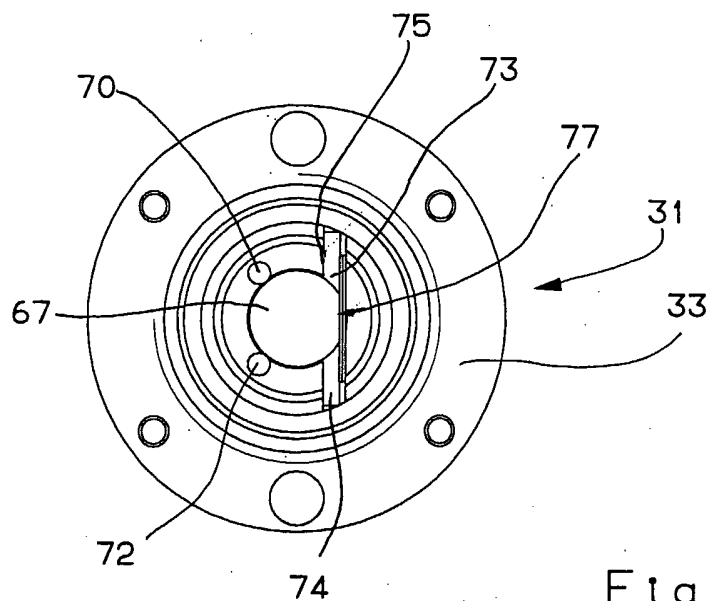

Fig. 3

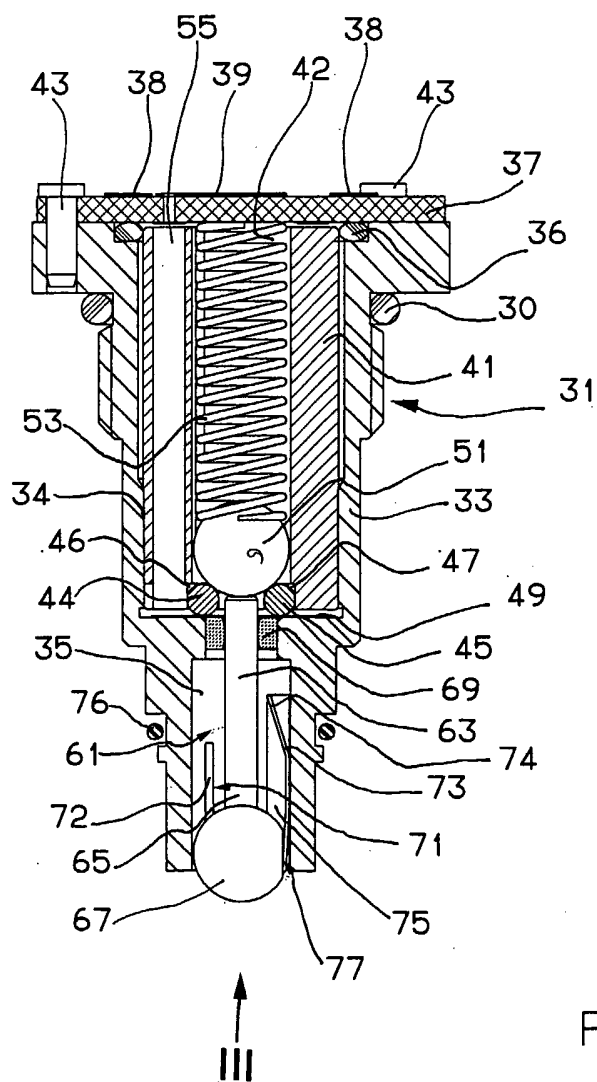

Fig. 2

INTERNATIONAL SEARCH REPORT

International Application No

PCT/EP 03/10805

A. CLASSIFICATION OF SUBJECT MATTER
 IPC 7 G01B5/012 G01B7/012

According to International Patent Classification (IPC) or to both national classification and IPC

B. FIELDS SEARCHED

Minimum documentation searched (classification system followed by classification symbols)

IPC 7 G01B H01H

Documentation searched other than minimum documentation to the extent that such documents are included in the fields searched

Electronic data base consulted during the international search (name of data base and, where practical, search terms used)

EPO-Internal, WPI Data, PAJ

C. DOCUMENTS CONSIDERED TO BE RELEVANT

Category *	Citation of document, with indication, where appropriate, of the relevant passages	Relevant to claim No.
X	US 4 577 416 A (FRANZ WIESNER) 25 March 1986 (1986-03-25) column 1, line 33 -column 4, line 63; figure 1 ---	1-6,9-12
A	WO 00 17602 A (MARPOSS APP ELETT ;DANIELLI FRANCO (IT); BARUCHELLO ROBERTO (IT)) 30 March 2000 (2000-03-30) page 4, line 19 -page 7, line 2 ---	1-12
A	US 5 299 360 A (POSSATI DECEASED MARIO ET AL) 5 April 1994 (1994-04-05) cited in the application column 3, line 42 -column 6, line 59; figures 1,2 --- -/--	1-12

Further documents are listed in the continuation of box C. Patent family members are listed in annex.

- | | |
|--|---|
| <p>* Special categories of cited documents :</p> <ul style="list-style-type: none"> *A* document defining the general state of the art which is not considered to be of particular relevance *E* earlier document but published on or after the international filing date *L* document which may throw doubts on priority claim(s) or which is cited to establish the publication date of another citation or other special reason (as specified) *O* document referring to an oral disclosure, use, exhibition or other means *P* document published prior to the international filing date but later than the priority date claimed | <ul style="list-style-type: none"> *T* later document published after the international filing date or priority date and not in conflict with the application but cited to understand the principle or theory underlying the invention *X* document of particular relevance; the claimed invention cannot be considered novel or cannot be considered to involve an inventive step when the document is taken alone *Y* document of particular relevance; the claimed invention cannot be considered to involve an inventive step when the document is combined with one or more other such documents, such combination being obvious to a person skilled in the art. *&* document member of the same patent family |
|--|---|

Date of the actual completion of the international search	Date of mailing of the international search report
26 January 2004	05/02/2004

Name and mailing address of the ISA European Patent Office, P.B. 5818 Patentlaan 2 NL - 2280 HV Rijswijk Tel. (+31-70) 340-2040, Tx. 31 651 epo nl, Fax: (+31-70) 340-3016	Authorized officer Beyfuß, M
--	-------------------------------------

INTERNATIONAL SEARCH REPORT

International Application No

PCT/EP 03/10805

C.(Continuation) DOCUMENTS CONSIDERED TO BE RELEVANT		
Category °	Citation of document, with indication, where appropriate, of the relevant passages	Relevant to claim No.
A	GB 2 145 523 A (GTE VALERON CORP) 27 March 1985 (1985-03-27) page 1, line 69-96 ---	1-12
A	US 5 319 858 A (COY JOANNE) 14 June 1994 (1994-06-14) column 3, line 16-45 ---	1-12
A	US 4 789 762 A (MILLER JAMES R ET AL) 6 December 1988 (1988-12-06) column 4, line 1-13; figures 1-3 -----	1-12

INTERNATIONAL SEARCH REPORT

Information on patent family members

International Application No

PCT/EP 03/10805

Patent document cited in search report	A	Publication date	Patent family member(s)	Publication date
US 4577416	A	25-03-1986	AT 32261 T BR 8307598 A DE 3246252 A1 DE 3375507 D1 WO 8401820 A1 EP 0110192 A1	15-02-1988 02-10-1984 28-06-1984 03-03-1988 10-05-1984 13-06-1984
WO 0017602	A	30-03-2000	IT B0980538 A1 AT 233395 T AU 5625299 A DE 69905593 D1 DE 69905593 T2 WO 0017602 A1 EP 1116006 A1 ES 2191454 T3 US 6526672 B1	21-03-2000 15-03-2003 10-04-2000 03-04-2003 27-11-2003 30-03-2000 18-07-2001 01-09-2003 04-03-2003
US 5299360	A	05-04-1994	IT 1238266 B BR 9104823 A DE 69102035 D1 DE 69102035 T2 EP 0476076 A1 JP 7056441 B JP 4505217 T KR 9509066 B1 WO 9114149 A1 ES 2054491 T3	12-07-1993 24-03-1992 23-06-1994 01-09-1994 25-03-1992 14-06-1995 10-09-1992 14-08-1995 19-09-1991 01-08-1994
GB 2145523	A	27-03-1985	BE 900428 A1 DE 3431476 A1 IT 1237348 B JP 60091201 A SE 8404219 A	17-12-1984 07-03-1985 31-05-1993 22-05-1985 27-02-1985
US 5319858	A	14-06-1994	DE 69120658 D1 DE 69120658 T2 EP 0512094 A1 WO 9209862 A1 JP 7117363 B JP 5509410 T	08-08-1996 31-10-1996 11-11-1992 11-06-1992 18-12-1995 22-12-1993
US 4789762	A	06-12-1988	NONE	