

June 25, 1929.

D. W. GREENE
PORTABLE LIGHTER

1,718,902

Filed Feb. 18, 1928

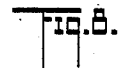
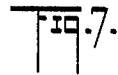
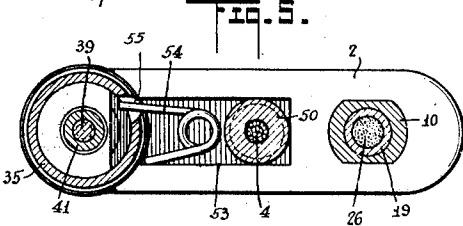
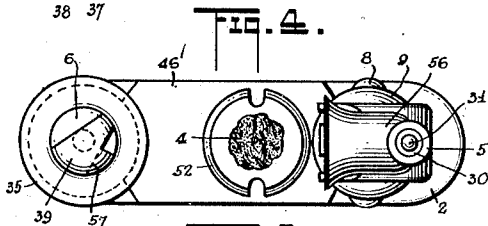
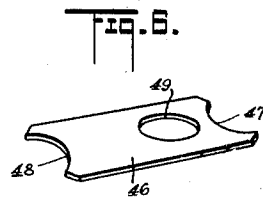
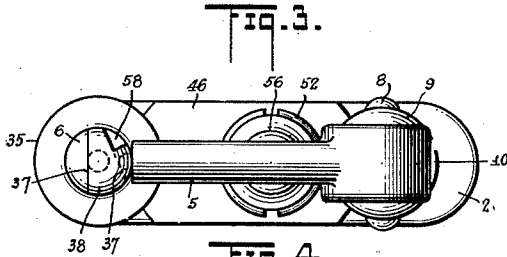
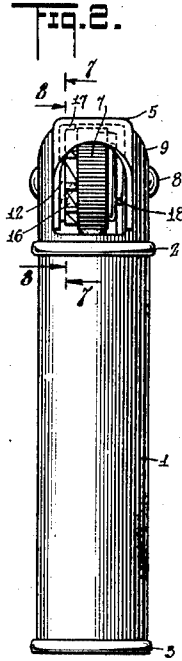
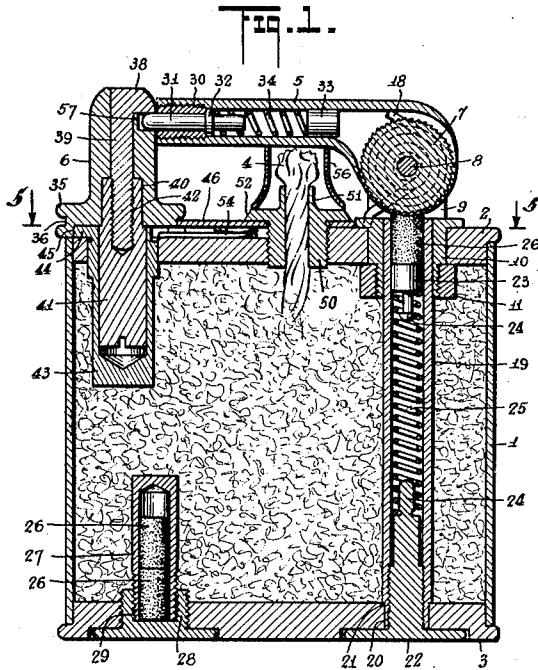

WITNESSES

Frank J. Poggiani
L. W. Foster

INVENTOR
David W. Greene.
BY *Wm. H. K.*
ATTORNEY

UNITED STATES PATENT OFFICE.

DAVID W. GREENE, OF NEW YORK, N. Y., ASSIGNOR TO M. E. BERNHARDT COMPANY, INC., OF NEW YORK, N. Y., A CORPORATION OF NEW YORK.

PORTABLE LIGHTER.

Application filed February 18, 1928. Serial No. 255,354.

This invention relates to portable lighters, an object of the invention being to provide a portable lighter in which the several parts may be conveniently assembled, and worn or injured parts readily replaced.

A further object is to provide a lighter of this character in which a spring moved, spark throwing arm is held in inactive position by an improved construction and arrangement of post, having a partial turning movement to release the arm and permit the latter to throw sparks and ignite a wick.

This particular invention has more particularly to do with the details of construction and their assemblage to produce an efficient mechanical device which is not liable to get out of order and which will most efficiently perform the functions for which it is intended.

With these and other objects in view, the invention consists in certain novel features of construction and combinations and arrangements of parts, which will be more fully hereinafter described and pointed out in the claims.

In the accompanying drawings—

Figure 1 is a view in vertical longitudinal section through my improved lighter, showing the spark throwing arm in set or inactive position;

Figure 2 is an end view, looking at the right-hand end of Figure 1;

Figure 3 is a top plan view of Figure 1;

Figure 4 is a top plan view showing the spark throwing arm released and in upright position;

Figure 5 is a view in horizontal section on the line 5—5 of Figure 1;

Figure 6 is a perspective view of the plate 46;

Figure 7 is a view in side elevation of my improved pawl disk 12, the view of the disk being taken on the line 7—7 of Figure 2;

Figure 8 is a view in side elevation of the spark throwing wheel 7, the view of the wheel being taken on the line 8—8 of Figure 2.

1 represents the casing of my improved lighter having top and bottom plates 2 and 3 secured thereto and forming a container for fuel oil to maintain a wick 4, saturated for ignition. The top plate 2 supports a spark throwing arm 5 and a post 6, which latter functions to hold the arm in inactive position and release the arm to ignite the wick.

The arm 5 above referred to may be stamped from sheet metal or otherwise formed so that the major portion of said arm is tubular, but one end of said arm is fork-shaped or bifurcated to receive a toothed spark throwing wheel 7 therein, and the arm 5 and the wheel 7 have pivotal and partial rotary mounting on a pin 8 which is projected through alined openings in the forked end of the arm, through the wheel 7, and through the members of a supporting fork 9.

This fork 9 has a somewhat angular base portion 10 projecting through an opening in the top plate 2, and the lower extremity of this base portion 10 is externally screw-threaded to receive a nut 11 which secures the fork rigidly to the top plate.

A pawl disk 12 of spring metal is positioned beside the wheel 7 and has a central opening 13 to receive the pin 8, and has a slit 14 extending radially from the opening 12, and the metal constituting one wall of said slit is flared outwardly, forming a pawl 15 which engages in recesses 16 in the side face of the wheel 7. The disk 12 also has an angle arm extension 17 which engages under the arm 5 so as to compel the disk to turn with the arm.

It is of course to be understood that the recesses 16 and pawl 15 constitute a ratchet coupling means between the arm and the wheel 7 so that when the arm swings upwardly the wheel is caused to turn with the arm, and when the arm is swung downwardly the pawl 15 will ride over the face of the wheel without turning the same.

A coiled spring 18 is located within the bifurcated or forked end of arm 5 and at one end engages said arm and at the other end engages the base portion 10 of fork 9 so that this spring tends always to throw the arm to an upright position.

The base portion 10 of fork 9 is tubular in form and receives a tube 19, this tube having a reduced end 20 located in an opening in the bottom plate 3 with the shoulder 21 formed by said reduced end resting against the inner face of plate 3 so as to hold the parts in proper assemblage.

A screw 22 is screwed into the lower end of the tube 19 and countersunk in the bottom plate 3 and a follower 23 fits the tube and is movable therein. This follower 23 and the screw 22 have headed pins 24 thereon on which a coiled spring 25 is set. This coiled

spring exerts upward pressure on the follower 23, pressing a stone or block of pyrophoric alloy 26 against the face of the toothed wheel 7.

5 In the bottom plate 3 I also locate a removable tubular casing 27, which acts as a container for a supply of blocks of alloy 26. This tubular container at its open lower end has screw-threaded engagement with a capped screw 28 and the latter is screwed into a threaded opening 29 in the bottom plate 3 with the head of the screw countersunk, as clearly shown in Figure 1, so that this casing 27 may be removed and new blocks of stone 15 or alloy supplied as the other stones are worn or used up.

As above stated, the major portion of the arm 5 is tubular in form, and in this tubular portion, which constitutes the free end of the arm, a bushing 30 is screwed and provides mounting for a catch pin 31. This catch pin 31 projects beyond the end of the bushing and the arm and is preferably rounded or beveled, as shown at its outer extremity, and adjacent its inner end is formed with an annular shoulder 32 adapted to engage the inner end of bushing 30.

A block 33 is fixed in the arm 5 and a coiled spring 34 is interposed between the block 33 and the shoulder 32 of pin 31 so as to exert pressure on the pin, normally projecting the end of the pin beyond the end of the arm, as shown in Figure 2.

The post 6 above referred to, which normally holds the arm 5 in inactive or horizontal position, has a circular base portion 35 which is preferably milled or otherwise roughened so as to permit the same to be readily turned by the engagement of a finger therewith, and this base portion 35 has an annular groove 36 therein for a purpose which will hereinafter appear.

The upper end of the post 6 is made with a recess 37 to receive and accommodate the head 38 of a pin 39. The post 6 has a longitudinal bore accommodating the pin 39, and the base portion of said post has a recess 40 therein receiving the upper reduced end of a journal pin 41, and said journal pin 41 has a screw-threaded recess 42 in its upper end in which the screw threaded lower end of the pin 39 is secured.

The journal pin 41 has rotary or partial movement in a cylindrical bearing cup 43 projected into the casing 1 through an opening in the top plate 2, and this bearing cup 43 has an annular flange 44 at its upper end resting within a recess 45 in the base of post 6 and also in a suitable recess in the top plate 2.

The post assemblage, indicated generally by the reference character 6, and including the post per se, pin 39 and the journal pin 41, turns as an entirety and is held against longitudinal displacement by means of a

plate 46. This plate 46 has a recess 47 at one end bearing against the upper end of the base portion 10 of fork 9, and at its other end has a curved recess 48, and this recessed end 48 projects into the annular groove 36 in the base portion 35 of post 6.

The plate 46 also has an opening 49 therein through which a threaded nipple 50 of a tubular wick holder 51 is projected. This wick holder 51 supports the wick 4 above referred to and has a disk-like spanner receiving enlargement 52 thereon which rests upon the plate 46, and, when the nipple 50 is screwed into the opening in the top plate 2 provided for the purpose, the wick holder will serve to secure the plate 46 against displacement.

The top plate 2 has a recess 53 therein accommodating a spring 54, one end of said spring bearing against a wall of the recess, and the other end of said spring projecting into a notch 55 in the base 35 of post 6, holding said post in normal position and adapted to return said post to normal position.

The arm 5 carries a cup or snuffer 56 which is adapted to cover the wick 4 and extinguish the same when the arm is moved to horizontal position.

Referring again to the post assemblage in Figure 1, it will be noted that the post has a recess 57 under the head 38 of pin 39 and that the latch pin 31 normally rests in this recess 57 to hold the arm in horizontal position. The recess 57, indicated in full lines in Figure 1 and in dotted lines in Figures 3 and 4, is located directly under the head 38, and said head 38 has a recess 58 therein which registers with one end of recess 57, but said recess 58 is normally out of vertical alinement with the pin 31 so that in order to release the arm 5 and allow it to function it is necessary to impart a partial turning movement to the post assemblage to bring the recess 58 into register with the end of pin 31, allowing the arm to swing upwardly and throw sparks to ignite the wick. When the post is released it will return to normal position and when the arm is swung downwardly the pin 31 will ride over the head 38 into the recess 57 and be held in inactive position.

By reason of this construction of post assemblage I am enabled to employ a pin 39 having a head 38 which may be case hardened or otherwise rendered extremely hard to withstand the wear to which it is subjected as it is of course to be understood that the head of the pin constitutes a rounded or beveled surface against which the latch pin 31 rides into its holding position, and there is necessarily a maximum of wear at this point and it is therefore desirable that the pin 39 be such that it will withstand the wear, and if it should wear it can be replaced at a very small cost.

It is to be noted that the different parts of my improved device while capable of ready

assemblage into a complete whole are equally capable of removal and replacement in the event of wear or injury, and I therefore believe that I have produced a device which is not only most efficient in its performance but is also as near mechanically perfect in design as it is possible to make the same, so that replacement can be furnished and the life of the device as a whole can be extended almost without limit.

Various changes and alterations might be made in the general form of the parts described without departing from my invention and hence I do not limit myself to the precise details set forth but consider myself at liberty to make such changes and alterations as fairly fall within the spirit and scope of the appended claims:

I claim:

1. A portable lighter, including a casing, a wick supported by the casing, a pivoted spring pressed spark throwing arm, an abrader adapted to rotate with said arm, means for pressing a pyrophoric substance into operative engagement with said abrader to throw sparks when the arm swings in one direction, a post having partial rotary mounting on the casing, and a removable pin in the post having a head thereon under which the free end of the arm is adapted to be operatively engaged to hold the arm in inactive position.

2. A portable lighter, including a casing, a wick supported by the casing, a pivoted spring pressed spark throwing arm, an abrader adapted to rotate with said arm, means for pressing a pyrophoric substance into operative engagement with said abrader to throw sparks when the arm swings in one direction, a post having partial rotary mounting on the casing, a removable pin in the post having a head thereon under which the free end of the arm is adapted to be operatively engaged to hold the arm in inactive position, said post having a recess under said head, and a spring pressed latch pin in the arm adapted to engage in said recess.

3. A portable lighter, including a casing, a wick supported by the casing, a pivoted spring pressed spark throwing arm, an abrader adapted to rotate with said arm, means for pressing a pyrophoric substance into operative engagement with said abrader to throw sparks when the arm swings in one direction, a post having partial rotary mounting on the casing, and a removable pin in the post having a head thereon under which the free end of the arm is adapted to be operatively engaged to hold the arm in inactive position, said head having a notch or recess therein adapted when the post is turned to one position to permit the release of the arm.

4. A portable lighter, including a casing,

a wick supported by the casing, a pivoted spring pressed spark throwing arm, an abrader adapted to rotate with said arm, means for pressing a pyrophoric substance into operative engagement with said abrader to throw sparks when the arm swings in one direction, a post having partial rotary mounting in the casing, a removable pin in the post having a head thereon under which the free end of the arm is adapted to be operatively engaged to hold the arm in inactive position, said post having a recess under said head, and a spring pressed latch pin in the arm adapted to engage in said recess, said head having a notch or recess therein adapted when the post is turned to one position to permit the release of the arm.

5. A portable lighter, including a casing, a wick supported in the casing, a pivoted spring pressed spark throwing arm, an abrader adapted to rotate with said arm, means for pressing a pyrophoric substance into operative engagement with said abrader to throw sparks when the arm swings in one direction, a post having partial rotary mounting on the casing, a removable pin in the post having a head thereon under which the free end of the arm is adapted to be operatively engaged to hold the arm in inactive position, said post having an annularly grooved base portion, a plate secured on the casing and projecting into said groove, and a spring under the plate operatively engaging the post to hold the same in normal position.

6. A portable lighter, including a casing, a wick supported by the casing, a pivoted spring pressed spark throwing arm, an abrader adapted to rotate with said arm, means for pressing a pyrophoric substance into operative engagement with said abrader to throw sparks when the arm swings in one direction, a post having partial rotary mounting on the casing, a removable pin in the post having a head thereon under which the free end of the arm is adapted to be operatively engaged to hold the arm in inactive position, said post having a recess under said head, a spring pressed latch pin in the arm adapted to engage in said recess, said post having an annularly grooved base portion, a plate secured on the casing and projecting into said groove, and a spring under the plate operatively engaging the post to hold the same in normal position.

7. A portable lighter, including a casing, a wick supported by the casing, a pivoted spring pressed spark throwing arm, an abrader adapted to rotate with said arm, means for pressing a pyrophoric substance into operative engagement with said abrader to throw sparks when the arm swings in one direction, a post having partially rotary mounting on the casing, a removable pin in

the post having a head thereon under which the free end of the arm is adapted to be operatively engaged to hold the arm in inactive position, said head having a notch or recess therein adapted when the post is turned to one position to permit the release of the arm, said post having an annularly grooved base portion, a plate secured on the casing and projecting into said groove, and a spring under the plate operatively engaging the post to hold the same in normal position.

8. A portable lighter, including a casing, a wick supported by the casing, a pivoted spring pressed spark throwing arm, an abrader adapted to rotate with said arm, means for pressing a pyrophoric substance into operative engagement with said abrader to throw sparks when the arm swings in one direction, a post having partial rotary mounting in the casing, a removable pin in the post having a head thereon under which the free end of the arm is adapted to be operatively engaged to hold the arm in inactive position, said post having a recess under said head, a spring pressed latch pin in the arm adapted to engage in said recess, said head having a notch or recess therein adapted when the post is turned to one position to permit the release of the arm, said post having an annularly grooved base portion, a plate secured on the casing and projecting into said groove, and a spring under the plate operatively engaging the post to hold the same in normal position.

9. A lighter, including a casing, a wick supported in the casing and projecting therefrom, a spark throwing pivoted arm mounted on the casing, a snuffer on said arm adapted to be positioned over the wick, a tube mounted in the casing and adapted to contain a pyrophoric substance engaged by the spark throwing arm, a spring in said casing exerting pressure on the pyrophoric substance, a turning post adapted to hold the arm inactive, a cup bearing secured in the casing, a journal secured to the post and mounted in the cup bearing, and a removable plate operatively engaging the post and holding the journal in the bearing.

10. A lighter, including a casing, a wick supported in the casing and projecting therefrom, a spark throwing pivoted arm mounted on the casing, a snuffer on said arm adapted to

be positioned over the wick, a tube mounted in the casing and adapted to contain a pyrophoric substance engaged by the spark throwing arm, a spring in said casing exerting pressure on the pyrophoric substance, a turning post adapted to hold the arm inactive, a cup bearing secured in the casing, a journal secured to the post and mounted in the cup bearing, a removable plate operatively engaging the post and holding the journal in the bearing, and a removable screw-threaded wick tube screwed into the casing and holding the plate in position.

11. A lighter, including a casing, a wick supported in the casing and projecting therefrom, a spark throwing pivoted arm mounted on the casing, a snuffer on said arm adapted to be positioned over the wick, a tube mounted in the casing and adapted to contain a pyrophoric substance engaged by the spark throwing arm, a spring in said casing exerting pressure on the pyrophoric substance, a turning post adapted to hold the arm inactive, a cup bearing secured in the casing, a journal secured to the post and mounted in the cup bearing, a removable plate operatively engaging the post and holding the journal in the bearing, and a spring under the said plate operatively engaging the post.

12. A lighter, including a casing, a wick supported in the casing and projecting therefrom, a spark throwing pivoted arm mounted on the casing, a snuffer on said arm adapted to be positioned over the wick, a tube mounted in the casing and adapted to contain a pyrophoric substance engaged by the spark throwing arm, a spring in said casing exerting pressure on the pyrophoric substance, a turning post adapted to hold the arm inactive, a cup bearing secured in the casing, a journal secured to the post and mounted in the cup bearing, a removable plate operatively engaging the post and holding the journal in the bearing, a removable screw-threaded wick tube screwed into the casing and holding the plate in position, and a spring under said plate operatively engaging the post.

Signed at New York in the county of New York and State of New York this 17th day of February A. D. 1928.

DAVID W. GREENE.