

(19) World Intellectual Property Organization
International Bureau



(43) International Publication Date
22 March 2001 (22.03.2001)

PCT

(10) International Publication Number
WO 01/19270 A1

- (51) International Patent Classification⁷: **A61B 18/18**
- (21) International Application Number: PCT/US00/24836
- (22) International Filing Date:
11 September 2000 (11.09.2000)
- (25) Filing Language: English
- (26) Publication Language: English
- (30) Priority Data:
09/396,959 15 September 1999 (15.09.1999) US
09/539,056 30 March 2000 (30.03.2000) US
- (71) Applicant: **THE GENERAL HOSPITAL CORPORATION** doing business as **MASSACHUSETTS GENERAL HOSPITAL** [US/US]; 55 Fruit Street, Boston, MA 02114 (US).
- (72) Inventor: **KEANE, David**; 51 Woodside Avenue, Wellesley, MA 02462 (US).
- (74) Agents: **GEARY, William, C., III** et al.; Nutter, McClenen & Fish, LLP, One International Place, Boston, MA 02110-2699 (US).
- (81) Designated States (*national*): CA, JP.
- (84) Designated States (*regional*): European patent (AT, BE, CH, CY, DE, DK, ES, FI, FR, GB, GR, IE, IT, LU, MC, NL, PT, SE).
- Published:**
— *With international search report.*
- For two-letter codes and other abbreviations, refer to the "Guidance Notes on Codes and Abbreviations" appearing at the beginning of each regular issue of the PCT Gazette.*

(54) Title: COILED ABLATION CATHETER SYSTEM

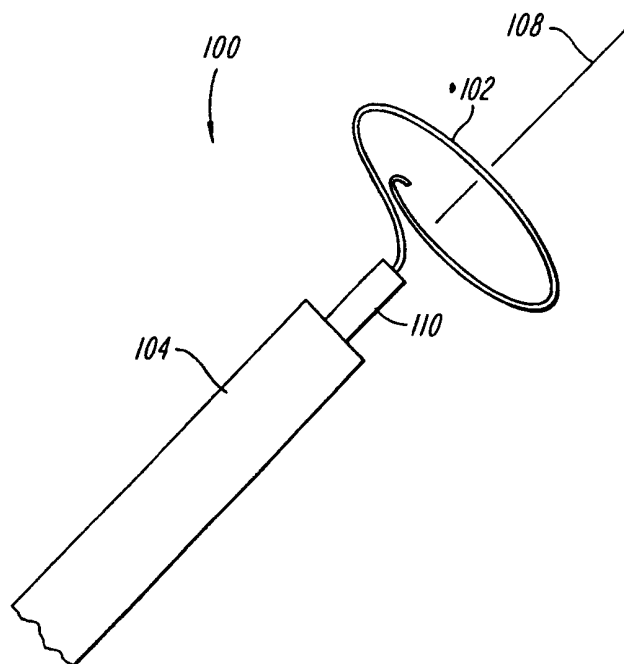

(57) Abstract: A cardiac ablation catheter (100) includes a coil-like ablating element (102) that is deployed from an elongate, flexible sheath (104). The ablating element (102), while in the deployed position, has a shape with at least one revolution oriented in a plane that is orthogonal to a longitudinal axis (108) of the sheath. The catheter system (100) is well-suited to ablate a circumferential region of tissue about a pulmonary vein or the posterior wall of the left atrium proximate the pulmonary vein os. The treated tissue region electrically isolates the atria from the pulmonary vein.



WO 01/19270 A1

COILED ABLATION CATHETER SYSTEM

FIELD OF THE INVENTION

5 The present invention relates generally to catheter systems, and more particularly, to catheter systems for ablating and/or isolating foci that contribute to cardiac arrhythmia.

BACKGROUND OF THE INVENTION

10 Catheters are commonly used in surgical procedures to access certain areas of a patient's body without resorting to invasive surgical procedures. For example, catheters are widely used in the field of cardiology to conduct electrophysiological studies in which electrical potentials within the heart are mapped to determine the cause and location of arrhythmia. In many cases, certain undesired conductive pathways, known as foci, contribute to and cause the arrhythmia. Once the location of foci is
15 identified, elements on or within the catheter can be utilized to ablate or isolate the foci, thus eliminating the arrhythmia.

One form of arrhythmia is atrial fibrillation, which is an uncoordinated contraction of the heart muscle within the atrium. Atrial fibrillation results from rapidly discharging foci and causes irregular heart beats, possibly leading to inefficient
20 pumping of blood. In a significant number of patients, the foci that contribute to this condition are located within the pulmonary vein, adjacent to the atrium. These foci may be in the form of scattered groups of rapidly discharging cells. Treatment of this condition can sometimes be effective through the ablation of these foci. However, identifying the location of these foci and effecting the ablative treatment of the foci can
25 be time consuming and difficult.

A variety of cardiac mapping and ablation catheter systems are well known in the art. For example, U.S. Patent No. 5,476,495 (Kordis et al.) discloses a steerable catheter system that is able to conduct cardiac mapping and ablation. U.S. Patent No. 5,507,743 (Edwards et al.) discloses a radio frequency (RF) treatment apparatus that
30 includes a RF electrode that assumes a helical orientation upon deployment. U.S.

Patent No. 5,738,683 (Osypka) discloses a cardiac mapping/ablation catheter that includes an electrode that may be deployed in the shape of a loop. U.S. Patent No. 5,782,879 (Imran) discloses an endocardial mapping and ablation system in which the catheter includes a deployable distal extremity, in the form of a cage-like member that includes a plurality of electrodes.

Despite the existence of these references and existing ablation catheter systems, there exists a need to provide a system that is able to effectively treat atrial fibrillation conditions that are caused by foci present within the pulmonary vein.

SUMMARY OF THE INVENTION

The present invention provides a cardiac catheter system for ablating tissue to electrically isolate certain tissue from arrhythmia-inducing foci. Although the invention is primarily shown and described as a cardiac catheter system for ablating tissue with RF energy, it is understood that the system has other applications and embodiments as well. For example, other types of energy, such as microwave, laser, cryogenic, and ultrasonic energy, can be used without departing from the scope of the invention.

In one embodiment, a cardiac ablation catheter system includes an elongate, flexible sheath having an internal lumen and an open distal end. An ablating element is disposed within the sheath and is selectively deployable therefrom so as to project from the sheath in a substantially coil-like shape. In an exemplary embodiment, the deployed ablating element has a geometry forming at least one revolution for generating a circumferential lesion within a vessel, such as a pulmonary vein. In general, the ablating element is oriented in a plane that is substantially orthogonal to the longitudinal axis of the sheath in the deployed position to facilitate the formation of a lesion about the vein inner wall circumference.

The catheter system can include a variety of mechanisms for deploying the ablation member from the catheter. In one embodiment, the ablation member is released from a distal end of the catheter such that it assumes a predetermined shape. In another embodiment, the catheter includes a hatch or port from which the ablation member is selectively deployed. In a further embodiment, the elongate member includes a distal end

affixed to a support member that is extendable from the catheter distal end. By rotating and/or longitudinally displacing the support member, the ablation member can be deployed such it assumes a desired size.

5 To ablate or isolate the target foci tissue, the catheter is manipulated through the arterial network until the catheter is located proximate the desired treatment site. For example, the treatment site may be a location within the pulmonary vein or left atrium at or near the pulmonary vein os or in the right ventricular outflow tract, such as at the junction of the right atrium and superior vena cava. The ablating element is then
10 deployed from the catheter such that the coil-like ablating element is generally oriented in a plane orthogonal to the longitudinal axis of the sheath. The deployed ablating element should be in contact with tissue about the circumference of the vein inner wall, such as at the os. The ablation element is then energized to ablate the target tissue to electrically isolate the foci from healthy tissue on the opposite side of the formed lesion. The atria, for example, can be electrically isolated from a treated pulmonary vein by creating a
15 circumferential lesion on the inner wall of the left atrium or in the pulmonary vein proximate the os.

BRIEF DESCRIPTION OF THE DRAWINGS

20 The invention will be more fully understood from the following detailed description taken in conjunction with the accompanying drawings, in which:

FIG. 1 is a perspective view of an ablation catheter system in accordance with the present invention;

FIG. 2 is a side view of a portion of the catheter system of FIG. 1;

FIG. 3 is a front view of a portion of the catheter system of FIG. 1;

25 FIG. 4 is a pictorial representation of the orientation of an ablating element in a deployed position and a catheter that forms a part of the catheter system of FIG. 1;

FIG. 5 is a perspective view of an alternative geometry for an ablating element;

FIG. 6 is a perspective view of a further embodiment of an ablation catheter system in accordance with the present invention;

FIG. 7 is a perspective view of another embodiment of an ablation catheter in accordance with the present invention;

FIG. 7A is a pictorial representation of an alternative embodiment of an ablation catheter in accordance with the present invention;

5 FIG. 8A is a pictorial representation of a further embodiment of an ablation catheter in accordance with the present invention shown in a first position;

FIG. 8B is a pictorial representation of the catheter of FIG. 8A shown in a second position;

10 FIG. 8C is a pictorial representation of the catheter system of FIG. 8A shown in a a third position; and

FIG. 9 is a perspective view of another embodiment of an ablation catheter system in accordance with the present invention.

DETAILED DESCRIPTION OF THE INVENTION

15 FIGS. 1-3 show an ablation catheter system 100 in accordance with the present invention having an ablation element 102 that is deployable from a flexible elongate catheter or sheath 104. The catheter sheath 104 should be semi-rigid and flexible so as to be readily steerable to a desired location in a patient's body, such as proximate the os
of a pulmonary vein. Such catheter delivery systems are well known to those of
20 ordinary skill in the art. In general, the deployed coil-like ablation element 102 has a shape that includes one or more revolutions substantially oriented in a transverse plane 106 (FIG. 4) that is orthogonal to a longitudinal axis 108 of the sheath 104. This geometry facilitates treating tissue about a circumference of a vessel, such as a
pulmonary vein. The circumferential region of ablated tissue electrically isolates tissue
25 on opposite sides of the ablated tissue. Thus, the atria, for example, can be electrically isolated from any arrhythmia-inducing foci within the pulmonary vein.

In one embodiment, the catheter system 100 includes a tubular inner member 110 for housing the ablation member 102 in the non-deployed position. In general, it is preferred that the inner member 102 be formed from an insulative material to prevent

unintended contact with tissue, for example. Exemplary materials for the insulative inner member 110 include Teflon and polyethylene.

The elongate ablation element 102 can have a variety of geometries that are effective to form a generally annular lesion about a circumference of a vessel wall. Exemplary geometries include annular shapes having one or more revolutions, crenulated, corrugated, and combinations thereof. It is understood that the term “revolution” should be construed broadly to include configurations of somewhat less than three hundred and sixty degrees. It is further understood that the transverse plane 106 on which the revolutions of the elongate member are located provides a general frame of reference and that the elongate member can vary in distance from the plane as the elongate member forms a revolution.

In the exemplary embodiment of FIGS. 1-3, which shows the ablation member 102 in the deployed state, the ablation member 102 has a coil-like appearance that forms approximately one revolution generally oriented in the transverse plane 106 that is substantially orthogonal to a longitudinal axis 108 of the sheath. This configuration is well-suited for contacting a vessel inner wall about its circumference or for contacting the posterior wall of the left atrium to circumscribe the os of a pulmonary vein. The resultant circumferential lesion on the atrial or vessel wall can be effective to isolate electrical impulses from the offending foci from passing to healthy tissue on the opposite side of the lesion.

FIG. 5 shows the catheter system 100' including an ablation member 102' having an alternative, crenulated geometry. That is, the ablation member 102' undulates so as to intersect the transverse plane 106' at defined intervals along a revolution. This configuration may inhibit or limit stenosis of the treated vessel proximate the circumferential lesion. The ablation member 102' can be partly surrounded by an insulative coating 112.

In one embodiment, the ablation member 102 is formed from a conductive elastic or superelastic shape memory material for ablating tissue with RF energy. Exemplary shape memory materials include nickel-titanium alloys, such as Nitinol, and copper based alloys. It is understood that shape memory materials, in general, can be

plastically deformed from a first shape at a relatively low temperature. Upon heating the material to some higher temperature, such as by resistive heating, the material will tend to return to the first shape. Such materials can have so-called one-way and two-way shape memories.

5 In further embodiments (not shown), the ablation member can be at least partly surrounded by an insulative coating. The insulative coating can be disposed on the ablation member so as to form a plurality of discrete electrodes for ablating tissue at selected locations along the vessel circumference.

10 The ablation element can be deployed from the sheath using a variety of mechanisms that are compatible with steerable catheter systems. Exemplary mechanisms include predetermined shapes for the elongate member, manual deployment mechanisms, and guide-wire based mechanisms.

15 FIG. 6 shows an ablation catheter system 200 having an ablation member 202 with a distal end 204 secured to a bulbous end 206 of a support member 208. The support member 208 is disposed within the sheath 210 and connected to an actuator (not shown) at a proximal end of the catheter. To deploy the ablation member 202, the support member 208 is longitudinally displaced with respect to the sheath such that the bulbous end 206 protrudes from the end 212 of the catheter. Upon exiting the sheath 210, the ablation member 202 assumes a predetermined shape that includes about one
20 revolution in a transverse plane 214 orthogonal to the sheath longitudinal axis 216. The ablation member 202 can extend from a retractable support wire 218.

 In one embodiment, the bulbous end 206 of the support member is radiopaque to facilitate determining the ablation member position on an external viewing system, such as an X-ray system.

25 Alternatively, the ablation member 202 can be wound on the support member 208 in the non-deployed state. The support member 208 can be rotated in a predetermined direction such that the ablation member 202 is unwound or released from the support member. The support member 208 can be rotated until the ablation member extends from the support member a desired distance. After ablation, the

ablation member 202 can be retracted to the non-deployed state by rotating the support member in the opposite direction.

FIG. 7 shows an ablation catheter system 300 including a guide wire 302 for manipulating a catheter 304 within the patient's body. It is understood that the guide wire 302 can be utilized in conjunction with mapping systems (which may be separate from or integral with the catheter system 300) to locate arrhythmic foci. The catheter 304 includes a hatch 306 from which an ablation member 308 can be deployed. Upon actuating the hatch 306 to the open position, the ablation member 308 discharges from the resultant opening 310 and assumes a predetermined configuration. It is understood that the predetermined annular shape will be effective to contact vessel walls having a circumference less than or equal to a predetermined value, which by way of example, may be in the range of about 0.4 centimeters to about 4.0 centimeters.

FIG. 7A shows an alternative embodiment of a catheter system 350 including an ablation member 352 having an exposed proximal portion 354 for ablating tissue and an insulated distal portion 356 for centering the catheter within a pulmonary vein 358. The catheter system 350 is well suited for creating a circumferential lesion on the posterior left atrial wall 360 around the pulmonary vein os 362.

FIGS. 8A-C show a manually expandable ablation member 402 that forms a part of a cardiac ablation catheter system 400 in accordance with the present invention. The system 400 includes a guide-wire based catheter 404 with an ablation member 406 that is manually deployable from the catheter. In one embodiment, the ablation member 406 is coupled to a semi-rigid support member 408 (FIG. 8C) that can be rotated and/or longitudinally displaced so as to deploy the ablation member 4026. The size of the loop formed by the ablation member 406 can be selected by controlling the amount of rotation/displacement of the support member 408. Alternatively, the leading end of the ablation element can be affixed to the guide wire. In one embodiment, the ablating element can be manipulated by rotating the guide wire.

FIG. 9 shows a further embodiment of a guide-wire based ablation catheter system 500 having a manually deployable ablation member 502. This system is similar to the system 200 shown in FIG 6 with the addition of a guide wire 504 that can

provide additional stability during ablation. The catheter 506 is mounted on the guide wire 504 to facilitate advancement of the catheter into the pulmonary vein.

5 One skilled in the art will appreciate further features and advantages of the invention based on the above-described embodiments. Accordingly, the invention is not to be limited by what has been particularly shown and described, except as indicated by the appended claims. All publications and references cited herein are expressly incorporated herein by reference in their entirety.

What is claimed is:

10

1. A cardiac catheter system, comprising:
an elongate, flexible sheath having an internal lumen, a distal end and a longitudinal axis;
an ablating element disposed within the sheath and selectively deployable therefrom so as to project from the sheath in a substantially coil-like shape having at least one revolution, wherein the ablating element, in a deployed condition, is oriented in a plane that is substantially orthogonal to the longitudinal axis of the sheath; and
at least one exposed, conductive region disposed on at least a portion of the ablating element.
2. The system of claim 1, wherein the ablating element is self-expanding and assumes a predetermined shape upon deployment from the sheath.
3. The system of claim 2, wherein the ablating element is made from a shape-memory material.
4. The system of claim 3 wherein the shape-memory material is selected from the group consisting of nickel-titanium alloys and copper-based alloys.
5. The system of claim 3 wherein the shape-memory material is superelastic.
6. The system of claim 3, wherein the shape-memory material has a two-way shape memory.
7. The system of claim 1 wherein the ablating element further comprises a terminal which is connectable to an energy source selected from the group consisting of radio frequency energy, laser energy, microwave energy, ultrasonic energy, and cryogenic energy.

8. The system of claim 1, further comprising a guide wire disposed within and selectively deployable from the sheath.

5 9. The system of claim 8, wherein a leading end of the ablating element is secured to the guide wire.

10. The system of claim 9, wherein the ablating element is manually and selectively expandable from the sheath.

10 11. The system of claim 1 wherein the coil-like shape has a radius which expands as the ablating element advances from the sheath.

12. The system of claim 9 wherein the ablating element is expandable from the sheath by rotating the guide wire along the longitudinal axis of the sheath.

15 13. The system of claim 9, wherein the leading end of the ablating element is surrounded by an insulating material.

14. The system of claim 9, wherein a lagging end of the ablating element supports
20 the coil-like shape of the ablating element.

15. The system of claim 1, further comprising a non-conductive, insulating element disposed within the sheath and selectively deployable therefrom, wherein the ablating element is deployable from within the non-conducting, insulating element.

25 16. The system of claim 15 wherein the ablating element is retractable into the non-conductive, insulating element.

30 17. The system of claim 1, wherein the at least one exposed, conductive region further comprises a plurality of discrete electrodes.

18. The system of claim 1, wherein the coil-like shape of the ablating member has a crenulated circumferential region.

5 19. A cardiac catheter system, comprising
an elongate, flexible sheath having dimensions suitable for intravascular passage
and a longitudinal axis;

a guide wire disposed within the sheath and selectively deployable from a distal
end of the sheath;

10 an ablating element disposed within and selectively deployable from the distal
end of the sheath in concert with the guide wire, the ablating element having a leading
end secured to the guide wire and a trailing portion disposed within the sheath; and

15 an ablating element deployment mechanism that is effective to advance at least a
portion of the trailing portion of the ablating element out of the distal end of the sheath
by a predetermined distance to cause the ablating element to assume a coil-like shape.

20. A method for ablating a selected region of body tissue, comprising the steps of:

(a) inserting a catheter into a body, the catheter comprising:

20 an elongate, flexible sheath having an internal lumen, an open distal end and a
longitudinal axis;

an ablating element disposed within the sheath and selectively deployable
therefrom so as to project from the sheath in a substantially coil-like shape having at
least one revolution, wherein the ablating element, in a deployed condition, is oriented
in a plane that is substantially orthogonal to the longitudinal axis of the sheath; and

25 at least one exposed, conductive region disposed on at least a portion of the
ablating element;

(b) advancing the ablating element distally out of the sheath to allow the
ablating element to form a substantially coil-like shape having at least one revolution;

30 (c) contacting the conductive region of the ablating element with a selected
region of body tissue; and

(d) transmitting ablating energy to the ablating element while contacting the selected region of body tissue.

5 21. The method of claim 20, wherein the selected region of body tissue is located on a posterior wall of the left atrium proximate the os of a pulmonary vein.

22. The method of claim 20, wherein the selected region of body tissue is located on an inner wall of a bodily lumen.

10

1/4

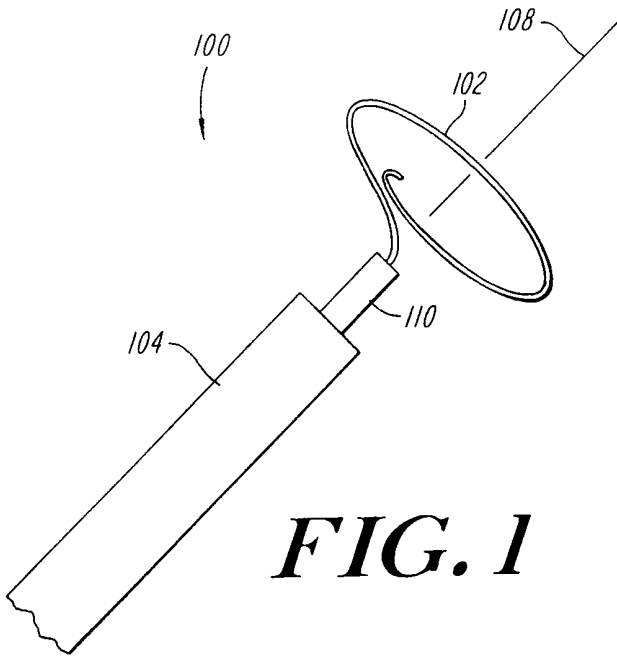

FIG. 1

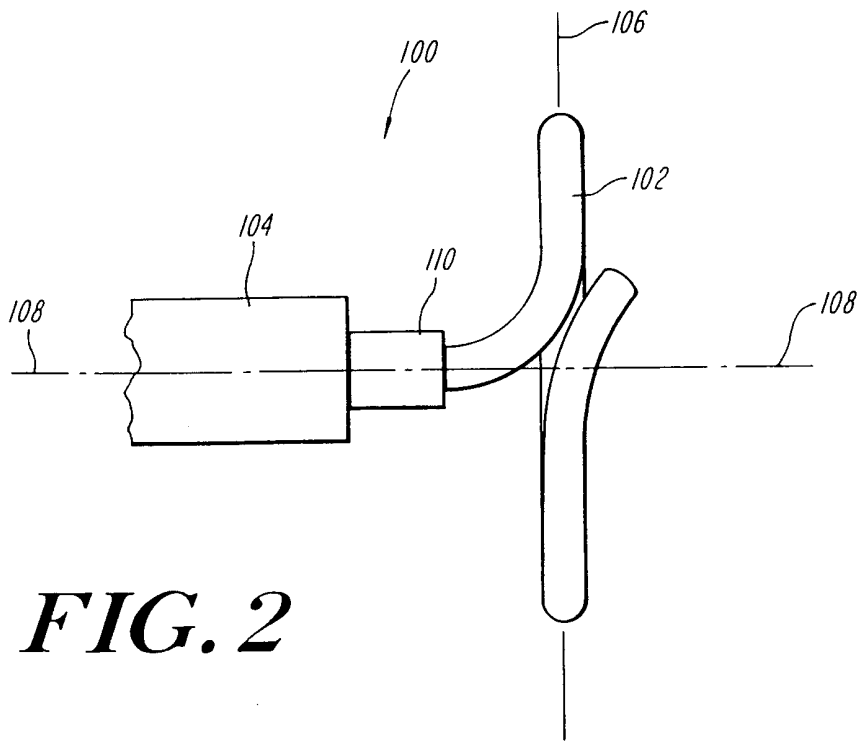

FIG. 2

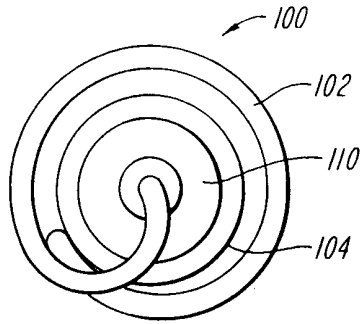

FIG. 3

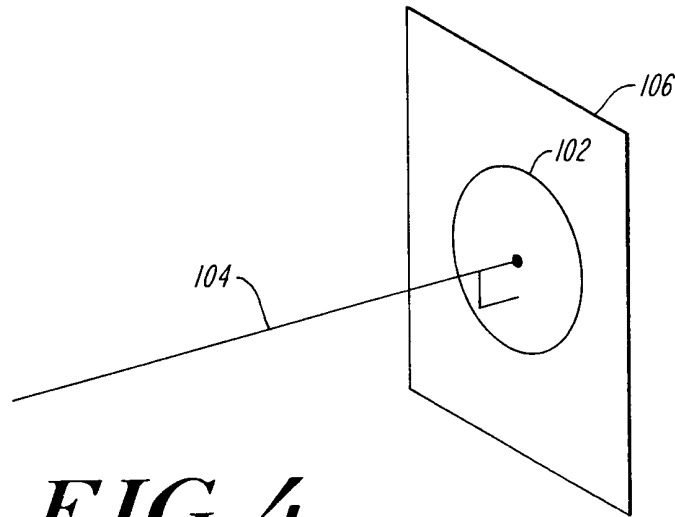

FIG. 4

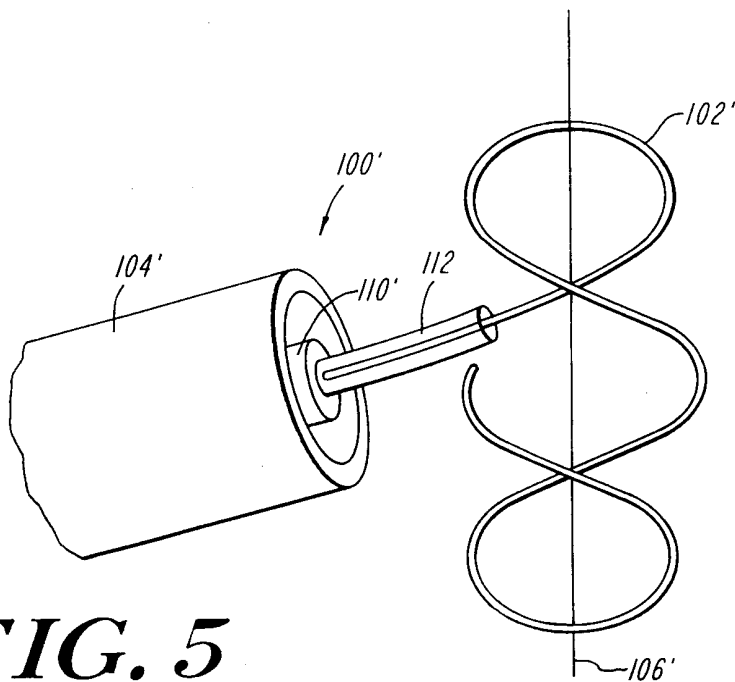

FIG. 5

3 / 4

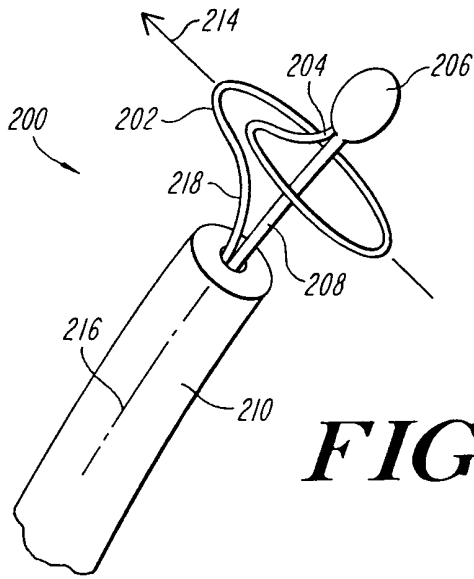

FIG. 6

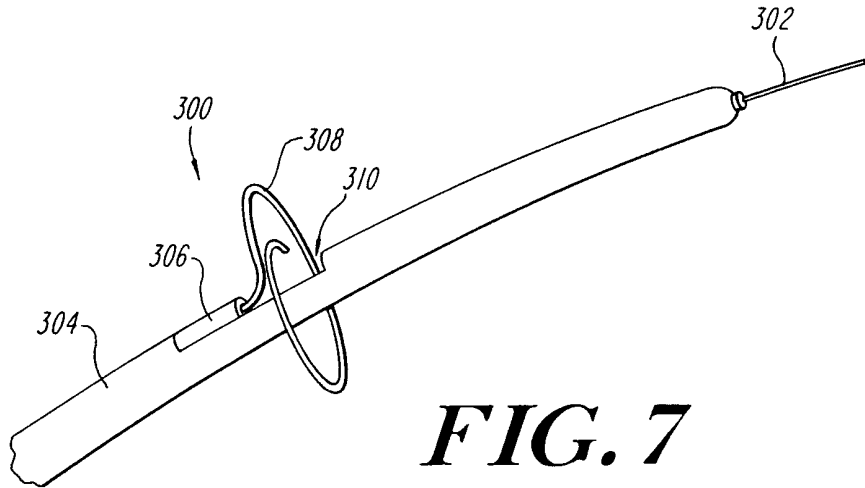

FIG. 7

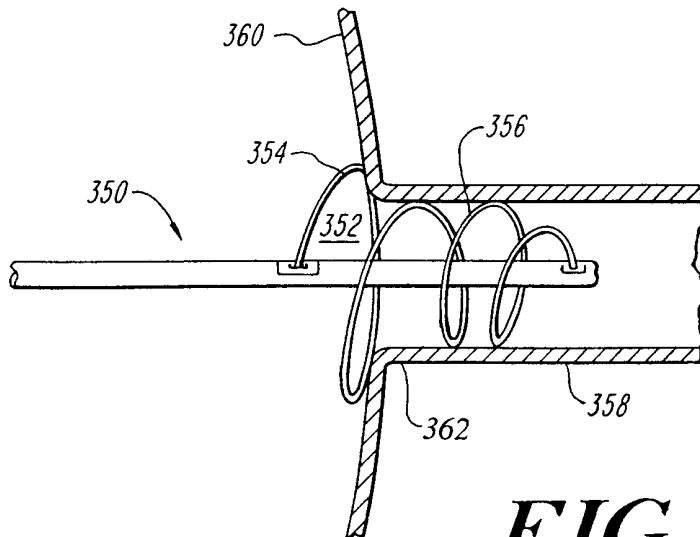

FIG. 7A

4 / 4

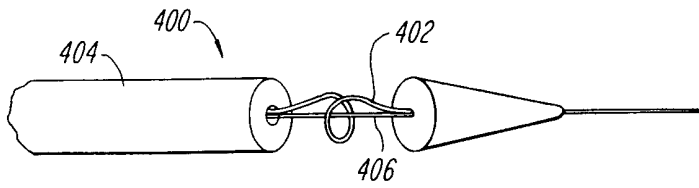

FIG. 8A

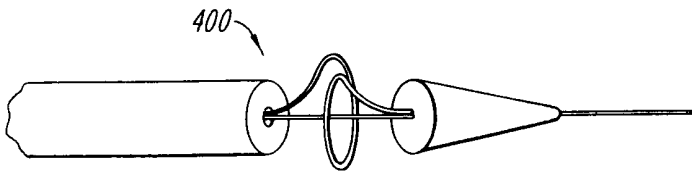

FIG. 8B

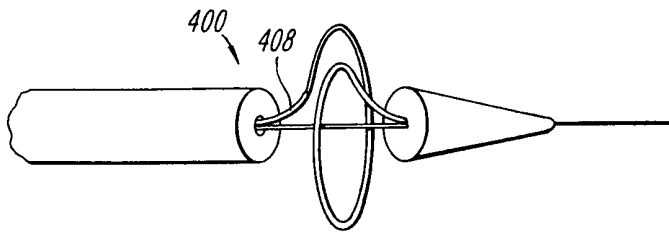

FIG. 8C

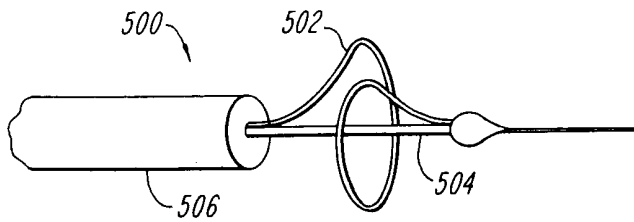

FIG. 9

INTERNATIONAL SEARCH REPORT

International application No.
PCT/US00/24836

A. CLASSIFICATION OF SUBJECT MATTER		
IPC(7) : A61B 18/18 US CL : 606/002 According to International Patent Classification (IPC) or to both national classification and IPC		
B. FIELDS SEARCHED		
Minimum documentation searched (classification system followed by classification symbols) U.S. : 606/002		
Documentation searched other than minimum documentation to the extent that such documents are included in the fields searched		
Electronic data base consulted during the international search (name of data base and, where practicable, search terms used)		
C. DOCUMENTS CONSIDERED TO BE RELEVANT		
Category*	Citation of document, with indication, where appropriate, of the relevant passages	Relevant to claim No.
Y	US,5,836,940 A (Gregory) 17 November 1998, see entire document.	1-22
Y	US, 5,507,743 A (Edwards et al.) 16 April 1996, see entire document.	1,20
Y	US, 5,476,495 A (Kordis et al.) 19 December 1995, see entire document.	1-18
Y	US, 5,738,683 A (Osypka) 14 April 1998, see entire document.	19-22
<input type="checkbox"/> Further documents are listed in the continuation of Box C. <input type="checkbox"/> See patent family annex.		
* *A* *E* *L* *O* *P*	Special categories of cited documents: document defining the general state of the art which is not considered to be of particular relevance earlier document published on or after the international filing date document which may throw doubts on priority claim(s) or which is cited to establish the publication date of another citation or other special reason (as specified) document referring to an oral disclosure, use, exhibition or other means document published prior to the international filing date but later than the priority date claimed	*T* *X* *Y* *&*
		later document published after the international filing date or priority date and not in conflict with the application but cited to understand the principle or theory underlying the invention document of particular relevance; the claimed invention cannot be considered novel or cannot be considered to involve an inventive step when the document is taken alone document of particular relevance; the claimed invention cannot be considered to involve an inventive step when the document is combined with one or more other such documents, such combination being obvious to a person skilled in the art document member of the same patent family
Date of the actual completion of the international search 16 NOVEMBER 2000		Date of mailing of the international search report 28 DEC 2000
Name and mailing address of the ISA/US Commissioner of Patents and Trademarks Box PCT Washington, D.C. 20231 Facsimile No. (703) 305-3230		Authorized officer AHMED M. FARAH Telephone No. (703) 308- 3549