

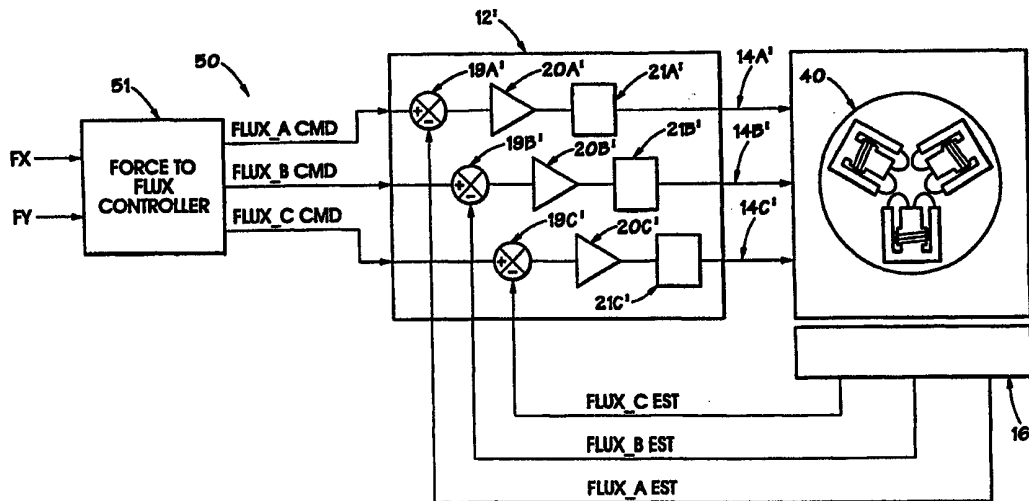

INTERNATIONAL APPLICATION PUBLISHED UNDER THE PATENT COOPERATION TREATY (PCT)

<p>(51) International Patent Classification ⁶ : B23K 20/12, H02P 7/00, B06B 1/02</p>	<p>A1</p>	<p>(11) International Publication Number: WO 99/62666</p> <p>(43) International Publication Date: 9 December 1999 (09.12.99)</p>
<p>(21) International Application Number: PCT/IB99/01142</p> <p>(22) International Filing Date: 2 June 1999 (02.06.99)</p> <p>(30) Priority Data: 09/088,922 2 June 1998 (02.06.98) US</p> <p>(71) Applicant: SWITCHED RELUCTANCE DRIVES LIMITED [GB/GB]; East Park House, Otley Road, Harrogate, North Yorkshire HG3 1PR (GB).</p> <p>(72) Inventors: LOVETT, Donald, C.; 15 L'Hermitage Drive, Shelton, CT 06484 (US). MARCINKIEWICZ, Joseph, G.; 136 Roehampton Lane, St. Charles, MO 63304 (US).</p> <p>(74) Agent: HALE, Peter; Kilburn & Strode, 20 Red Lion Street, London WC1R 4PJ (GB).</p>		<p>(81) Designated States: AE, AL, AM, AT, AU, AZ, BA, BB, BG, BR, BY, CA, CH, CN, CU, CZ, DE, DK, EE, ES, FI, GB, GD, GE, GH, GM, HR, HU, ID, IL, IN, IS, JP, KE, KG, KP, KR, KZ, LC, LK, LR, LS, LT, LU, LV, MD, MG, MK, MN, MW, MX, NO, NZ, PL, PT, RO, RU, SD, SE, SG, SI, SK, SL, TJ, TM, TR, TT, UA, UG, UZ, VN, YU, ZA, ZW, ARIPO patent (GH, GM, KE, LS, MW, SD, SL, SZ, UG, ZW), Eurasian patent (AM, AZ, BY, KG, KZ, MD, RU, TJ, TM), European patent (AT, BE, CH, CY, DE, DK, ES, FI, FR, GB, GR, IE, IT, LU, MC, NL, PT, SE), OAPI patent (BF, BJ, CF, CG, CI, CM, GA, GN, GW, ML, MR, NE, SN, TD, TG).</p> <p>Published <i>With international search report.</i> <i>Before the expiration of the time limit for amending the claims and to be republished in the event of the receipt of amendments.</i></p>

(54) Title: TRAJECTORY CONTROLLER



(57) Abstract

A system for controlling the movement of a movable member with respect to a stationary member, such as is found in a vibration welding apparatus. The system may include a force controller that converts desired force command signals into desired flux command signals and a flux controller that controls the flux in a magnetic core of the stationary assembly to effect the desired movement of the movable member. The stationary assembly may include a plurality of magnetically uncoupled E-cores of paramagnetic material.

FOR THE PURPOSES OF INFORMATION ONLY

Codes used to identify States party to the PCT on the front pages of pamphlets publishing international applications under the PCT.

AL	Albania	ES	Spain	LS	Lesotho	SI	Slovenia
AM	Armenia	FI	Finland	LT	Lithuania	SK	Slovakia
AT	Austria	FR	France	LU	Luxembourg	SN	Senegal
AU	Australia	GA	Gabon	LV	Latvia	SZ	Swaziland
AZ	Azerbaijan	GB	United Kingdom	MC	Monaco	TD	Chad
BA	Bosnia and Herzegovina	GE	Georgia	MD	Republic of Moldova	TG	Togo
BB	Barbados	GH	Ghana	MG	Madagascar	TJ	Tajikistan
BE	Belgium	GN	Guinea	MK	The former Yugoslav Republic of Macedonia	TM	Turkmenistan
BF	Burkina Faso	GR	Greece	ML	Mali	TR	Turkey
BG	Bulgaria	HU	Hungary	MN	Mongolia	TT	Trinidad and Tobago
BJ	Benin	IE	Ireland	MR	Mauritania	UA	Ukraine
BR	Brazil	IL	Israel	MW	Malawi	UG	Uganda
BY	Belarus	IS	Iceland	MX	Mexico	US	United States of America
CA	Canada	IT	Italy	NE	Niger	UZ	Uzbekistan
CF	Central African Republic	JP	Japan	NL	Netherlands	VN	Viet Nam
CG	Congo	KE	Kenya	NO	Norway	YU	Yugoslavia
CH	Switzerland	KG	Kyrgyzstan	NZ	New Zealand	ZW	Zimbabwe
CI	Côte d'Ivoire	KP	Democratic People's Republic of Korea	PL	Poland		
CM	Cameroon	KR	Republic of Korea	PT	Portugal		
CN	China	KZ	Kazakstan	RO	Romania		
CU	Cuba	LC	Saint Lucia	RU	Russian Federation		
CZ	Czech Republic	LI	Liechtenstein	SD	Sudan		
DE	Germany	LK	Sri Lanka	SE	Sweden		
DK	Denmark	LR	Liberia	SG	Singapore		
EE	Estonia						

-5

TRAJECTORY CONTROLLER

The present invention relates to a novel flux control system and, more particularly, to a flux control system for use in motion control applications. Even more particularly, the present invention relates to a novel motion control system for use in friction welders.

In most electromagnetic systems, the transfer of energy from one component of the system to another is critical to proper operation of the system. In many electromagnetic systems, this transfer of energy is accomplished by appropriately energizing one component of the system to establish a magnetic flux that interacts with another component of the system to transfer energy from the energized component to the other component. Despite the fact that the energy transfer is accomplished by the flux, in known electromagnetic systems, the flux of the system is not directly controlled. Instead, the current and/or voltage applied to the energized member is controlled and, based on assumed relationships between current, voltage and flux, it is assumed that the control of the current and/or voltage based on the assumed relationships will produce the appropriate flux. This control of current and/or voltage is typically implemented because, to date, the prior art has not provided an efficient, low cost, and easily-implemented system for directly controlling flux in an electromagnetic system.

One drawback of current and/or voltage control systems as described above is that the relationships between current, voltage and flux are not easily represented mathematically and vary in a non-linear manner depending on a variety of variables. For example, the particular characteristics of each piece of magnetic material in a system will result in voltage, current and flux relationships that vary from one system to another and, even within a given system, from one section of the system to another. Because of these differing voltage, current and flux relationships, it is difficult to accurately and properly control the currents and/or voltages to produce the desired flux and, thus, the desired energy transfer. As such, the prior art is limited in its ability to provide an electromagnetic system in which flux is directly controlled.

The lack of an appropriate flux control system in the prior art is particularly noticeable in electromagnetic systems where the force exerted by one component of the

- 5 system on another component of the system is desired to be finally controlled. In such systems, the actual force produced by the system is related to the flux established by the energized component of the system. As described above, however, because the prior art cannot directly and finely control flux, it cannot, therefore, finely control the force produced by such systems.

10 The inability of the prior art to finely control the forces established in an electromagnetic system is particularly acute in applications where the movement of at least one component of the system must be precisely controlled. One example of such an application is in a friction or vibration welder for driving a thermoplastic part to be welded with linear, orbital, rotational, or arbitrary vibratory motion relative to another
15 thermoplastic part with the two parts in forced contact along surfaces thereof to be welded such that the relative movement of the parts relative to one another causes friction to heat the parts along the intersections thereof so that upon cessation of the movement, the parts will cool and will be welded to one another.

Friction welders are especially suitable for use in the welding of thermoplastic
20 parts by means of either linear, spin, or orbital vibratory forces which induce friction heating in the parts. This friction heating at the interface of the surfaces to be welded causes the parts to fuse at their interface surfaces and bond together as they cool. Although the vibratory forces generating the friction heating may be created through mechanical coupling means, it is common to employ an electromagnetic system to
25 generate the controlled motion necessary.

Numerous friction welders driven either electromagnetically or hydraulically are commercially available for operating in a linear vibratory mode. However, the motion of these friction welders is not ideal. Due to the linear or side-to-side motion of the welding component, the frictional forces at the interface of the welding materials are translational,
30 and drop to a zero velocity each time the welding components reverse direction. When the components are at zero velocity, no heat is produced, as friction welding is a resistance process, producing heat proportional to the product of the resistance forces and the mean-squared relative velocity of the components at the interface.

Furthermore, many linear motion welding systems employ electromagnetic
35 systems or drivers using the known "Scott Tee" magnetic circuit to convert three-phase

-5 electrical power into one-phase mechanical motion. In such systems, because of the
electromagnetically-linked nature of the driver component of the system, it is difficult to
precisely control movement of the movable member in all directions and to limit zero
velocity intervals for the movable member. Accordingly alternative motions and
controllers for frictional welding components have been developed which seek to reduce
10 or minimize the zero velocity components and simplify the control circuits.

Spin welding is one such alternative in which the welding components are spun
about an axis, and rotational forces, not linear motion, produce the frictional heating at
the interface. However, the rotational forces are proportional to the radial distance from
the center of rotation, and accordingly neither the velocity of the components nor the
15 resulting heating is radially uniform. Furthermore, spin welding is generally restricted to
applications where the parts to be welded have circular geometry.

A second alternative is to electromagnetically produce an orbital motion of the
welding components. During orbital motion, the velocity of the components remains
constant as the parts are rubbed, thereby generating the same amount of frictional heating
20 as is generated by linear motion, but with less required force and less relative
displacement of the welding components.

Despite the heating advantages of orbital welding, there are parts which are not
amenable to welding with orbital motion, but are amenable to welding by either linear or
spin motion. Accordingly, friction welders which are electromagnetically driven and
25 capable of producing either linear motion or orbital motion have been developed. One
such friction welder is disclosed in *Snyder*, U.S. Patent No. 5,378,951. The
electromagnetic drive system of these friction welders is in several ways similar to that
for an electromagnetic motor.

In such systems, three coupled magnetic coils are positioned equidistantly around
30 the circumference of the welder, in a plane parallel to the plane of motion. The coupled
magnetic coils are electrically connected in either a delta or "Y" connection to essentially
form an orbital motor stator component. A triangular armature or rotor component
separately formed as a single body of magnetic material is positioned centrally relative to
the stator component, such that each face of the triangular armature is adjacent to a
35 magnetic coil. The armature is maintained in the horizontal orbital plane by a flexural

5 spring support system connected to a massive stationary frame. Orbital motion of the
armature results from the application of a controlled three-phase AC current to the
coupled magnetic coils, producing force on the armature proportional to the flux
generated. This armature motion can be resolved into displacement, velocity, and
acceleration vectors proportional in amplitude to the sine and cosine of twice the AC
10 power line frequency. Linear motion of the armature is produce by the addition of a
second orbital motor or by splitting each coupled magnetic coil of a single orbital motor
into two sections and selectively applying current to various sections in either parallel or
series combinations.

Several disadvantages arise from producing orbital motion using coupled
15 magnetic coils. First, employing coupled magnetic coils reduces the system's overall
performance, as force generated in one direction always generates counteracting force
elements in the opposite direction due to the coupling of the flux paths in the magnetic
circuit. Second, the system is incapable of producing motion which is neither orbital nor
linear, i.e. pure arbitrary motion. It is desirable to produce arbitrary motion of the
20 welding components when the system needs to compensate for uneven mass distribution
of the armature, or when random orbits are desired.

Finally, the control systems for producing the orbital or linear motion of the
armature become complex. When coupled magnetic coils are used in an orbital motor,
the magnetic flux within the system is constrained to sum to zero. If in addition, the AC
25 phase currents are also constrained to sum to zero, there are not enough degrees of
freedom in the magnetic system to generate the arbitrary forces for producing arbitrary
motion. If, however, the phase currents are not constrained to sum to zero, enough
degrees of freedom exist in the magnetic system to produce the arbitrary forces, but a
continuous flux operation is required to generate these arbitrary forces.

30 The flux across each air gap between the magnetic coils and the adjacent faces of
the armature in such systems is a function of all three phase currents and the non-linear
magnetics. At no time is there an unused or unenergized magnetic coil. This limits the
ability to use any form of fine flux control in such systems.

It is an object of the present invention to overcome these and other limitations of
35 the prior art.

-5 Among the several objects and features of the present invention may be noted the provision of an electromagnetic drive circuit and controller having uncoupled magnetic coils located on a stationary stator means, an armature located central to the stator means and capable of movement within the plane of the stator, and a means for independently controlling the application of alternating current to each of the uncoupled magnetic coils
10 so as to generate an electromotive force acting on the armature, the combination of such forces capable of inducing linear, orbital, rotational, or arbitrary movement of the armature;

 The provision of such an electromagnetic drive circuit and controller which contains simple flux observation and control circuits;

15 The provision of such an electromagnetic drive circuit and controller which excites the magnetic coils with unipolar flux waveforms which are zero for a finite amount of time (discontinuous flux);

 The provision of such an electromagnetic drive circuit and controller which does not require additional sensors for determining armature position;

20 The provision of such an electromagnetic drive circuit and controller which uses flux measurements taken from unenergized magnetic coils to determine the armature air gap and the armature plane position;

 The provision of such an electromagnetic drive circuit and controller which provides an improved force per unit flux generation, reducing the total root mean square
25 flux in the magnetic system and allowing the application of reduced drive currents;

 The provision of such an electromagnetic drive circuit and controller which employs simplified force to flux transformations;

 The provision of such an electromagnetic drive circuit and controller which employs a simplified flux sensor capable of being reset during known zero flux
30 conditions;

 The provision of such an electromagnetic drive circuit and controller which employs accelerometers sensing X and Y acceleration of the armature within the plane of movement.

- 5 The provision of such an electromagnetic drive circuit and controller which can compensate for armature or tool asymmetries and load disturbances, preventing deviation from the desired armature motion; and

 The provision of such an electromagnetic drive circuit and controller which employs a combination of digital and analog components to control the application of
10 AC current to the magnetic coils.

 Accordingly, it is the principal object of the present invention to provide an improved electromagnetically drive circuit and control capable of producing linear, orbital, rotational, and arbitrary armature vibrational motions. Briefly described, the electromagnetically drive circuit and control of the present invention includes a means
15 for driving an armature with either a linear, orbital, rotational, or arbitrary planar motion with respect to a stator. The driving means comprises uncoupled electromagnetic force generating means which produce forces parallel to the plane of motion, interacting with the magnetic armature. The present invention provides simplified motion control
20 systems and sensor means, and is capable of altering the motion of the armature to produce any desired trajectory within the confined plane of motion.

 The foregoing and other objects, features, and advantages of the invention as well as presently preferred embodiments thereof will become more apparent from the reading of the following description in connection with the accompanying drawings.

 Figure 1 illustrates a novel flux control system according to certain aspects of the
25 present invention.

 Figures 2A and 2B illustrate in greater detail one exemplary embodiment of a flux control system as illustrated in Figure 1.

 Figure 2C illustrates an exemplary embodiment of a return to zero error control circuit.

30 Figure 3A generally illustrates an exemplary embodiment of an open loop flux observer that may be used in the control system of Figure 1.

 Figure 3B generally illustrates a circuit utilizing a low pass filter providing a signal corresponding to flux in an electromagnetic system.

 Figure 4 generally illustrates an electromagnetic actuator that may be used with a
35 novel flux control system of Figure 1.

-5 Figure 5 generally illustrates one example of a force control system implementing desired force to flux transformation constructed according to certain teachings of the present invention.

 Figures 6A-6D generally illustrate through the use of pseudo-code blocks, an exemplary form of a force to flux transformation that may be implemented through the
10 use of a program microcontroller or microprocessor.

 Figure 7A generally illustrates a representation of the various phase coils of the actuator of Figure 4 that should be energized to produce force for desired force factor in terms of X and Y.

 Figure 7B generally illustrates a group of function blocks that, when
15 implemented, generate the appropriate flux commands to implement the flux to force transformation reflected by Figure 7A.

 Figures 8A-8C generally illustrate function blocks for a force to flux controller that may be used to produce linear movement of a movable member.

 Figure 9 provides a high-level block diagram of an exemplary position control
20 system constructed according to certain teachings of the present invention. It may be used to construct a vibration welding apparatus.

 Figure 10a illustrates generally function blocks that may be used to implement a position controller for use in the apparatus of Figure 9.

 Figure 10B illustrates function blocks similar to those of Figure 10A that are
25 adjusted to reflect a controller operating on a sampling basis.

 Figure 11A generally illustrates an exemplary set of function blocks that may be used to implement a position command generator in accordance with certain teachings of the present invention.

 Figure 11B illustrates a position command generator similar to that of Figure 10A
30 that operates on a sampling basis to produce position command signals in response to sampled input signals.

 Figures 12A-12D generally illustrate the operation of a position controller of the type illustrated in Figure 9 for various modes of operation.

 Figure 13 generally illustrates one form of a QD control system constructed
35 according to certain teachings of the present invention.

-5 Figures 14A-14D generally illustrate function blocks that may be used to implement the exemplary QD controller of Figure 13.

 Corresponding reference characters indicate corresponding parts throughout the several views of the drawings.

 Turning to the drawings and, in particular, to Figure 1, a novel flux control
10 system 10 constructed according to certain aspects of the present invention is shown. In general, the novel system 10 includes a flux controller 12 that receives at an input flux command 13 and provides as an output a phase coil energization signal 14. The phase coil energization signal 14 is provided, through appropriate means, to an electro-magnetic system 15. A flux observer 16 provides a feedback signal to flux controller 12
15 that corresponds to the flux in the electro-magnetic system 15. In general, the flux controller 12 provides phase coil energization signals 14 that energize the electro-magnetic system 15 such that the flux in the electro-magnetic system 15 follows the flux command 13.

 The electro-magnetic system 15 may be any electro-magnetic system that
20 includes at least one phase coil and a core, where the phase coil can be energized through the application of electric power (e.g., through the application of controlled voltage and/or current) to establish a flux in the core. For example, the electro-magnetic system 15 may be as simple as an iron-core inductor with a phase coil wrapped about a core or a transformer having primary and secondary windings each wound about a core.

25 The flux control system 10 of the present invention is believed to have particular application to electro-magnetic systems 15 that constitute electro-magnetic actuators where energization of the system 15 produces movement of a movable member. For example, the flux control system of Figure 1 is believed to have particular applicability to electro-magnetic systems 15 that include a main core (or a plurality of magnetically
30 uncoupled cores) about which one or more phase coils are wound. In such embodiments, a movable member is typically provided that interacts with the core when the core is energized such that energization of the core causes movement of the movable member. The movable member may be a piece of paramagnetic material (e.g., steel) or a stack of laminations of such materials that interacts with the energized core in a manner
35 similar to the interaction between the rotor and stator of a reluctance machine.

5 Alternately, the movable member may include one or more permanent magnets (or electro magnets or even induction coils) that interact with the energized core in a manner similar to the interaction between the rotor and stator of a permanent magnetic machine. While the following discussion is in the context of one or more particular electro-magnetic systems 15, it will be understood by those of ordinary skill in the art that the
10 flux control system 10 described may be used with a number of electro-magnetic systems 15 and that the discussion herein is for purposes of illustrating and explaining the present invention and not for limiting the scope of the claims presented herein.

In Figure 1, the electro-magnetic system 15 is illustrated as having only a single phase coil. In applications where the electro-magnetic system 15 includes a plurality of
15 phase coils, the energization signal 14 may take the form of an energization vector that includes separate energization signals for each of the individual phase coils. In such applications, the flux command 13 may take the form of a flux command vector that includes separate flux command signals for each of the various phase coils. In such applications, the flux associated with each of the phase coils may be independently
20 controlled. For purposes of clarity, the following discussion initially focuses on the structure and operation of the flux controller 12 in the context of a system having an electro-magnetic system 15 including only a single phase coil. Those of ordinary skill in the art will appreciate that a multi-phase flux controller 12 can be constructed by simply duplicating the single-phase flux control system described herein.

25 Figures 2A and 2B illustrate in greater detail one exemplary embodiment of flux control system 10. Figure 2B illustrates an electric drive circuit for energizing the electro-magnetic system 15 and Figure 2A illustrates a control circuit that provides the control signals for the drive of Figure 2B. The drive of Figure 2B will be discussed first.

In the illustrated embodiment, the electro-magnetic system 15 is illustrated as a
30 single phase coil wound about a core. The phase coil defines two ends. The two ends of the phase coil are coupled across a high voltage DC bus (V_{HDC}) by a switching bridge comprising upper switching device 17, lower switching device 18, lower flyback diode 19 and upper flyback diode 20. Switching devices 17 and 18 may be any suitable controllable switching device such as a power MOSFET, BJT, BIFET, IGBT, MCT,
35 standard FET or other suitable switching device that can be controlled through

-5 application of a control signal. In the illustrated embodiment, upper switching device 17 is controlled by control signal SU and lower switching device 18 is controlled by control signal SL. Flyback diodes 19 and 20 may be any device exhibiting diode-like (e.g., one-way) current characteristics.

In general, the switching signals SU and SL may be actuated to produce three
10 switching conditions: (i) a first condition where both the upper and lower switching devices 17 and 18 are rendered conductive; (ii) a second condition where only one of the switching devices is rendered conductive; and (iii) a third condition where neither switching device is rendered conductive. When the switching signals SU and SL are in the first condition, such that both upper and lower switching devices 17 and 18 are
15 rendered conductive, the phase coil 18 will be coupled across the V_{HDC} bus, thus causing electric current to flow from the positive rail of the V_{HDC} bus (e.g., $+V_{HDC}$) through the phase coil of electro-magnetic system 15 to the ground of the V_{HDC} bus. This current flow will cause energy to be transferred from the V_{HDC} bus to the electro-magnetic system 15, thus resulting in an increase in the flux of the system 15.

20 When the switching signals SU and SL are in the second condition, such that only one of the switching devices 17 or 18 is rendered conductive and the other is rendered non-conductive, the voltage applied across the phase coil of system 15 will be approximately zero. Under this second switching condition, any current in the phase coil will "freewheel" through the conductive switching device and one of the flyback diodes.
25 For example, if there is current in the phase coil 15 and the signals SU and SL are such that the upper switching device 17 is rendered conductive and lower switching device 18 is non-conductive, the current in the phase coil will "freewheel" from the positive rail of the V_{HDC} bus, through the phase coil, and back to the positive rail of the V_{HDC} bus through upper flyback diode 20. The voltage applied across the phase coil in such
30 circumstances will be the voltage drop across flyback diode 20 plus the voltage across device 17, or approximately zero voltage. A similar substantially zero-voltage condition will be obtained when lower switching device 18 is rendered conductive and upper switching device 17 is non-conductive. Under such circumstances, the current will freewheel through lower switching device 18 and lower flyback diode 19. When the
35 current in the phase coil is in a freewheel condition, the flux established by the phase coil

5 will remain substantially constant or decrease slightly. As such, the energy in the electro-magnetic machine, and thus the flux, will remain substantially constant or decrease slightly.

When the switching signals SU and SL are in the third condition, such that both the upper and lower switching devices 17 and 18 are open, any current in the phase coil upon the initiation of this switching condition will continue to flow because the phase
10 coil is an inductive element and the current cannot instantaneously drop to zero. Because the upper and lower switching devices 17 and 18 are non-conductive, however, the path for this current flow will be from the ground rail of the V_{HDC} bus, through lower flyback diode 19, through the phase coil of the system 15, and to the positive rail of the V_{HDC} bus
15 through the upper flyback diode 20. Thus, in this third condition, the phase coil of system 15 will be coupled in a negative fashion across the V_{HDC} bus such that the negative of the V_{HDC} bus is applied across the phase winding. This application of the negative of the V_{HDC} bus to the phase winding will tend to rapidly drive any flux and hence current in the phase winding down to zero. Thus, when the SU and SL signals are
20 in the third condition, energy stored in the electro-magnetic system 15 will be dissipated or returned to the V_{HDC} bus and the energy in the system, and thus the flux, will drop.

Those of ordinary skill in the art will appreciate that the particular switching scheme illustrated in Figures 2A and 2B is but one such scheme that may be used to control the energization of a phase coil. Other switching schemes, for example,
25 switching schemes utilizing a full H-bridge with four switching devices, may be used. In general, any switching arrangement may be used to implement the systems described herein that allow for the energization of the phase coil to be controlled such that the flux in the system 15 is increased, remains substantially constant, or is reduced.

In the embodiment of Figures 2A and 2B, the switching signals SU and SL are
30 provided by flux controller 12. A schematic representation of an exemplary flux controller 12 is provided in Figure 2A.

Referring to Figure 2A, the illustrated flux controller 12 comprises a summing junction 19 that receives at a positive input a flux command signal 13 corresponding to the desired flux level, and at a negative input, a flux feedback signal from flux observer
35 16 that corresponds to the flux in the electro-magnetic system 15. Summing junction 19

5 subtracts the flux feedback signal from the flux command 13 to produce an error signal that varies with the difference between the actual flux and the desired flux. When the flux error signal is positive, the flux command is greater than the flux feedback and it will be necessary to increase the flux in system 15 to bring the flux in line with the flux command. When the error signal is negative, the feedback flux is greater than the flux
10 command, and it will be necessary to decrease the flux in the system 15 to bring the flux in the system in line with the flux command. The error signal from summing junction 19 is first amplified by amplifier 20 and then provided to an energization control circuit 21.

Energization control circuit 21 generates switching signals SU and SL to increase, decrease, or stabilize the flux in the electromagnet system 15 depending on the
15 magnitude of the error signal.

Energization control circuit 21 may take many forms. For example, the controller may utilize a form of conventional pulse width or pulse frequency modulation to control the energization of the phase coil. Alternately, the energization control circuit 21 may take the form of a controller that will close both switching devices 17 and 18 when the
20 error signal is positive; open both switching devices when the error signal is negative; and open one switching device and close the other when the error signal is zero. In accordance with one embodiment of phase controller 21, the switching signals SU and SL are controlled such that the error signal is driven to zero and allowed to freewheel until the error signal falls outside of a controlled hysteresis band. Such a time hysteretic
25 controller is referred to herein as a "return to zero error" or RZE controlled. The described RZE controller is advantageous in that, for applications where the desired flux command is not rapidly changing and the available power is large enough to force tracking relatively quickly, it provides for rapid tracking of the flux command signal such that the "delay" in the flux reference tracking is less than one sampling period of the
30 control system.

A detailed schematic illustrating one embodiment of an RZE control circuit as described herein is illustrated in Figure 2C. In general, the RZE controller 21 of Figure 2C includes an upper comparator 22A and a lower comparator 22B that, together, establish two adjacent, asymmetric, hysteresis bands, centered about zero error. Each of
35 the comparators handles only one polarity of error. The outputs from the two

-5 comparators are provided to inverters 23a and 23b and the outputs of the two inverters correspond to the SU and SL signals.

In general, when the magnitude of the error signals from amplifier 20 is large and positive (indicating that there is a need to increase the flux in the electro-magnetic system) the outputs of both comparators 22a and 22b will be low. Assuming that the
10 upper and lower switching devices 17 and 18 are of the type that are rendered conductive when positive voltage is applied to the control gates of the devices, the low outputs of the comparators 22a and 22b will be inverted by inverters 23a and 23b to produce high level SU and SL signals, thus placing the switching devices into the first switching conduction, such that the flux in the electro-magnetic system 15 will tend to increase.

15 When the magnitude of the error signals from amplifier 20 is large and negative, the outputs of both comparators 22a and 22b will be high. These high signals will be inverted by inverters 23a and 23b, resulting in low voltage SU and SL signals that will cause both the upper and lower switching devices 17 and 18 to be rendered non-conductive, thus driving the current in the electro-magnetic system (and, thus, the flux)
20 down.

When the error signal from amplifier 20 is between large positive and large negative values, the status of switching signals SU and SL will depend on the magnitude of the error signal as it compares to the hysteresis voltages $+V_H$ and $-V_H$. In the illustrated embodiment, the application of the hysteresis voltages $+V_H$ and $-V_H$ is
25 controlled by a trigger signal T such that, when T (24a) is logic high, the hysteresis voltage $+V_H$ is applied to the positive input of the comparator 22a and no hysteresis voltage is applied to lower comparator 22b and that when T (24b) is logic low, the hysteresis voltage $-V_H$ is applied to lower comparator 22b and no hysteresis voltage is applied to upper comparator 22a. As explained below, the trigger signal T changes state
30 to control the application of the hysteresis voltages $+V_H/-V_H$ to the comparators 22a and 22b.

Assuming that an initial conditions exist where the trigger signal is logic high, and the flux in the electro-magnetic system 15 is below the command flux such that the error signal from amplifier 20 is large positive and the outputs of comparators 22a and
35 22b are both low (resulting in logic high SU and SL signals). Under such conditions, the

- 5 flux in the system 15 would begin to increase and, thus, the magnitude of the error signals from 20 would begin to decrease. At some point, the magnitude of the error signal will begin to decrease from a large positive value towards zero. At the point where the error signal reaches and passes zero, the output of the lower comparator 22b (which has no hysteresis feedback) will change state, thus resulting in a transition of the
10 SL signal from high to low. This will cause the switching arrangement to be placed into the second switching condition, such that the current in the electro-magnetic system 15 will freewheel, resulting in a constant or slightly decreasing flux. This change in the state of the SU and SL signals will also cause a change in the state of the trigger signal T, thus resulting in the application of the $-V_H$ feedback voltage to the lower comparator. If
15 the flux decreases to the point where the error signal from amplifier 20 now drops below the hysteresis value, the output of the lower comparator 22b will change states again, resulting in the SL signal changing from low to high and thus again applying power to the electro-magnetic system 15 causing the flux in the system 15 to increase, and chopping will occur at error signals between $-V_H$ and zero.

20 Assuming that a second set of initial condition exists where the trigger signal is logic low, and the flux in the electro-magnetic system 15 is above the command flux such that the error signal from amplifier 20 is a large negative and the outputs of comparators 22a and 22b are both high (resulting in logic low SU and SL signals). Under such conditions, the flux in the system 15 would begin to decrease and, thus, the
25 magnitude of the error signal from amplifier 20 would begin to increase. At some point, the magnitude of the error signal will increase from a large negative value to zero. At the point where the error signal reaches and passes zero, the outputs of both the upper and lower comparators 22a and 22b will have changed state, thus resulting in a transition of both the SU and SL signals from logic low to logic high. This will cause the switching
30 arrangement to be placed into the first switching condition, such that the current in the electro-magnetic system 15 will increase, resulting in an increasing flux. This change in the state of the SU and SL signals will also cause a change in the state of the trigger signal T, thus resulting in the application of the $+V_H$ feedback voltage to the upper comparator 22b. If the flux increases to the point where the error signal from amplifier
35 20 now exceeds the hysteresis value, the output of the upper comparator 22b will change

- 5 states again, resulting in the SU signal changing from logic high to logic low. The SL signal will remain logic high, and thus, the switching arrangement will be placed into the freewheel condition causing the flux in the system 15 to remain constant or slightly decrease, and chopping will occur at error signals between zero and $+V_H$.

Thus, as described above, the hysteretic controller of Figure 2C can control the
10 flux in the electro-mechanical system 15 such that the flux: (i) is increased when the flux is below the desired level by a negative hysteresis amount; (ii) is decreased when the flux is above the desired flux level by a positive hysteresis amount; and (iii) allowed to remain substantially constant or decrease slightly when the flux is between the positive and negative hysteresis values. Additional details concerning the structure and operation
15 of a hysteretic controller of the type described in connection with Figure 2C may be found in U.S. Patent No. 5,530,333 entitled "Control of an Inductive Load" by Michael J. Turner, issued on June 25, 1996, the entirety of which is hereby incorporated by reference.

Those of ordinary skill in the art having the benefit of this disclosure will
20 appreciate that the flux controller 21 of Figure 2C is but one of a number of various flux controllers that may be used to implement the flux control system of Figure 1.

Referring back to Figure 1, it may be noted that in the illustrated flux control system 10, a flux feedback signal from flux observer 16 provides an indication of the level of flux in the electro-magnetic system 15. The flux observer 16 may take the form
25 of a flux sensor (e.g., a Gaussmeter); a Hall-effect probe such as a thin-film Hall device; a SQUID (superconducting quantum interference device); or a flux calculator using, e.g., the flux curved gap measurement of a given coil.

For systems in which the phase coils of electro-magnetic system 10 are energized such that there are regular periods during which each phase coil experiences a zero flux
30 condition (i.e., each coil has zero flux in it for a non-zero interval), the flux associated with each coil may be estimated by an open-loop flux observer that is reset to zero during a known zero flux interval for that phase coil. Such an open-loop flux observer may provide an indication of the flux through application of the known relationship between the flux associated with a coil and the voltage applied and current in that coil. That
35 known relationship is reflected in Equation 1 below:

-5 Equation 1: Flux = Integral of $[V_{\text{phase}_n}(t) - i_{\text{phase}_n}(t) \cdot R] / Nt$
 where $V_{\text{phase}_n}(t)$ is a signal corresponding to the phase coil voltage as a function of time; $i_{\text{phase}_n}(t)$ is a signal corresponding to the phase coil current as a function of time; R is a value corresponding to the phase coil resistance; and Nt is the number of turns comprising the phase coil.

10 A conventional open-loop integrator may be used to determine the approximate flux for each phase coil. To avoid drift problems, the open-loop flux integrator may be reset to zero during known zero flux conditions to minimize the build-up of uncertainty in the integrator over time. The reset of the integrator may occur either on a timed basis (where the zero flux conditions occur at known time intervals) or the integrator may be a
 15 simple clamped integrator. When the electro-magnetic system 15 is energized such that only unipolar flux is established in the system, a clamped integrator that is clamped to zero may be used .

Figure 3A generally illustrates an exemplary embodiment of an open-loop flux observer 30 that may be used in the control system 10 illustrated in Figure 1. Referring to Figure 3A, the exemplary open-loop flux observer comprises a clamped integrator circuit 31 that receives as its input a signal that is equal to the sum of four voltage input signals. The four voltage input signals that determine the input to the integrator circuit 31 are, from top-to-bottom in Figure 3: (i) a $+V_{\text{INTCP}}$ voltage that corresponds to a constant voltage drop that is associated with the operating of the power switching devices
 20 17 and 18; (ii) a voltage signal corresponding to the magnitude of the phase current i ; (iii) a $+V_{\text{DC}}$ signal that is switchably coupled to the input of the inverter 31; and (iv) a $-V_{\text{DC}}$ signal that is switchably coupled to the input of the inverter 31. The $+V_{\text{DC}}$ and $-V_{\text{DC}}$ signals correspond to DC voltage levels that are related, in a known manner, to the positive and negative levels associated with the high voltage V_{HDC} that is applied to the
 30 phase coil of system 15. Typically, the $+V_{\text{DC}}$ and $-V_{\text{DC}}$ signals will be proportionally less than the $+V_{\text{HDC}}$ and $-V_{\text{HDC}}$ signals associated with the high voltage DC bus.

In the embodiment of Figure 3A, the $+V_{\text{DC}}$ signal is coupled to the input to integrator 31 via a controlled switch 32a that is rendered conductive when both the SU and SL signals are logic low (i.e., when the switching arrangement coupled to the phase
 35 coil is actuated such that the $+V_{\text{HDC}}$ bus is applied to the phase coil). In a similar

-5 manner, the $-V_{DC}$ signal is coupled to the input to integrator 31 via a controlled switch 32b that is rendered conductive when both the SU and SL signals are logic high (i.e., when the switching arrangement coupled to the phase coil is actuated such that the $-V_{HDC}$ bus is applied to the phase coil). The output of the clamped integrator Figure 31 is $-1*$ the flux (the signal is inverted). An amp with gain = -1 can be used at the output of the
10 clamped integrator to see the flux estimate. The inversion of the flux estimate is taken advantage of at the flux controller error amplifier. The error amplifier is a summing amp with the flux ref and flux estimate as inputs resulting in K gain (flux ref - flux estimate) at its output.

Because of the known relationship between the $+V_{DC}$ and $-V_{DC}$ signals and the
15 V_{HDC} bus, the voltage appearing at the input to the integrator 31 will correspond directly to the voltage that is applied to the phase coil. As such, an integration of the input voltage applied to an integrator will yield a signal that directly corresponds to the flux in the electro-magnetic system 15. The circuit shown has an output of flux estimate clamped >0 .

20 The use of switching devices 32a and 32b and the $+V_{DC}$ and $-V_{DC}$ signals to provide a signal representing the actual voltage applied to the phase coil is believed to be beneficial because the magnitude of the actual DC bus value is typically relative high (on the order of several hundred volts or more). As such, it would take large and costly components to directly integrate the relatively high voltages that are applied to the phase
25 coil. By using the approach of Figure 3A, less expensive, lower voltage devices may be used to provide an accurate indication of the flux in the system 15. Those of ordinary skill in the art having the benefit of this disclosure will appreciate that the actual voltages applied to the phase coil could be used to generate the input voltage for integrator 31. Alternately, search coils using a proportion of the phase voltage could be used and
30 integrated directly from the coil.

In the exemplary circuit of Figure 3A, the phase current is applied to a resistor 33 to provide a voltage signal that is intended to correct the input to integrator 31 for coil resistance. The value of resistor 33 used for the correction operation described above may be selected in a number of different ways. For a relatively simple correction factor,
35 the value of resistor 33 may be selected as an unchanging value that represents an

-5 estimate of the phase coil resistance over the expected operation conditions of the associated electro-magnetic system 15. Because R will vary with temperature and other operating factors, the selected R value will only be an approximate estimate of the actual R value for each phase windings. The current compensation can be improved if the R value is measured/estimated/calculated through the use of a thermal model and electrical
10 measurements or techniques currently used to estimate actual resistances, such as DC voltage injection.

Referring back to Figure 3A, it will be noted that, even through the drive switching, signals SU and SL are used to develop a low-voltage signal corresponding to the high-voltage signal actually applied to the phase coil, the current used to derive the
15 current-correction factor is the actual phase current i , not the switch currents. The actual phase current should be used to provide a more accurate current-correction factor since the switch current will not necessarily correspond to the phase current. In embodiments where the actual voltages applied to the phase coils are estimated though the use of drive switching signals and a low-voltage bus, the current-correction factor will have to be
20 appropriately scaled prior to subtracting the current-correction factor from the voltage corresponding to the voltage applied to the phase coils.

While true integrators may be used to obtain an estimation of the flux in system 15 as described in connection with Figure 3A, in many applications a more simplistic approach may be used. Particularly, when the flux in the system 15 is bi-polar zero
25 mean (discontinuous or continuous), the flux of the system may be approximately estimated by simply low-pass filtering the voltage applied to the phase coil ($V - iR$) (or low-pass filtering a voltage that like the voltage applied to integrator 31 of Figure 3A corresponds to the phase coil voltage). Such estimating of the flux of the system 15 through the use of low-pass filters is beneficial in certain applications because it may
30 minimize the drift and random walk problems associated with certain integrators. Figure 3B generally illustrates such an approach where a signal corresponding to the phase coil voltage (which may be corrected for the coil resistance) is applied to a low-pass filter 34 to provide a signal corresponding to the flux associated with the phase coil. The provided signal will also reflect a device voltage drop that always opposes the driving
35 voltage and would change sign in applications involving bi-polar excitation currents.

-5 When low-pass filters are used in place of integrators to estimate the flux of a given phase coil, the time constant of the filter should be higher than the period associated with the fundamental frequency of flux excitation for that coil. For example, if the phase coil is being energized at a fundamental frequency of 100 Hz (a period of 10 msec), the time constant for the low-pass filter for that phase coil should be
10 approximately 50 msec. or greater. Given the approximately 5:1 ratio (or greater) of the filter time constant to the voltage fundamental frequency and the zero average voltage of each coil voltage, the low-pass filters will approximately integrate the coil voltage to provide a useful estimate of the coil fluxes.

 The novel flux control system 10, and its various components, described above
15 in connection with Figures 1-3B, may be beneficially used in a number of different applications. For example, the flux control system 10 may be used to control the flux in a rotating electric machine, such as a conventional induction motor, universal motor, a switched reluctance motor or a permanent magnet motor or hybrid motor (e.g., PM and SR). The novel flux control system described herein may also be used in various
20 calibration devices in which the flux passing through a core must be controlled to a predetermined desirable level. Still further, the flux control system described herein may be used to control electro-magnetic actuating devices wherein the movement of a movable member is controlled through controlling the flux passing through one or more paramagnetic cores.

25 Figure 4 generally illustrates an electro-magnetic actuator 40 that may be used with the novel flux control system 10 described above. In general, the electro-magnetic actuator 40 comprises a stationary outer assembly 41 and a movable member positioned within a bore defined by the stationary assembly 41. In the illustrated embodiment, the stationary outer assembly 41 comprises three, substantially identical, magnetically
30 uncoupled flux generators comprising E-cores 43A, 43B and 43C. Each E-core comprises a stack of substantially identical laminations of a paramagnetic material (e.g., steel) that defines an E-shaped core having a central arm and two secondary arms, where the secondary arms are positioned on either side of the central arm. A yoke portion couples the central arm to the secondary arms. In the illustrated embodiment, for each E-
35 core, the width of the central arm is greater than the width of the secondary arms. In one

5 embodiment, for each E-core, the widths of the two secondary arms are substantially identical and are approximately one-half, or slightly less than one-half, of the width of the central arm. In general, the same construction techniques used to construct the stator cores of switched reluctance machines may be used to construct the E-cores 43A, 43B and 43C.

10 Positioned about the central arms of each of the E-cores 43A, 43B and 43C is a phase coil. In the illustrated embodiments, each of the phase coils A, B and C has the same number of turns and is formed in the same manner such that the three phase coils A, B and C are "symmetric."

15 Each phase coil is positioned about the central arm of its respective E-core such that, when electrical energy is applied to the phase coil, a current will be established in the phase coil that will establish a flux through the E-core. Approximations of the flux paths that will be established when the phase coils A, B and C of the E-cores 43A, 43B and 43C are provided by the curved lines in Figure 4. As reflected in the figure, the flux paths for the three E-cores are substantially identical and the flux path of each E-core
20 defines a central flux path through the central arm and two secondary flux paths through the secondary arms.

 Referring again to Figure 4, it may be noted that the arrangement of the three E-cores, 43A, 43B and 43C, is such that a generally triangular bore is defined by the E-cores. Positioned within this bore is a substantially triangular shaped movable member
25 42. In the illustrated embodiment, movable member 42 comprises a stack of substantially identical laminations of paramagnetic material (e.g., steel), although alternate embodiments are envisioned wherein the movable member includes permanent magnets (induction coils) or electro-magnetics.

30 As those of ordinary skill in the art having the benefit of this disclosure will appreciate, in the electro-magnetic actuator 40 of Figure 4 energization of one of the phase coils of one of the E-cores will produce a force on the movable member tending to cause movement of the movable member towards the energized E-core. This is because whenever a phase coil is energized, the movable member will tend to move to a position where the reluctance of the energized phase coil is minimized. Thus, if the phase A coil

5 associated with E-core 43A is energized, the movable member 42 will tend to move downwards towards the E-core 43A to minimize the reluctance of the energized A coil.

In the illustrated embodiment of Figure 4, the three E-cores 43A, 43B and 43C are arranged such that movement of the movable member may be controlled along two degrees of freedom. For example, using the X, Y reference indicators of Figure 4, the
10 movable member may be controlled to move in both the positive and negative X direction (a first degree of freedom) and in the positive and negative Y direction (a second degree of freedom) as well as along any path defined by X and Y points. Thus, the use of the three E-cores allows for the control of the movable member along two degrees of freedom.

15 While the particular actuator of Figure 4 allows for the control of the movable member along two degrees of freedom, those of ordinary skill in the art will appreciate that different numbers and arrangements of E-cores could be used to control movement along more or less degrees of freedom. For example, if an actuator were desired that was capable of moving along only one degree of freedom (e.g., along the positive and
20 negative X-axis only), then a substantially rectangular movable member could be used with only two E-cores. In general, when the movement of the movable member is caused by the tendency of the movable member to move to a position where the reluctance of an energized coil is minimized, to control N degrees of freedom, N+1 phase coils will be required.

25 In alternate embodiments where permanent-magnets or electro-magnets are positioned on the movable member (and, thus, where energization of one coil with either positive or negative current can produce both positive and negative forces along one degree of freedom), only N coils are required to control N degrees of freedom. Referring back to the actuator 40 of Figure 4, it may be noted that the flux paths
30 associated with the three E-cores 43A, 43B and 43C are independent of one another. In other words, the three illustrated E-cores are "magnetically uncoupled." One advantage of this characteristic is that the flux in each of the E-cores may be controlled independently of the flux in the other E-cores. Further, in the embodiment of Figure 4, the phase coils A, B and C associated with the three E-cores are separately energizable.
35 In other words, the phase coils are "electrically uncoupled." As such, the phase currents

5 in each phase coil can be controlled independently of the currents in the other phase coils. As explained in more detail below, this ability to independently control the flux and the current in each E-core independent of the flux and currents in the other E-cores is advantageous in many respects.

Referring back to Figure 4, it may be shown that for each E-core, the force exerted on the
 10 movable member tending to move the member towards the energized E-core is proportional to the square of the flux passing through the central arm of the E-core and generally corresponds to the following Equation 2:

$$\frac{1}{2 * \mu_0 * S} (flux^2)$$

15 where μ_0 is a constant reflective of the magnetic permeability of air, S is a value corresponding to the cross-sectional area of the central arm of the E-core that is parallel to a face of movable member 42, and flux is a signal corresponding the flux in the E-core of interest. The flux value may be provided by a flux observer of the type described above in connection with the description of flux observer 16.

20 Using matrix representations, the relationship between the fluxes in the three E-cores 43A, 43B and 43A and the forces exerted on the movable tending to move the movable member towards the E-cores 43A, 43B and 43C may be represented by Matrix Equation 1:

$$\begin{matrix} FA & & 1 & 0 & 0 & & flux_A^2 \\ 25 & FB & = & (1/[2*\mu_0*S]) & * & 0 & 1 & 0 & * & flux_B^2 \\ & FC & & & & 0 & 0 & 1 & & flux_C^2 \end{matrix}$$

where FA, FB and FC represent the forces tending to move movable member 42 towards the central arms of the E-cores 43A, 43B and 43C, respectively, and flux A, flux B and flux C represent the actual or estimated fluxes in the corresponding E-cores.

30 Through simple geometric calculations, the forces that will be exerted on the movable member may be transformed from FA, FB and FC coordinates to forces in X, and Y coordinates using Matrix Equation 2:

$$\begin{matrix} FX = & 0 & \text{Sqrt}(3)/2 & -\text{Sqrt}(3)/2 & * & FA; & FA, FB, FC \geq 0 \\ FY & -1 & 1/2 & 1/2 & & FB \\ 35 & & & & & FC \end{matrix}$$

5 It may be appreciated from Matrix Equations Nos. 1 and 2 that for a given arbitrary
desired force in terms of an appropriate reference frame (e.g., FX and FY), there are a
significant number, indeed potentially an infinite number, of flux_A, flux_B and flux_C
solutions that are capable of producing that desired force. Further, because of the
uncoupled nature of the E-cores and phase coils of the actuator 40 of Figure 4, there are
10 no constraints that render any of these potentially infinite solutions illegal. As such,
because of the nature of the illustrated actuator, the optimal flux_A, flux_B and flux_C
solution can be selected. Once the desired flux solution is selected, it can be
implemented though the use of flux control systems 10 of the type described above in
connection with Figures 1-3A. In general, a separate flux control system 10 will be
15 required to control the flux in each of the three E-cores 43A, 43B and 43C.
In general, one optimum "force-to-flux" solution or transformation for converting a
desired arbitrary X, Y force to the flux_A, flux_B and flux_C values necessary to
produce that force will be the solution that minimizes the net system flux and, thus,
minimizes the amount of energy required to establish that flux. Such a solution will
20 generally provide the most energy-efficient approach for establishing the desired force.
Further, for many electro-magnetic actuators, appropriate force-to-flux transformations
will exist that require operation of the actuators such that discontinuous unipolar flux is
established in the core or cores of the actuators. Such discontinuous flux operation
allows for the use of the beneficial open-loop flux observers described above. One
25 advantage of the novel electro-magnetic actuator illustrated in Figure 4 is that the optimal
force-to-flux transformation requires operation of the actuator such that discontinuous
unipolar flux is established in the three E-cores 43A, 43B and 43C during operation of
the actuator.

The optimal force-to-flux transformation for a given system may be derived by:

- 30 (i) establishing the relationship between the forces associated with the various actuator
elements (e.g., the E-cores) and the fluxes associated with those actuator elements (e.g.,
determining the relationship reflected by Matrix Equation 1); (ii) establishing the
relationship between the desired forces in a given reference frame (e.g., X, Y) and the
forces associated with the various actuator elements (e.g., determining the relationship
35 reflected by Matrix Equation 2); and (iii) solving for the actuator element fluxes in terms

5 of the desired forces in the given reference frame and selecting the solution that is the minimum norm solution. While any minimum norm solution may be used, it has been found beneficial to select the force-to-flux solution or transformation that is the minimum Euclidean norm solution. The concept of a minimum Euclidean norm solution will be understood by those of ordinary skill in the art and is generally discussed at page 10 166 of *Modern Control Theory* (3rd ed.) by William L. Brogen.

Once the desired force-to-flux transformation for a given system is established, it can be implemented in practice through a force control system. One exemplary embodiment of such a force control system is illustrated in Figure 5.

Referring to Figure 5, a force control system 50 is illustrated that includes an electro-
15 magnetic actuator 40, of the type illustrated in Figure 4 that is energized by a flux controller 12' that receives as input desired flux commands, flux_A_cmd, flux_B_cmd, and flux_C_cmd and flux feedback signals flux_A_est, flux_B_est and flux_C_est. The flux estimate commands are provided by a flux estimator 16' that, on a per phase coil basis, may take the form of any of the flux observers described above in connection with
20 flux observer 16 of Figure 1. The flux controller 12', on a per-phase basis, compares the flux command to the flux estimate at a comparator 19', amplifies the error signal at amplifier 20' and generates appropriate phase coil energization signals through use of a energization control circuit 21.' The construction of controller 12' may -- on a per-phase basis -- follow the description provided above in connection with the flux
25 controller 12 of Figure 1. The drive circuitry required to energize the phase coils A, B and C is not illustrated in Figure 5, although it will be apparent to those of ordinary skill in the art having the benefit of this disclosure.

Coupled to the flux controller 12' is a force-to-flux controller 51 that receives at its inputs desired force commands in a given reference frame (the X, Y reference frame in
30 Figure 5) and provides at its output appropriate flux commands in terms of flux_A_cmd, flux_B_cmd and flux_C_cmd. The flux commands are received and acted upon by the flux controller 12' in a manner similar to that previously described in connection with flux controller 12 of Figure 1.

While the force-to-flux controller 51 may be constructed from exclusively analog
35 circuits, in the illustrated embodiment of Figure 5, force-to-flux controller 51 includes a

5 digital circuit, such as a microprocessor or microcontroller, that is appropriately
programmed to implement a desired force-to-flux transformation. The use of a digital
circuit to construct the force-to-flux controller can be beneficial, in that, the force-to-flux
transformation may be readily implemented through mathematical relationships that are
easily implemented in digital circuitry and, in that, the use of digital circuitry allows for
10 easy modification of the force-to-flux transformation. Moreover, when digital circuitry
is used to implement the force-to-flux controller 51, the input force commands may be
either digital or analog. If analog, some form of analog-to-digital conversion will be
required to transform the force commands into appropriate digital values. Similarly,
when a digital force-to-flux controller 51 is used, the desired flux commands -- if digital
15 -- may be required to be converted to analog signals if an analog flux controller is used.
The construction and programming of a digital force-to-flux controller 51 will be within
the ability of one of ordinary skill in the art having the benefit of this disclosure.
Figures 6A-6D illustrate, through the use of a pseudo-code block, one exemplary form of
a force-to flux controller 51 that may be implemented through the use of a programmed
20 microcontroller or microprocessor. The force-to-flux transformation implemented by the
controller exemplified by Figures 6A-6D corresponds to the minimum Euclidean norm
solution for the actuator 40 of Figure 4. It will be appreciated by those of ordinary skill
in the art having the benefit of this disclosure that while the description of controller 51
is in terms of discrete pseudo-code function blocks, the controller may be implemented
25 through one or more programmed processors, analog circuits, or a combination of the
two.

Referring to Figure 6A, the general operation of force-to-flux controller 51 is divided
into three high level function blocks 60, 61, and 62. In general, function block 60,
labeled FXY_to_FABC, receives the desired force commands in terms of a given
30 reference frame (here the XY reference frame) and converts the force commands into
force commands that are commiserate with the physical arrangement of the actuator 40
(here the arrangement of E-cores 43A, 43B and 43C). The function block 61 receives the
force commands in terms of the arrangement of actuator 40 and converts those force
commands into flux commands that correspond to the phase coils of the actuator 40.
35 Function block 62 is an optional function block not required for all implementations of

5 controller 51 that receives the flux commands from block 61 and modifies the commands to ensure that each of the flux commands is zero for a finite time interval. The use of the “flux_zeroing” block 62 ensures that the fluxes in actuator 40 are discontinuous, thus, allowed for the use of some of the beneficial forms of flux observers described above in connection with flux observer 16. Each function block will be discussed in more detail
10 below.

Figures 6B1-6B4 illustrate the structure and operation of function block 60 that transforms the input force commands in terms of FX and FY into force commands in terms of the FA, FB and FC forces that can be directly generated by actuator 40. In the illustrated embodiment, the function block 60 first uses the FX and FY commands to
15 derive six intermediary control signals F_a1, F_a2, F_b1, F_b2, F_c1, and F_c2 at function blocks 63a, 63b and 63c. Function blocks 63a-63c each essentially multiply the FX and FY commands by a 2X2 state matrix that, on a per-phase coil basis, implements a plus or minus inverse of each possible partition of Matrix Equation 2. The proper solution is then selected from the possible solutions.. The 2X2 state matrices used by
20 function blocks 63a-63c are illustrated, respectively, in Figures 6B2, 6B3 and 6B4. Each of function blocks 63a, 63b and 63c provides two output force values because the implementation of the inverse of Matrix Equation 2 will produce two solutions for each of FA, FB and FC. The appropriate solution for the system is selected by function blocks 64a, 64b and 64c.

25 Referring back to figure 6B1, each of function blocks 64a, 64b and 64c, receives as its inputs the two force solutions from its associated function block 63a, 63b or 63c. Because of the nature of the function blocks 63a, 63b and 63c, at least one of the force solutions will be positive. Function blocks 64a, 64b and 64c first eliminate all negative force solutions by adjusting the corresponding intermediary force command to zero and
30 then select the greater of the two adjusted force commands. In the particular embodiment of Figure 6B1, the selected force commands from function block 64a, 64b and 64c are limited to a peak value by function block 65 to produce the limited, per phase coil force commands Fa, Fb and Fc. Embodiments are envisioned wherein the limiting function implemented by block 65 is eliminated or is implemented as a function
35 of some other system parameter.

5 Referring back to Figure 6A, once the Fa, Fb and Fc commands are generated by function block 60 those commands are processed by function block 61 to produce the flux commands flux_A_volts, flux_B_volts, and flux_C_volts. Function block 61 is illustrated in greater detail in Figure 6C. The operation of function block 61 represents a straightforward implementation of the bounded (>0) inverse of Matrix Equation 1 on a
 10 per phase coil basis. Specifically, any negative Fa, Fb and Fc commands are adjusted to zero since the actuator 40 cannot produce negative force. From the adjusted force commands, FA, FB and FC, the required per-phase coil flux is decided by taking the square root of the adjusted force command for a given phase multiplied by a constant value that corresponds to

15
$$\sqrt{2\mu_o S}$$

See Equation 2, above. The outputs of function block 61 are the flux command signals flux_A_volts, flux_B_volts, and flux_C_volts.

In the particular embodiment of Figure 6A, the flux commands from function block 61
 20 are applied as inputs to a flux zeroing function block 61 that ensures that the flux commands are zero for a finite time interval. The use of such a flux zeroing block is not required for most applications and is only essential for linear X motion. The precise form of function block 62 will vary slightly depending on whether the digital force-to-flux controller 51 is operating on a sampling basis or on a continuous basis. Figure 6D1
 25 illustrates an exemplary construction of function block 62 for a digital controller that samples the various control parameter values on a regular basis. Figure 6D2 illustrates a similar function block 62' for a continuously operating controller 51.

Referring to both Figures 6D1 and 6D2, the function block 62 and 62' receive the flux commands flux_A_volts, flux_B_volts, and flux_C_volts and then, in function blocks
 30 66a, 66b and 66c for Figure 6D1 and function blocks 66a', 66b' and 66c' for Figure 6D2, generate an average flux command signal that corresponds to a running average of the flux command signal over a given time interval. The different manner in which these average flux command values are determined constitutes the most significant difference between the sampling controller reflected in Figure 6D1 and the continuous controller

5 reflected in Figure 6D2. Any form of digital or analog averaging filter with the appropriate lime constant could be used.

Both the actual flux commands and the averaged flux commands are provided to a function block 67. Function block 67 compares the actual flux commands to a fraction of the average flux commands and, if the actual flux command for a given phase is less
10 than a fraction of the average flux command, adjusts the flux command to be a minimum flux value. If the actual flux command is greater than the fraction of the average flux command, then the actual flux command is not adjusted. Thus, the outputs from function block 67 constitute the flux command outputs flux_A_volts, flux_B_volts, and flux_C_volts from the force-to-flux controller 51. Referring to Figure 5, these outputs
15 are then processed by the flux controller 12' to control the flux in the actuator 40.

Those of ordinary skill in the art having the benefit of this disclosure will recognize that the particular force-to-flux transformation reflected in Figures 6A-6D is but one example of a force-to-flux transformation that may be implemented by a force-to-flux controller constructed according to certain teachings of this disclosure. For example, one alternate
20 force-to-flux transformation may be based upon an angle described by the FX and FY force commands and the physical arrangement of the E-cores comprising actuator 40.

Figure 7A generally illustrates a representation of which of the phase coils of actuator 40 should be energized to produce force for a desired force vector in terms of X and Y.

Basically, Figure 7A "windows" which coils will be on as a function of the direction of
25 the desired force in terms of a vector comprising FX and FY components. In this force-to-flux transformation as in the previous, only two phase coils are energized at any given time. Referring to Figure 7A, it may be noted that any commanded force corresponding to an angle of between 30 degrees and 150 degrees may be generated by a combination of FB and FC forces, with zero FA force. Similarly, any desired force having a direction
30 between 150 degrees and -90 degrees can be generated from FA and FC forces with no FB force and any desired force having a vector direction between -90 degrees and 30 degrees can be generated with FA and FB forces and no FC forces.

Figure 7B generally illustrates a function block for generating the appropriate flux commands to implement the force-to-flux transformation reflected by Figure 7A. First,
35 the illustrated function block calculates the appropriate force angle as a function of the

- 5 FX and FY commands. Then, using that angle, the block determines which category of Figure 7A the angle falls in and, based on that determination, determines the appropriate flux commands for the two phase coils that are to be energized for that category. These generated flux commands are then applied to the flux controller 12' and the system operates as previously described.
- 10 Still further alternate force-to-flux transformations are envisioned. For example, the particular force-to-flux transformations described above occurred in the context of an actuator 40 having three uncoupled E-cores that is designed to control movement of the movable member 42 along two degrees of freedom. Alternate embodiments are possible where the actuator comprises only two E-cores arranged for linear movement of the
- 15 movable member. In such applications, the only input force command would be a FX (or FY command). Still further four E-cores could be used and FX and FY commands could be provided. Figures 8A-8C generally illustrate function blocks for a force-to-flux controller 80 that may be used in a two E-core linear system or with 4 coils, each set of two controlling one axis (degree of freedom).
- 20 Referring to Figure 8A, the illustrated controller 80 receives a FX force command and generates as outputs flux commands for the two phase coils, designated as A and B. In general, a function block 81 first transforms the FX command into FA and FB force commands corresponding to the linear actuator, and a function block 82 transforms these force commands into appropriate flux commands flux_A_volts and flux_B_volts.
- 25 Details of the function block 81 are provided in Figure 8B. In general, the function block 81 receives the FX command and, if the FX command is negative, assigns FA a zero value and FB a value equal to the magnitude of FX. Conversely, if FX is positive, the function block assigns FB a zero value and FA the absolute value of FX. The FA and FB commands are then limited to a peak value. The limited FA and FB commands are
- 30 provided by function block 81 to function block 82 which determines the appropriate flux commands, flux_A_volts and flux_B_volts.
- Function block 82 is illustrated in greater detail in Figure 8C. Referring to Figure 8C, the function block 82 basically sets the corresponding flux command if the force command is equal to or less than zero or calculates the appropriate flux command using

-5 the inverse of Equation 1. The flux commands flux_A_volts and flux_B_volts are then applied to an appropriate flux controller to energize the system.

The force control systems described above in connection with Figures 5-8C have several advantages not generally available from known systems for controlling an electro-magnetic actuator to produce a desired force. For example, in known control systems,
10 the control variable used to obtain a desired force is either the voltage or current applied to the phase coils. These systems are inherently limited because, if voltage control is used, the forces that will be produced will be a non-linear function of the controlled voltage. Such non-linear control problems are, in practice, difficult and costly to implement and do not allow for accommodation of changed operating conditions and/or
15 manufacturing tolerances. If current control is used, the system is open-loop unstable and, for reasonably acceptable performance, the non-linear characteristics of the actuator core must be addressed. This results in the same non-linearity difficulties associated with voltage control systems.

The use of a flux control system as described herein significantly reduces or eliminates
20 many of the difficulties associated with voltage or current control systems. This is because, when flux control is used, the force generated across each air gap of each actuator element is proportional to the square of the flux in the air gap. As such, non-linearities of the magnetic material and non-linearities in the electrical dynamics need not be considered to provide acceptable control. Thus, the force and flux control systems
25 described herein can be used to implement simpler and more efficient control schemes that are easier and less costly to design and implement. Further, when coupled with the use of a simple open-loop flux observer as described herein, flux control can result in an extremely efficient and elegant system.

While the force control system of Figure 5 allows for the efficient control of the force
30 exerted on the movable member 42 of actuator 40, in many applications it is the movement of the movable member (e.g., the position/velocity or trajectory of the movable member) -- not the forces exerted thereon -- that are desired to be controlled. For such applications, the system of Figure 5 can be enhanced to add a position/velocity control loop that generates the desired force commands FX and FY in such a manner that
35 the movement of the movable member is controlled in a desired manner. The

5 applications of a position/velocity control system of the type described above are numerous. For example, such a position/velocity control system may be used to construct electro-magnetic bearings, as well as shaking and sifting apparatus. One specific application of such a position/velocity controller is in the field of orbital welders. Such welders typically operate by driving a first part to be welded (e.g., a thermoplastic
10 part) with orbital motion relative to a second part to be welded such that relative movement of the first and second parts causes friction to heat the parts along the intersection thereof such that upon cessation of the relative motion, the parts will cool and be welded to one another.

In such welders, a first part is typically placed in a holder. A second part is similarly
15 placed in a holder. The parts are then held in forced engagement with one another along an interface between the parts and a drive is provided for driving the second part along a predetermined repetitive path relative to the first part so as to frictionally heat the parts along the interface such that, upon termination of the repetitive motion, the parts are welded together.

20 Conventional orbital welders are capable of moving the first part to be welded such that the relative movement between the parts is restricted to either linear or orbital movement. These restrictions on the movement of the welder are limiting, in that, for many applications, different and arbitrary relative movement is desired so that the relative movement of the parts to be welded can closely match the shape of the parts. Such
25 "shape-matching" can significantly increase the strength of the resultant weld. Through the use of the position/velocity control system described herein, a welding apparatus can be constructed that is capable of establishing arbitrary relative movement between parts to be welded, including linear movement, orbital movement, rotational movement, or any arbitrary movement of the part to be welded. Those of ordinary skill in the art will
30 appreciate that the position/velocity control system described herein is but one example of a control system that may be constructed according to the teachings contained herein and that other characteristics and combination of characteristics (e.g., acceleration, velocity, position, or any combination thereof) may be controlled.

Figure 9 provides a high-level block diagram of an exemplary position/velocity control
35 system 90 that may be used to construct a welding apparatus as described above.

-5 Although the following discussion is in the context of a welding apparatus, those of ordinary skill in the art having the benefit of this disclosure will appreciate that the disclosed position control system can be used to control the position/velocity of a movable member in other applications.

Referring to Figure 9, the position/velocity control system 90 is identical in many
10 respects to the force control system of Figure 5. Specifically, within the dashed box 50, the position/velocity control system 90 includes all of the components of the force control system 50 of Figure 5, all of which operate as described above in connection with Figure 5. Because the actuator 40 of the system is part of a large vibration welding machine, the movable member of the actuator may be coupled to an appropriate welding
15 horn or other appropriate welding tool (not illustrated).

In addition to including the components of the force control system 50, the position/velocity control 90 includes two additional main components. First, in the embodiment of Figure 9, the force command signals FX and FY are generated by a position/velocity controller 91. Position/velocity controller 91 receives at its inputs: (i)
20 position command signals 92 representing the desired position/velocity (or trajectory) of the movable member of actuator 40; and (ii) feedback signals from a position/velocity observer 93 that represent current position/velocity or trajectory information associated with the movable member of actuator 40. In general, position/velocity controller 91 compares the position/velocity commands with the position/velocity feedback
25 information to produce position/velocity error signals and uses these position/velocity error signals to generate the appropriate force commands that will tend to bring the movable member to the position/velocity indicated by the position/velocity commands 92, or to move along the trajectory defined by trajectory commands 92, when trajectory commands are provided.

30 The position/velocity controller 91 may take many forms depending on the manner in which the desired position/velocity and/or trajectory of the movable member is defined. In one embodiment, the position/velocity controller 91 may be constructed to control the position and velocity of the movable member of actuator 40 in terms of the position of the movable member in an X, Y reference frame and in terms of the velocity of the
35 movable member in terms of X and Y. In such a system, the two input position

5 commands provided to the position/velocity controller 91 will be in terms of X_cmd , X_dot_cmd (X velocity), Y_cmd and Y_dot_cmd (Y velocity) and the two feedback commands from the position/velocity observer 93 (described in more detail below) will be in terms of the actual or estimated X and Y positions and velocities of the movable member (e.g., X_act , X_dot_act , Y_act , Y_dot_act).

10 Like the force-to-flux controller 51 described above, the position/velocity controller 91 may be implemented through the use of a programmed digital processor, such as a microprocessor or a microcontroller. In certain applications, the position/velocity controller 91 may be implemented using the same programmed processor that issued to implement the force-to-flux controller. Analog implementations are also envisioned.

15 In operation, the position/velocity controller 91 receives the X , X_dot , Y , and Y_dot command signals from the position/velocity command generator and compared the command signals to feedback signals that represent the actual or estimated position and velocity of the movable member (X_act , X_dot_act , Y_act , Y_dot_act). As a result of this comparison of the instantaneous position and velocity command and feedback

20 signals, four error signals (eX , eY , eX_dot , and eY_dot) are generated corresponding to the differences between the command signals and feedback signals. The four error signals may then be multiplied by appropriate control gains that may be optimized for each application. The X error signals (eX and eX_dot) are then added together and the Y signals (eY and eY_dot) are added together to produce FX and FY command signals

25 required to position the movable member at the desired position and with the desired velocity. Before being provided to the force control system 50, the FX and FY force command may be band-pass filtered to reduce bias and reduce noise content. The filtered force command signals FX and FY are then provided to the force-to-flux controller 51 of the force control system 50. Depending on the parasitic modes of the

30 system and other factors, the filter and filtering operation may or may not be necessary. In one embodiment of the position/velocity controller 91, the feedback signals representing the X, Y position and velocity of the movable member of actuator 40 are generated through the use of a position/velocity observer 93 that includes conventional accelerometers that are positioned with respect to actuator 40 such that they can provide

35 X and Y acceleration information to controller 91. In that embodiment, the position and

5 velocity in terms of X and Y is derived by the position/velocity controller 91 using low-pass filters that are, for all practical purposes, at frequencies above 170 Hz; integrators. Using low-pass filters, instead of pure integrators, eliminates the drift and variance build-up problems of open-loop integrators. Exemplary function blocks for implementing such a position controller are provided in Figure 10A.

10 Referring to Figure 10A, the acceleration signals from the X (d^2_x/dt^2) and Y (d^2_y/dt^2) accelerometers of position/velocity observer 93 are applied as inputs to the function blocks designated as 100X and 100Y. When a digital controller 91 is used, any analog acceleration signals should be converted to digital values and the digital values should be applied as inputs to the controller 91.

15 Function blocks 100X and 100Y, respectively, include conventional mathematical transforms that transform the acceleration signals into estimations of the velocity of the movable member in terms of X and Y (e.g., X_{dot_est} and Y_{dot_est}). The X and Y velocity estimates are then applied, respectively, to function blocks 101X and 101Y that transform the velocity estimates into position/velocity estimates. The mathematical
20 nature of the transform is illustrated in Figure 10A. The X and Y velocity and position estimates are, respectively, applied as inputs to gain blocks 102X and 102Y and scaling blocks 103X and 103Y that adjust the estimate signals. The estimated position and velocity signals are then subtracted from the X and Y position and velocity command signals at function blocks 104X and 104Y to produce X and Y position and velocity error
25 signals. The X and Y error signals are combined by function blocks 105X and 105Y to produce FX and FY signals that are modified by a low-pass filter and gain multiplier combinations 106X and 106Y to produce the FX and FY commands that are used to control the system as described above.

The exemplary position/velocity controller of Figure 10A may be used in systems where
30 the acceleration information from position/velocity observer 93 is continuously sampled and the FX and FY commands are continuously generated. Alternate embodiments are envisioned wherein the operation of controller 91 is not constant but operates on sampled information. Function blocks for such a sampling controller 91 are illustrated in Figure 10B. In general, the controller 91 of Figure 10B is similar to that of Figure 10A except

5 that the mathematical nature of the filters and transforms has been adjusted to reflect the sampling nature of the controller.

In the examples of Figures 10A and 10B, the position/velocity observer 93 comprises X and Y accelerometers and the position and velocity estimates for the movable member of actuator 40 are derived from the outputs of the accelerometers. Alternate embodiments
10 are envisioned where conventional position sensors (e.g., proximity sensors) are used to sense the X and Y position directions. In such alternate embodiments, velocity information may be obtained using a reduced order observer, such as a standard deterministic observer, an integral error observer, or a Kalman Filter observer. In general, any type of full-order or reduced-order position/velocity observer 93 that can
15 provide position and velocity information about the movable member of actuator 40 may be used to construct position/velocity observer 93. In alternate embodiments, pick up coils could be used with a position observer. Pick up coils measure velocity.

In one embodiment, position/velocity observer 93 may be eliminated, and the position and velocity information about the movable member of actuator 40 may be obtained
20 from the electrical characteristics of actuator 40 itself. In embodiments, where the phase coils of actuator 40 are energized such that, at all times or at given times, at least one of the phase coils is unenergized, the unenergized coil may be used as a proximity sensor. In such an embodiment, the unenergized phase coil may be excited with high frequency flux pulses and the resulting current may be detected. The magnitude of that current will
25 have a straightforward algebraic relationship to the air gap magnitude of the flux. That air gap magnitude, when determined, will be completely deterministic of either the X or Y position.

Unfortunately, when the phase coils are required to provide a force vector that has a direction of between +30 degrees and +120 degrees (*see* Figure 7A), only the X position
30 can be determined from the unenergized coil. In such instances, the X position may be determined from the estimated or actual flux and current information. The relationship between the estimated flux and current is, again, straightforward and algebraic. In systems that have four phase coils, the position of the movable member could be determined entirely through analysis of the electrical characteristics of the unenergized
35 coils.

-5 Because the force-to-flux transformation used in the position/velocity control system of Figure 9 eliminates the non-linearity in the force production mechanism, the error signals generated and used by the position/velocity controller 91 have linear dynamics and the remainder of the control system may be designed using linear methods. Any conventional multi-input, multi-output linear control design methods can be used to tune
10 the system and, therefore, set the response of the system, such as pole-placement, LQG, robust, etc. This ability to instantaneously control the position and the velocity of the movable member is highly beneficial in vibration welding applications.

In one embodiment, pole placement is used to tune the control system where the closed-loop poles of the system are placed by the four control gains resulting in a proportional
15 control system. Although finite steady-state error and phase error between the X and Y commands will exist when this form of pole placement is used, the shape of the orbit of the movable member will not be affected.

Conventional vibration welding systems utilize an average-based control system in which the movable member of the system is controlled to move in either a circle or an
20 ellipse and the average radius of the circle or ellipse is controlled. When asymmetric welding tools are used or disturbances of the movable member are encountered, such average control systems cannot compensate quickly enough to stabilize the system. In contrast, the novel control system disclosed herein instantaneously controls the X position, the Y position, the X velocity and the Y velocity of the movable member.

25 Moreover, coupling of the X and Y motion due to tool asymmetries and load disturbances are rejected using instantaneous control.

When the position/velocity commands are provided in a stationary reference frame (e.g., X, Y) a slower average radius control loop may be placed around the instantaneous control loop to ensure zero steady-state error. Such an outer control loop is particularly
30 beneficial to ensure that the movable member follows the desired trajectory, even under overload conditions. In general, the average radius control loop produces an average radius error that is provided as an input to a PI control law controller. The PI control law will then eliminate any steady-state error, although phase error between the X and Y commands will still exist. Since the average radius will be a DC variable, the PI control
35 law controller will reject constant load disturbances. The output of the PI control law

-5 controller is then added to the command radius signal to increase the total radius command signals to the proportional instantaneous command signal.

In the particular embodiment illustrated in Figure 9, the input position/velocity commands are provided in terms of the desired position and velocity of the movable member of actuator 40 in terms of X and Y position and velocity. In many vibration
10 welding applications, the desired movement of the movable member will not correspond to arbitrary X and Y commands but will, instead, correspond to X and Y commands that will tend to produce elliptical movement of the movable member of actuator 40. For such applications, the X and Y position/velocity commands may be generated by a novel position/velocity command generator that generates the X and Y position and velocity
15 commands required to produce the desired elliptical trajectory. Such a position/velocity command generator would have its outputs coupled to the input of position/velocity controller 91.

Figure 11A generally illustrates one exemplary set of function blocks that may be used to implement an exemplary position/velocity command generator 110. Referring to the
20 figure, position/velocity command generator 110 receives at its inputs command signals that define a desired elliptical orbit for the movable member of actuator 40. In particular, the command signals received by the position/velocity command generator 110 are: (i) a major axis command ($r_command$) that corresponds to the major axis of the desired elliptical orbit along the X axis; (ii) a major-to-minor axis ratio command or eccentricity
25 command ($ecc_command$) that defines the ratio of the major axis along the X axis to the minor axis along the Y axis; (iii) an angle command ($angle_command$) that defines the angular displacement angle of the major axis of the desired trajectory from the X axis; and (iv) an operating frequency command (fc) which defines the frequency at which the movable member traverses the desired elliptical path.

30 Referring to Figure 11A, the various input commands described are filtered using the appropriate filters 111, 112, 113 and 114 illustrated in the figure. If an outer radius control loop is used as described above, the filtered radius command ($r_filtered$) may be modified using a radius error correction value at summing junction 115. The modified radius command (r_error_total) is then limited to fall within certain bounds at limiting
35 block 116 and the limited r command is applied to an elliptical transformation block.

5 The input operating frequency command is then converted, through function blocks 118, 119a and 119b into time changing angular values that are applied as inputs to the elliptical transform block 117. The other filtered input signals (ecc_filtered, angle_filtered) are applied directly to the elliptical transform block 117.

10 Elliptical transform block 117 receives the signals referenced above and generates the X and Y position and velocity commands (X_cmd, X_dot_cmd, Y_cmd, and Y_dot_cmd) using the mathematical relationships set forth in Figure 11A.

Figure 11A illustrated function blocks that may be used to implement a position/velocity command generator 110 that operates on a continuous basis in response to continuous input signals. Figure 11B illustrates a similar position/velocity command generator 110' that operates on a sampling basis to produce the appropriate position/velocity commands in response to sampled input signals. As those of ordinary skill in the art having the benefit of this disclosure will appreciate, position/velocity command generator 110 is substantially identical to position/velocity command generator 110', with the exceptions being that the filters 111', 112', 113' and 114' of generator 110' vary from filters 111, 112, 113, and 114.

Those of ordinary skill in the art having the benefit of this disclosure will appreciate that position/velocity commands different from those described above could be applied to the position/velocity control system of Figure 9. In general, any appropriate position/velocity command signals may be expanded to Fourier Series to describe any periodic waveforms that, in their limit, may be described as square waves. For example, the input X and Y position and velocity commands could be generated as a function of time according to the following relationships: $X_cmd(t) = r \cdot \cos(\omega \cdot t)$; $X_dot_cmd(t) = -r \cdot \omega \cdot \sin(\omega \cdot t)$; $Y_cmd(t) = r \cdot ecc \cdot \sin(\omega \cdot t)$; and $Y_dot_cmd(t) = r \cdot ecc \cdot \omega \cdot \cos(\omega \cdot t)$; where r is the major axis, ecc is the desired eccentricity, omega corresponds to the desired operating frequency and t is time.

Further, the desired elliptical trajectory described above could be made to match a "super ellipse" defined by $((X/A)^n + (Y/B)^n = r$, where n is an integer ≥ 2 . Such a super ellipse trajectory could be traversed at an angular velocity of omega with Fourier Series of the command reference signals. The position/velocity control system would

5 then attempt to track the position/velocity waveforms to the limit of the drives capabilities and band width.

Figures 12A-12D illustrate the operation of a position/velocity controller of the type described above in connection with Figure 9. Each figure illustrates the X and Y movement of the movable member of actuator 40, the FX and FY commands, the flux commands and the flux values for the three phase coils A, B and C. Figure 12A
10 illustrates the operation of the system for linear movement along the X axis at a no-load condition and Figure 12B illustrates the operation of the system for the same type of movement under full load conditions. In a similar manner, Figures 12C and 12D illustrate operation of the system for circular motion at, respectively, no-load and full-
15 load conditions.

As Figures 12A-12D make clear, the flux established in the actuator 40 by a flux controller constructed as described herein will be discontinuous and will closely track the flux commands, both for no-load and full-load conditions.

The position/velocity control systems described above are all based on a stationary
20 reference frame (e.g., X and Y). Alternate embodiments are envisioned wherein the reference frame used for control purposes is based on rotating coordinates. The use of such a rotating reference frame can, for a given performance goal, reduce the required sampling rate, and provide for improved phase and amplitude tracking. Furthermore, the use of such a rotating reference frame can minimize and/or ensure a zero steady-state
25 error through the use of a PI control law controller since, for such a reference frame, the control variables used by such a "rotating" control system are DC quantities.

In accordance with one embodiment of the present invention, a rotating position/velocity controller may be constructed that is based on a QD rotating reference frame where the movement of the movable member is defined, not in terms of X and Y position and
30 velocity, but in terms of rotating vectors Q and D each having a corresponding vector whose elements are PC quantities at steady state. Such a QD position/velocity control system functions in a similar manner to that described above in connection with the XY control system with the general exceptions described below.

When a rotating position/velocity controller is used, both the position/velocity
35 commands to the position/velocity controller and the feedback signals from

5 position/velocity observer 93 reflecting the position/velocity of the movable member of the actuator may be provided in terms of the QD reference. Alternately, the position/velocity commands and feedback signals may be provided in terms of XY position and velocity in which case the position/velocity commands and signals must be transformed from the XY reference frame to the QD reference frame. These
10 transformations may be accomplished using an appropriately programmed digital processor.

Figure 13 generally illustrates one form of a QD control system 130 constructed according to certain aspects of the present invention. In general, the QD control system includes a QD controller 132 that receives at its inputs position command signals that
15 define the desired movement of the movable member of actuator 40 in a pre-defined QD reference frame. Specifically, in the illustrated embodiment, the input QD position commands are: (i) q_cmd , defining the desired instantaneous magnitude and sign of the Q vector; (ii) d_cmd , defining the desired instantaneous magnitude and sign of the desired D vector; (iii) q_dot_cmd , defining desired rate of change in the magnitude of the
20 Q vector; (iv) d_dot_ref , defining desired rate of change in the magnitude of the D vector; and (v) fc , defining the desired operating frequency of the system. In general, Q and D are quasi static variables who may be > 0 or < 0 .

The exemplary controller 130 of Figure 13 is adapted for use in an orbital welding apparatus and, as such, is specially adapted to control elliptical movement of the movable
25 member of actuator 40. As such, the QD control operations are performed in a rotating, elliptical QD reference frame. To define the appropriate rotating elliptical QD reference frame, QD controller 130 requires two additional variables. The first variable ($ecc_command$), like the $ecc_command$ discussed above, defines the ratio of the ellipse major axis along the X axis to the minor axis, along the Y axis. The second variable
30 (δ) defines the angular extent to which the major axis of the rotating elliptical frame is offset from the stationary X axis.

Other inputs to the QD controller 132 include feedback signals that provide information about the position/velocity of the movable member of actuator 40. In general, these signals are provided by a position/velocity observer 93 that, like position/velocity
35 observer 93 discussed above, includes X and Y accelerometers. The X and Y

-5 position/velocity information from position/velocity observer 93 is converted into q , d , q_dot and d_dot signals corresponding to the QD parameters of the moveable member in the appropriate rotating elliptical QD reference frame. This transformation is accomplished by a XY-to-QD transform operation, reflected by block 131. The QD position/velocity information from block 131 is provided as another set of inputs to the
10 QD controller 132. The QD controller then compares the QD information for the movable member with the command QD information to produce QD error signals that are used to generate desired Q and D force commands, FQ and FD. These force commands are then transformed into corresponding force commands in the FX and FY reference frame by a QD-to-XY transformation operation, reflected by block 133. The
15 FX and FY signals are then applied to a force control system 50 that controls the forces applied to the actuator 40 in the manner previously described in connection with the force control system of Figure 5.

The QD controller 132 of Figure 13, and the blocks 131 and 133 may be implemented through the use of a programmed digital processor. Figures 14A-14D generally illustrate
20 function blocks that may be used to implement an exemplary QD controller 132 and blocks 131 and 133. The illustrated controller operates on a continuous basis, although those of ordinary skill in the art having the benefit of this disclosure will appreciate that a sampling QD controller can also be constructed from the teachings provided herein.

Referring to Figure 14A, an overview of the QD controller 132 and blocks 131 and 133
25 is provided. In the illustrated embodiment, the illustrated QD controller receives X and Y acceleration information from a position/velocity observer 93 comprising X and Y accelerometers. The X and Y acceleration information is processed by function blocks 100X, 100Y, 101X and 101Y to produce X_est , X_dot_est , Y_est and Y_dot_est signals in the manner previously described in connection with Figure 10A. The X Y estimated
30 position and velocity information is then provided as an input to a transformation function block 140 that transforms the XY information from the function blocks 101X and 101Y into the appropriate rotating, elliptical QD reference frame. Figure 14C provides a more detailed illustration of the operation of function block 140.

Alternate embodiments are envisioned wherein X, X_dot , Y, and Y_dot are measured
35 directly, estimated as described above, or estimated from either X, Y or X_dot , Y_dot .

-5 Still further aX , aY could be directly transformed into aQ , aD and an observer for Q , D_{dot} , D , D_{dot} could be used in the rotating reference frame.

Referring to Figure 14C, the function block 140 comprises three sub-function blocks 141, 142 and 143. These function blocks transform the $X Y$ information from position/velocity observer 93 into QD information in the desired rotating elliptical

10 reference frame. Initially, the X_{est} , X_{dot_est} , Y_{est} and Y_{dot_est} signals are provided to function block 141 that transforms the XY signals into corresponding signals in an XY reference frame that is rotated from the standard stationary reference frame by an amount corresponding to the value of the delta variable described above. The outputs of function block 141 thus constitute XY position and velocity data in an XY reference

15 frame that is offset from the stationary XY reference frame by an angular amount defined by the input variable delta.

The delta-adjusted XY information from function block 141 is applied as an input to function block 142 that receives the delta-adjusted XY signals and transforms those signals to XY signals in an XY reference frame that has been adjusted to accommodate

20 the eccentricity of the desired elliptical reference frame. Generally, function block 142 adjusts the delta-adjusted XY signals for the differences between the major X axis and major Y axis of the ellipse. As reflected in Figure 14C, one input to function block 142 is the `ecc_command`.

The delta-and-ecc-adjusted XY signals from function block 142 (X_c , X_{dot_c} , Y_c and

25 Y_{dot_c}) are applied as inputs to function block 143. In general, function block 143 transforms its inputs (in terms of a stationary XY reference frame) into QD signals in terms of a rotating circular reference frame. Because the inputs to XY -circular QD function block 143 are delta-and-ecc adjusted XY signals, however, the q_{est} , d_{est} , q_{dot_est} and d_{dot_est} signals from function block 143 will be equivalent to signals in

30 rotating, elliptical QD reference frame. As reflected in Figure 14C the `fc` command is used in function block 143 as is a "theta" variable. The theta variable is defined as $2*\pi*fc*t$, where t is time.

The particular order in which the transformations are performed in Figure 14C is believed to be particularly important in certain implementations of the illustrated

35 controller because it ensures that the appropriate adjustments are made to accurately

5 transform the input XY commands into QD commands corresponding to the appropriate rotating, elliptical reference frame.

Referring back to Figure 14A, the q_est , d_est , q_dot_est and d_dot_est signals from function block 143 are applied to a group of function blocks, globally indicated as 144. The function blocks 144 compare the estimated QD signals, which reflect the
10 position/velocity of the movable member of actuator 40, with the command QD signals, to produce QD error signals. The function blocks 144 may also implement any appropriate control law, such as a multi-input/multi-output PI control law. The QD error signals from function blocks 144 are appropriately summed by matrix summing block
15 matrix 145 to yield force command signals FQ and FD. Exemplary variables for the summing matrix 145 are provided in Figure 14B.

In the embodiment of Figure 14A, the force command signals FQ and FD are low-pass filtered by low-pass filters 146a and 146b. The filtered FQ and FD signals are then transformed to corresponding FX and FY commands by function block 147. A general illustration of sub-function blocks that may be used to implement function block 147 is
20 provided in Figure 14D.

Referring to Figure 14D, the filtered FQ and FD signals are first transformed into corresponding XY force command signals FX_circ and FY_circ . In the illustrated embodiment, the transformation performed by function block 148 is a simple circular QD-XY-transform that does not take into account the elliptical nature of the QD
25 reference frame used by the controller or the delta offset of that reference frame from the stationary XY reference frame.

The Fx_circ and Fy_circ commands from function block 148 are then applied as inputs to function block 149. Function block 149 also receives as an input the $ecc_command$. In general, function block 149 transforms the FX_circ and FY_circ commands into FX
30 and FY commands (FX_elip , FY_elip) that are adjusted to take into account the elliptical nature of the rotating elliptical reference frame used by the illustrated QD controller.

The FX and FY commands from function block 149, however, are not adjusted to reflect the delta offset of the rotating elliptical reference frame used by the QD controller from the stationary XY reference frame. That adjustment is accomplished by function block
35 150 that receives the signals from function block 149 and a signal corresponding the

5 delta variable and, in response to these inputs, generates FX and FY command signals. As with the transformations reflected in Figure 14C, the transformations of Figure 14D should be performed in the particular order described above to ensure appropriate transformation of the signals.

Referring back to Figure 14A, these FX and FY signals from function block 150 are then
10 amplified by gain amplifiers and applied to the force controller to control the forces applied to the movable member of the actuator 40 as described above.

While the various transformation operations described above for: (i) converting XY feedback signals to a rotating, elliptical QD reference frame; (ii) implementing a control law function in the rotating, elliptical QD reference frame to produce QD force
15 commands; and (iii) transforming the force commands in the rotating QD reference frame to XY force commands may seem complicated, they provide several advantages. Specifically, because of the transformations described above, the control variables actually used in function blocks 144 to implement the control law of the system are DC quantities. As such, a multi-input, multi-output PI or other zero steady state error control
20 law can be used. The use of such a control law can result in better system performance that is available from conventional control approaches. This is especially true in orbiting welder applications where the use of the described transforms is novel. In particular, the use of the transforms and control law described above, eliminates the need for an outer radius control loop since the control functions that would be performed by such a loop
25 are handled by the control law implemented by function blocks 144, 145 and 146.

While the invention has been described in connection with the illustrative embodiments discussed above, those skilled in the art will recognize that many variations may be made without departing from the present invention. For example, the novel actuator 40 is described herein primarily in systems utilizing a flux control system. It will
30 be appreciated that the actuator 40 may be excited by a number of different apparatus including, e.g., a conventional inverter that would produce sinusoidal flux in the E-cores of the actuator 40.. While such an application of the novel actuator 40 would potentially not be as elegant or have the same performance as an application where the actuator was excited with the novel flux controller described herein, it would still provide many of the
35 advantages as a result of the uncoupled nature of the E-cores and the phase coils

- 5 associated with those cores. In light of variations of the type described above, it will be understood that the above description is made by way of example and not for the purposes of limitation.

-5

CLAIMS

1. A flux control system comprising:

an electro-magnetic system comprising at least one phase coil and a core, wherein the phase coil is positioned such that the phase coil establishes a magnetic flux within the core when the phase coil is energized;

a flux observer positioned to provide a flux feedback signal corresponding to the flux in the core; and

a flux controller having a first input that receives a flux command signal, a second input that receives the flux feedback signal, and an output coupled to the phase coil, the flux comprising:

a summing junction that receives the flux command signal and the flux feedback signal and provides an error signal that varies with the difference between the flux command signal and the flux feedback signal; and

an energization control circuit that receives at an input the error signal, the energization control circuit: (a) energizing the phase coil to increase the flux in the phase coil when the error signal indicates that the flux command signal is greater than the flux feedback signal by at least a predetermined amount; and (b) energizing the phase coil to decrease the flux in the control system when the error signal indicates that the flux feedback signal is greater than the flux command signal by at least a predetermined amount.

2. The flux control system of claim 1 wherein the phase coil is coupled across a DC bus by first and second switching devices, wherein the phase energization controller provides output signals for controlling the conductivity of the first and second switching devices, such that the phase energization controller: (a) renders both the first and second switching devices conductive to coupled the phase coil across the DC bus when the error signal indicates that the flux command signal is greater than the flux feedback signal by at least a predetermined amount; and (b) renders both the first and second switching devices non-conductive when the error signal indicates that the flux feedback signal is greater than the flux command signal by at least a predetermined amount.

35

- 5 3. The flux control system of claim 2 wherein the energization controller renders only one of the switches conductive when the error signal indicates that the difference between the flux feedback signal and the flux command signal is less than a predetermined value.
4. The flux control system of claim 3 wherein the energization controller is a time
10 hysteretic, return to zero error controller.
5. The flux control system of claim 1 wherein energization controller energizes the phase coil such that there are regular periods during which the phase coil experiences a zero flux condition and wherein the flux observer comprises an open-loop flux observer that is reset to zero during at least one of the known zero flux periods.
- 15 6. The flux control system of claim 5 wherein the open-loop flux observer comprises a clamped integrator that receives as inputs: (i) a voltage signal having a magnitude that corresponds to the magnitude of a current flowing through the phase coil; and (ii) at least one voltage signal corresponding to a voltage applied to the phase coil, wherein the output of the clamped integrator is the flux feedback signal.
- 20 7. The flux control system of claim 6 wherein:
the phase coil is coupled across a DC bus by first and second switching devices, wherein the phase energization controller provides output signals for controlling the conductivity of the first and second switching devices, such that the phase energization controller: (a) renders both the first and second switching devices
25 conductive to coupled the phase coil across the DC bus when the error signal indicates that the flux command signal is greater than the flux feedback signal by at least a predetermined amount and (b) renders both the first and second switching devices non-conductive when the error signal indicates that the flux feedback signal is greater than the flux command signal by at least a predetermined amount;
- 30 the inputs to the clamped integrator include: (i) a positive voltage signal that is switchably coupled to at least one input of the clamped integrator, wherein the positive voltage signal is related in a known manner to the positive value of the DC bus; and (ii) a negative voltage signal that is switchably coupled to at least one input of the clamped integrator, wherein the negative voltage signal is related in a known manner to
35 the negative value of the DC bus; and

- 5 the positive voltage signal is switchably coupled to an input of the
clamped integrator when both the first and second switching devices are rendered
conductive and the negative voltage signal is switchably coupled to an input of the
clamped integrator when both the first and second switching devices are rendered non-
conductive.
- 10 8. An electro-magnetic actuator comprising:
 a stationary outer assembly, the stationary outer assembly defining a bore,
the stationary outer assembly comprising a plurality of substantially identical,
magnetically-uncoupled E-cores, each E-core defining a central arm and two secondary
arms;
15 a plurality of phase coils, where each phase coil encircles the central arm
of an E-core such that, when electrical energy is applied to a given phase coil, a flux will
be established in the corresponding E-core; and
 a movable member positioned within the bore defined by the stationary
assembly.
- 20 9. The actuator of claim 8 wherein the phase coils are electrically uncoupled, such
that the current flowing through any given phase coil is not constrained by the current
flowing through any other phase coil.
10. The actuator of claim 8 wherein at least one E-core comprises a stack of
substantially identical laminations of a paramagnetic material.
- 25 11. A force control system comprising:
 an electromagnetic actuator, the actuator comprising a stationary member
having a core, a movable member, and a phase coil positioned to establish a flux in the
core when the phase coil is energized, wherein the force exerted on the movable member
varies in proportion to the magnitude of the flux;
30 a flux observer that provides a flux feedback signal corresponding to the
flux in the core;
 a flux controller coupled to the phase coil and to the flux observer, the
flux controller receiving as inputs the flux feedback signal and a flux command signal,
the flux controller providing to the phase coil a phase energization signal to energize the
35 phase coil to increase the flux in the phase coil when the flux command signal is greater

5 than the flux feedback signal by at least a predetermined amount and to energize the phase coil to decrease the flux in the control system when the flux feedback signal is greater than the flux command signal by at least a predetermined amount; and

a force-to-flux controller having an output coupled to the flux controller, the force-to-flux controller receiving as an input a desired force command in a given
10 reference frame and providing at the output the flux command signal wherein the force-to-flux controller converts the desired force command to the flux command signal based on the relationship between the forces associated with the movable member and the flux in the core.

12. The force control system of claim 12 wherein the force-to-flux controller converts
15 the desired force command to the flux command signal based on a minimum norm solution of the force-to-flux relationship between the forces associated with the movable member and the flux in the core.

13. The force control system of claim 11 wherein the force-to-flux controller
20 comprises a digital processing device programmed to ensure that, over a given period, the flux commands provided by the force-to-flux controller are zero for a finite time interval.

14. The force control system of claim 11 wherein the stationary member comprises
first, second and third E-cores arranged such that movement of the movable member may be controlled along two degrees of freedom.

25 15. A welding apparatus comprising:

an electromagnetic actuator including a stationary member and a movable member adapted to be coupled to a workpiece to be welded, the actuator including at least one phase coil and a core, wherein the phase coil is positioned to establish a flux in the core when the phase coil is energized, and wherein the presence of flux in the core
30 will tend to exert a force on the movable member, resulting in movement of the movable member;

a force control system having an input that receives a desired force command and an output coupled to the phase coil, the force control system comprising:

a flux observer that provides a flux feedback signal corresponding to the flux in
35 the core;

5 a flux controller coupled to the phase coil and to the flux observer, the flux controller receiving as inputs the flux feedback signal and a flux command signal, the flux controller providing to the phase coil a phase energization signal to energize the phase coil to increase the flux in the phase coil when the flux command signal is greater than the flux feedback signal and to energize the phase coil to decrease the flux in the control system when the flux feedback signal is greater than the flux command signal;
10 and

a force-to-flux controller having an output coupled to the flux controller, the force-to-flux controller receiving as an input a desired force command in a given reference frame and providing at the output the flux command signal wherein the force-to-flux controller converts the desired force command to the flux command signal based
15 on the relationship between the forces associated with the movable member and the flux in the core;

a position observer that provides at an output a position feedback signal corresponding to the instantaneous position of the movable member; and

20 a position controller having a first input coupled to the output of the position observer and an output coupled to the input of the force controller, the position controller receiving as a second input a position command signal corresponding to the desired position of the movable member, wherein the position controller compares the position command signal with the position feedback signal and generates at its output a force command signal, wherein application of the force corresponding to the force
25 command signal will tend to bring the movable member to the position corresponding to the position command signal.

16. The welding apparatus of claim 15 wherein: (i) the stationary assembly of the electromagnetic actuator defines a bore; (ii) the stationary assembly comprises a plurality
30 of substantially identical, magnetically-uncoupled E-cores, each E-core defining a central arm and two secondary arms; and (iii) the stationary assembly includes a plurality of phase coils, where each phase coil encircles the central arm of an E-core such that, when electrical energy is applied to a given phase coil, a flux will be established in the corresponding E-core; and

5 wherein the movable member positioned within the bore defined by the stationary assembly.

17. An electromagnetic drive for producing controlled motion within a plane, comprising:

10 a stationary assembly having three or more flux generators that are electromagnetically uncoupled from one another positioned substantially equidistantly from one another around said stationary assembly, said stationary assembly having an inner opening therein;

15 a movable member of suitable magnetic material movable relative to said stationary assembly within said inner opening, said movable member being electromagnetically driven by magnetic flux generated by said flux generators in a desired path of motion planar relative to, and within the confines of, said inner opening;

 a power supply for each of said flux generators;

 one or more sensors for generating a signal corresponding to the relative position and motion of said movable member relative to said stationary member; and

20 a controller for said power supplies for said flux generators, said controller receiving said position and motion signals from said one or more sensors for determining the position of said movable member within the inner opening relative to a desired position of said movable member along said desired path of motion and for controlling the output of said power supplies so as to effect movement of said movable member
25 along its said desired path of motion.

18. An electromagnetic drive as set forth in claim 17 wherein each of said flux generators comprises a coil surrounding a core of magnetic material with the end of said core being spaced from said stationary assembly by an air gap.

19. An electromagnetic drive as set forth in claim 17 having an air gap between each
30 of said flux generators and said stationary assembly.

20. An electromagnetic drive as set forth in claim 17 wherein said one or more sensors comprises two accelerometers responsive to movement of said movable member.

21. An electromagnetic drive as set forth in claim 17 wherein said movable member
35 is triangular in shape having a face in proximity to a respective one of said flux

5 generators with each said face of said movable member being separated from its respective flux generator by an air gap.

22. An electromagnetic drive comprising a stationary assembly and an movable member electromagnetically driven by said stationary assembly in a desired pattern of repetitive motion, said stationary assembly having three or more electromagnetic flux
10 generators electromagnetically uncoupled from one another, a power supply for each of said flux generators, a sensor for generating a signal corresponding to the position of said movable member, and a controller for each of said power supplies for said flux generators, said controller receiving said position signal from said sensor for determining the position of said movable member relative to a desired position of said movable
15 member along said desired pattern of repetitive motion and for controlling the output of said power supply associated with each of said flux generators so as to effect movement of said stationary assembly along its said desired pattern of repetitive motion.

23. An electromagnetic drive as set forth in claim 22 wherein each of said flux generators comprises a coil surrounding a core of magnetic material with the end of said
20 core being spaced from said movable member by an air gap.

24. An electromagnetic drive as set forth in claim 22 having an air gap between each of said flux generators and said movable member.

25. Apparatus for friction welding thermoplastic parts along an interface between said parts, said apparatus comprising a holder for a first part, a holder for a second part
25 with said parts in forced engagement with one another along said interface between the parts to be welded, and a drive for driving said second holder and said second part along a predetermined repetitive path relative to said first part while said parts are in forced engagement with one another so as to frictionally heat said parts along said interface such that upon terminating said repetitive motion, said parts are welded to one another, said
30 drive comprising a stationary assembly and a movable member electromagnetically driven by said stationary assembly in said predetermined repetitive path, said stationary assembly having three or more electromagnetic flux generators electromagnetically uncoupled from one another, a power supply for each of said flux generators, a sensor for generating a signal corresponding to the position of said movable member, and a
35 controller for each of said power supplies for said flux generators, said controller

- 5 receiving said position signal from said sensor for determining the position of said
movable member relative to a desired position of said movable member along said
desired pattern of repetitive motion and for controlling the output of said power supply
associated with each of said flux generators so as to effect movement of said stationary
assembly along its said desired pattern of repetitive motion.
- 10 26. An apparatus for friction welding thermoplastic parts along an interface between
said parts, said apparatus comprising a holder for a first part, a holder for a second part
with said parts in forced engagement with one another along said interface between the
parts to be welded, and a drive for driving said second holder and said second part along
a predetermined repetitive path relative to said first part while said parts are in forced
15 engagement with one another so as to frictionally heat said parts along said interface such
that upon terminating said repetitive motion, said parts are welded to one another, said
drive comprising a stationary assembly and a movable member electromagnetically
driven by said stationary assembly in said predetermined repetitive path, said stationary
assembly having three or more electromagnetic flux generators electromagnetically
20 uncoupled from one another, a power supply for each of said flux generators, a sensor for
generating a signal corresponding to the position of said movable member, and a
controller for each of said power supplies for said flux generators, said controller
receiving said position signal from said sensor for determining the position of said
movable member relative to a desired position of said movable member along said
25 desired pattern of repetitive motion and for controlling the output of said power supply
associated with each of said flux generators so as to effect movement of said stationary
assembly along its said desired pattern of repetitive motion.
27. A flux observer that is a low pass filtering of $V-iR$ for a bi-polar zero mean flux
fed system.

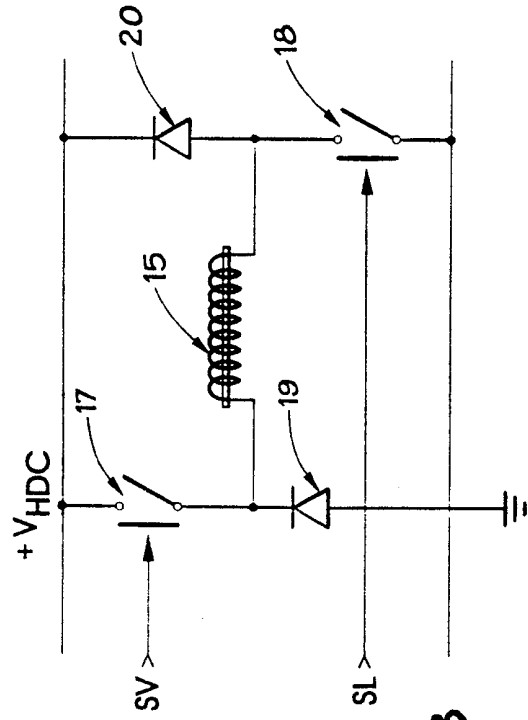
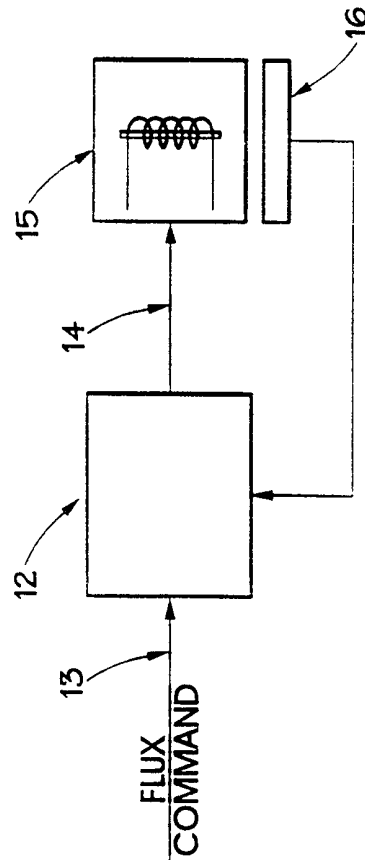
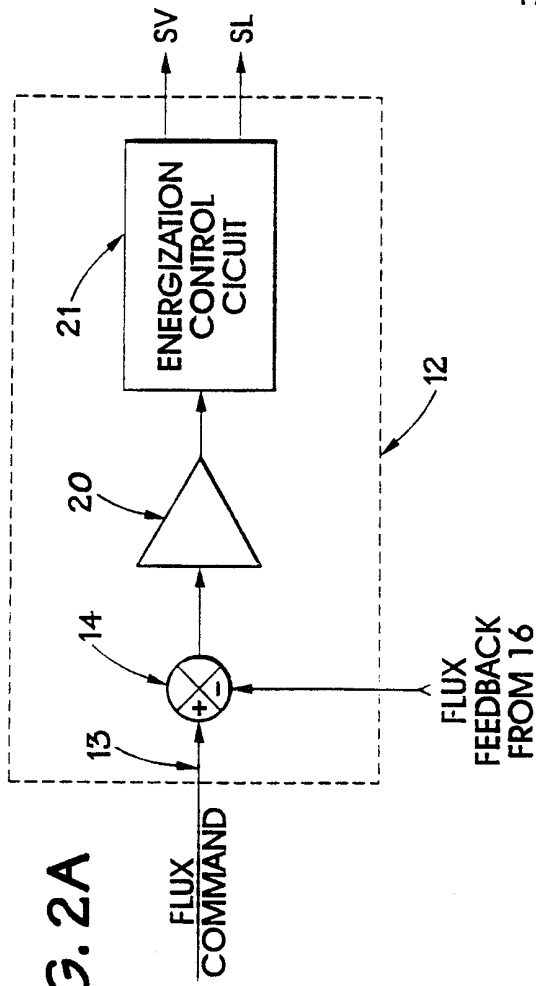

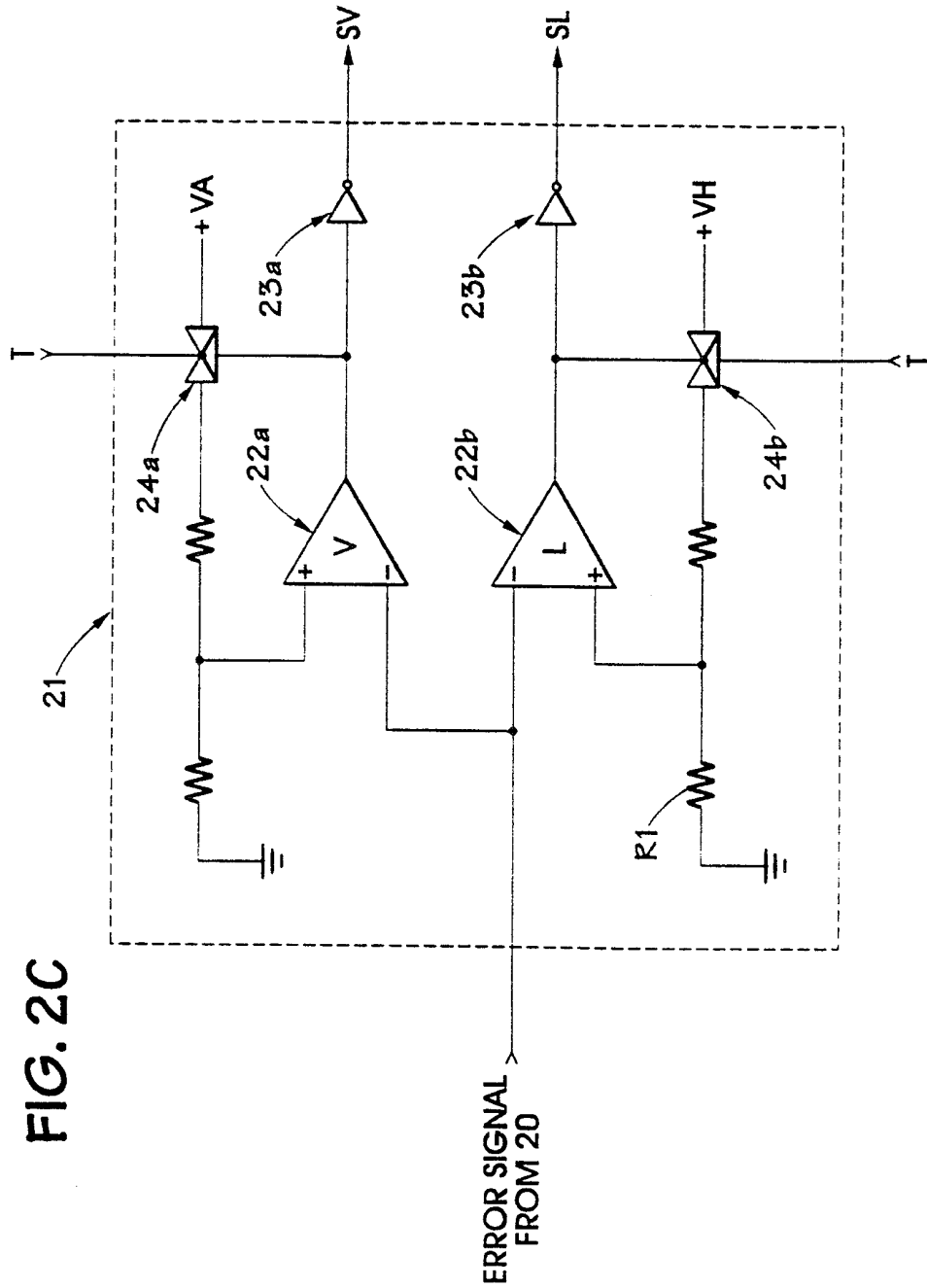

FIG. 2C

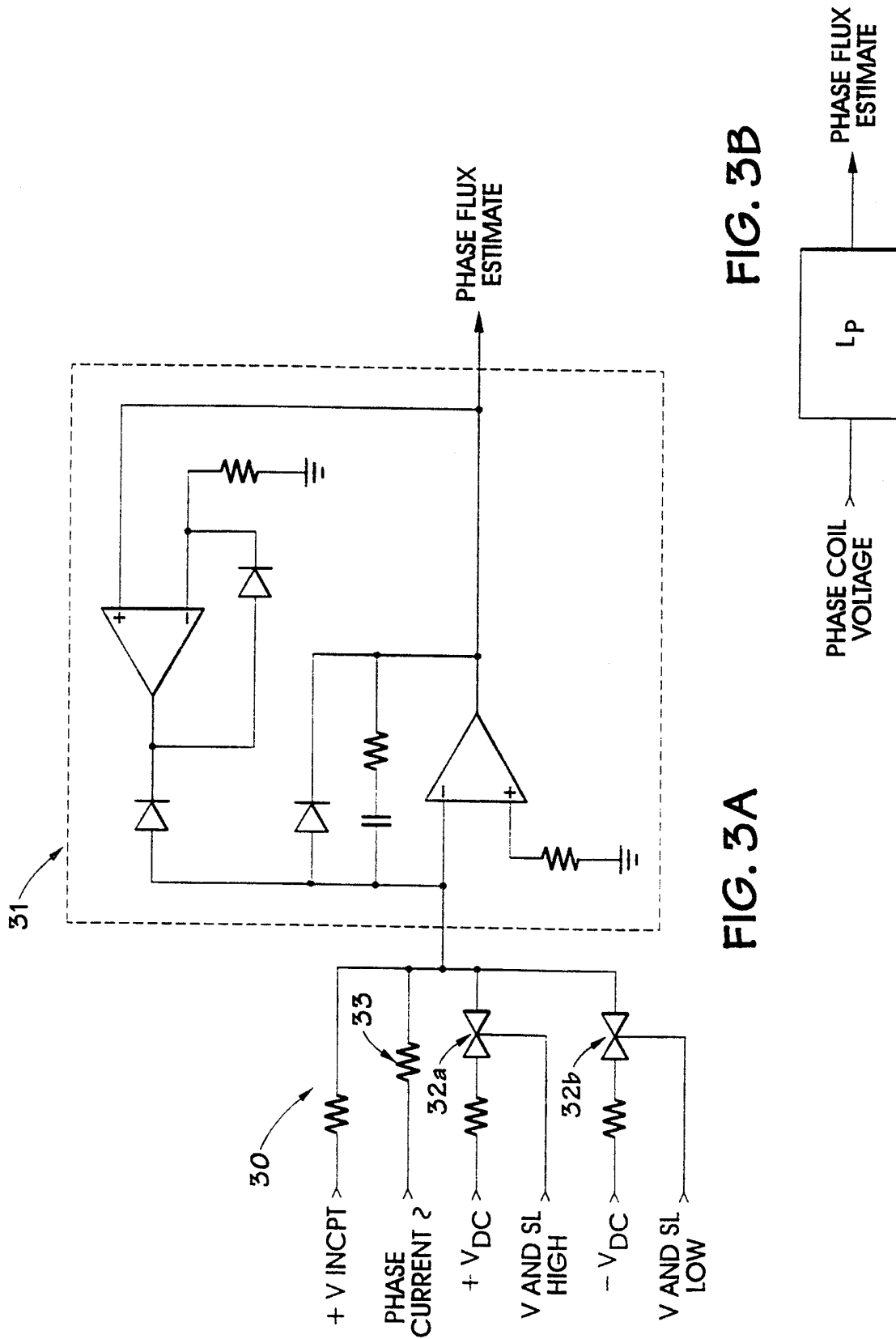

FIG. 3A

FIG. 3B

FIG. 7A

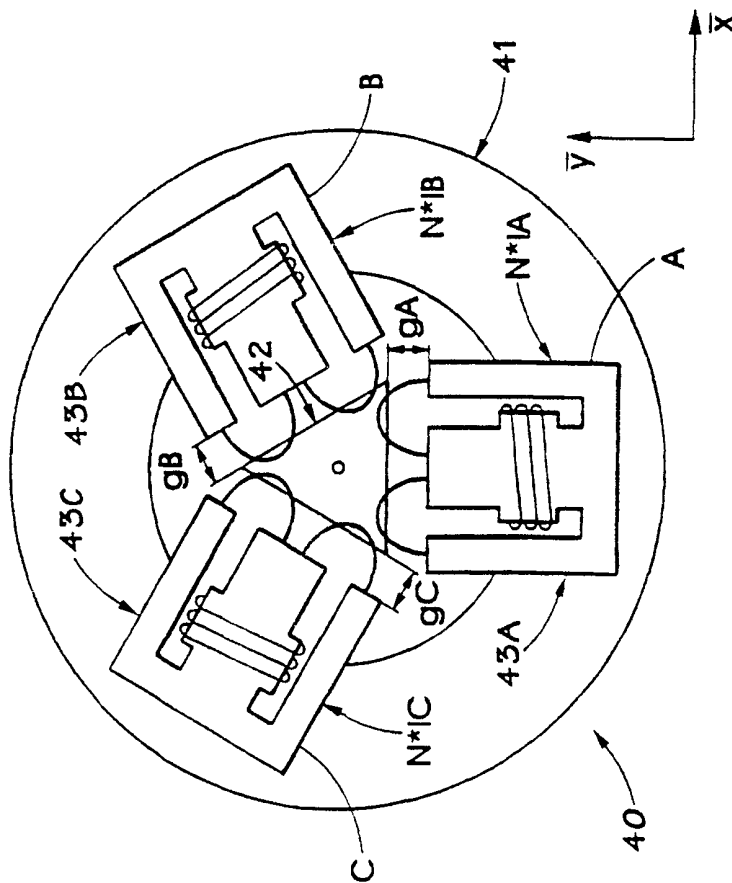
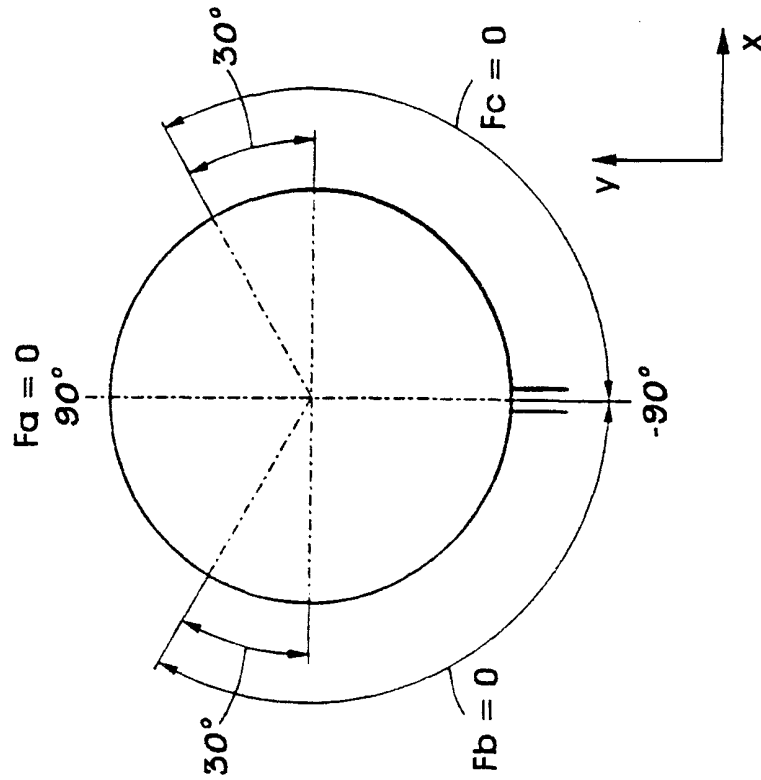

FIG. 4

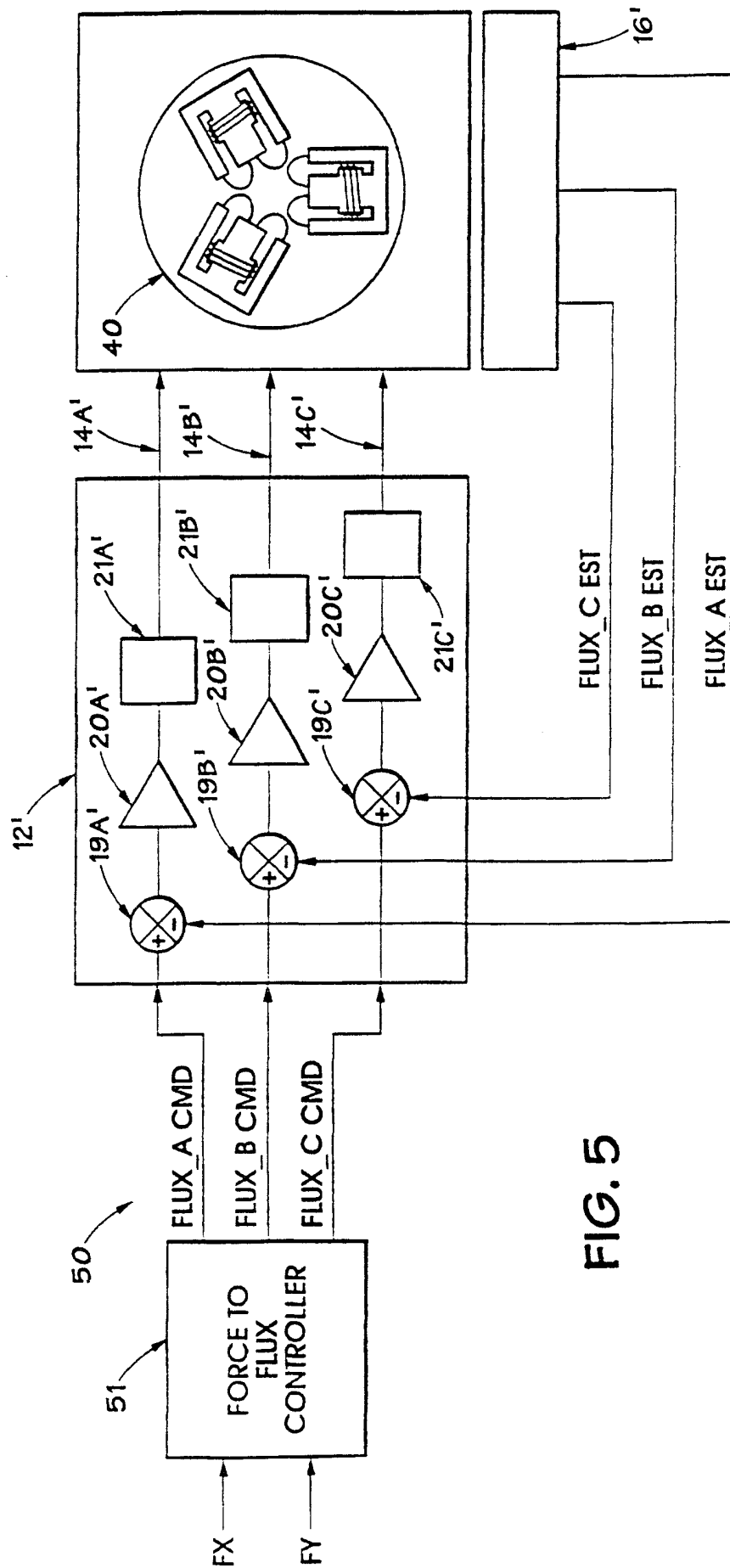

FIG. 5

DISCRETE SUPER BLOCK	SAMPLING INTERVAL	FIRST SAMPLE	EXT. INPUTS	EXT. OUTPUTS	ENABLE
FLUX_REF	0.00022	0.	2	6	PARENT

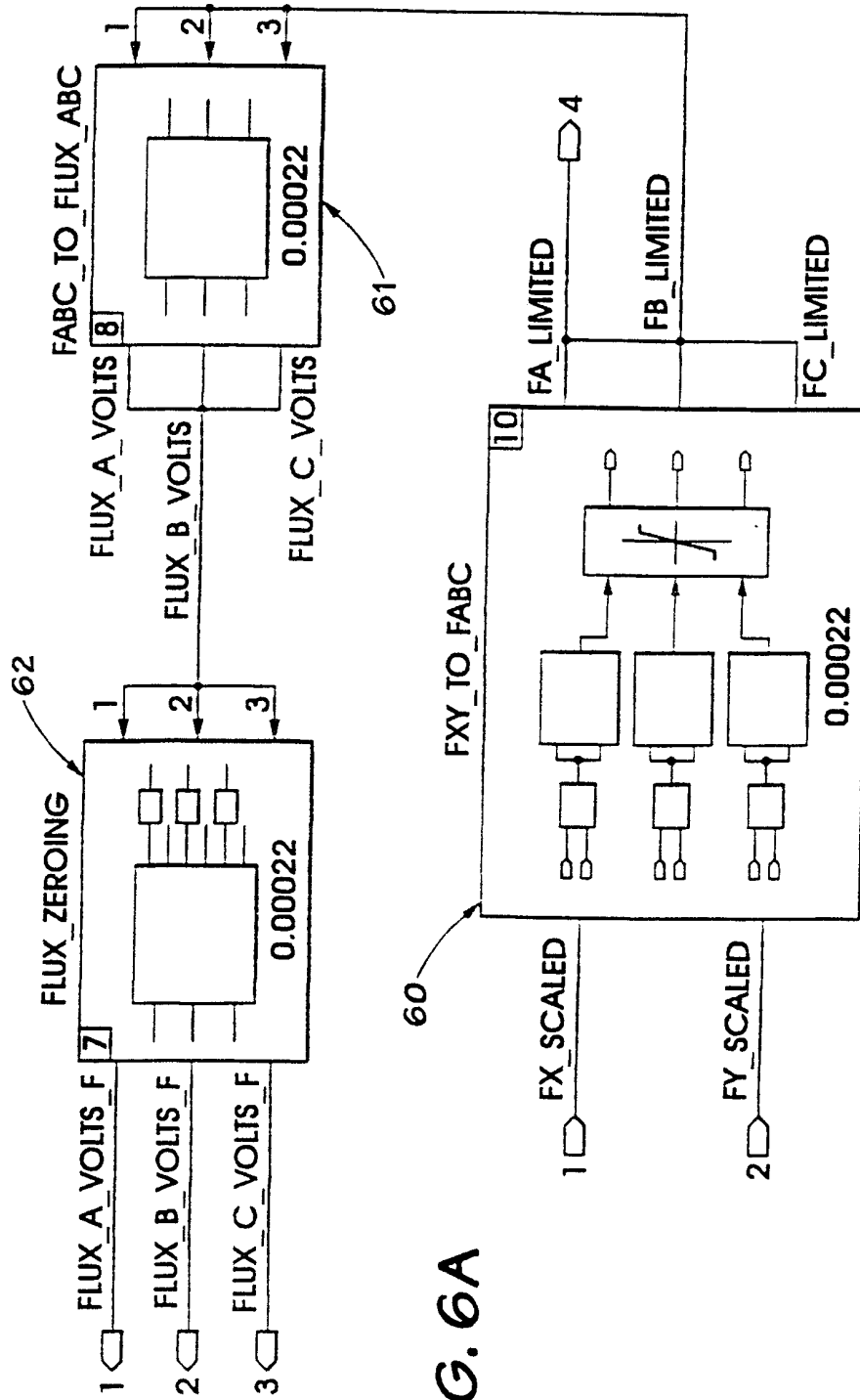
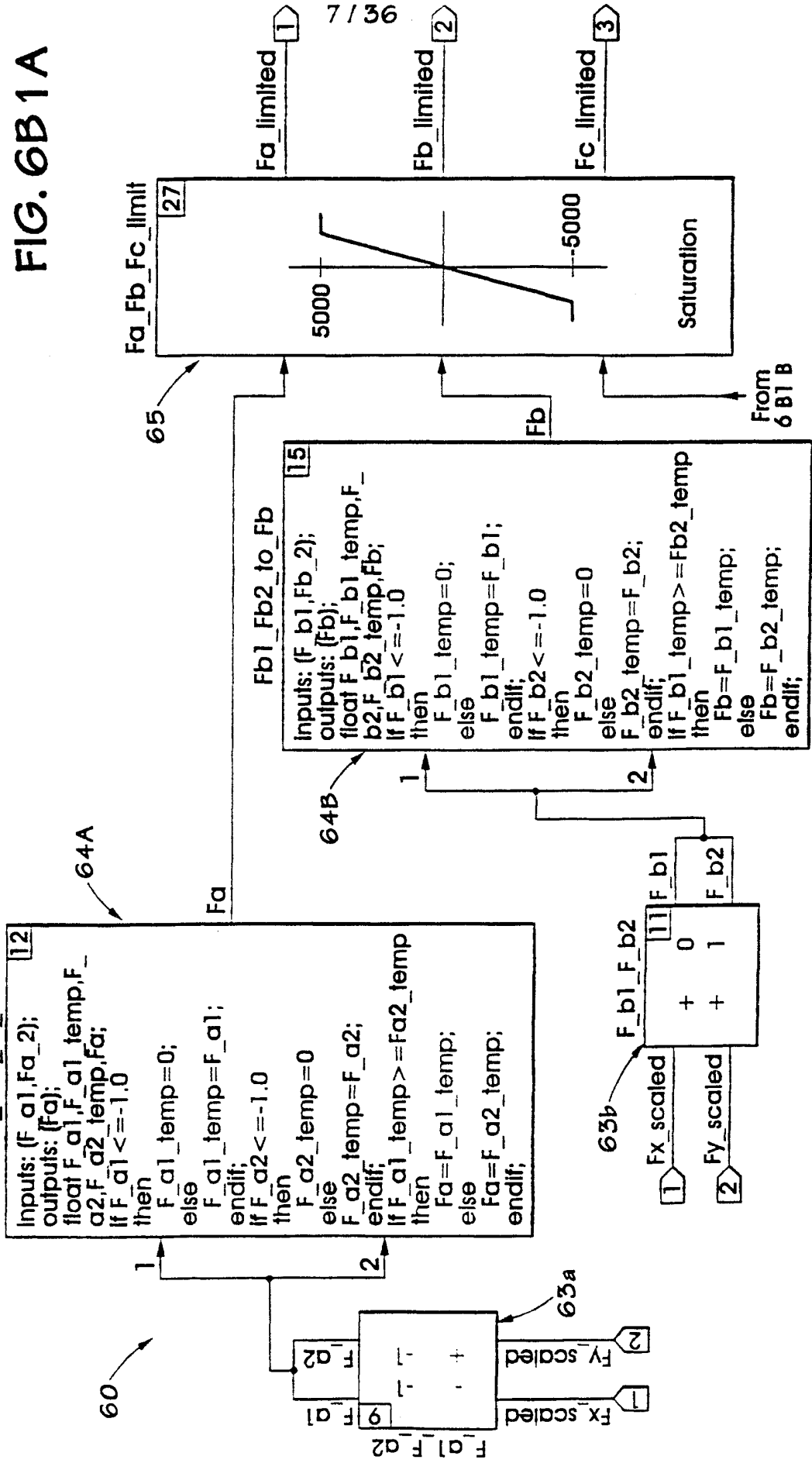

FIG. 6A

DISCRETE SUPER BLOCK	SAMPLING INTERVAL	FIRST SAMPLE	EXT. INPUTS	EXT. OUTPUTS	ENABLE PARENT
FXY_TO_FABC	0.00022	0.	2	3	

FIG. 6B1A



DISCRETE SUPER BLOCK FX TO FABC	SAMPLING INTERVAL 0.00022	FIRST SAMPLE 0.	EXT. INPUTS 2	EXT. OUTPUTS 3	ENABLE PARENT
------------------------------------	------------------------------	--------------------	------------------	-------------------	------------------

FIG. 6B1B

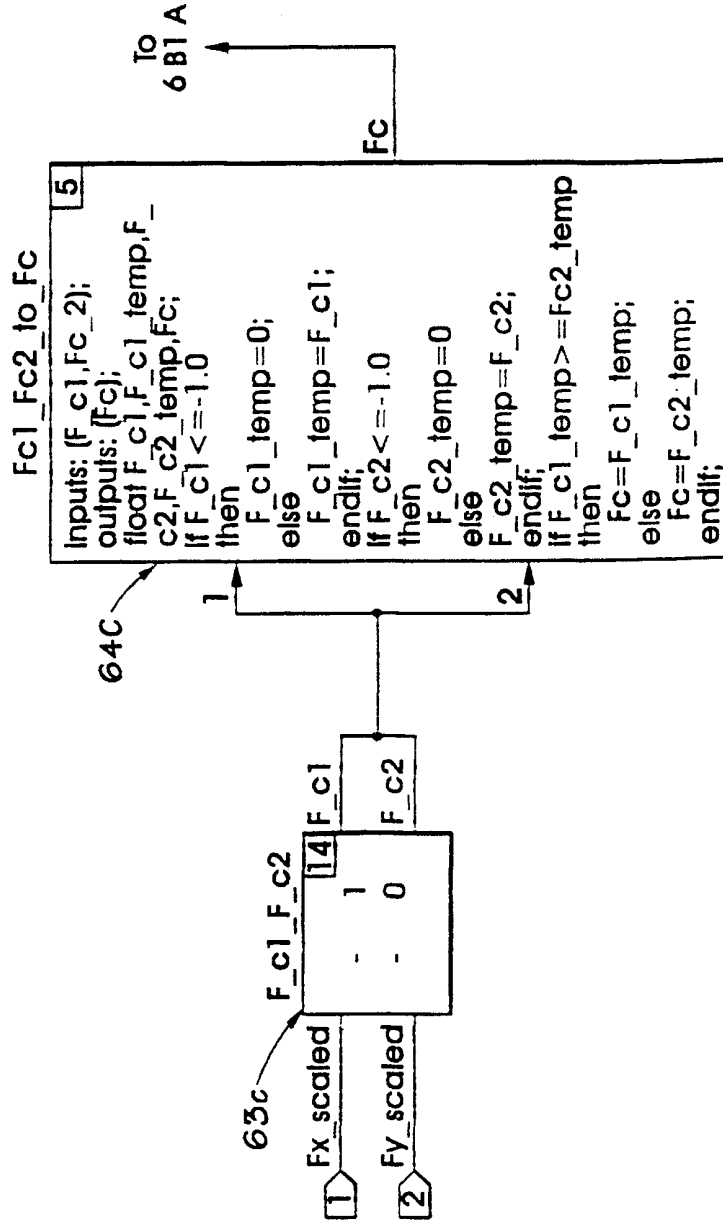

TYPE = STATE - SPACE SYSTEM		ID = 9
<input type="checkbox"/> BLOCK NAME	INPUTS	STATES
F_a1 F_a2 <input checked="" type="checkbox"/>	2	0
2 - BY - 2 STATE SPACE MATRIX		
-0.577	-1.	
0.577	-1.	
ZERO INITIAL CONDITIONS : YES		
INPUT EXTERNAL SIGNALS		OUTPUT LABELS
1 "Fx_SCALED"	1 "F_a1"	
2 "Fy_SCALED"	2 "F_a2"	
COMMENTS		
<input type="checkbox"/> VIEW_INPUT	COLOR	IN_PINS
<input type="checkbox"/> EXTERNAL_SIGNALS	0	SHOW_ALL
	ALT. SPEC	SHOW_ALL
		ON
<input type="button" value="CANCEL"/>		<input type="button" value="DONE"/>

FIG. 6B 2

TYPE = STATE - SPACE SYSTEM		ID = 11
BLOCK NAME	INPUTS	STATES
F_b1_F_b2 <input checked="" type="checkbox"/>	2	0
2 - BY - 2 STATE SPACE MATRIX		
1.155	0.	
0.577	1.	
ZERO INITIAL CONDITIONS : YES		
INPUT EXTERNAL SIGNALS		OUTPUT LABELS
1 "Fx_SCALED"	1 "F_b1"	
2 "Fy_SCALED"	2 "F_b2"	
COMMENTS		
<input type="button" value="CANCEL"/>	VIEW INPUT EXTERNAL SIGNALS	COLOR 0
	EXTERNAL SIGNALS	SPECIAL 0
		IN_PINS SHOW_ALL
		OUT_PINS SHOW_ALL
		LABELS ON
		<input type="button" value="DONE"/>

FIG. 6B 3

TYPE = STATE - SPACE SYSTEM		ID = 14
<input type="checkbox"/> BLOCK NAME	INPUTS	OUTPUTS
F_c1_F_c2 <input checked="" type="checkbox"/>	2	2
		STATES
		0
2 - BY - 2 STATE SPACE MATRIX		
-0.577	1.	
-1.155	0.	
ZERO INITIAL CONDITIONS : YES		
INPUT EXTERNAL SIGNALS		OUTPUT LABELS
1 "Fx_SCALED"	1 "F_c1"	
2 "Fy_SCALED"	2 "F_c2"	
COMMENTS		
<input type="checkbox"/> VIEW_INPUT	COLOR	IN_PINS
<input type="checkbox"/> EXTERNAL_SIGNALS	0	SHOW_ALL
	SPECIAL	OUT_PINS
		SHOW_ALL
		LABELS
		ON
<input type="button" value="CANCEL"/>		<input type="button" value="DONE"/>

FIG. 6B 4

DISCRETE SUPER BLOCK FABC_TO_FLUX_ABC	SAMPLING INTERVAL 0.00022	FIRST SAMPLE 0.	EXT. INPUTS 3	EXT. OUTPUTS 3	ENABLE PARENT
--	------------------------------	--------------------	------------------	-------------------	------------------

FLUX_A_B_C

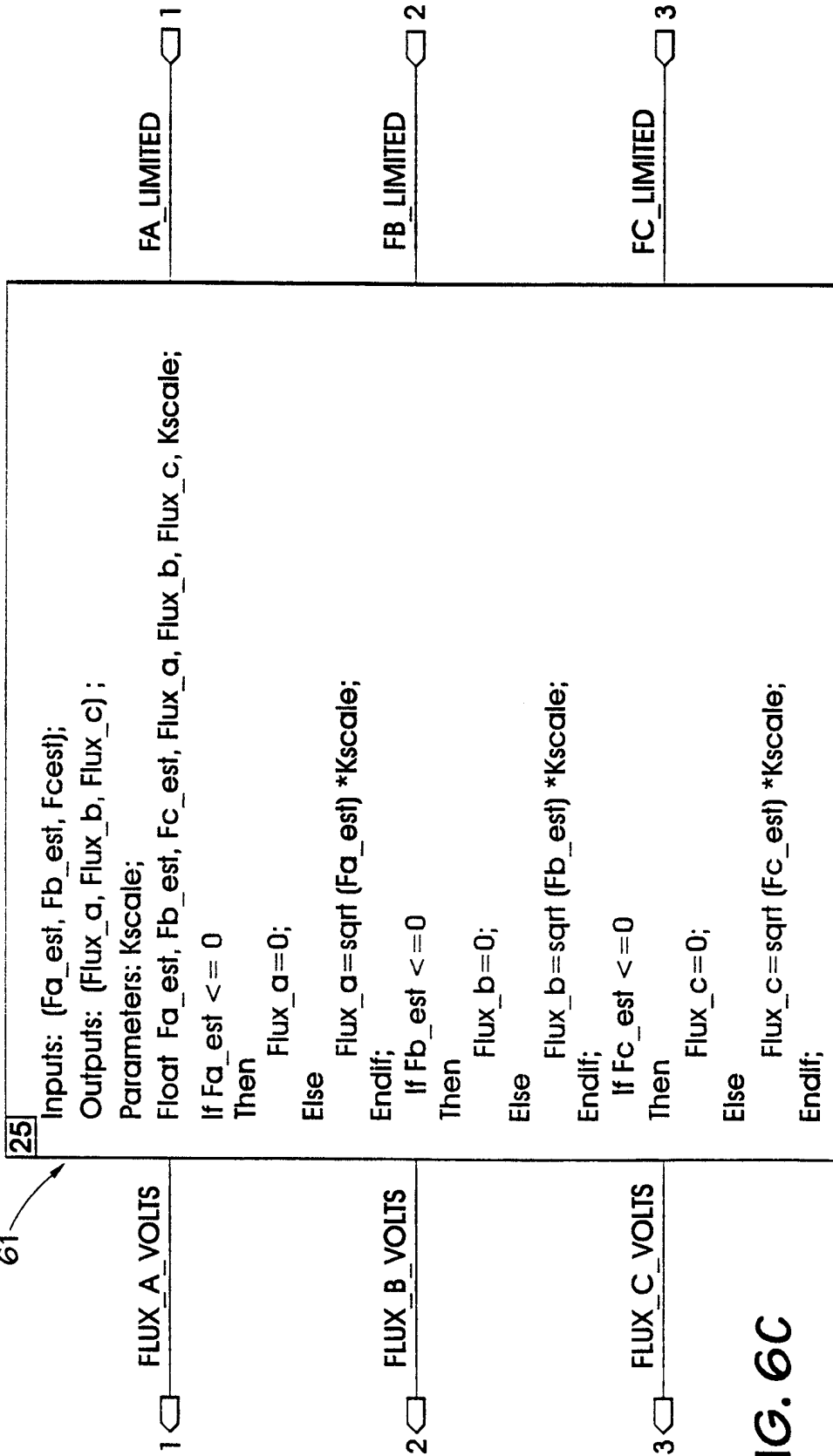

FIG. 6C

FIG. 6D 1

DISCRETE SUPER BLOCK SAMPLING INTERVAL FIRST SAMPLE EXT. INPUTS EXT. OUTPUTS ENABLE PARENT

FLUX_ZEROING 0.00022 0. 3 3

67 ZERO_FLUX 62

```

4 Inputs: (flux_a_volts_avg,flux_a_volts,flux_b_volts_avg,flux_b_volts);
  Inputs: (flux_c_volts_avg,flux_c_volts);
  Outputs: (flux_a_volts_f,flux_b_volts_f,flux_c_volts_f);
  Parameters: (flux_divide,flux_volts_min);
  Float flux_a_volts_avg,flux_a_volts,flux_b_volts_avg,flux_b_volts;
  Float flux_c_volts_avg,flux_c_volts,flux_a_volts_f,flux_b_volts_f;
  Float flux_c_volts_f;
  If flux_a_volts < flux_a_volts_avg/flux_divide
  Then
    Flux_a_volts_f=flux_volts_min;
  Else
    Flux_a_volts_f=flux_a_volts;
  Endif;
  If flux_b_volts < flux_b_volts_avg/flux_divide
  Then
    Flux_b_volts_f=flux_volts_min;
  Else
    Flux_b_volts_f=flux_b_volts;
  Endif;
  If flux_c_volts < flux_c_volts_avg/flux_divide
  Then
    Flux_c_volts_f=flux_volts_min;
  Else
    Flux_c_volts_f=flux_c_volts;
  Endif;
  
```

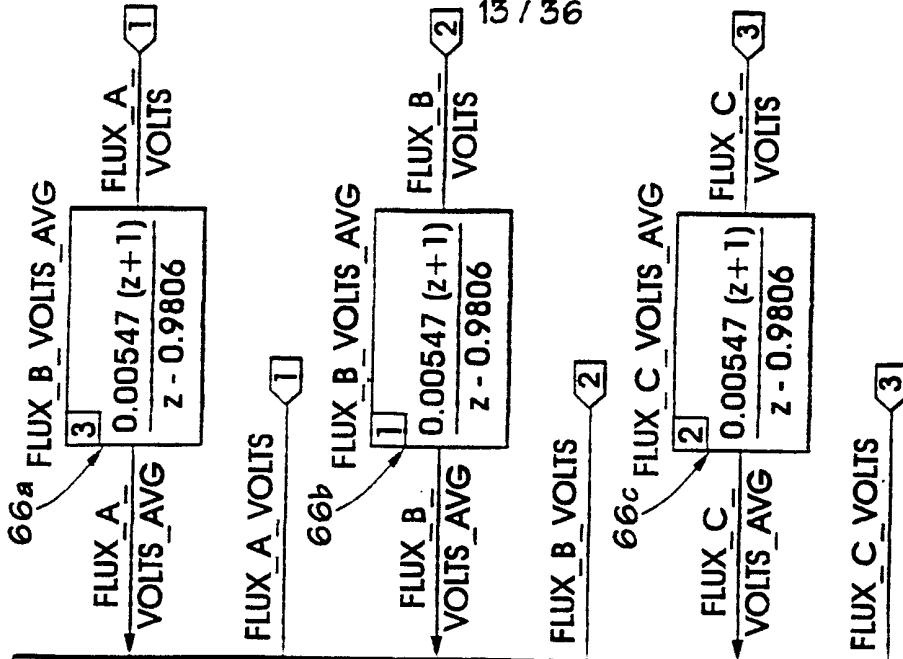

1 FLUX A VOLTS F

2 FLUX B VOLTS F

3 FLUX C VOLTS F

FIG. 6D 2

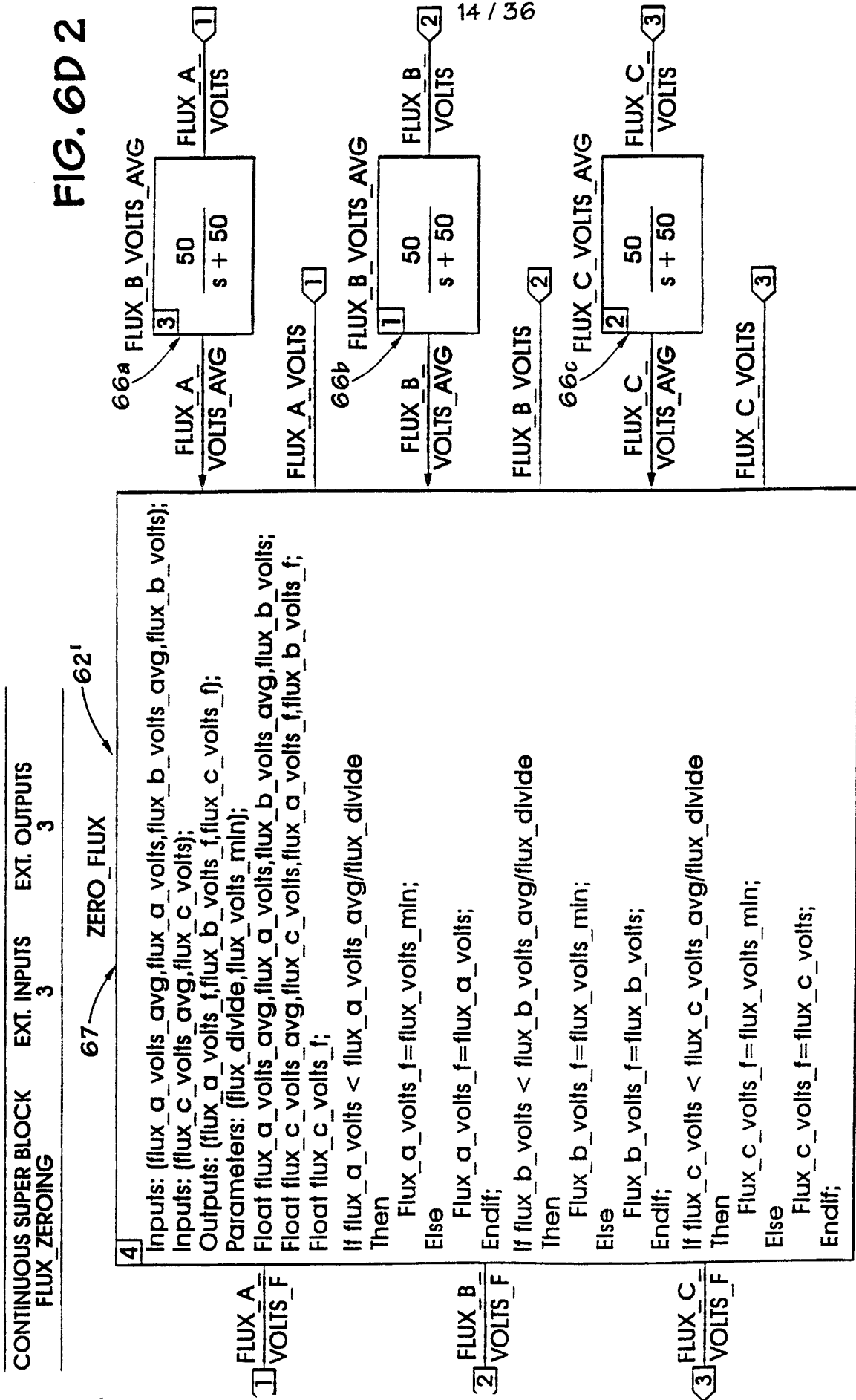

15 / 36

```

Inputs: (Fx, Fy);
Outputs: (Fa, Fb, Fc, angle);
Parameters: pi;
Float Fx, Fy, Fa, Fb, Fc, angle, pi;

If Fx == 0
Then
    If Fy == 0
    Then
        Angle = 0;
    Else
        Angle = atan 2 (Fy, Fx) *180/pi;
    Endif;
Else
    Angle = btan 2 (Fy, Fx) *180/pi;
Endif;
If angle > = -90
Then
    If angle > 30
    Then
        Fc = 0;
        Fb = (2/(sqrt(3.0)))*Fx;
        Fa = Fy+Fb/2;
    Endif;
Endif;
If angle > = 30
Then
    If angle > 150
    Then
        Fb = 0;
        Fc = (1/sqrt(3.0))*Fx+Fy;
        Fa = 2*Fy Fb;
    Endif;
Endif;
If angle > = 150
Then
    Fb = 0;
    Fc = (-2/(sqrt(3.0)))*Fx;
    Fa = Fy+ Fc/2;
Endif;
If angle < -90
Then
    Fb = 0;
    Fc = (-2/sqrt(3.0))*Fx;
    Fa = Fy+ Fc/2;
Endif;

```

FIG. 7B

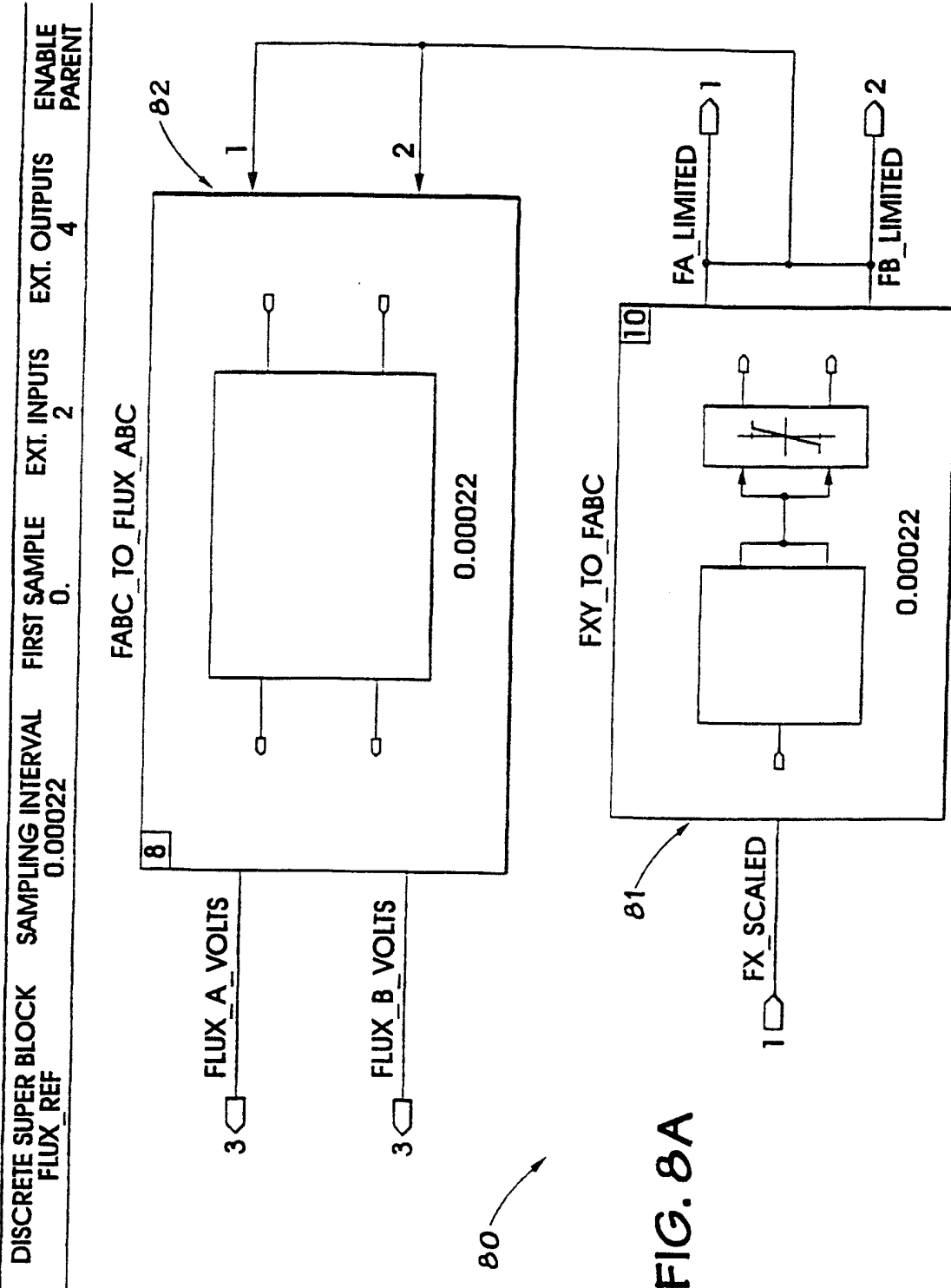
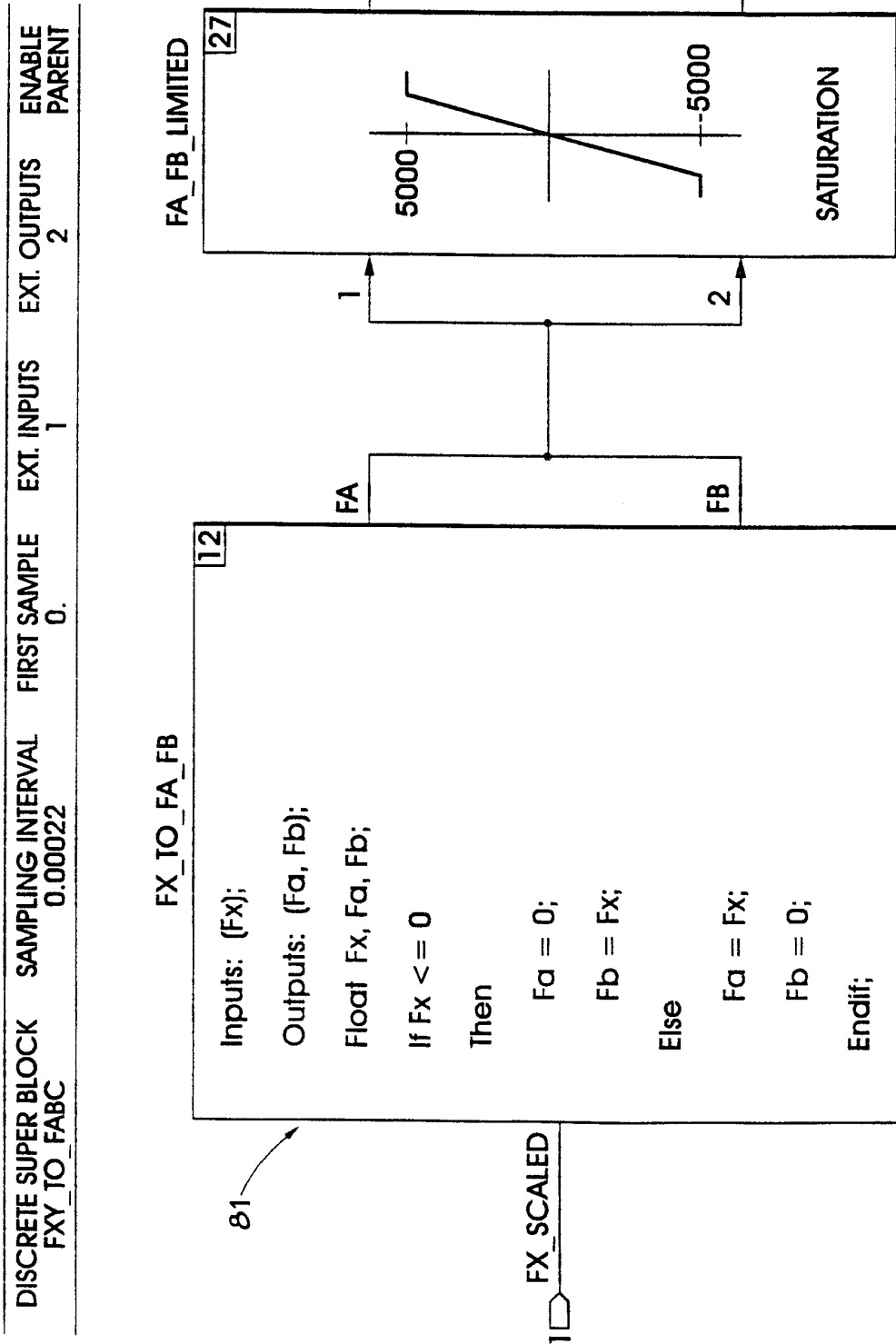

FIG. 8B



DISCRETE SUPER BLOCK FABC_TO_FLUX_ABC	SAMPLING INTERVAL 0.00022	FIRST SAMPLE 0.	EXT. INPUTS 2	EXT. OUTPUTS 2	ENABLE PARENT
--	------------------------------	--------------------	------------------	-------------------	------------------

FLUX_A_B_C

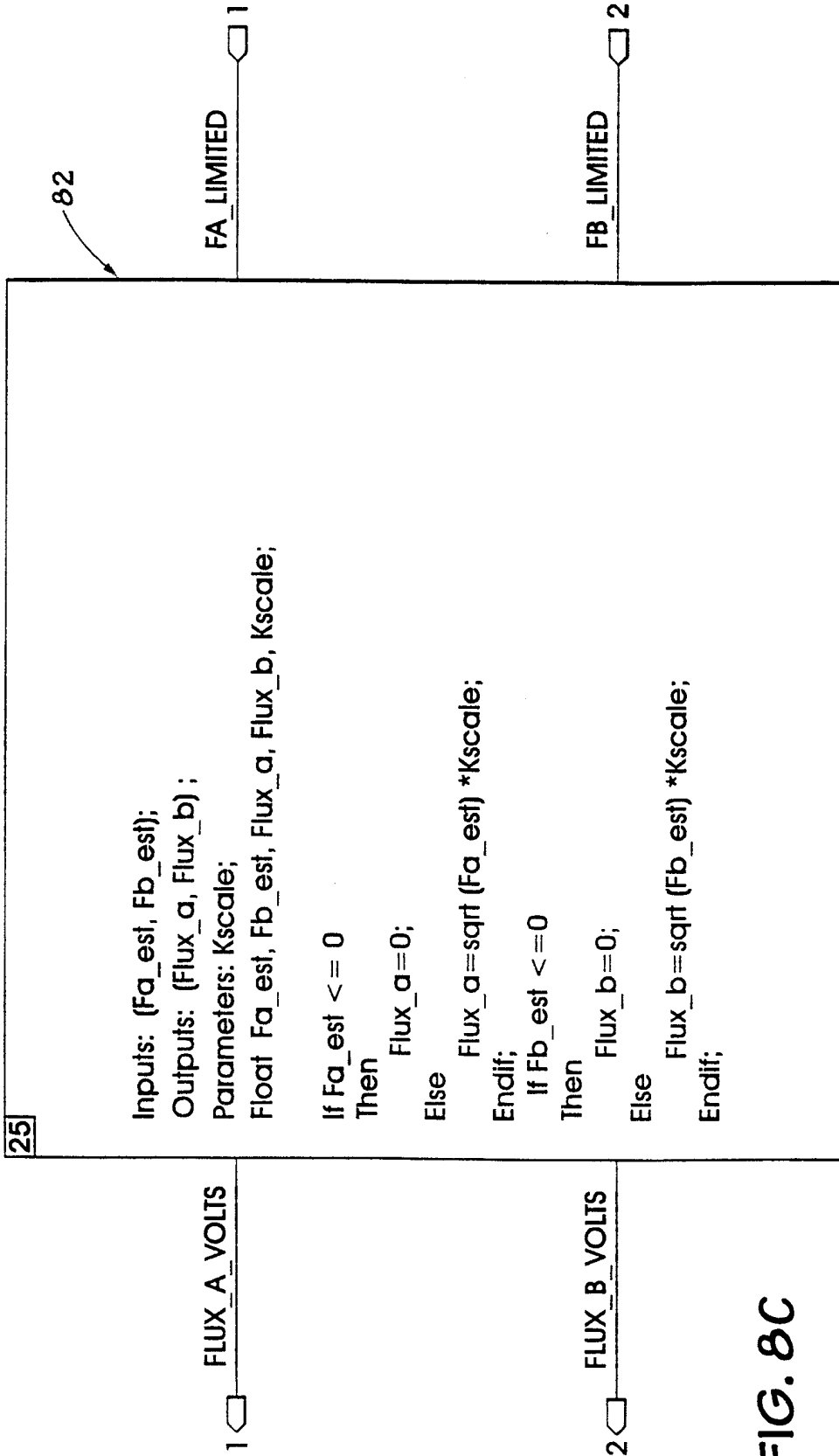

FIG. 8C

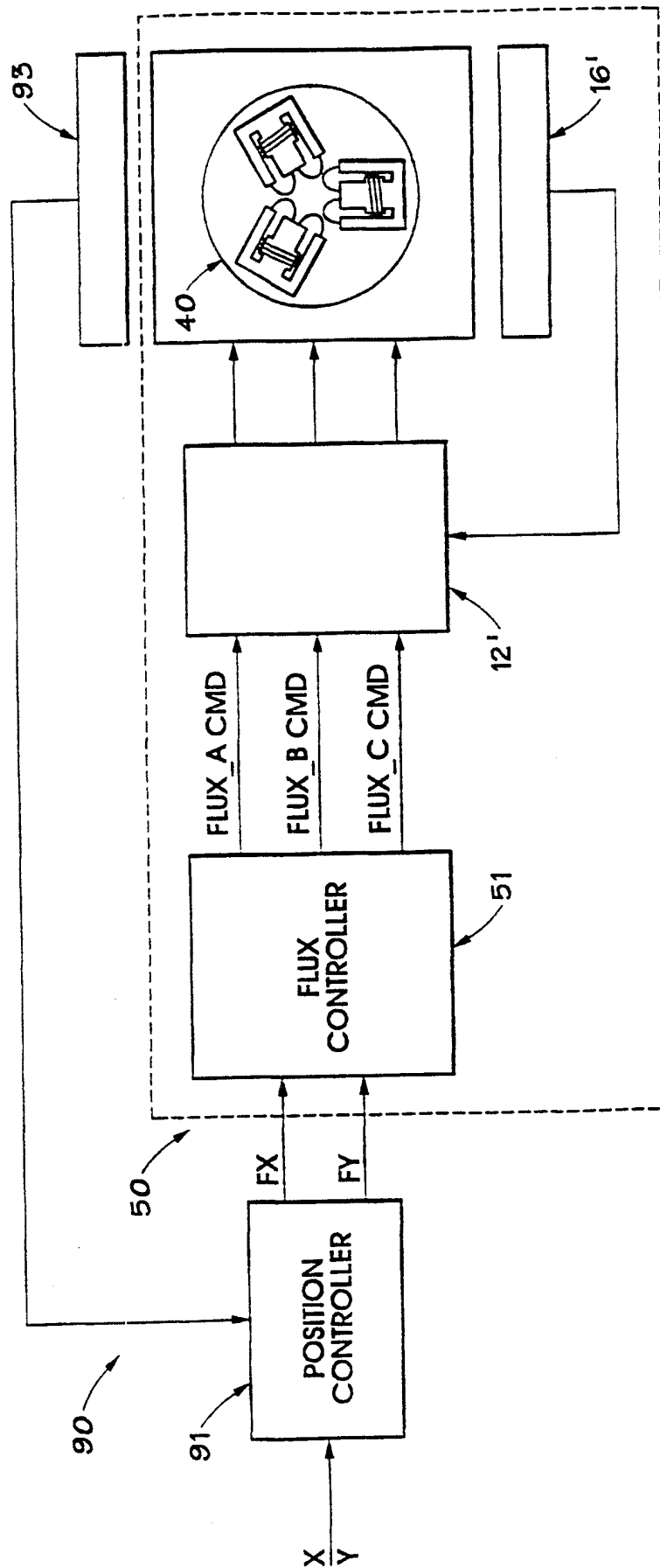

FIG. 9

FIG. 10A

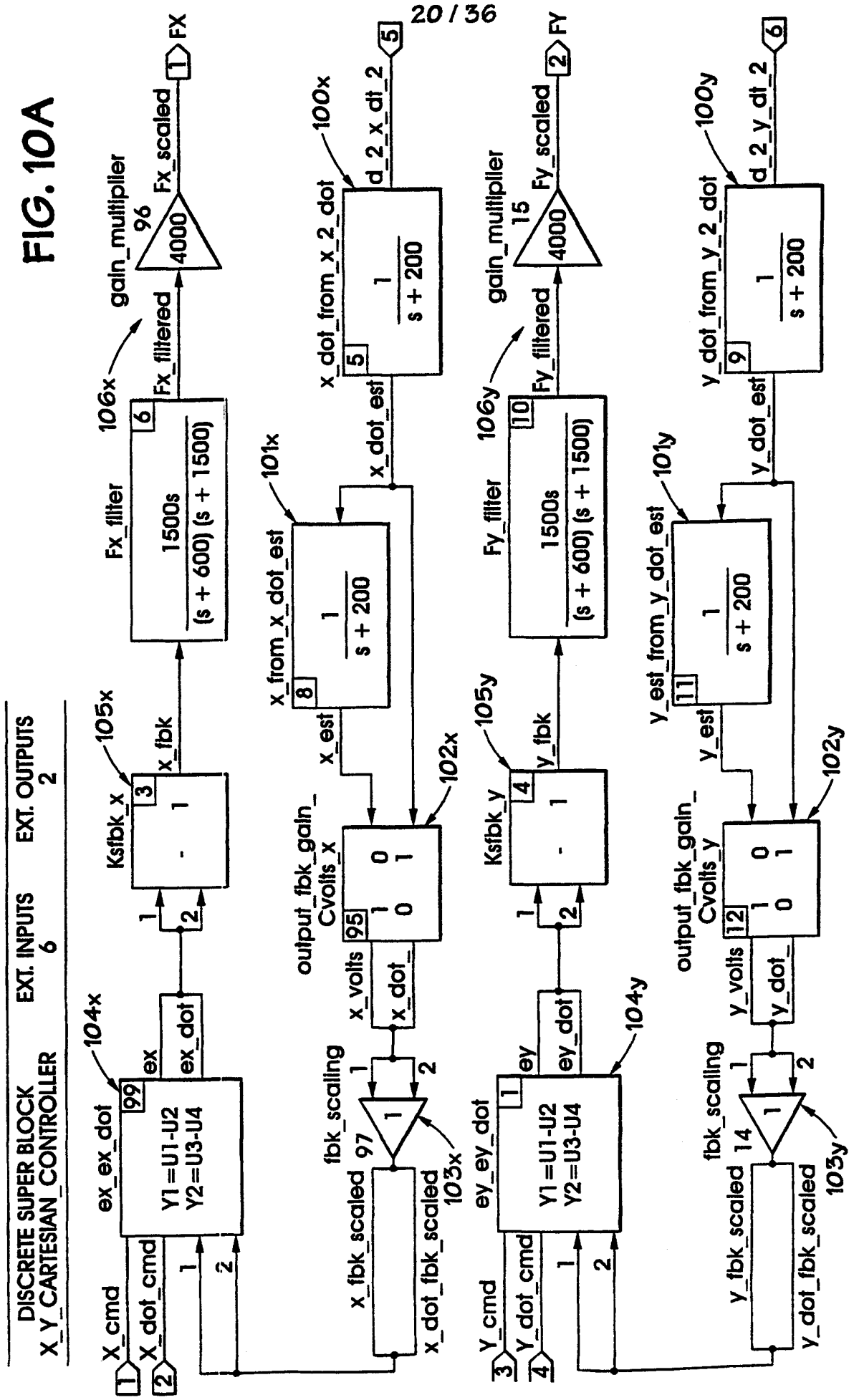
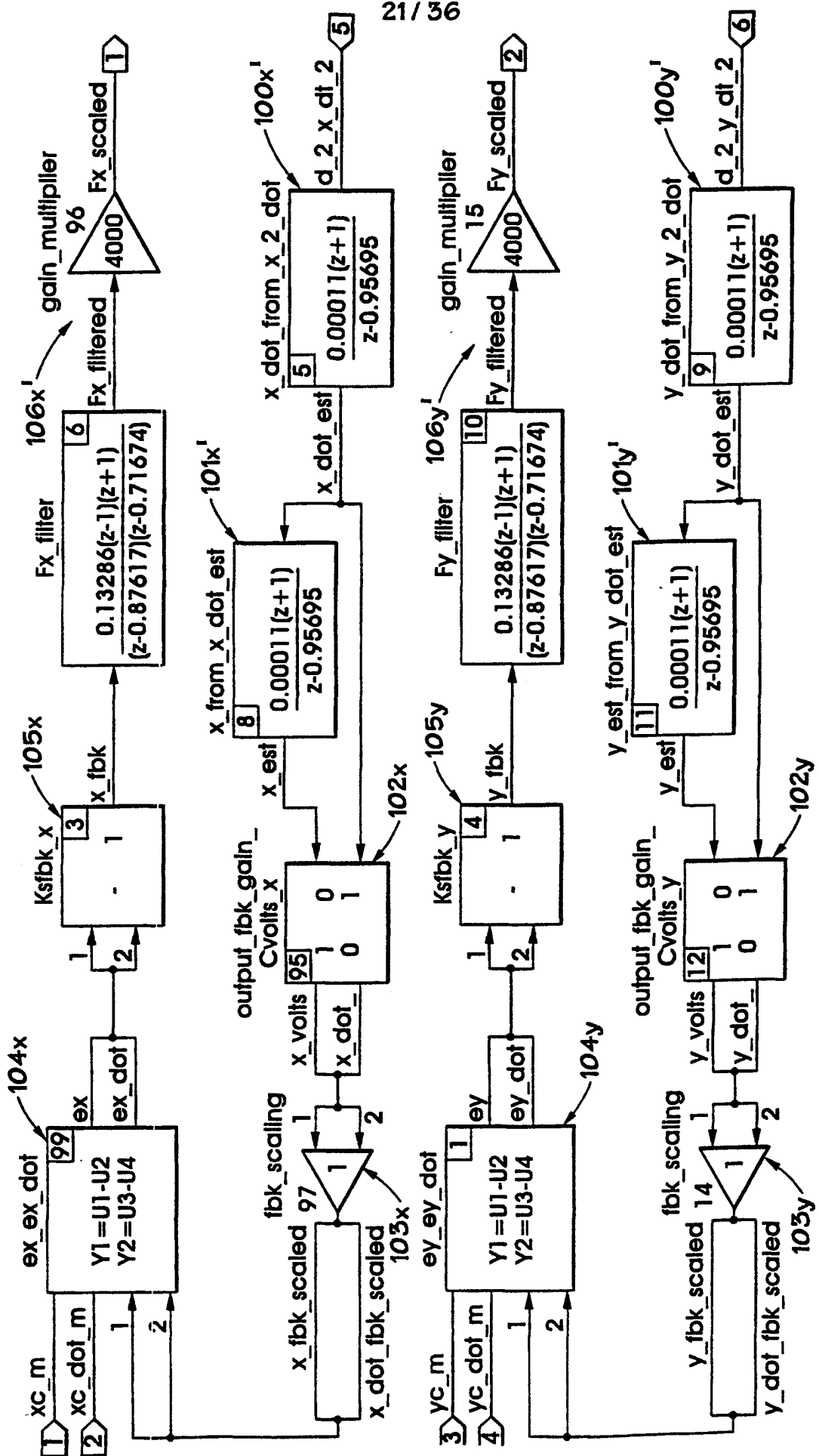

FIG. 10B

DISCRETE SUPER BLOCK	SAMPLING INTERVAL	FIRST SAMPLE	EXT. INPUTS	EXT. OUTPUTS	ENABLE
X_Y_CARTESIAN_CONTROLLER	0.00022	0.	6	2	PARENT



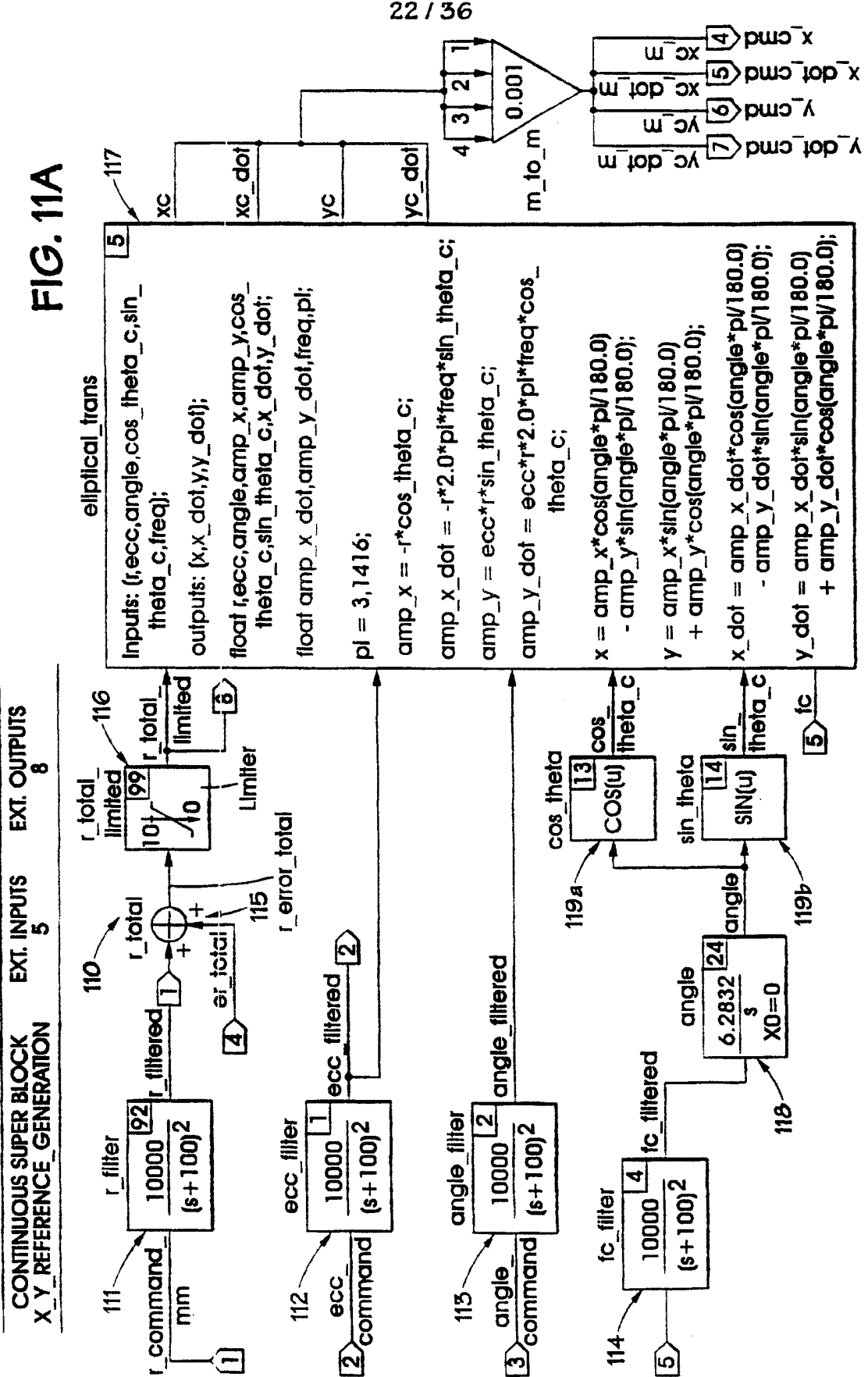
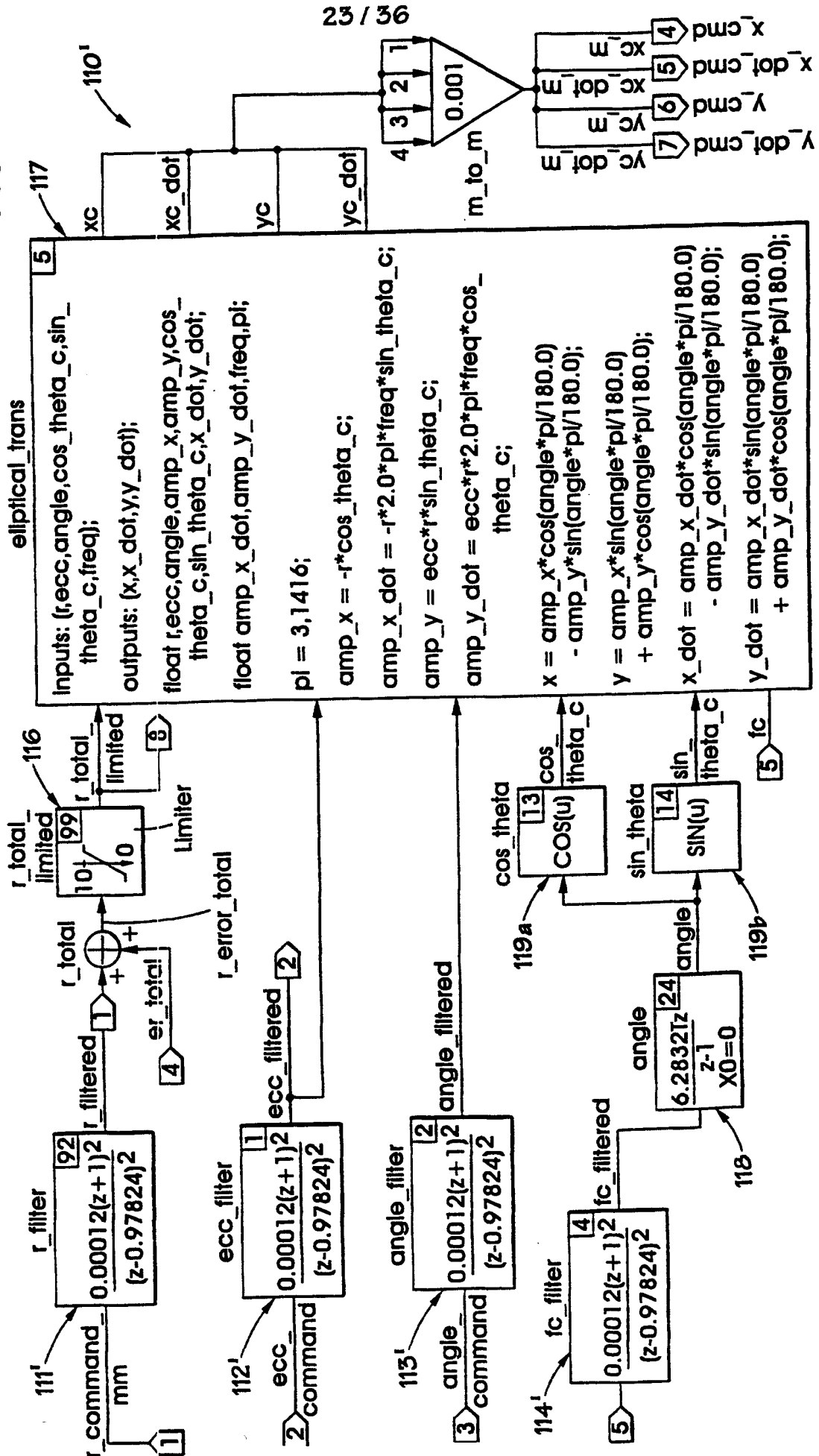

FIG. 11B

CONTINUOUS SUPER BLOCK	SAMPLING INTERVAL	FIRST SAMPLE	EXT. INPUTS	EXT. OUTPUTS	ENABLE PARENT
X_Y_REFERENCE_GENERATION	0.00022	0.	5	8	



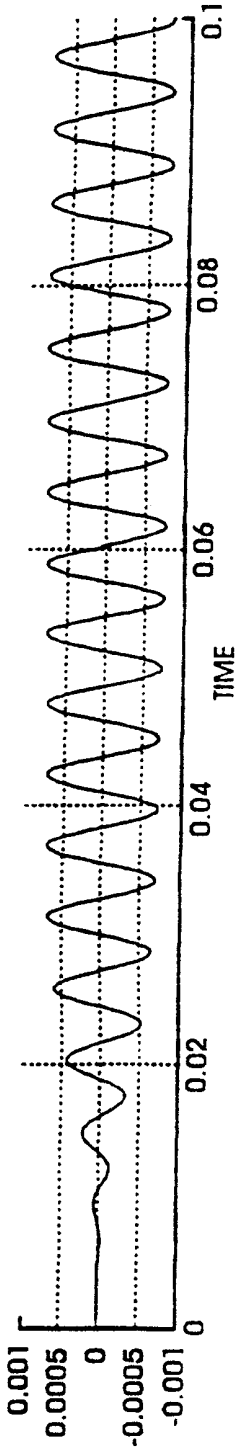

FIG. 12A 1

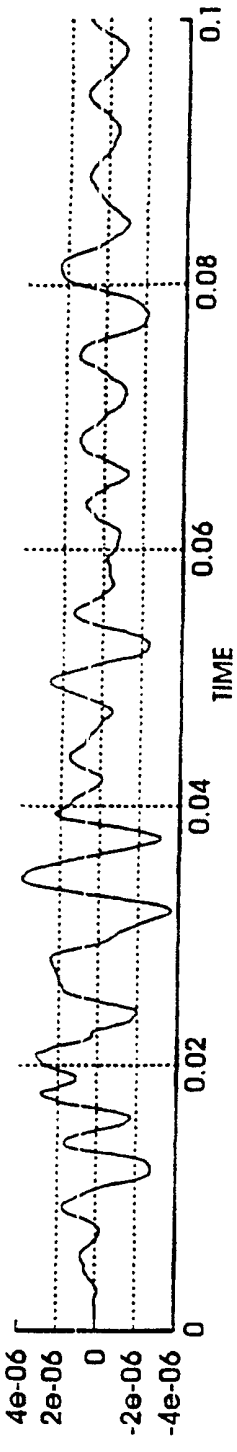

FIG. 12A 2

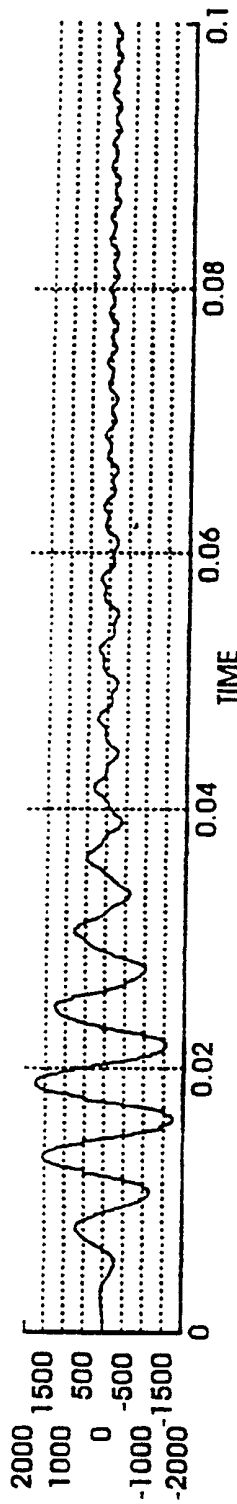

FIG. 12A 3

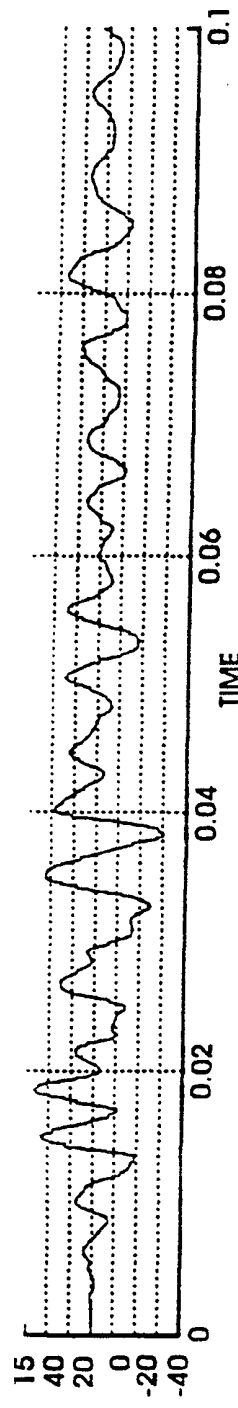

FIG. 12A 4

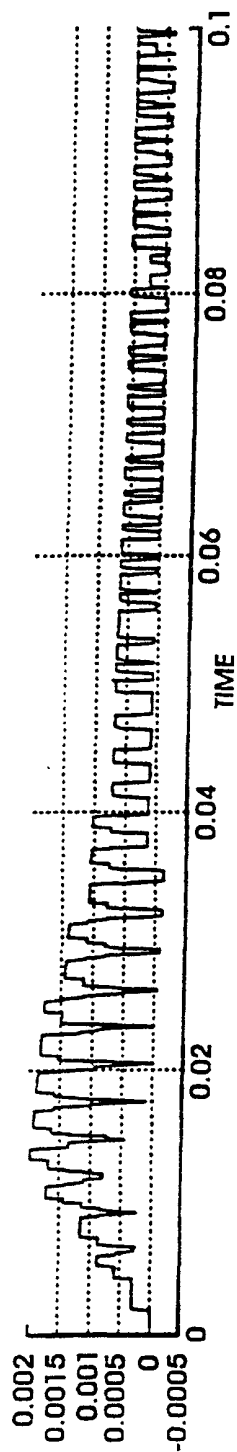

FIG. 12A 5

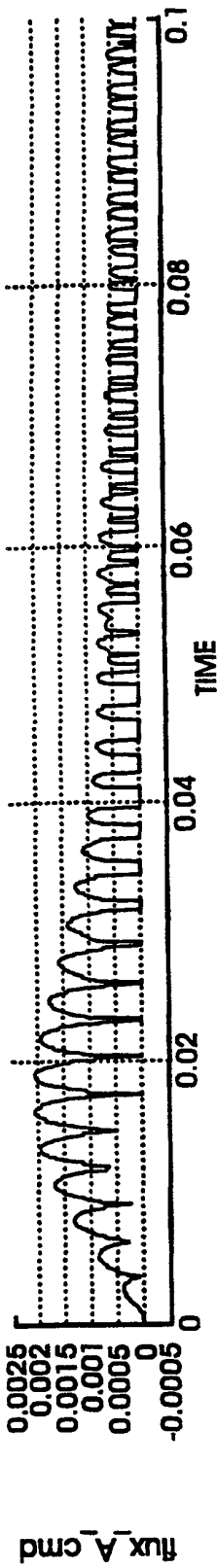

FIG. 12A 6

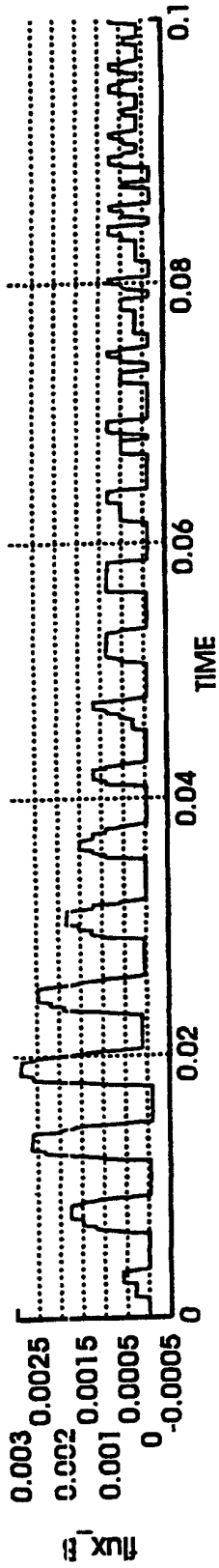

FIG. 12A 7

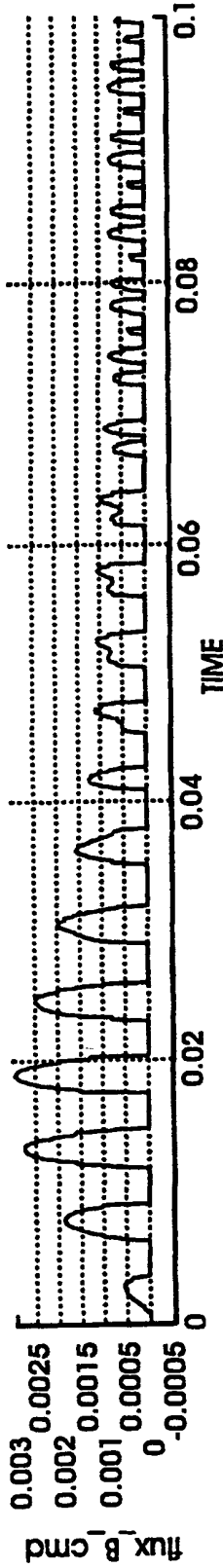

FIG. 12A 8

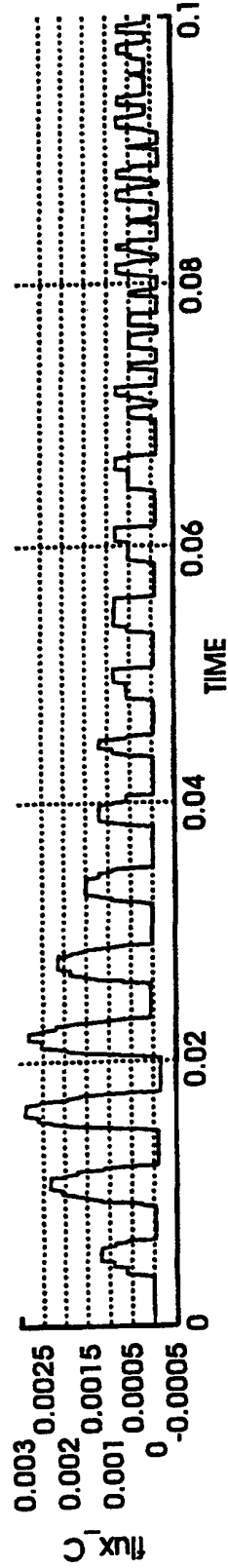

FIG. 12A 9

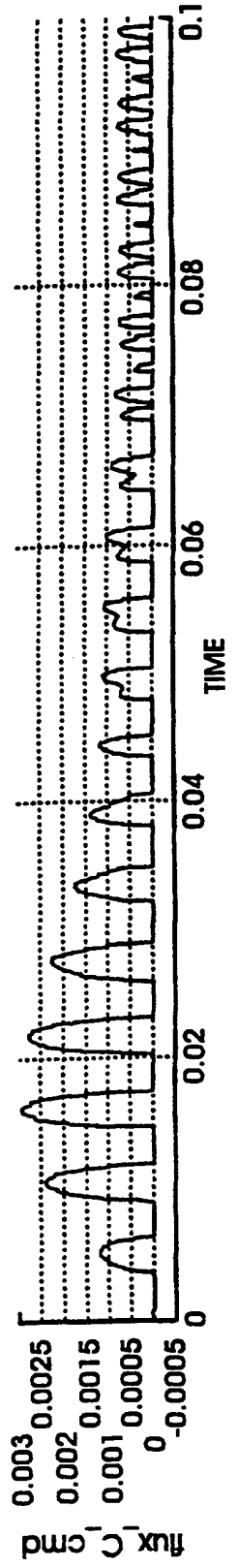

FIG. 12A 10

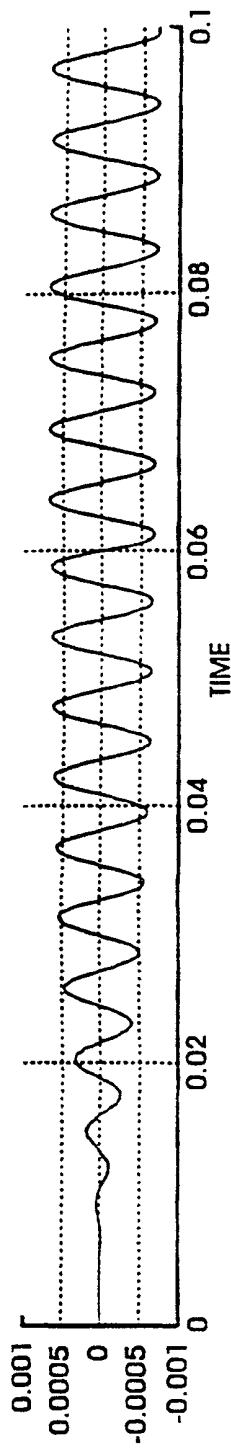

FIG. 12B 1

x

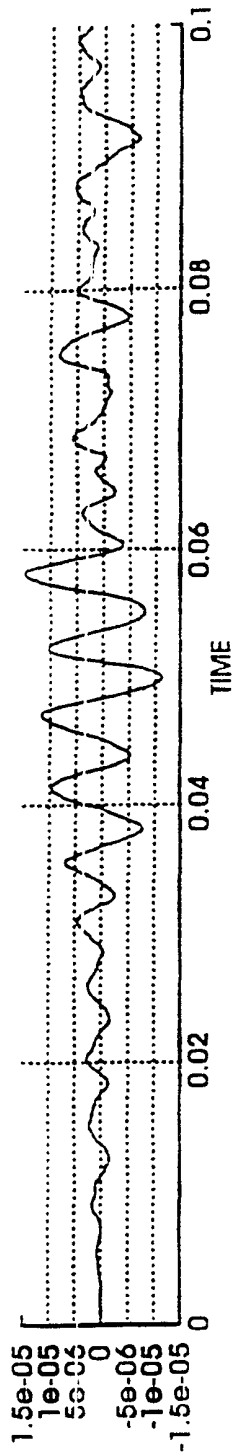

FIG. 12B 2

y

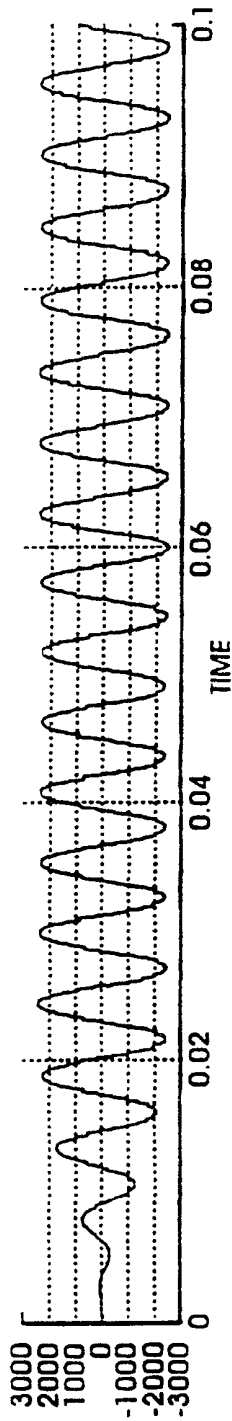

FIG. 12B 3

z

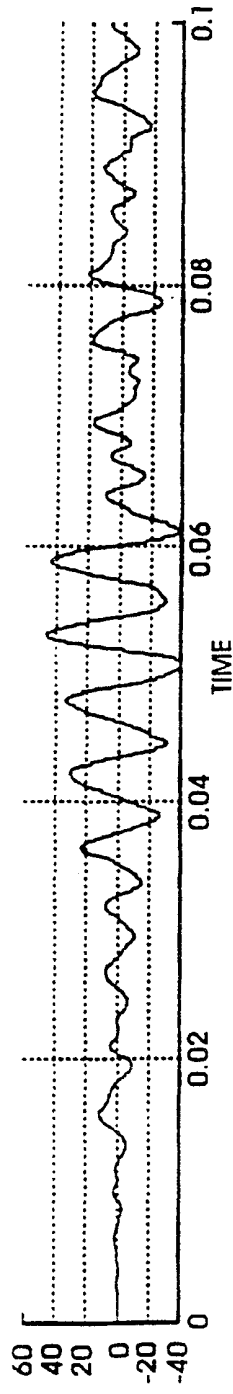

FIG. 12B 4

z

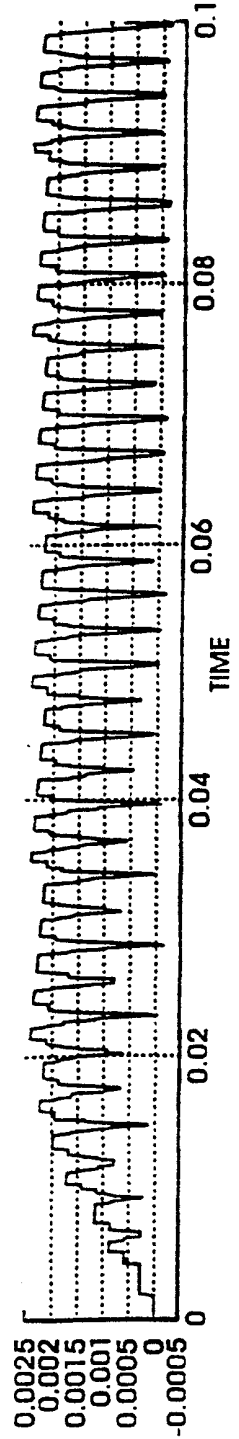

FIG. 12B 5

flux

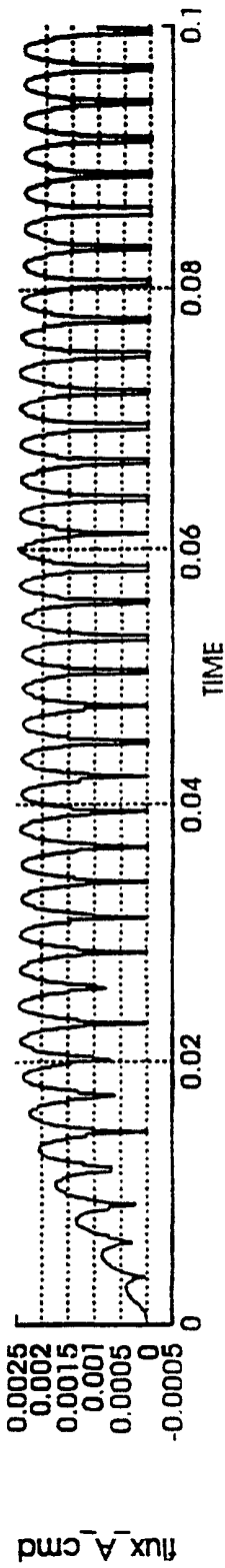

FIG. 12B 6

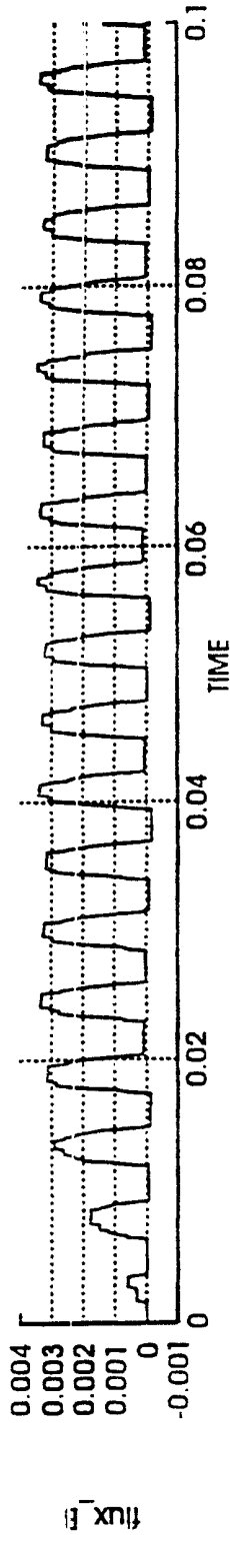

FIG. 12B 7

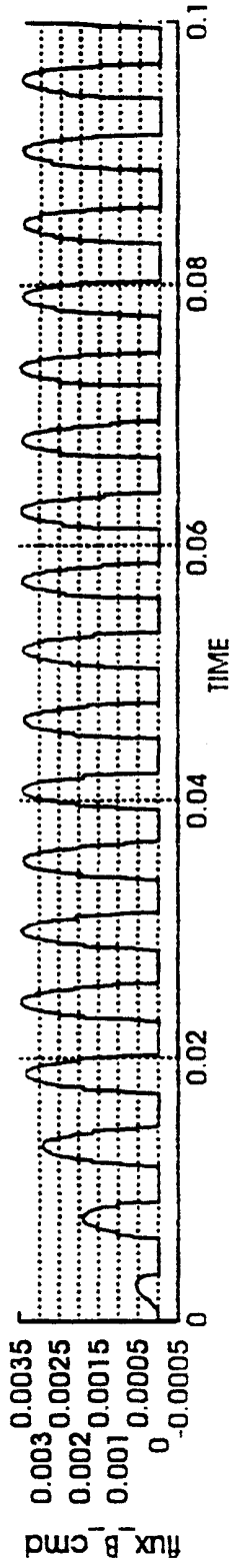

FIG. 12B 8

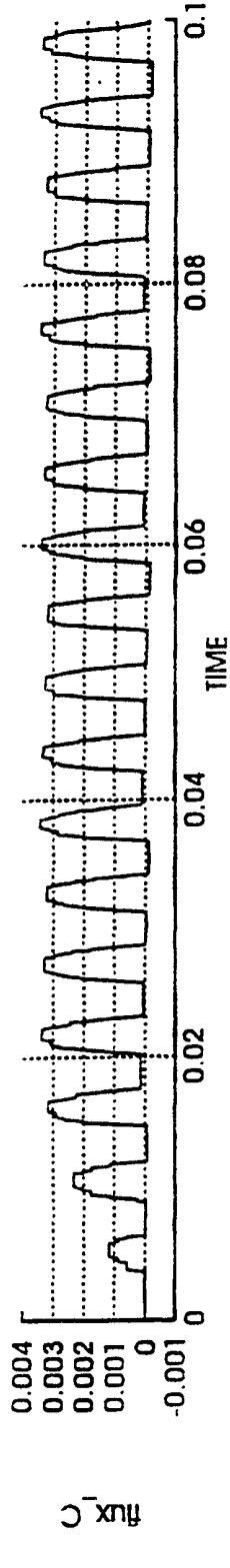

FIG. 12B 9

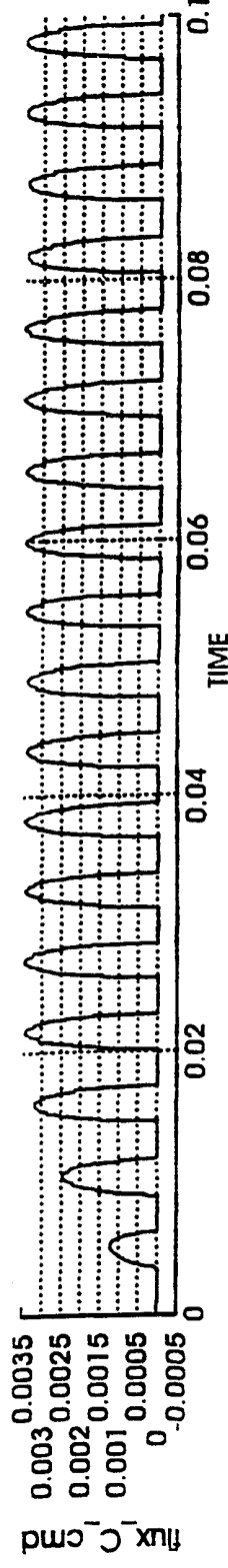

FIG. 12B 10

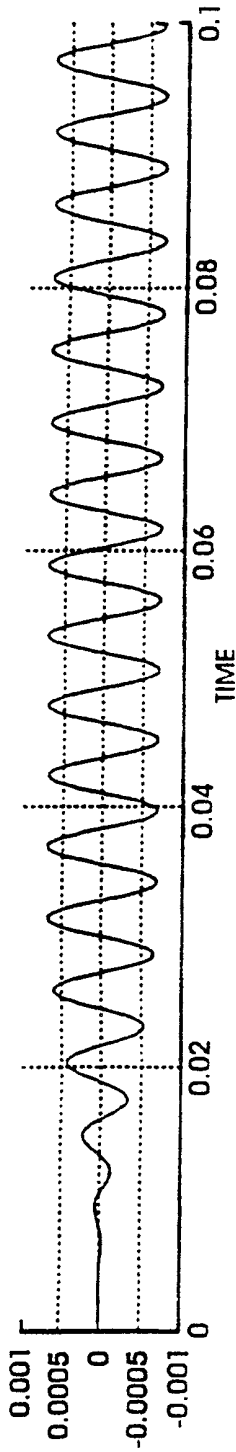

FIG. 12C 1 X

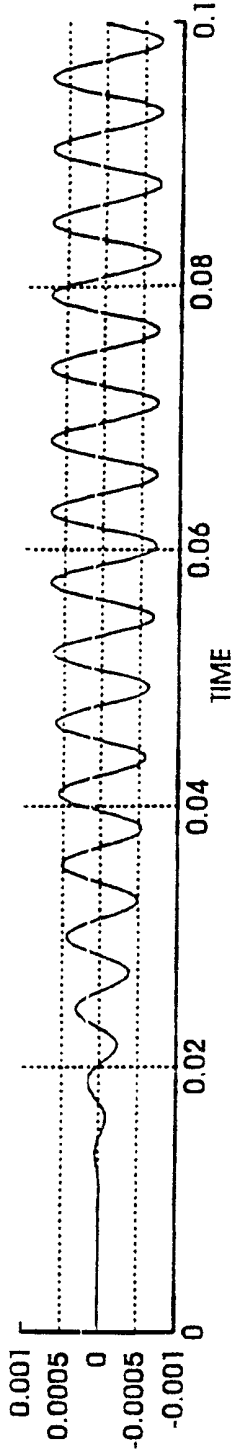

FIG. 12C 2 Y

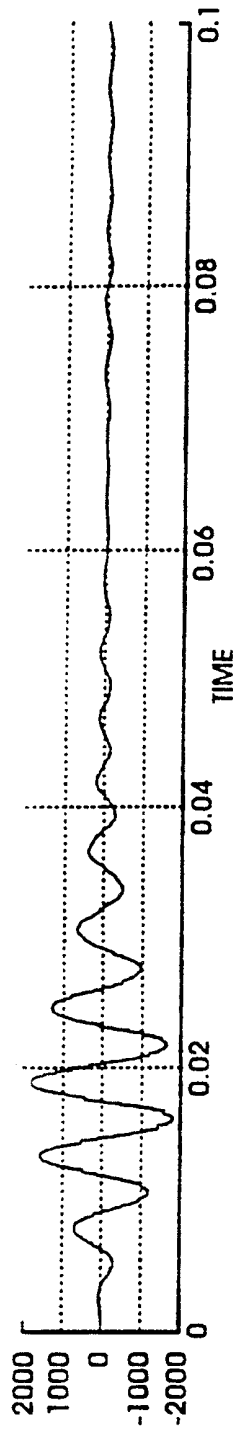

FIG. 12C 3 FX

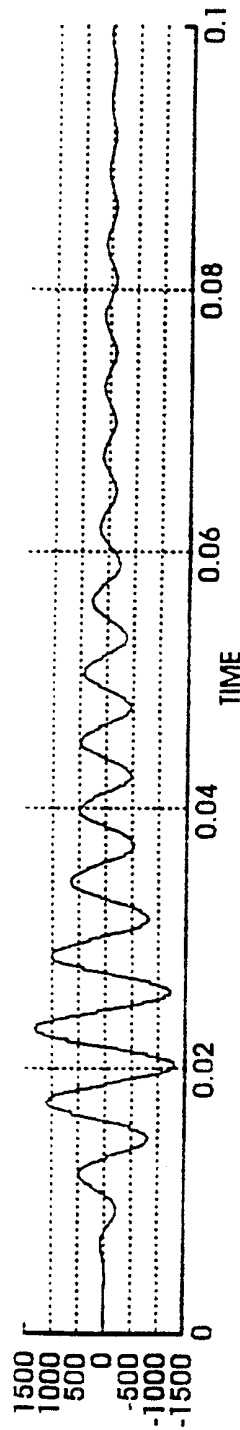

FIG. 12C 4 FY

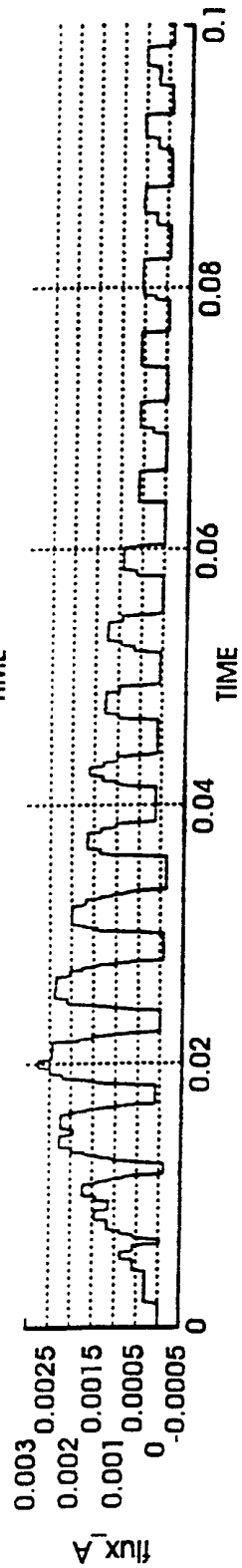

FIG. 12C 5 flux A

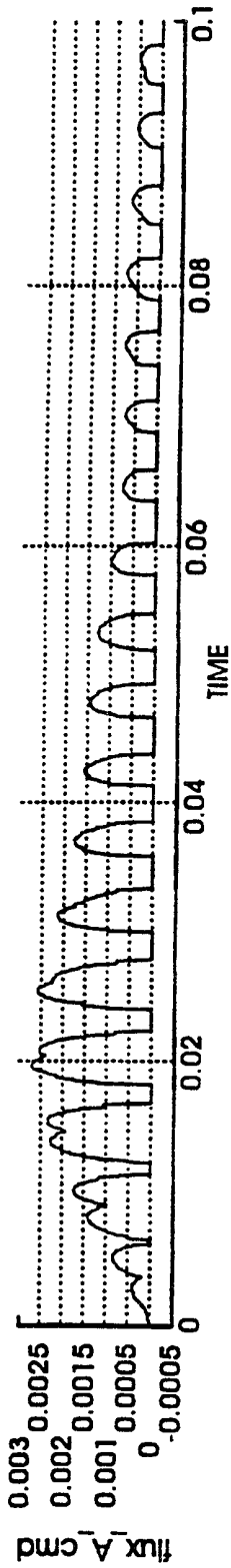

FIG. 12C 6

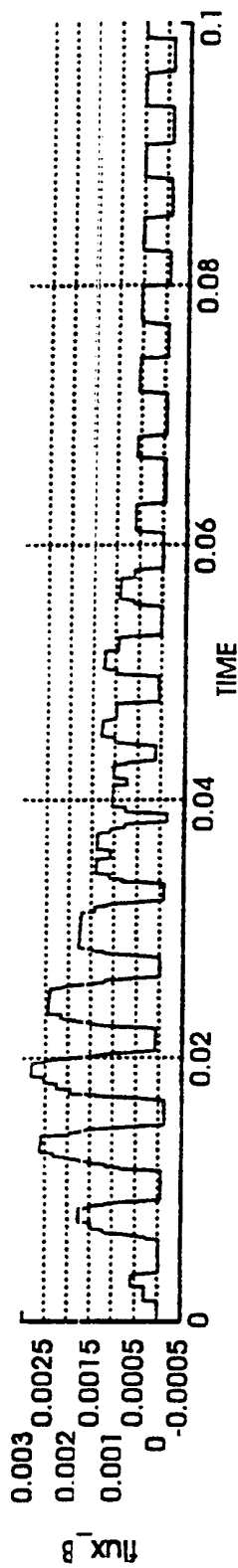

FIG. 12C 7

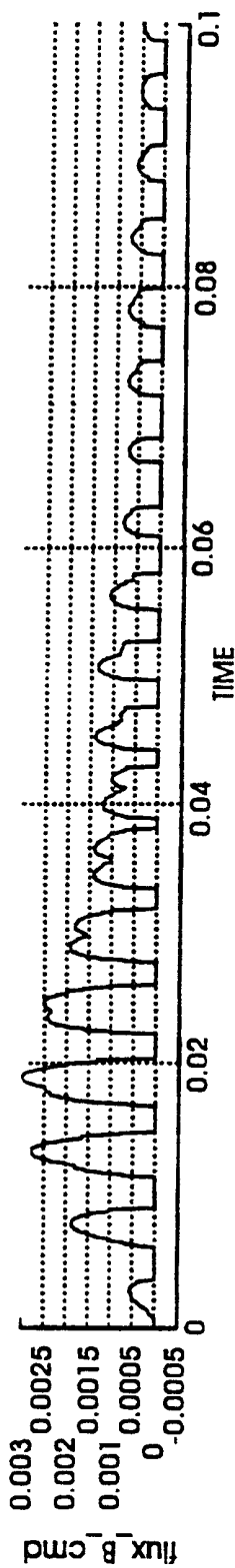

FIG. 12C 8

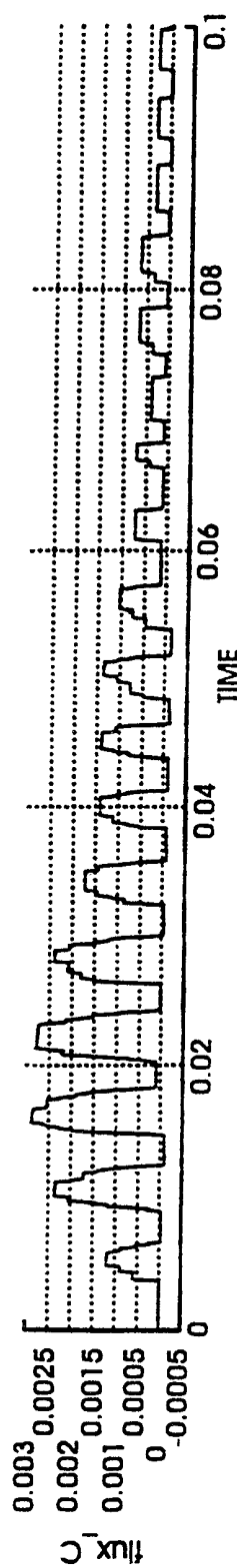

FIG. 12C 9

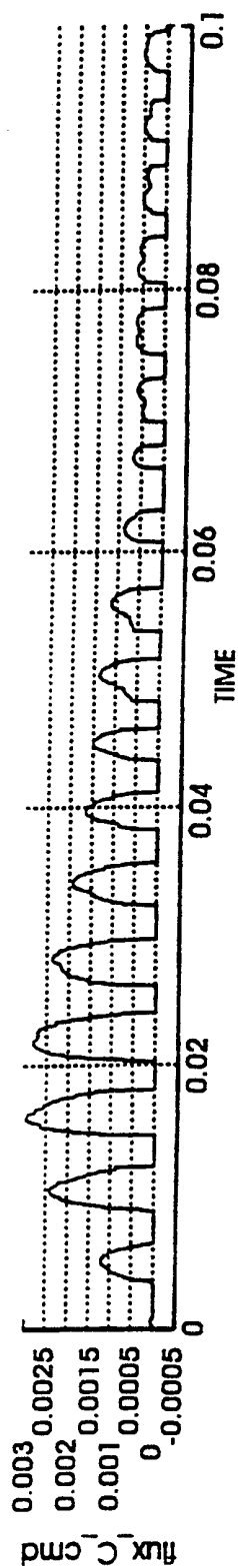

FIG. 12C 10

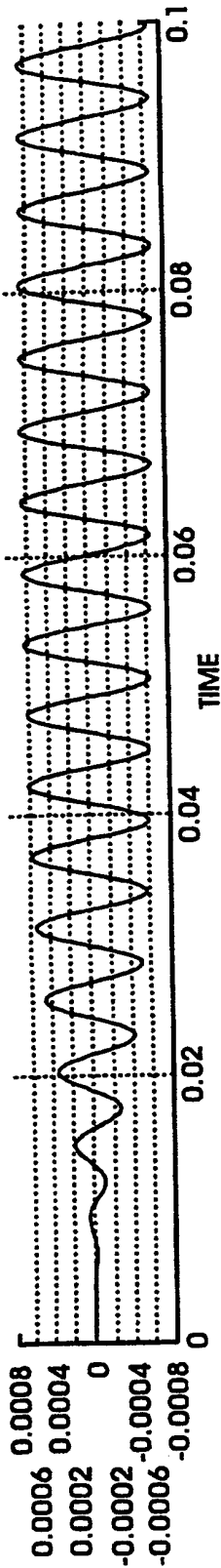

FIG. 12D 1

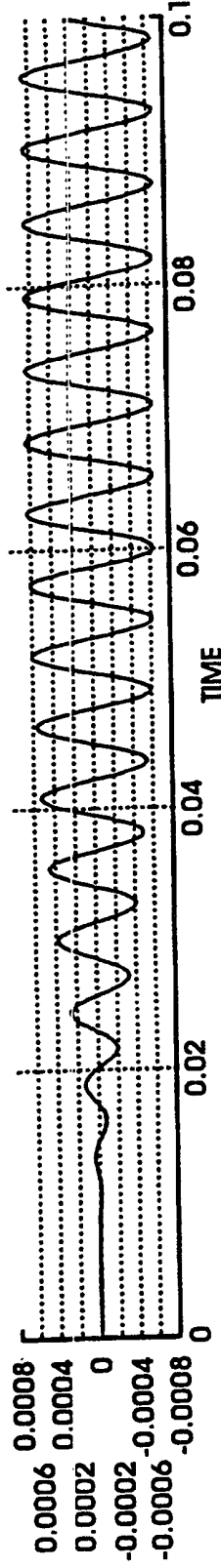

FIG. 12D 2

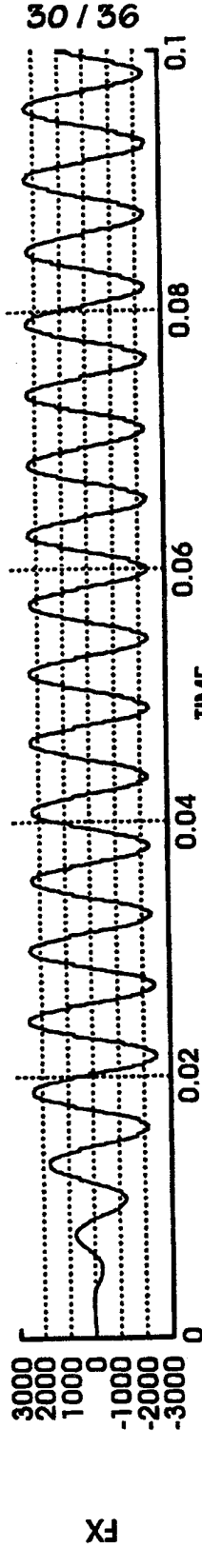

FIG. 12D 3

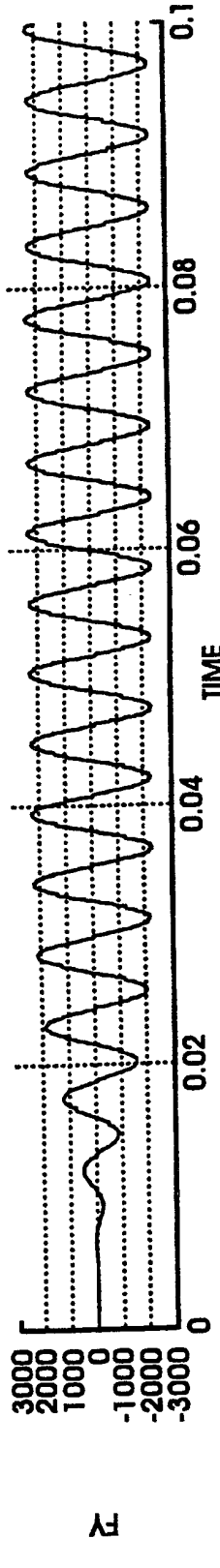

FIG. 12D 4

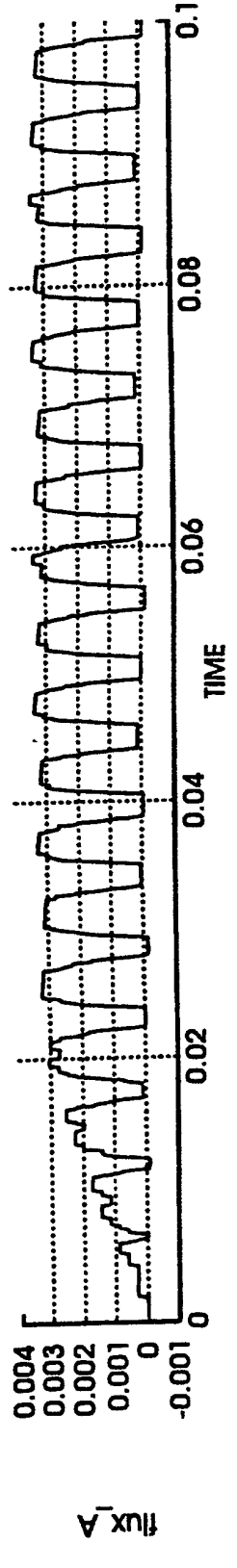

FIG. 12D 5

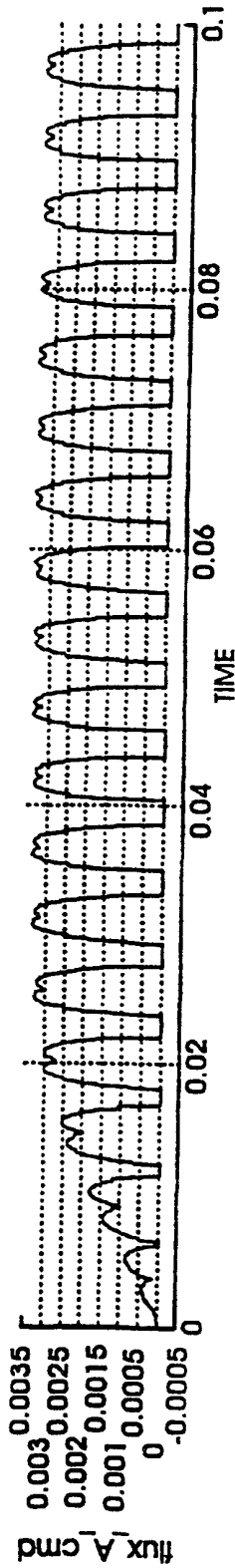

FIG. 12D 6

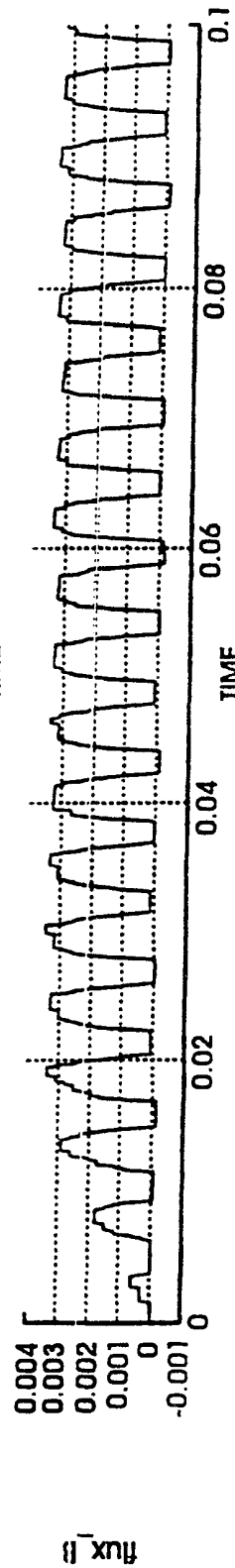

FIG. 12D 7

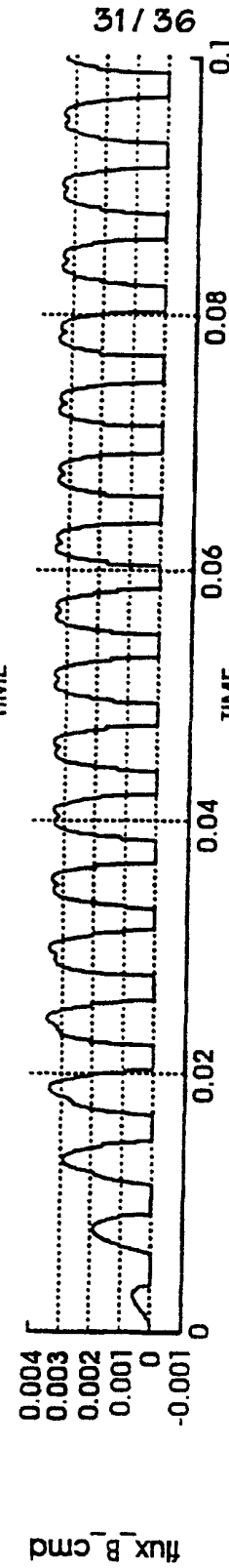

FIG. 12D 8

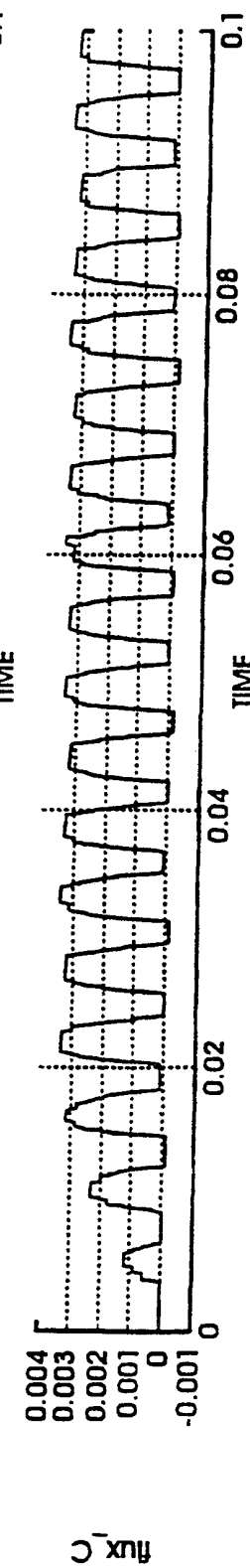

FIG. 12D 9

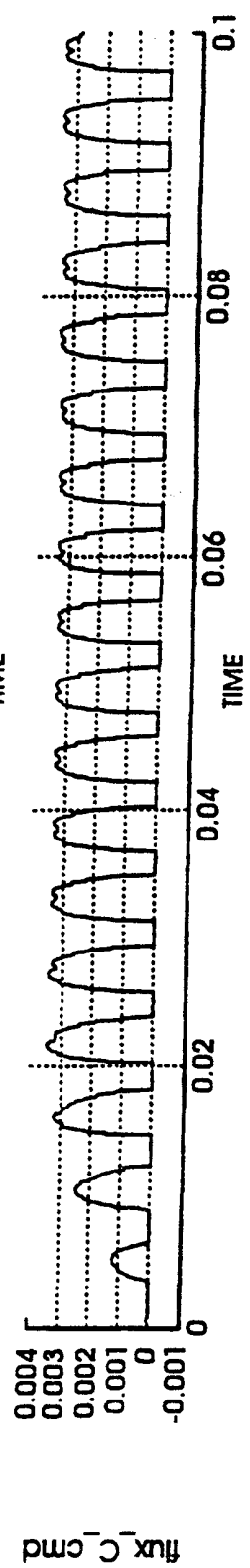

FIG. 12D 10

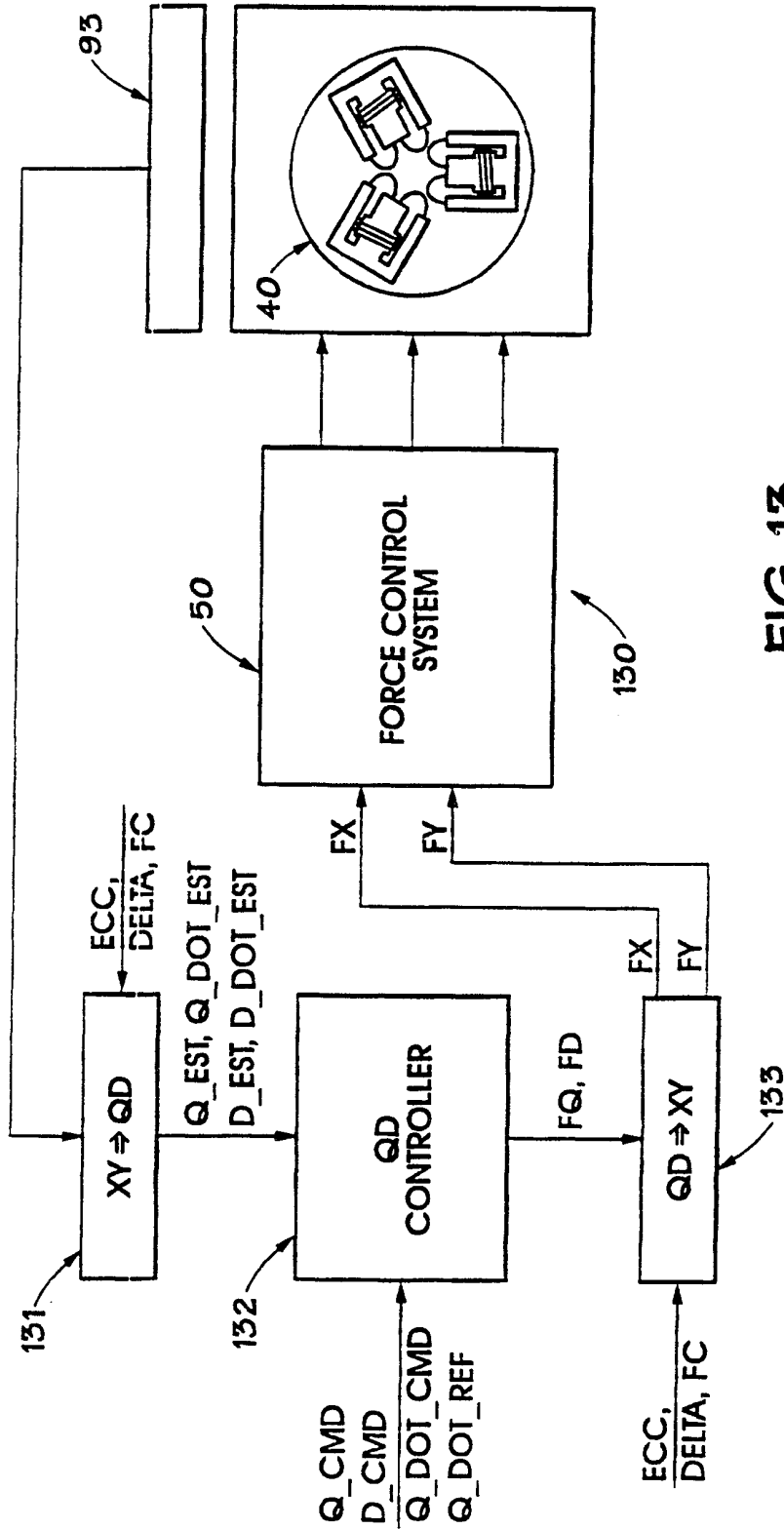

FIG. 13

TYPE = STATE - SPACE SYSTEM		ID = 97
BLOCK NAME	INPUTS	STATES
K_QD_sfbk <input checked="" type="checkbox"/>	4	2
	OUTPUTS	0
	%KQD_fbk	
2 - BY - 4 STATE SPACE MATRIX		
1.00D+05 9.19D+06 8000. -400.		
-9.19D+06 1.00D+05 400. 8000.		
ZERO INITIAL CONDITIONS : YES		
INPUT EXTERNAL_SIGNALS	OUTPUT LABELS	
1 "eq 1"	1 "eQ"	
2 "ed 1"	2 "eD"	
3 "eq 2"		
4 "ed 2"		
	COMMENTS	
<input type="button" value="CANCEL"/>	VIEW_INPUT	EXTERNAL_SIGNALS
	COLOR	0
	ALT. SPEC	SHOW_ALL
	IN_PINS	OUT_PINS
	SHOW_ALL	SHOW_ALL
	LABELS	ON
		<input type="button" value="DONE"/>

FIG. 14B

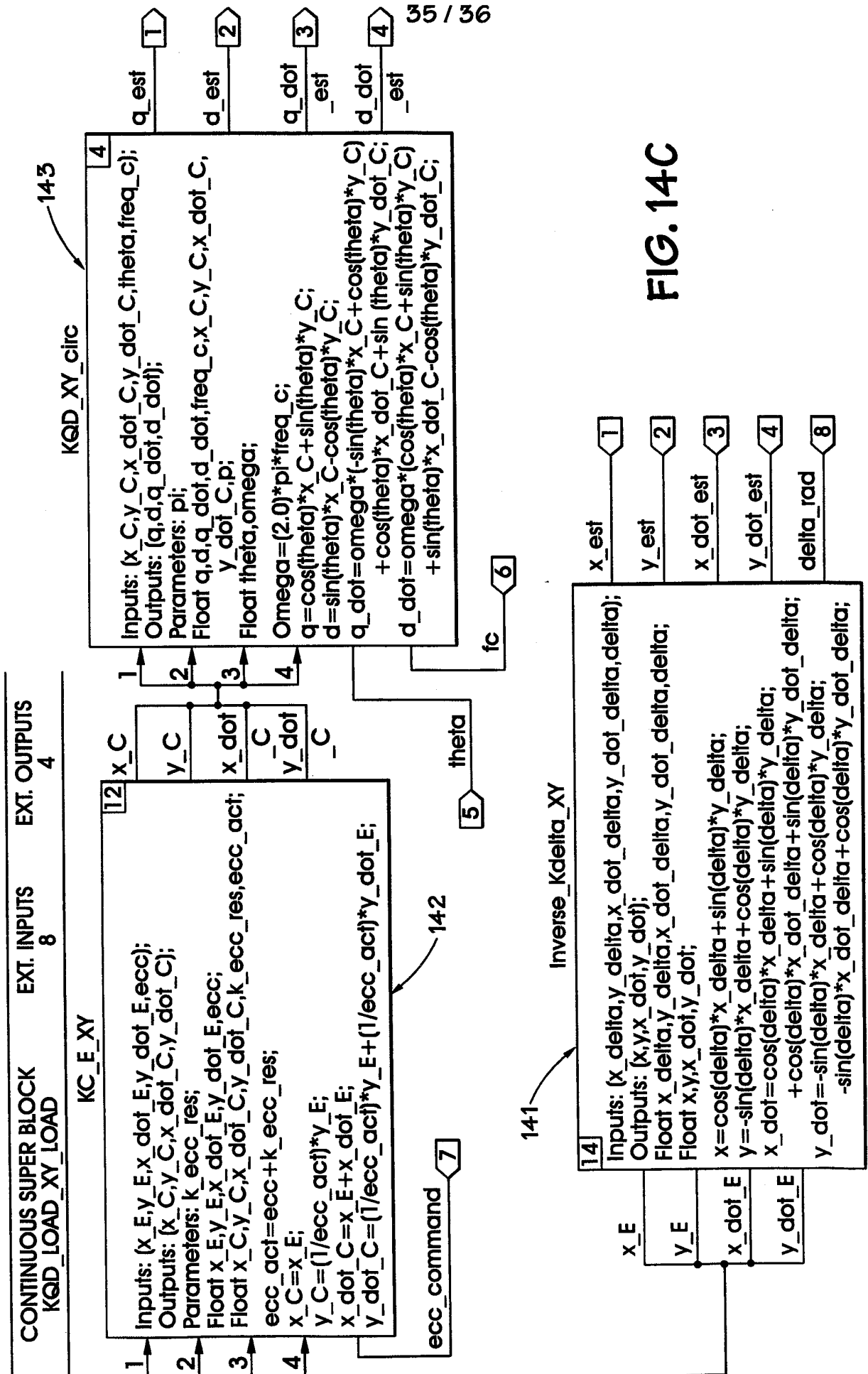

FIG. 14C

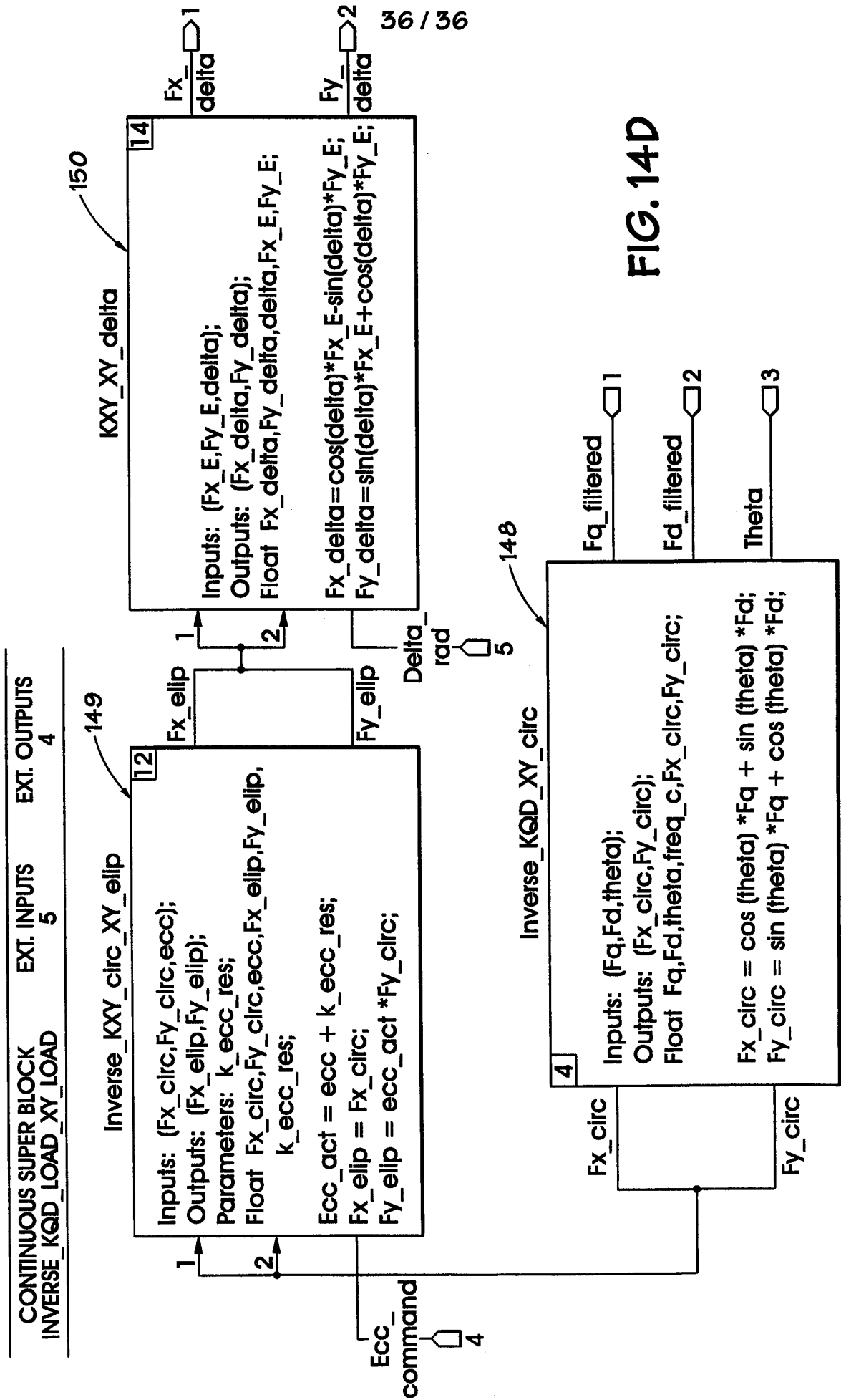

FIG. 14D

INTERNATIONAL SEARCH REPORT

International Application No
PCT/IB 99/01142

A. CLASSIFICATION OF SUBJECT MATTER IPC 6 B23K20/12 H02P7/00 B06B1/02		
According to International Patent Classification (IPC) or to both national classification and IPC		
B. FIELDS SEARCHED Minimum documentation searched (classification system followed by classification symbols) IPC 6 B23K H02P G05F H02K B29C G01D H01F B06B F16C		
Documentation searched other than minimum documentation to the extent that such documents are included in the fields searched		
Electronic data base consulted during the international search (name of data base and, where practical, search terms used)		
C. DOCUMENTS CONSIDERED TO BE RELEVANT		
Category	Citation of document, with indication, where appropriate, of the relevant passages	Relevant to claim No.
X	US 4 274 040 A (SPIEGEL) 16 June 1981 (1981-06-16) abstract column 2, line 13-31 column 2, line 52 -column 4, line 15; figures 1-3	1
X	DE 41 08 688 A (FA. CARL ZEISS) 17 September 1992 (1992-09-17) abstract page 4, line 55 -page 5, line 52; figures 3-5	1,8-11
X	US 4 715 523 A (LEBEDEV ET AL.) 29 December 1987 (1987-12-29)	1,11
A	abstract column 3, line 3 -column 6, line 7; figures 1-3	15
--- -/--		
<input checked="" type="checkbox"/> Further documents are listed in the continuation of box C.		
<input checked="" type="checkbox"/> Patent family members are listed in annex.		
* Special categories of cited documents :		
"A" document defining the general state of the art which is not considered to be of particular relevance	"T" later document published after the international filing date or priority date and not in conflict with the application but cited to understand the principle or theory underlying the invention	
"E" earlier document but published on or after the international filing date	"X" document of particular relevance; the claimed invention cannot be considered novel or cannot be considered to involve an inventive step when the document is taken alone	
"L" document which may throw doubts on priority claim(s) or which is cited to establish the publication date of another citation or other special reason (as specified)	"Y" document of particular relevance; the claimed invention cannot be considered to involve an inventive step when the document is combined with one or more other such documents, such combination being obvious to a person skilled in the art.	
"O" document referring to an oral disclosure, use, exhibition or other means	"&" document member of the same patent family	
"P" document published prior to the international filing date but later than the priority date claimed		
Date of the actual completion of the international search <p style="text-align: center;">29 October 1999</p>	Date of mailing of the international search report <p style="text-align: center;">05/11/1999</p>	
Name and mailing address of the ISA European Patent Office, P.B. 5818 Patentlaan 2 NL - 2280 HV Rijswijk Tel. (+31-70) 340-2040, Tx. 31 651 epo nl. Fax: (+31-70) 340-3016	Authorized officer <p style="text-align: center;">Beitner, M</p>	

INTERNATIONAL SEARCH REPORT

International Application No

PCT/IB 99/01142

C.(Continuation) DOCUMENTS CONSIDERED TO BE RELEVANT

Category	Citation of document, with indication, where appropriate, of the relevant passages	Relevant to claim No.
A	US 4 862 014 A (MYERS ET AL.) 29 August 1989 (1989-08-29) abstract column 2, line 36 -column 4, line 15; column 4, line 35 -column 5, line 46; figures 1,2 ---	1,2,5,6
A	DE 195 44 207 A (TECHNISCHE UNIVERSITÄT DRESDEN) 5 June 1997 (1997-06-05) abstract page 2, line 38 -page 3, line 23 page 4, line 17-52 page 4, line 65 -page 5, line 49; figures 1-4 ---	1,11
A	US 5 562 242 A (MANZO ET AL.) 8 October 1996 (1996-10-08) abstract column 2, line 10-54 column 2, line 64 -column 3, line 39; figures 1-6 ---	15,17, 22-26
A	US 5 378 951 A (SNYDER) 3 January 1995 (1995-01-03) cited in the application abstract column 4, line 20 -column 5, line 8 column 6, line 49 -column 7, line 44; figures 1-3,8 ---	15,17, 22-26
A	US 5 300 841 A (PRESTON ET AL.) 5 April 1994 (1994-04-05) abstract column 2, line 42 -column 6, line 8; figures 1-6 ---	1,5,8,9, 17-19, 22-24
A	US 5 140 243 A (LYONS ET AL.) 18 August 1992 (1992-08-18) abstract column 4, line 60 -column 6, line 35; figures 1-4 -----	6 27

INTERNATIONAL SEARCH REPORT

Information on patent family members

International Application No

PCT/IB 99/01142

Patent document cited in search report	Publication date	Patent family member(s)	Publication date
US 4274040 A	16-06-1981	AU 532682 B	06-10-1983
		AU 6395780 A	07-05-1981
		EP 0040205 A	25-11-1981
		IL 60967 A	31-10-1983
		JP 56501385 T	24-09-1981
		WO 8101206 A	30-04-1981
DE 4108688 A	17-09-1992	NL 9200451 A	16-10-1992
US 4715523 A	29-12-1987	DE 3638326 C	25-02-1988
		FR 2607043 A	27-05-1988
		GB 2197998 A, B	02-06-1988
US 4862014 A	29-08-1989	DE 3789218 D	07-04-1994
		DE 3789218 T	09-06-1994
		EP 0273961 A	13-07-1988
		IL 83041 A	15-04-1991
		JP 1500232 T	26-01-1989
		JP 5075122 B	19-10-1993
		WO 8800370 A	14-01-1988
DE 19544207 A	05-06-1997	NONE	
US 5562242 A	08-10-1996	FR 2714314 A	30-06-1995
		DE 69401742 D	27-03-1997
		DE 69401742 T	28-05-1997
		DE 659492 T	14-12-1995
		EP 0659492 A	28-06-1995
		ES 2073385 T	16-08-1995
		JP 7213996 A	15-08-1995
US 5378951 A	03-01-1995	US 5277744 A	11-01-1994
		US 5160393 A	03-11-1992
		AU 656661 B	09-02-1995
		AU 3564593 A	03-06-1993
		AU 659595 B	18-05-1995
		AU 6882294 A	13-10-1994
		AU 646710 B	03-03-1994
		AU 8978691 A	02-07-1992
		CA 2057978 A, C	28-06-1992
		CN 1065227 A	14-10-1992
		EP 0504494 A	23-09-1992
		JP 7088663 A	04-04-1995
		MX 9102802 A	01-06-1992
		NZ 241105 A	28-03-1994
US 5300841 A	05-04-1994	NONE	
US 5140243 A	18-08-1992	CA 2076080 A	14-03-1993
		EP 0533413 A	24-03-1993
		JP 5199794 A	06-08-1993