

(No Model.)

H. GROSS.  
BANK VAULT.

No. 370,471.

Patented Sept. 27, 1887.

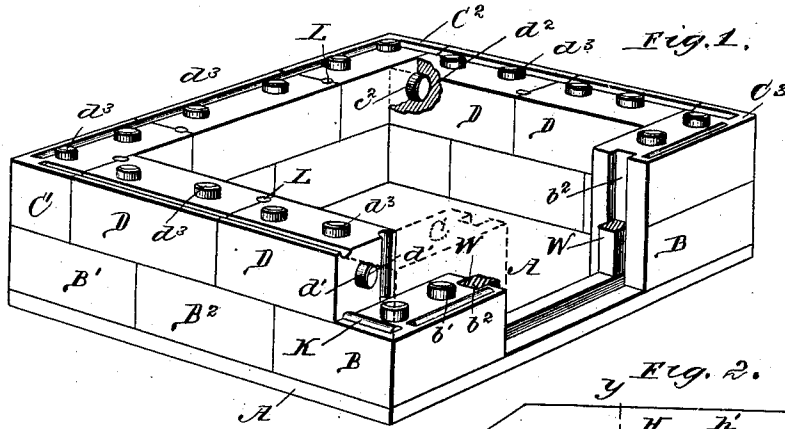

Fig. 3.

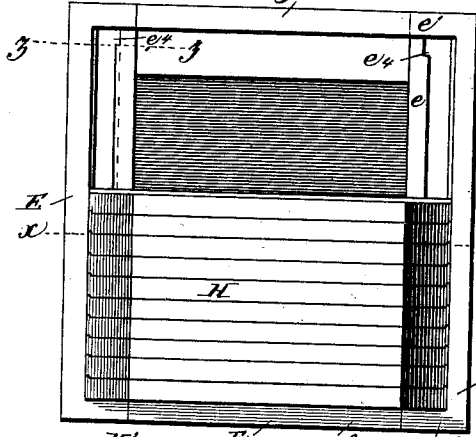

Fig. 2.

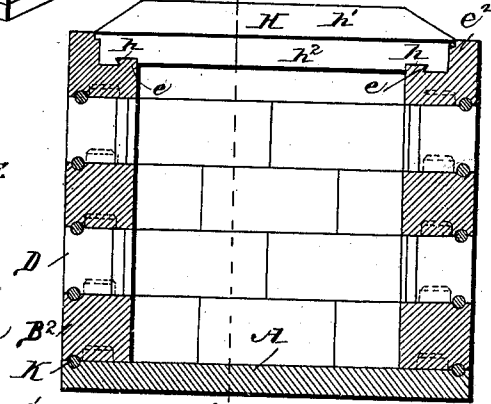

Fig. 5.

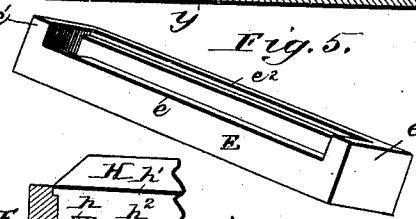

Fig. 6.

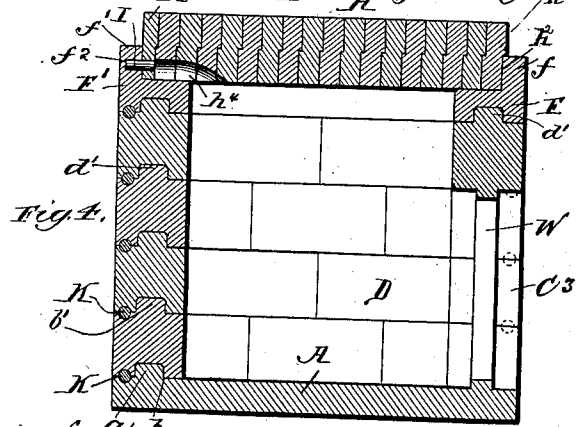
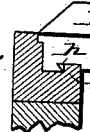

Fig. 4.

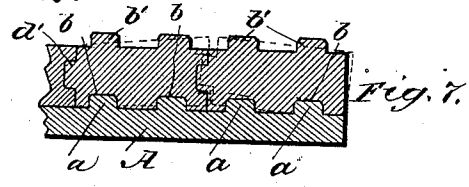

Fig. 7.

Witnesses.

*W. Russell*  
*J. Mills.*

*Inventor:*  
*Henry Gross*  
*By Price Fishman*  
*His Atty*

# UNITED STATES PATENT OFFICE.

HENRY GROSS, OF CHICAGO, ILLINOIS, ASSIGNOR TO THE CHICAGO SAFE AND LOCK COMPANY, OF SAME PLACE.

## BANK-VAULT.

SPECIFICATION forming part of Letters Patent No. 370,471, dated September 27, 1887.

Application filed March 8, 1887. Serial No. 230,086. (No model.)

*To all whom it may concern:*

Be it known that I, HENRY GROSS, a citizen of the United States, residing at Chicago, in the county of Cook and State of Illinois, have invented certain new and useful Improvements in Bank-Vaults, of which I do declare the following to be a full, clear, and exact description, reference being had to the accompanying drawings, forming part of this specification.

My present invention has relation to the class of bank-vault structures the walls whereof are formed of cast-iron blocks connected together in such manner as to prevent their disarrangement if attempt be made to forcibly enter the vault; and the object of my invention is to provide a simple and effective construction of blocks whereby, without the aid of supplemental bolts, the various blocks of the wall structure may be firmly bound together as the blocks are set in place.

To this end my invention consists, primarily, in providing the blocks whereof the vault-walls are composed with suitable dowels and seats or sockets to receive said dowels, so that when the blocks have been properly set the dowels will occupy such position with respect to the adjoining blocks as to securely guard against forcible displacement of any block of the series.

My invention also consists in the various novel features of construction, hereinafter described, illustrated in the accompanying drawings, and particularly defined in the claims at the end of this specification.

Figure 1 is a perspective view of a portion of a bank-vault embodying my invention, the first two rows of blocks only being illustrated and one of the corner blocks being removed. Fig. 2 is a view in vertical transverse section on line  $x x$  of Fig. 3. Fig. 3 is a plan view of the vault, a number of the roof-bars being removed to illustrate subjacent parts. Fig. 4 is a view in central vertical section on line  $yy$  of Fig. 2. Fig. 5 is a detail perspective view of one of the side roof-supporting blocks. Fig. 6 is a detail view in vertical section on line  $z z$  of Fig. 3, one of the side roof-supporting blocks being shown in side elevation. Fig. 7 is a view in vertical longitudinal section of a

part of the vault-floor, two of the blocks being shown in position thereon.

A designates the floor or base-plate of the bank-vault, on the upper surface of which, near the edges thereof, will be formed suitable dowels,  $a$ , adapted to enter the dowel-seats  $b$ , formed in the undersides of the several corner blocks B and B' and intermediate blocks B<sup>2</sup> comprising the base layer of blocks and resting upon the base-plate or floor A. It will be understood, however, that, if desired, the dowels may be formed upon the blocks and dowel-seats be formed within the base-plate; or the bottom row of blocks may be merely bolted to the surface of the floor or base-plate. The base corner blocks B adjacent to the doorway are each preferably provided with a suitable channel,  $b^2$ , adapted to receive one of the bars W, forming part of the door-frame of the vault, and the opposite end of each of said base corner blocks will be provided with a seat adapted to receive a corresponding dowel formed upon the adjacent end of the intermediate base-block; or, if the base-blocks B, B', and B<sup>2</sup> be securely bolted to the base-plate A of the vault, it will be unnecessary to provide them with end dowels and dowel-seats whereby they may interlock.

It will be observed that the base corner blocks B and B' are shown as of angular shape, while the blocks above them are plain blocks jointed together, as will be presently explained.

Above the base-blocks B, B', and B<sup>2</sup> are placed the corner blocks C C' and C<sup>2</sup> C<sup>3</sup> and the intermediate blocks D, these several corner blocks and intermediate blocks being provided, respectively, with the dowel-seats upon their under sides to receive the upwardly-projecting dowels  $b'$  of the base-blocks. The corner blocks C and C<sup>3</sup> are also provided upon their inner sides or faces with suitable seats adapted to receive the dowels  $d'$ , formed upon the ends of the adjacent intermediate blocks D, and the corner blocks C and C<sup>3</sup> next to the doorway have their outer ends preferably grooved or channeled similarly to the base corner blocks, so as to form a space for the admission of the side bars of the door-frame. The rear corner blocks, C' and C<sup>2</sup>, are provided

upon their inner faces with the dowels  $d^2$ , adapted to enter the sockets  $d^2$ , formed in the adjacent ends of the blocks D, and it will be observed that the several corner blocks C C' and C<sup>2</sup> C<sup>3</sup> and intermediate blocks D are each provided upon their upper surface with the dowels  $d^3$ , adapted to enter corresponding seats formed in the under sides of the superposed corner and intermediate blocks. Assuming the row of base-blocks B, B', and B<sup>2</sup> to have been placed in position, it will be readily seen that the wall structure can be conveniently built up by first placing a corner block C upon the front part of the base corner block B, and the dowels  $b'$  of this base corner block entering the corresponding dowel-seats formed in the under surface of the corner block C, after which the next intermediate block D will be placed in position upon the corner block B and the adjacent base-block B<sup>2</sup>, in such manner that the end dowel,  $d'$ , of this block D shall enter the dowel-seat formed in the inner faces or side of the corner block C. In this manner, also, each row of blocks will be successively set in place, the dowels of one block entering suitable seats in the blocks adjacent thereto. In order to permit the blocks to be more readily set together, the dowels upon the several blocks are preferably formed slightly tapering or rounded at the ends, so as to permit them to more readily enter the sockets of the adjacent blocks, and, as will be seen by reference to the dotted lines, Fig. 7, the blocks will be slightly inclined when the dowels are being set into their appropriate seats. In this manner each successive row of blocks will be set in position until the top of the wall structure is reached, when the side block, E, and end blocks, F F', which serve to support the roof of the vault, will be set.

The side blocks, E, are provided upon their under surface with suitable dowel-seats adapted to receive the dowels projecting from the upper surfaces of each of the corner blocks and intermediate blocks immediately subjacent thereto, and the end roof-supporting blocks, F and F', are in like manner provided with sockets adapted to receive the dowels projecting from the upper surfaces of the subjacent blocks of the front and rear walls of the vault.

Each roof-supporting side block, E, is provided upon its upper surface with a dovetail rib,  $e$ , at the ends of which rise the flanges  $e'$ , and parallel with which extend the upright flanges  $e^2$ . The end roof-supporting block F is provided upon its upper surface with the upwardly-projecting flange or web  $f$ . The rear roof-supporting end block, F', is provided upon its upper surface with a web or rib,  $f'$ , having the perforation  $f^2$  formed therein. When the blocks forming the wall structure have been built to the desired height, the side roof-supporting blocks, E, will be placed in position upon the side walls of the vault, their dowel-sockets receiving the dowels of the sub-

jacent blocks, and the end roof-supporting blocks, F and F', will next be placed upon the front and rear walls of the vault structure, the ends of these blocks F and F' abutting against the inner faces of the side blocks, E. The structure will now be in readiness to receive the bars H, of which the roof of the vault will be formed, and it will be observed that each of these bars is provided near its ends with a dovetail groove corresponding to the dovetail rib formed upon the upper surface of each of the side blocks, E, and each of these roof-bars is also provided upon its opposite faces with a longitudinal shoulder,  $h'$ , corresponding to the longitudinal cut-away space  $h^2$ , so that when the several bars comprising the roof have been set in proper position the shoulders  $h'$  of one bar shall enter the corresponding channels or spaces,  $h^2$ , in the adjacent bar of the series.

It will be observed that the dovetail ribs of the side roof-supporting blocks, E, are cut away at their inner ends, as shown at  $e^4$ , so that when the roof-bars H are set over the dovetail ribs at these points such bars, as they are moved toward the front of the vault, will be held by the dovetail ribs entering their corresponding grooves  $h$ , and firmly guard them against danger of vertical displacement.

As the last roof-bar of the series will come opposite the cut-away spaces  $e^4$  of the dovetail ribs of the side roof-supporting blocks, it is necessary to provide means for locking such rear roof-bar in position, and this I accomplish by embodying a guard-pin, I, in the rear bar, H', and in the adjacent flange  $f^2$  of the rear roof-supporting block, F', in order to permit this guard-pin I to be set from the inside of the vault. The under portion of the last two or three roof-bars H will be cut away, as shown at  $h^4$ , the advantage of setting this guard-pin from the inside being that it cannot be tampered with from the outside of the vault.

It will be observed that the horizontal surfaces of the various blocks composing the wall structure are provided with semi-cylindrical grooves or channels adapted to receive the rods or bars K, which, as the building of the walls progresses, can be laid between each course of blocks, the purpose of these rods being to give an irregular outline to the joint between the blocks, so that all danger of the introduction of explosives or the forcible entrance of the vault through the joints may be avoided. In like manner, also, the abutting ends of the blocks whereof the walls are built are provided with semi-cylindrical channels or grooves, adapted to receive the short wires or rods L, which give to the joints an irregular outline.

It will be readily understood that the precise shape and size of the various blocks will depend upon the dimensions of the vault structure, and can be readily varied without departure from the invention.

I do not wish to be understood as claiming

in this application the roof construction or any other features illustrated in the application filed by me of even date herewith.

5 Having thus described my invention, what I claim as new, and desire to secure by Letters Patent, is—

10 1. A bank-vault the walls of which comprise metal corner blocks and intermediate metal blocks provided with dowel pins and sockets, whereby said blocks can be inter-

15 2. A bank-vault the walls of which comprise metal blocks provided upon their horizontal faces and vertical end faces with dowel pins and sockets, substantially as described.

3. A bank-vault the walls of which comprise metal corner blocks provided upon their horizontal faces, upon their vertical inner faces, and upon their inner ends with dowel pins and sockets, substantially as described. 20

4. A bank-vault the walls of which comprise metal blocks provided with open channels upon their horizontal adjoining faces, in combination with rods located within said channels, substantially as described.

HENRY GROSS.

Witnesses:

GEO. P. FISHER, Jr.,  
J. H. PEIRCE.