

No. 731,404.

PATENTED JUNE 16, 1903.

C. N. E. GRAY.
BROADCAST SEEDING MACHINE.

APPLICATION FILED DEC. 5, 1902.

NO MODEL.

3 SHEETS—SHEET 1.

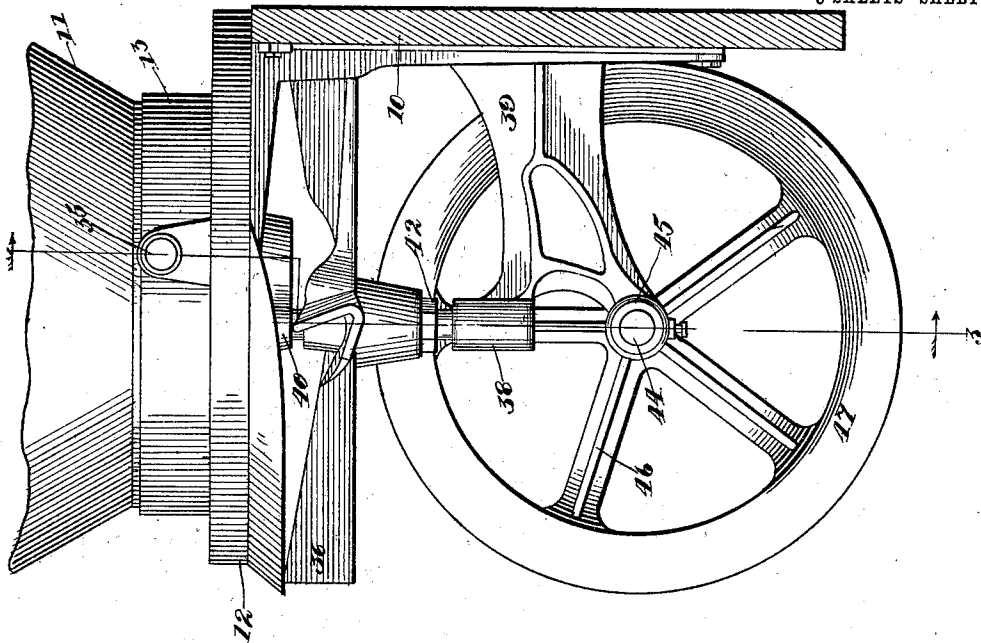

Fig. 1.

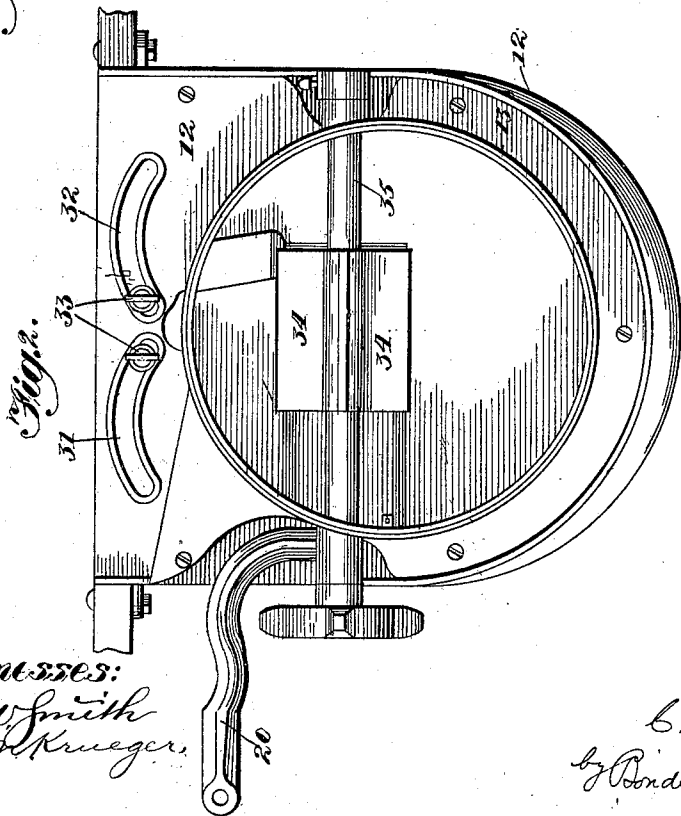

Fig. 2.

Witnesses:
C. W. Smith
H. M. Krueger.

Inventor:
Christian N. E. Gray,
by Bond Adams, Richard Jackson,
his Attys.

No. 731,404.

PATENTED JUNE 16, 1903.

C. N. E. GRAY,
BROADCAST SEEDING MACHINE.

APPLICATION FILED DEC. 5, 1902.

NO MODEL.

3 SHEETS—SHEET 2.

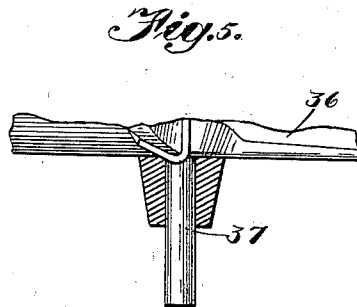
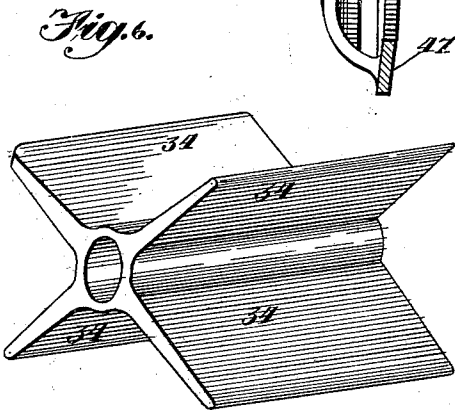
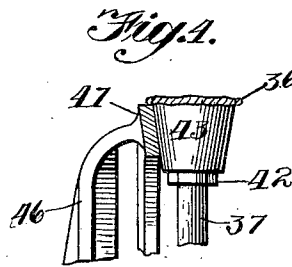
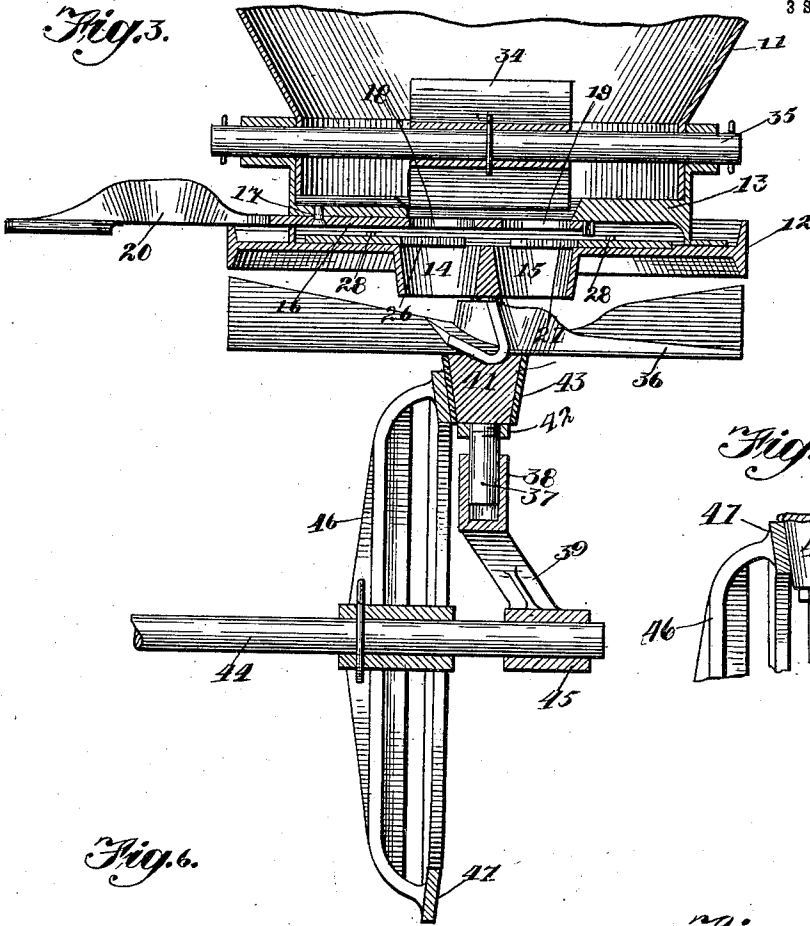

Witnesses:
C. W. Smith
H. M. Krueger

Inventor:
 Christian N. E. Gray,
 by *W. H. Adams* *Richard J. Mason*
 his Attys.

C. N. E. GRAY.
BROADCAST SEEDING MACHINE.

APPLICATION FILED DEC. 5, 1902.

NO MODEL.

3 SHEETS—SHEET 3.

Fig. 1.

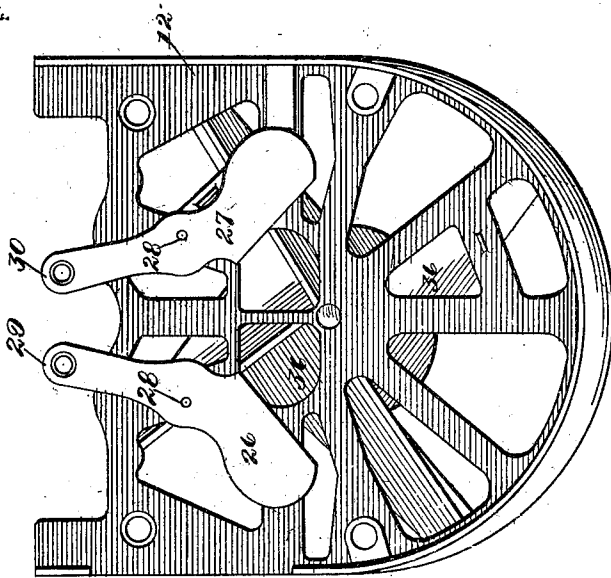
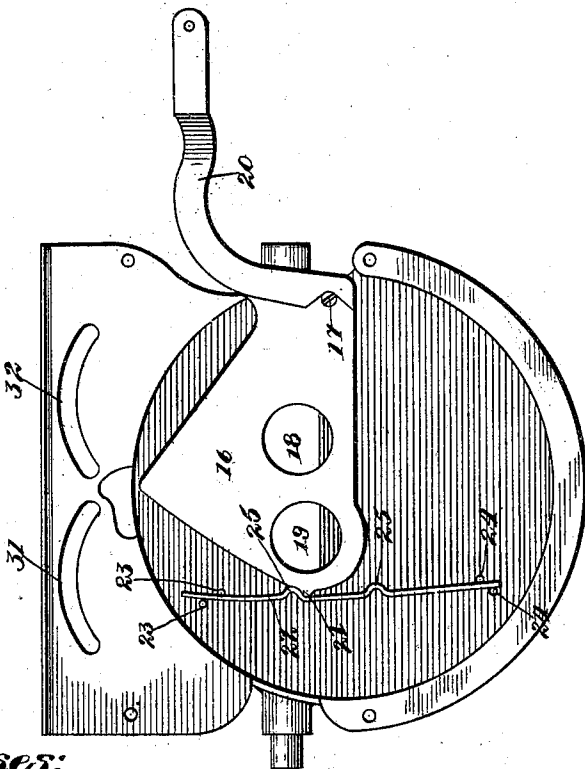

Fig. 8.



Witnesses:
C. W. Smith
H. M. Krueger

Inventor:
Christian N. E. Gray,
by Donald Hamilton Jackson,
his Atty.

UNITED STATES PATENT OFFICE.

CHRISTIAN N. E. GRAY, OF DECATUR, ILLINOIS, ASSIGNOR TO HIMSELF
AND CHAMBERS, BERING QUINLAN COMPANY, OF DECATUR, ILLINOIS,
A CORPORATION OF ILLINOIS.

BROADCAST SEEDING-MACHINE.

SPECIFICATION forming part of Letters Patent No. 731,404, dated June 16, 1903.

Application filed December 5, 1902. Serial No. 134,019. (No model.)

To all whom it may concern:

Be it known that I, CHRISTIAN N. E. GRAY, a citizen of the United States, residing at Decatur, in the county of Macon and State of Illinois, have invented certain new and useful Improvements in Broadcast Seeding-Machines, of which the following is a specification, reference being had to the accompanying drawings.

My invention relates to broadcast seeding-machines, and has for its object to provide an improved construction by which the objectionable noise incident to the operation of seeders as commonly heretofore constructed will be avoided. In my Letters Patent No. 713,300, dated November 11, 1902, I have described an improved construction in which the distributing-fan is rotated by frictional engagement with a friction-wheel mounted upon a horizontal drive-shaft, the friction-wheel being held in operative contact with a friction-pinion mounted on the shaft which carries the distributing-fan by means of spring mechanism.

My present invention involves certain improvements by which the use of a spring is avoided, the friction drive-wheel being fixedly secured upon its supporting-shaft instead of movably secured thereupon, as in the construction of my former patent. By my present construction, furthermore, I provide a construction by which the friction-wheels may adjust themselves with reference to each other to accommodate inequalities, so that a satisfactory frictional engagement is at all times secured. I accomplish this result by mounting the friction drive-wheel fixedly upon its horizontal shaft, as already stated, and mounting the friction-pinion, which is connected with the distributing-fan, either upon a longitudinally-adjustable vertical shaft or by mounting the friction-pinion loosely upon a vertical shaft, so that it is free to move longitudinally upon said shaft. In either case the pinion is held in contact with the friction drive-wheel by gravity, the weight of the distributing-fan serving to provide sufficient pressure to secure proper operation. The operating-face of the friction drive-wheel and the periphery of the friction-

pinion are beveled, so that downward movement of the pinion increases the pressure of said pinion against the drive-wheel.

Another improvement relates to the devices by which the feed is controlled and involves improved mechanism for controlling the position of the cut-off shutter by which the size of the opening leading from the seedbox or hopper to the distributing-fan is regulated.

In the accompanying drawings, Figure 1 is a vertical section through the end-gate of a wagon or other device which supports the seeder, showing the seeder in side elevation. Fig. 2 is a plan view. Fig. 3 is a vertical section on line 3 3 of Fig. 1. Fig. 4 is a detail of the friction wheel and pinion, said parts being in section. Fig. 5 is a partial sectional view showing the friction-pinion, a part of the fan, and the supporting-shaft therefor. Fig. 6 is a perspective view of the feeding device in the hopper. Fig. 7 is a plan view of the base-plate, showing the regulating-shutters for adjusting the size of the seed-passages; and Fig. 8 is an under side view of the hopper, showing the cut-off shutter.

Referring to the drawings, 10 indicates the end-gate of a wagon or other suitable support to which the parts of the seeder are secured.

11 indicates the hopper or seedbox, and 12 a supporting base-plate therefor, which is secured to the end-gate 10 in any suitable manner.

13 indicates the bottom plate of the hopper, which rests on the base-plate 12 and is secured thereto.

14 15 indicate passages or tubes provided in the base-plate 12, preferably near the center thereof, for the passage of seed through said base-plate. The bottom 13 of the hopper is provided with a central passage which extends over the passages 14 15, so that seed may pass from the hopper to said passages 14 15.

16 indicates a cut-off shutter consisting of a flat plate which is mounted on a pivot near one edge of the bottom 13 of the hopper, being secured to the under side thereof, as shown in Fig. 3. The shutter 16 extends across the opening in the bottom of the hopper and is provided with openings 18 19, which

are adapted to be moved into and out of register with the passages 14 15. The cut-off shutter 16 is provided with a handle or lever 20, which projects laterally, as shown in Figs. 3 and 8, so that the shutter may be swung to move its openings 18 19 to one side or the other. As shown in Fig. 8, the opening in the bottom 13 of the hopper is so arranged that when the shutter 16 moves out of register with the passages 14 15 said openings 18 19 move to a greater or less extent over the bottom, and their area is correspondingly reduced. In order to hold the cut-off shutter in its different positions, it is provided at one edge with a lug 21, as shown in Fig. 8, which lug is adapted to be engaged by a spring 22, secured between stops 23 24, carried at the bottom of the hopper. The spring 22 is provided with lugs or ridges 25 at intervals which by their engagement with the lug 21 serve to hold the shutter 16 in position. Furthermore, the frictional engagement of the ridges 25 with the adjacent edge of the shutter 16 acts to prevent the shutter from moving too easily and tends to prevent automatic displacement thereof.

26 27 indicate auxiliary shutters, which are pivoted upon the upper surface of the base-plate 12, as shown at 28 in Fig. 7. Said shutters are adapted to move over the passages 14 15 to regulate the operative area of said passages. The shutters 26 27 are provided with projecting ends 29 30, which extend below segmental slots 31 32, respectively, in the base-plate 12, as shown in Fig. 2. The ends 29 30 are provided with thumb-screws 33, by which the shutters 26 27 may be locked in their different positions of adjustment.

34 indicates a feeding device arranged in the hopper 11 and mounted on a horizontal shaft 35, the ends of which are journaled at opposite sides of the hopper, as shown in Fig. 3. The feeding device 34 is adapted to be rotated to discharge the seed through the openings 18 19 in the usual way.

36 indicates the distributing-fan, which, as shown in Fig. 3, is mounted on a vertical shaft 37. The lower end of the shaft 37 is stepped in a bearing 38, formed in a bracket 39, which is secured to the end-gate 10, as shown in Fig. 1, the upper end of said shaft being fitted in a suitable bearing 40 in the base-plate 12, and said shaft is longitudinally movable in its bearings, as shown in Fig. 3. The distributing-fan 36 may be of any approved construction, but is preferably constructed as shown in my former patent, above referred to. In the construction shown it is fixedly mounted upon the shaft 37 and is connected at its under side with a conical pinion or friction-wheel 41, the greater diameter of which is uppermost. The pinion 41 is fixedly secured to the distributing-fan 36 or to the shaft 37 and rotates and also moves vertically therewith.

42 indicates a stop which is secured on the shaft 37 below the pinion 41 to prevent down-

ward movement of the pinion 41 independently of the shaft.

In its broadest aspect my invention is not limited to securing the distributing-fan and friction-pinion 41 fixedly upon the shaft 37 and making said shaft longitudinally movable in its bearings, since, if desired, the shaft 37 may be arranged so as not to move longitudinally, the pinion and fan then being loose on the shaft and connecting together, either directly or indirectly. It is essential, however, that the distributing-fan and pinion be free to move vertically as the machine operates, so that the parts of the apparatus are held in operative position by gravity, as will be hereinafter fully explained. The pinion 41 is preferably provided with a covering 43, of leather or other material, by which a suitable friction-surface is secured.

44 indicates a horizontal drive-shaft, one end of which is mounted in a suitable bearing 45, carried by the bracket 39, its other end being suitably supported from the end-gate. The shaft 44 is arranged to be driven in any suitable manner from one of the wagon-wheels, as described in my former patent, above referred to.

46 indicates a friction drive-wheel, which is mounted upon the shaft 44 and is keyed or otherwise fixedly secured thereto. The drive-wheel 46 is provided with a beveled face 47, which is adapted to engage the beveled surface of the pinion 41, as shown in Fig. 3, so that by rotating the drive-wheel 46 the pinion 41 and distributing-fan 36 are rotated.

The operation is as follows: The hopper being supplied with grain, the rotation of the feeding device 34 causes the grain to pass down through openings 18 19 and passages 14 15 to the distributing-fan 36. It will be understood that the feeding device 34 is driven by suitable connections from one of the wagon-wheels, preferably in the manner illustrated in my said former patent. The movement of the wagon also effects the rotation of the shaft 44 and friction drive-wheel 46. The weight of the distributing-fan and pinion 41 causes said pinion 41 to engage the beveled surface 47 of the drive-wheel 46 with sufficient pressure to cause said drive-wheel through friction to rotate said pinion 41 and with it the distributing-fan. The distributing-fan and pinion 41 being, however, free to move vertically, the pinion 41 readily accommodates itself to inequalities either in its own surface or in the friction-surface of the drive-wheel 46, so that a uniform rotation is at all times secured. In practice it is extremely difficult to provide a drive-wheel such as that illustrated with a perfectly-true driving-surface; but that is not objectionable in view of the fact that such inequalities are automatically compensated for, as above described. By driving the distributing-fan through friction drive mechanism, as above described, the noise which is invariably caused by the use of gearing is avoided.

I have shown the friction-pinion connected directly to the distributing-fan; but my invention is not restricted to such direct connection of said parts, as intermediate mechanism may be employed for that purpose.

That which I claim as my invention, and desire to secure by Letters Patent, is—

1. The combination of a distributing-fan arranged to rotate about a vertical axis, a pinion connected with said fan for rotating the same, and a drive-wheel arranged to rotate about a horizontal axis and adapted to engage said pinion for rotating the same, said pinion being vertically movable, substantially as described.

2. The combination of a distributing-fan arranged to rotate about a vertical axis, a pinion connected with said fan for rotating the same, and a drive-wheel arranged to rotate about a horizontal axis and adapted to engage said pinion for rotating the same, said pinion being vertically movable, the operating-faces of said pinion and drive-wheel being inclined, substantially as described.

3. In a broadcast seeding device, the combination of a hopper, a distributing-fan beneath said hopper and arranged to rotate about a vertical axis, a friction-pinion connected with said distributing-fan, and a friction drive-wheel arranged to rotate about a horizontal axis and adapted to frictionally engage said pinion, said pinion being vertically movable, substantially as and for the purpose specified.

4. In a broadcast seeding device, the combination of a hopper, a distributing-fan beneath said hopper and arranged to rotate about a vertical axis, a friction-pinion connected with said distributing-fan, and a friction drive-wheel arranged to rotate about a horizontal axis and adapted to frictionally engage said pinion, said pinion being vertically movable, the operating-surfaces of said pinion and drive-wheel being inclined, substantially as and for the purpose specified.

5. In a broadcast seeding device, the combination of a hopper, a distributing-fan beneath said hopper, mounted upon a vertical shaft, a pinion mounted upon said shaft, said

pinion and fan being vertically movable, a horizontal drive-shaft, and a drive-wheel mounted on and fixedly secured to said horizontal shaft, said drive-wheel being adapted to engage said pinion for rotating said pinion and distributing-fan, substantially as described.

6. In a broadcast seeding device, the combination of a hopper, a distributing-fan beneath said hopper mounted upon a vertical shaft, a friction-pinion mounted upon said shaft, said friction-pinion and fan being vertically movable, a horizontal drive-shaft, and a friction drive-wheel mounted on and fixedly secured to said horizontal shaft, said friction drive-wheel being adapted to engage said pinion for rotating said friction-pinion and distributing-fan, substantially as described.

7. In a broadcast seeding device, the combination of a hopper having an opening for the passage of seed, a shutter pivotally supported and adapted to move across said opening to vary the area thereof, and a spring for holding such shutter in different positions of adjustment, substantially as described.

8. In a broadcast seeding device, the combination of a hopper having an opening for the passage of seed, a shutter pivotally supported and adapted to move across said opening to vary the area thereof, and a spring for holding such shutter in different positions of adjustment, said spring having projecting means adapted to engage said shutter to hold it in position, substantially as described.

9. In a broadcast seeding device, the combination of a hopper having an opening for the passage of seed, a shutter pivotally supported and adapted to move across said opening to vary the area thereof, a spring for holding such shutter in different positions of adjustment, said spring having projecting means adapted to engage said shutter to hold it in position, and a lug projecting from said shutter and adapted to engage said spring, substantially as described.

CHRISTIAN N. E. GRAY.

Witnesses:

J. FRANK DAVIS,
EDWARD A. WALTZ.