

*G. F. Morse,*  
*Balanced Valve.*

*No. 107,945.*

*Patented Oct. 4, 1870.*

*Fig. 3.*

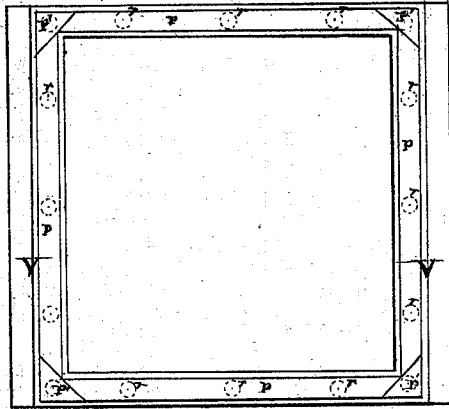

*Fig. 2.*

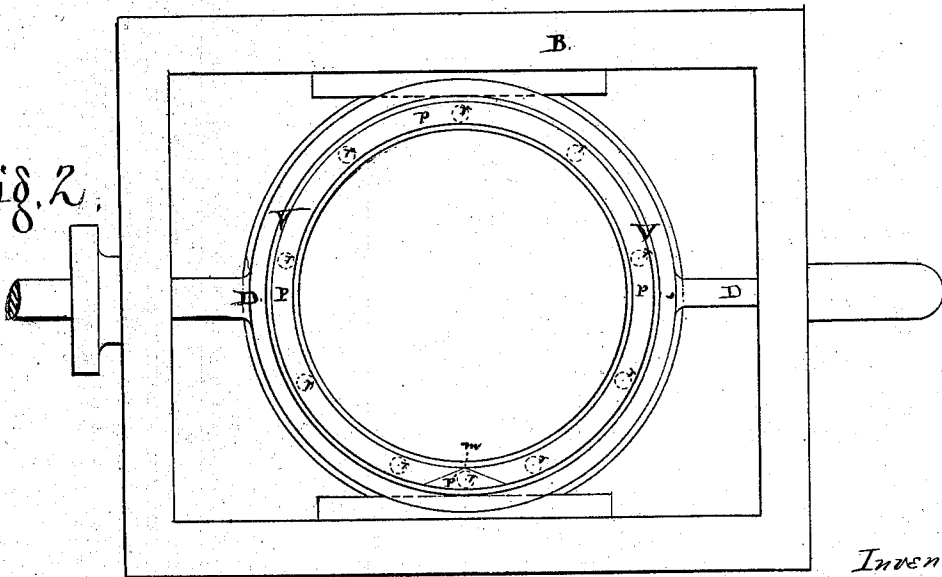

*Fig. 1.*

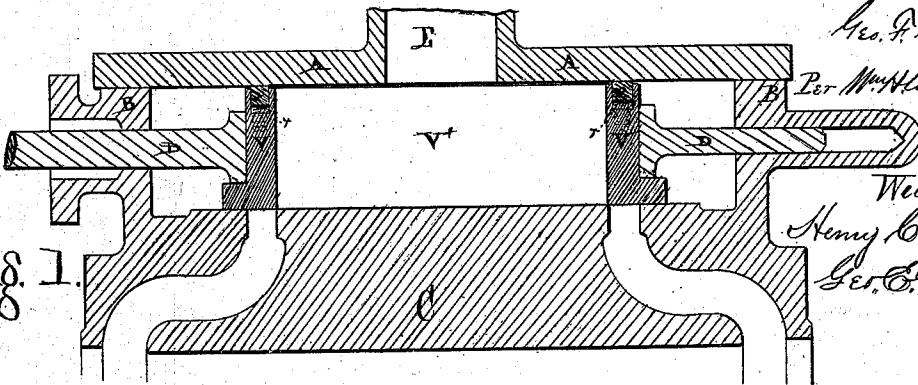

*Inventor:*

*G. F. Morse*

*Per Wm. H. Clifford, Atty*

*Witnesses:*

*Henry C. Houston*

*Geo. E. Bird*

# UNITED STATES PATENT OFFICE:

GEORGE F. MORSE, OF PORTLAND, MAINE.

## IMPROVEMENT IN BALANCED SLIDE-VALVES.

Specification forming part of Letters Patent No. 107,945, dated October 4, 1870.

*To all whom it may concern:*

Be it known that I, GEORGE FREDERIC MORSE, of Portland, in the county of Cumberland and State of Maine, have invented a new and useful Improvement in Balanced Slide-Valves for Steam-Engines; and I do hereby declare the following to be a full, clear, and exact description thereof, which will enable others to make and use my invention, reference being had to the accompanying drawings, forming part of this specification, in which—

Figure 1 represents a section of the balanced slide-valve placed in position in the steam-chest. Fig. 2 represents a plan of the balanced slide-valve of circular form. Fig. 3 represents a plan of the balanced slide-valve of rectangular form.

In the following description I have set forth the nature and principles of said improvement, by which my invention may be distinguished from others of a similar class.

The valve is shown as a simple rectangular or circular box having sides, but neither top nor bottom. These sides are to be perpendicular, or nearly so, the bottom edges bearing on the valve-seat of the cylinder and the top edges reaching very nearly to the cover of the steam-chest. On and throughout the entire length of the top edges of these sides is fitted a packing-ring or packing-strips, to be pressed against the steam-chest cover by pressure of steam in the chest, thus preventing steam from passing over into the space inclosed by the sides of the valve. The amount of lap required on the valve should be added as flanges at the bottom edge, bearing on the valve-seat. The steam is exhausted from the cylinder into the space inclosed by the walls or sides of the valve, and can be passed from thence through the valve-seat, as ordinarily done, or through the steam-chest cover, as shown in Fig. 1 at E.

The packing-ring of the circular form of valve is allowed to contract, when acted upon by external pressure of steam, by cutting, as shown at *m* in Fig. 2, the wedge-piece *p'* filling up the space and allowing at the same time the contraction of the ring, and adjusting itself

to suit such contraction, thus making a tight joint at the point of cutting. It is only by allowing such contraction that the joint between the inner side of the ring and the inner side of the channel in the edge of the valve can be kept tight and steam prevented from passing by it into the space inclosed by the sides or walls of the valve.

In the rectangular form of valve, as shown in Fig. 3, the packing-strips *p* are pressed by external pressure of steam against the inner surface of the channel holding said strips, thereby making a tight joint at those parts. The joints between the strips, at the corners of the valve, are kept tight by the pieces *p'*, which bear against the ends of the strips, adjusting themselves according to the position of the strips, and allowing for variation in the length of the strips from expansion by heat or other cause. It is by the use of these corner pieces, *p'*, in the rectangular form of valve that the packing-strips are rendered effective in making a tight joint between the top edges of the valve and the steam-chest cover, thereby preventing the steam from passing over into the space inclosed by the sides or walls of the valve.

The packing-ring in the circular form of valve and the packing-strips in the rectangular form of valve are constantly pressed up against the steam-chest cover by springs placed underneath the ring or strips.

The valve constructed as above described can receive but little pressure from steam in the steam-chest, since the only portions subject to pressure being the narrow space outside the packing ring or strips on the top edge of the valve and the amount of surface on the flanges at the bottom edge for the required lap of the valve. This small amount of pressure is desirable to keep the valve on its seat, and the valve is practically a balanced slide-valve.

In the drawings, A shows the steam-chest cover; B, the walls of the steam-chest; C, the valve-seat; D, the arm of the valve; E, the aperture through the steam-chest cover. V shows the valve; V', the space within the valve; *p*, the ring or strip packing; *p'*, the

wedge or corner pieces;  $m$ , the cutting of the ring-packing.  $r$   $r$  show the springs underneath the packing.

What I claim as my invention, and desire to secure by Letters Patent, is—

1. The packing-wedge  $p'$  in the packing-ring  $p$ , where the packing-ring is subjected to external pressure, or is contracted in order to make the joint tight for which it is used.

2. The corner pieces,  $p'$ , for making a tight joint at the ends of the packing-strips, where said strips are required to be placed in a rectangular valve or in an angular position.

GEORGE FRED. MORSE.

Witnesses:

WM. HENRY CLIFFORD,

HENRY C. HOUSTON.