

D. Rice.

Wash-Board.

N^o 6,835

Patented Oct. 30, 1849.

Fig 1.

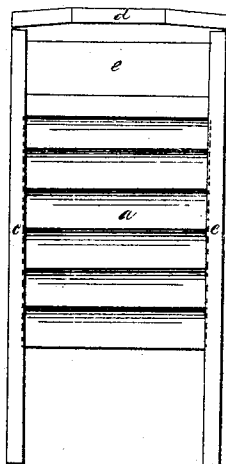

Fig 2.

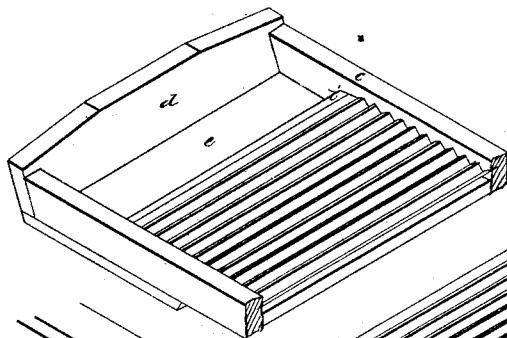
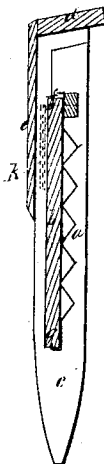
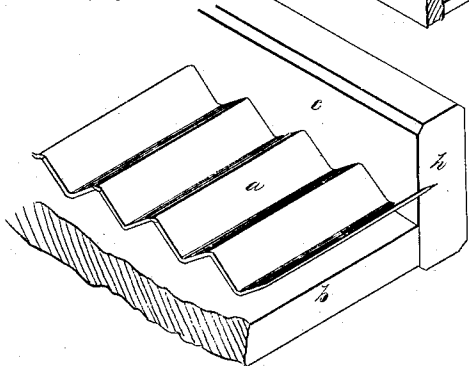

Fig 3.

Fig 4.



Inventor.
Orrin Rice

UNITED STATES PATENT OFFICE.

ORRIN RICE, OF CINCINNATI, OHIO.

IMPROVEMENT IN WASH-BOARDS.

Specification forming part of Letters Patent No. 6,835, dated October 30, 1849.

To all whom it may concern:

Be it known that I, ORRIN RICE, of Cincinnati, Hamilton county, Ohio, have invented new and useful Improvements in the Manufacture of Metallic Wash - Boards, called "Rice's Pressed Wash-Board;" and I do hereby declare the following to be a full, clear, and exact description of the manner of making and using the same, reference being had to the annexed drawings, making part of this specification, in which—

Figure 1 is a front view; Fig. 2, a longitudinal section; Fig. 3, an isometric view; and Fig. 4, on an enlarged scale, showing the sharpened zinc where it penetrates the wood, the same being a broken sectional view.

The nature of my invention consists in the mode of manufacturing wash-boards out of metal and wood combined by so preparing the sheet of zinc or other metal that by sharpening two parallel edges and crimping the sheet from one of these edges to the other I am enabled by using pressure to incise and fasten to the wooden sides the sheet thus prepared.

Wash-boards first consisted of a simple piece of plank. To this succeeded a fluted plank. Both of these were destructive to the clothes and soon worn out. It was then found that zinc or other metal would suit the object in view, and sheets of metal were crimped and laid in rabbets made in sides of wood and fastened therein by being tacked to strips of wood running from one side to the other. To this succeeded a similar wash-board with a plank body, because it was found that the zinc gave way under the pressure exerted in washing and was soon rendered useless. Varieties in the form of the crimp were also projected. After this a groove was made in the sides and of such width as to accommodate various crimps to suit the fancy of purchasers. This board was found to have all the disadvantages of the one with rabbeted sides—viz., collecting dirt along the sides and weakening them by grooves or mortises, so that by the dirt and continued wet being swollen, rotted, and burst apart, they soon broke and rendered the whole contrivance abortive. Moreover, the wood-work being expensive in proportion to the article to be furnished the market a narrow groove only was made. This rendered it necessary to flatten or round or diminish the

pitch of the crimp, thereby depriving them of any utility.

The only improvement so far attained in the manufacture of wash-boards was sawing a slit across the body-board in which to lay the edges of the zinc in the line of the crimp at top and bottom.

To obviate in some measure the objections above of dirt, swelling and bursting apart, and early breakage, another wash-board came into market. This wash-board being made with a mortise in its sides or legs scribed to the crimp on one side of the mortise and leaving room for the insertion of the body-board between the notches cut out for the zinc and the other side of the mortise, was still found as objectionable and obnoxious to the requirements of the case as any of the wash-boards previously manufactured. Add to all this that prime cost in the manufacture of these household and every-day articles made them in the first place too high priced, and their defects and destructibility, both in themselves and with regard to the clothes washed thereon, caused them, in the second place, to be rejected by the great mass of the people. To invent anything obviating all these difficulties was, therefore, the great object of their manufacturers. The field for invention was as limited as the utility of the article was great, provided the end desired was attained. In the important objects before alluded to I have succeeded, and not only theoretically, but experimentally and then practically—that is to say, those trying my wash-board will use no other. My board commands the market. It is the cheapest, best made, most enduring, and efficient of any hitherto devised, being free from dirt with ordinary care, capable of drying rapidly after being used, and so constructed with regard to the junction of the wood with the metal that I retain all the strength of the wood and use at the same time any pitch or base for the crimp in the metal that fancy, fashion, capacity for the work to be done, or other reasonable want can urge. The process by which I effect these improvements consists in taking a sheet of zinc, dividing it into strips of the width desired, and sharpening to a cutting-edge the sides that are to incise the wooden standards of the frame, and thereby attach the one to the other when they are brought properly to-

gether, so that by the application of pressure the sheet is buried to a suitable extent, not only fast and firmly into the wood, but so aptly that it forms comparatively a water-tight joint and rids the machine of the liability to swell and burst asunder; and even a slight moisture getting behind the metal from any accident or imperfection in the article is easily driven out by placing the board where the metal can become warm. The metal and wood being thus exactly and instantly adapted, fitted, and closely joined the one to the other by machinery expressly prepared for the purpose, the article can be furnished to the market at fifty per cent. less cost. This cheapness and durability can only be effected by my process.

I have tried using a knife matched to the crimp of the sheet of zinc for incising the standards; but this renders it necessary to fit the zinc to the incision in the side afterward. I have also essayed pressing the edge unsharpened into the wood; but the former operation is tedious, requiring an exactitude to be arrived at utterly unattainable in the manufacture, necessarily of the cheapest, of an article so commonly used, and the latter is inadequate (on account of the mashing up of the metal and the bruising of the wood) to attain the result so universally sequent upon the process of pressing the parts together—viz., the sharpened metal and the wood—and nailing the sides to the back board while the whole are under pressure. When the sheet is not sharpened, the angle of the crimp must be very obtuse or else the metal will not enter the wood at all. I have tried analogous devices, but they have all failed to accomplish the purpose. Besides this is the only process that will enable the manufacturer by using heavier metal to make the board double—that is to say, capable of being used on both sides, and that, too, with any-sized crimps desired, the attachment between the wood and metal being equally water-tight on either side.

In the annexed drawings, *a* is the sheet of metal crimped to the desired pitch after having been reduced to a cutting-edge, as seen at *h*, Figs. 3 and 4.

b is the body-board.

c are the "sides," "standards," or "legs," as they are indifferently termed.

The metallic sheet can either be turned over the edge of the body-board and sunk in the wood, as seen at *f* and *g*, Fig. 2, or let into a groove cut by a saw into the top and bottom (front face) of the same board, as seen at *i*, Fig. 3. These upper and lower edges of the sheet metal may also be pressed into the body-board, the same being reduced to a cutting-edge for that purpose.

d and *e* are the top and back boards, hold the loop, return the water to the tub through the channel *k*, and maintain the sides and body-board firmly in position.

At *h*, Figs. 3 and 6, is distinctly seen the cutting-edge (of greatest importance) sunk suitably deep into the legs or sides *c* by means of pressure, thereby producing a new and useful result hitherto unattained. The body-board and sides are further secured together by nails driven in by machinery or in the ordinary way. A batten at *f* and another at *g* may be substituted for a body-board, provided heavier metal is used, and in that case both sides of the metal can be used. There are several ways, however, of making the wash-board double, provided my invention is applied for the purpose of attaching the metal to the wood.

Having thus fully described the nature and effect of my invention, I wish it to be distinctly understood that I do not claim any of the several parts composing a wash-board made of sheet metal and wood; but

That which I do claim as my new and useful improvement in the mode of manufacturing such wash-boards, and for which I ask Letters Patent, is—

Incising with the edges of the sheet metal (prepared and crimped as described) the legs, or the legs and body-board, by the suitable application of pressure thereto, thereby fitting and attaching the one to the other at one operation and with a comparatively water-tight joint.

ORRIN RICE.

Attest:

THOS. G. CLINTON,
GEO. H. KNIGHT.