

(19) World Intellectual Property Organization
International Bureau



(43) International Publication Date
5 January 2012 (05.01.2012)

(10) International Publication Number
WO 2012/000099 A1

- (51) **International Patent Classification:**
A63C 19/04 (2006.01) EOIC 13/10 (2006.01)
- (21) **International Application Number:**
PCT/CA2011/000771
- (22) **International Filing Date:**
30 June 2011 (30.06.2011)
- (25) **Filing Language:** English
- (26) **Publication Language:** English
- (30) **Priority Data:**
61/359,918 30 June 2010 (30.06.2010) US
- (71) **Applicant (for all designated States except US):** ADVANTAGE COCHRANE SPORT INC. [CA/CA]; 121 Gaston Dumoulin, Blainville, Quebec J7C 6B4 (CA).
- (72) **Inventor; and**
- (73) **Inventor/Applicant (for US only):** VACHON, Frederic [CA/CA]; 767 Etienne Lavoie, Ste-Dorothee, Quebec H7X 0A2 (CA).
- (74) **Agent:** BENOÎT & CÔTÉ, ASSOCIÉS INC.; 1001 De Maisonneuve Blvd West, Suite 210, Montreal, Quebec H3A 3C8 (CA).

- (81) **Designated States (unless otherwise indicated, for every kind of national protection available):** AE, AG, AL, AM, AO, AT, AU, AZ, BA, BB, BG, BH, BR, BW, BY, BZ, CA, CH, CL, CN, CO, CR, CU, CZ, DE, DK, DM, DO, DZ, EC, EE, EG, ES, FI, GB, GD, GE, GH, GM, GT, HN, HR, HU, ID, IL, IN, IS, JP, KE, KG, KM, KN, KP, KR, KZ, LA, LC, LK, LR, LS, LT, LU, LY, MA, MD, ME, MG, MK, MN, MW, MX, MY, MZ, NA, NG, NI, NO, NZ, OM, PE, PG, PH, PL, PT, RO, RS, RU, SC, SD, SE, SG, SK, SL, SM, ST, SV, SY, TH, TJ, TM, TN, TR, TT, TZ, UA, UG, US, UZ, VC, VN, ZA, ZM, ZW.
- (84) **Designated States (unless otherwise indicated, for every kind of regional protection available):** ARIPO (BW, GH, GM, KE, LR, LS, MW, MZ, NA, SD, SL, SZ, TZ, UG, ZM, ZW), Eurasian (AM, AZ, BY, KG, KZ, MD, RU, TJ, TM), European (AL, AT, BE, BG, CH, CY, CZ, DE, DK, EE, ES, FI, FR, GB, GR, HR, HU, IE, IS, IT, LT, LU, LV, MC, MK, MT, NL, NO, PL, PT, RO, RS, SE, SI, SK, SM, TR), OAPI (BF, BJ, CF, CG, CI, CM, GA, GN, GQ, GW, ML, MR, NE, SN, TD, TG).

Published:

— with international search report (Art. 21(3))

(54) **Title:** PADDING LAYER FOR MULTI-LAYERED SPORTS PLAYING FIELD

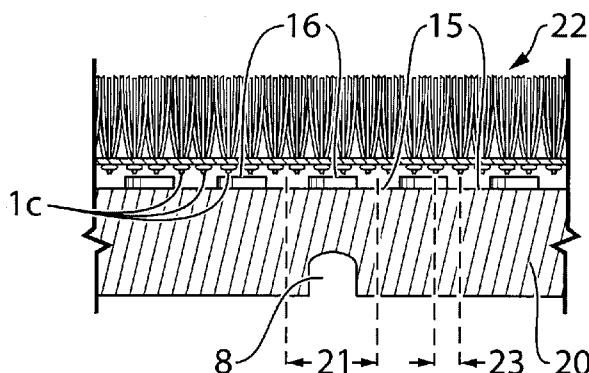

FIG. 2c

(57) **Abstract:** The present document describes a padding layer for a multi-layered sports playing field. Various improvements are proposed for enhancing athlete's safety, surface hardness, water drainage, heat management, ease of assembly / installation, durability / longevity, uniformity, resistance to change in weather according to seasons, and stability. The improvements include: matching (multiple-wise) of spacing between rows of backstitches of the top layer and the drainage channels on top surface of the padding layer; a slit in the external tab portion of the padding layer panel, a slit near the lateral part of the tab or blank portion providing a hinging effect thereto, and/or protrusions at various positions on the tab or blank portions to account for change in size of the padding layer panel; drainage holes within the drainage channels; and various configurations of drainage channels on the bottom surface of the padding layer to improve evacuation of water toward the sides of the playing surface.



WO 2012/000099 A1

PADDING LAYER FOR MULTI-LAYERED SPORTS PLAYING FIELD**CROSS-REFERENCE TO RELATED APPLICATIONS**

[0001] This application claims priority from US provisional patent application no. 61/359,918 filed on June 30, 2010.

BACKGROUND**(a) Field**

[0002] The subject matter disclosed generally relates to playing fields and more particularly to artificial sports playing fields.

(b) Related Prior Art

[0003] Present day sports playing fields are often made of a mix of natural and synthetic / artificial material. A base layer of dirt, gravel, sand or other suitable material is sometimes provided. An artificial padding layer may then be installed on top of which a layer of artificial grass is laid. The artificial grass construction is very similar to most types of industrially-made carpets and can be filled or not with material like SBR, EPDM, TPE, coated sand, sand or other infill material.

[0004] The design consideration for sports playing fields include: athlete's safety, surface hardness, water drainage, heat management, ease of assembly / installation, durability / longevity, uniformity, resistance to change in weather according to seasons, stability, etc.

[0005] The playing field described herein was developed keeping all such factors in mind.

SUMMARY

[0006] There is described herein a padding layer for a multi-layered sports playing field. Various improvements are proposed for enhancing athlete's safety, surface hardness, water drainage, heat management, ease of assembly / installation, durability / longevity, uniformity, resistance to change in weather according to seasons, and stability. The improvements include: matching (multiple-wise) of spacing between rows of backstitches of the top layer and the drainage channels on top surface of the padding layer; a slit in the external tab portion of the padding layer panel, a slit near the lateral part

of the tab or blank portion providing a hinging effect thereto, and/or protrusions at various positions on the tab or blank portions to account for change in size of the padding layer panel; drainage holes within the drainage channels; and various configurations of drainage channels on the bottom surface of the padding layer to improve evacuation of water toward the sides of the playing surface.

[0007] According to an embodiment, there is provided a padding layer panel for assembly with other substantially identical padding layer panels for forming a padding layer for installation over a surface and under a carpet-like top layer having a series of regularly spaced apart parallel rows of backstitches separated by a backstitch distance. The padding layer panel comprises: a top surface comprising top channels which are equally spaced and parallel, each one of the top channels having a center, wherein a distance between centers of adjacent ones of the top channels is defined as a channel distance, wherein the channel distance is a multiple of the backstitch distance, and wherein each one of the top channels is for receiving the same number of rows of backstitches; and two opposite edges, wherein at least a portion of the top channels extend between one of the two opposite edges to the other one of the two opposite edges.

[0008] According to another embodiment, the at least a portion of the top channels are perpendicular to both opposite edges and extend from one of the two opposite edges to the other one of the two opposite edges.

[0009] According to another embodiment, the padding layer panel further comprises a bottom surface comprising main drainage channels which are equally spaced and parallel, the main drainage channels extending in a direction of a slope of the surface thereby facilitating fluid evacuation via the main drainage channels.

[0010] According to another embodiment, the padding layer panel further comprises openings from the at least some of the top channels to at least some of the main drainage channels.

[0011] According to another embodiment, the openings from the top channels to the main drainage channels are straight and circular.

[0012] According to another embodiment, the diameter of the openings is in the range from about 0.250" to about 0.500".

[0013] According to another embodiment, the bottom surface further comprises secondary drainage channels extending non-perpendicularly between the main drainage channels.

[0014] According to another embodiment, the secondary drainage channels make a 30 to 65 degree angle with the main drainage channels.

[0015] According to another embodiment, the dimensions of the main drainage channels and the secondary drainage channels comprise a depth and a width wherein the depth and the width are in the range from about 0.25 cm to about 2.0 cm.

[0016] According to another embodiment, the channel distance is in the range from about 3/64" to about 3/4".

[0017] According to another embodiment, the thickness of the padding layer panel is normally uniform and is in the range from about 0.25" to about 6".

[0018] According to another embodiment, the padding layer panel comprises one of: an expanded polypropylene (EPP), an hybrid expanded polypropylene EPP (HEPP), a mix of an expanded polypropylene (EPP) with an expanded polyethylene (EPE) or polyethylene (PE), and a rubber material.

[0019] According to another embodiment, the padding layer comprises a closed-cell structure made with closed-cell beads.

[0020] According to another embodiment, the padding layer panel further comprises interlocking tab (male) and blank (female) portions, the tab portions having a straight external edge and a protrusion extending from the straight external edge to ensure a minimal spacing between two adjacent padding layer panels, the protrusion thereby absorbing expansion of the padding layer panel.

[0021] According to another embodiment, a height and a width of the protrusion is in the range from about 0.125" to about 0.500".

[0022] According to another embodiment, the padding layer panel further comprises comprising interlocking tab (male) and blank (female) portions, the tab portions having a lateral edge and a protrusion extending from the lateral edge to ensure a minimal spacing between two adjacent padding layer panels, the protrusion thereby absorbing contraction of the padding layer panel.

[0023] According to another embodiment, the padding layer panel further comprises interlocking tab (male) and blank (female) portions, the tab portions having a straight external edge comprising a slit to account for expansion of the padding layer panel.

[0024] According to another embodiment, the padding layer panel further comprises interlocking tab (male) and blank (female) portions, the tab portions having a straight external edge and a lateral edge, the straight external edge comprising a slit in an area near the lateral edge to form a hinged portion capable of absorbing contraction of the padding layer panel.

[0025] According to an embodiment, there is provided a multi-layered sports playing field comprising: a carpet-like top layer having a series of regularly spaced apart parallel rows of backstitches separated by a backstitch distance; and a padding layer for installation under the carpet-like top layer. The padding layer comprises a top surface comprising top channels which are equally spaced and parallel, each one of the top channels having a center, wherein a distance between centers of adjacent ones of the top channels is defined as a channel distance, wherein the channel distance is a multiple of the backstitch distance, and wherein each one of the top channels is for receiving the same number of rows of backstitches.

[0026] According to an embodiment, there is provided a padding layer for installation under a carpet-like top layer having a series of regularly spaced apart parallel rows of backstitches separated by a backstitch distance. The padding layer comprises a top surface comprising top channels which are

equally spaced and parallel, each one of the top channels having a center, wherein a distance between centers of adjacent ones of the top channels is defined as a channel distance, wherein the channel distance is a multiple of the backstitch distance, and wherein each one of the top channels is for receiving the same number of rows of backstitches.

[0027] According to an embodiment, there is provided a padding layer for a multi-layered sports playing field, the padding layer for installation under a carpet-like top layer having a series of regularly spaced apart parallel rows of backstitches separated by a given distance, the padding layer comprising: a top surface comprising regularly spaced apart parallel top drainage channels separated by a given distance, wherein the given distance separating the top drainage channels is a multiple of the given distance separating the rows of backstitches whereby at least one of the rows of backstitches will always fall in each of the channels.

[0028] According to another embodiment, there is provided a padding layer panel for use in forming a padding layer for a multi-layered sports playing field, the padding layer panel comprising: interlocking tab (male) and blank (female) portions, the tab portions having a straight external edge comprising a slit to account for expansion of the at least one of the tab portions.

[0029] According to another embodiment, there is provided a padding layer panel for use in forming a padding layer for a multi-layered sports playing field, the padding layer panel comprising: interlocking tab (male) and blank (female) portions, the tab portions having a straight external edge and a protrusion extending from the straight external edge to ensure a minimal spacing between two adjacent padding layer panels, the protrusion thereby absorbing the expansion of the padding layer panel.

[0030] According to another embodiment, there is provided a padding layer panel for use in forming a padding layer for a multi-layered sports playing field, the padding layer panel comprising: interlocking tab (male) and blank (female) portions, the tab portions having a lateral edge and a

protrusion extending from the lateral edge to ensure a minimal spacing between two adjacent padding layer panels, the protrusion thereby absorbing the contraction of the padding layer panel.

[0031] According to another embodiment, there is provided a padding layer panel for use in forming a padding layer for a multi-layered sports playing field, the padding layer panel comprising: interlocking tab (male) and blank (female) portions, the tab portions having a straight external edge and a lateral edge, the straight external edge comprising a slit in an area near the lateral edge to form a hinged portion capable of absorbing the contraction of the padding layer panel.

[0032] According to another embodiment, there is provided a padding layer for a multi-layered sports playing field, the padding layer comprising: a top surface comprising top drainage channels; a bottom surface comprising bottom drainage channels; and openings from the top drainage channels to the bottom drainage channels.

[0033] According to another embodiment, there is provided a padding layer for a multi-layered sports playing field having sides and a middle portion therebetween, the sides of the playing field being lower than the middle portion to ensure proper water drainage, the padding layer for installation under a carpet-like top layer having a series of regularly spaced apart parallel backstitches separated by a given distance, the padding layer comprising: a bottom surface comprising regularly spaced apart parallel main drainage channels, the main drainage channels extending from side-to-side of the playing field.

[0034] According to another embodiment, there is provided a padding layer disclosed above wherein the bottom surface further comprises secondary drainage channels extending non-perpendicularly between the main drainage channels.

[0035] Features and advantages of the subject matter hereof will become more apparent in light of the following detailed description of selected embodiments, as illustrated in the accompanying figures. As will be realized,

the subject matter disclosed and claimed is capable of modifications in various respects, all without departing from the scope of the claims. Accordingly, the drawings and the description are to be regarded as illustrative in nature, and not as restrictive and the full scope of the subject matter is set forth in the claims.

BRIEF DESCRIPTION OF THE DRAWINGS

[0036] Further features and advantages of the present disclosure will become apparent from the following detailed description, taken in combination with the appended drawings, in which:

[0037] Fig. 1 is a partial cutout elevation view illustrating the padding layer according to an embodiment of the present disclosure;

[0038] Fig. 1a is a partial cutout elevation view of a portion of Fig. 1;

[0039] Figs. 2a, 2b, and 2c are a partial cutout elevation view illustrating the padding layer according to embodiments of the present disclosure on which is laid a top layer made of substantially artificial material simulating a natural playing surface such as grass;

[0040] Fig. 3 is a top plan view of one interlocking padding layer panel according to an embodiment of which many are joined together to make the padding layer;

[0041] Fig. 3a is a close-up view of a protrusion on the side of the interlocking padding layer panel of Fig. 3;

[0042] Fig. 4 is a bottom plan view of the one interlocking padding layer panel according to an embodiment; and

[0043] Fig. 5 is a schematic view of a playing field view from above according to an embodiment of the disclosure.

[0044] It will be noted that throughout the appended drawings, like features are identified by like reference numerals.

DETAILED DESCRIPTION

[0045] Referring now to the drawings, and more particularly to Figs. 1, 1a, 2a, 2b, 2b, and 5, an embodiment of a padding layer **20** is shown. Padding layer **20** is adapted for a multi-layered sports playing field **30**. The padding layer **20** is for installation under a carpet-like top layer **22** and over a surface (not shown) which may include a base layer (not shown) of dirt, gravel, sand or other suitable material.

[0046] The carpet-like top layer **22** has a series of regularly spaced apart (or equally spaced) parallel rows of backstitches **1a**, **1b**, **1c** separated by a backstitch distance **23**.

[0047] The padding layer **20** comprises a top surface **24** which comprises equally spaced parallel top channels **15** separated by a channel distance **21**. The channel distance **21** is the distance between centers of adjacent channels. The channel distance **21** separating the top channels **15** is a multiple of the backstitch distance **23** separating the rows of backstitches **1a**, **1b**, **1c** whereby at least one of the rows of backstitches **1a**, **1b**, **1c** will always fall in each of the top channels **15**. In fact, each one of the top channels **15** is for receiving the same number of rows of backstitches **1a**, **1b**, **1c**.

[0048] This fact that at least one of the rows of backstitches **1a**, **1b**, **1c** will always fall in each of the top channels **15** is very useful for preventing slippage of the carpet-like top layer **22** relative to the padding layer **20** in a direction perpendicular to the longitudinal direction of the row of backstitches **1a**, **1b**, **1c**.

[0049] The top channels **15** are also useful for drainage or evacuation of water from the surface of the multi-layered sports playing field **30**.

[0050] The thickness of the padding layer **20** is normally uniform and may range between 0.25" to 6". The material of the padding layer **20** can be Expanded Polypropylene (EPP). In another embodiment, the material of the padding layer **20** can be an Hybrid EPP (HEPP), which is a mix of a EPP with an expanded Polyethylene (EPE), a Polyethylene (PE), a rubber material, a

recyclable material or another suitable material to maximize the hardness-flexibility ratio. According to an embodiment, the padding layer **20** is a closed-cell structure made with closed-cell beads.

[0051] According to an embodiment, the channel distance **21** separating the top channels **15** is 3/4". In such an embodiment, the top channels **15** can accommodate a backstitch distance **23** separating the rows of backstitches **1a, 1b, 1c** of 3/4", 3/8", 3/16", etc. Of course, it is understood that if the rows of backstitches **1a, 1b, 1c** are distanced according to another standard measure, e.g., 20 mm, 10 mm, 5 mm, etc, top surface **24** will be made with a channel distance **21** separating the top channels **15** which is a multiple thereof such as 20 mm. The depth of the top channels **15** may vary between 1 mm and 4 mm. The height of a divider **16** therefore corresponds to the depth of the top channels **15**. According to an exemplary embodiment, the width of the top channels **15** is 5 to 20 mm.

[0052] As shown in Fig. 2a, for a backstitch distance **23** of 3/4", each backstitch **1a** will fall in a separate top channel **15** while no backstitches **1a** fall on a divider **16**.

[0053] As shown in Fig. 2b, for a backstitch distance **23** of 3/8", one backstitch **1b** will fall in a separate top channel **15** and one backstitch **1b** will be aligned with a divider **16**.

[0054] As shown in Fig. 2c, for a backstitch distance **23** of 3/16", two backstitches **1c** will fall in a separate top channel **15** and two backstitches **1c** will be aligned with a divider **16**.

[0055] As shown in Fig. 5, rolls of carpet-like top layer **22** are laid down on playing field **30** according to a roll direction **36**. In this embodiment, the direction **17** of rows of backstitches which correspond to the roll direction **36** extend from one side **32** to the other side **34** of the playing field **30**. The sides **32, 34** of the playing field **30** are lower than a middle portion **52** to ensure proper water drainage and evacuation.

[0056] Since most often the play of a game on such playing field **30** occurs in play direction **38**, the divider **16** (Fig. 2) will greatly interfere with

movement of the rows of backstitches **1a**, **1b**, **1c** and hence with movement of the rolls of carpet-like top layer **22** in the direction of play **38**.

[0057] Now turning to Fig. 4, according to another embodiment, the padding layer **20** comprises a bottom surface **26** which comprises regularly / equally spaced apart parallel main drainage channels **8**. The main drainage channels **8** extending from side-to-side of the playing field **30**.

[0058] According to another embodiment, the bottom surface **26** further comprises secondary drainage channels **9** extending non-perpendicularly between the main drainage channels **8**. According to an embodiment, the dimensions of the main drainage channels **8** and the secondary drainage channels **9** ranges between a depth of 0.25 cm to 2 cm and a width of 0.25 cm to 2 cm. Examples of depth and width are 0.25cm x 0.25 cm, 2.0cm x 2.0cm, 0.5cm x 0.5cm, 1.0cm x 1.0cm and 0.25 x 2 cm. The depth and width are not necessarily of equal dimension.

[0059] According to another embodiment, the secondary drainage channels **9** make a 30 to 65 degree angle with the main drainage channels **8**. According to another embodiment, the secondary drainage channels **9** make a 45 degree angle with the main drainage channels **8**. Other angles are also possible as long as water drainage is possible. The secondary drainage channels **9** are positioned at mirror angles **10** and **19** to enable drainage from the middle portion **52** to both sides **32** and **34**. The installers of the padding layer panels **40** (see Figs. 3 and 4) therefore only have to ensure that the main drainage channels **8** are installed perpendicularly to the play direction **38**.

[0060] Now referring to Figs. 3, 3a, and 4, an embodiment of a padding layer panel **40** is shown. The padding layer panel **40** is for use in forming a padding layer (see previous figures) for a multi-layered sports playing field **30** (see Fig. 5). The padding layer panel **40** comprises interlocking tab (male) **42** and blank (female) **44** portions. The tab portions **42** have a straight external edge **46** comprising a slit **2** to account for expansion of the at least one of the tab portions **42**. Expansion will occur due to an increase in temperature (hot

weather). According to an embodiment, the width of the slit **2** is between 5mm to 25mm.

[0061] According to another embodiment, the padding layer panel **40** comprises interlocking tab (male) **42** and blank (female) **44** portions. The tab portions **42** has a straight external edge **46** and a protrusion **3** extending from the straight external edge **46** to ensure a minimal spacing between two adjacent padding layer panels **40**. The protrusion **3** may thereby absorb the expansion of the padding layer panel **40**. According to an embodiment, the protrusion **3** has a height and a width in a range of about 0.125" to 0.500". According to another embodiment, the protrusion **3** has a height in a range of about 0.125" to 0.250" and a width in a range of about 0.250" to 0.500".

[0062] According to another embodiment, the padding layer panel **40** comprises interlocking tab (male) **42** and blank (female) **44** portions. The tab portions **42** have a lateral edge **48** and a protrusion **4** extending from the lateral edge **48** to ensure a minimal spacing between two adjacent padding layer panels **40**. The protrusion **4** thereby absorbing the contraction of the padding layer panel. Contraction will occur due to a decrease in temperature (cold weather). According to an embodiment, the protrusion **4** has a height in a range of 0.125" to 0.250" and a width in a range of 0.250" to 0.500".

[0063] According to another embodiment, the padding layer panel **40** comprises interlocking tab (male) **42** and blank (female) **44** portions. The tab portions **42** having a straight external edge **46** and a lateral edge **48**. The straight external edge **46** comprises a slit **6** in an area near the lateral edge **48** to form a hinged portion capable of absorbing the contraction of the padding layer panel **40**. According to an embodiment, the width of the slit **6** is between 5mm to 25mm.

[0064] According to another embodiment, the padding layer **20** could be provided in a roll form instead of a panel form. The thickness and flexibility determine the feasibility of providing the padding layer **20** in a roll or in a panel form.

[0065] Now returning to Figs. 1, 1a, 3, 4 and 5, there is shown another embodiment of a padding layer **20** for a multi-layered sports playing field **30**. The padding layer **20** comprises a top surface **24** which comprises top channels **15**. The padding layer **20** further comprises a bottom surface **26** which comprises main drainage channels **8**. The padding layer **20** further comprises openings **7** from the top channels **15** to the main drainage channels **8**. According to an embodiment, the openings are circular and their diameter ranges between 0.250" and 0.500".

[0066] According to an embodiment, the main drainage channels **8** are vertically aligned with a divider **16** to increase the rigidity of the padding layer panels **40**. To further increase the rigidity of the padding layer panels **40**, an arch or angled shaped **12** is provided at the top of the main drainage channels **8**.

[0067] While preferred embodiments have been described above and illustrated in the accompanying drawings, it will be evident to those skilled in the art that modifications may be made without departing from this disclosure. Such modifications are considered as possible variants comprised in the scope of the disclosure.

File No. P1445PC00

CLAIMS:

1. A padding layer panel for assembly with other substantially identical padding layer panels for forming a padding layer for installation over a surface and under a carpet-like top layer having a series of regularly spaced apart parallel rows of backstitches separated by a backstitch distance, the padding layer panel comprising:

a top surface comprising top channels which are equally spaced and parallel, each one of the top channels having a center, wherein a distance between centers of adjacent ones of the top channels is defined as a channel distance, wherein the channel distance is a multiple of the backstitch distance, and wherein each one of the top channels is for receiving the same number of rows of backstitches; and two opposite edges, wherein at least a portion of the top channels extend between one of the two opposite edges to the other one of the two opposite edges and at least one of the two opposite edges is adapted for attachment to one of the other substantially identical padding layer panels.

2. The padding layer panel of claim 1, wherein the at least a portion of the top channels are perpendicular to both opposite edges and extend from one of the two opposite edges to the other one of the two opposite edges.

3. The padding layer panel of claim 1, further comprising a bottom surface comprising main drainage channels which are equally spaced and parallel, the main drainage channels extending in a direction of a slope of the surface thereby facilitating fluid evacuation via the main drainage channels.

4. The padding layer panel of claim 3, further comprising openings from the at least some of the top channels to at least some of the main drainage channels.

File No. P1445PC00

5. The padding layer panel of claim 4, wherein the openings from the top channels to the main drainage channels are straight and circular.

6. The padding layer panel of claim 5, wherein the diameter of the openings is in a range from about 0.250" to about 0.500".

7. The padding layer panel of claim 3, wherein the bottom surface further comprises secondary drainage channels extending non-perpendicularly between the main drainage channels.

8. The padding layer panel of claim 7, wherein the secondary drainage channels make a 30 to 65 degree angle with the main drainage channels.

9. The padding layer panel of claim 8, wherein the dimensions of the main drainage channels and the secondary drainage channels comprise a depth and a width wherein the depth and the width are in a range from about 0.25 cm to about 2.0 cm.

10. The padding layer panel of claim 1, wherein the channel distance is in a range from about 3/64" to about 3/4".

11. The padding layer panel of claim 1, wherein the thickness of the padding layer panel is normally uniform and is in a range from about 0.25" to about 6".

12. The padding layer panel of claim 1, wherein the padding layer panel comprises one of: an expanded polypropylene (EPP), an hybrid expanded polypropylene EPP (HEPP), a mix of an expanded polypropylene (EPP) with an expanded polyethylene (EPE) or polyethylene (PE), and a rubber material.

13. The padding layer panel of claim 1, wherein the padding layer comprises a closed-cell structure made with closed-cell beads.

File No. P1445PC00

14. The padding layer panel of claim 1, further comprising interlocking tab (male) and blank (female) portions, the tab portions having a straight external edge and a protrusion extending from the straight external edge to ensure a minimal spacing between two adjacent padding layer panels, the protrusion thereby absorbing expansion of the padding layer panel.

15. The padding layer panel of claim 14, wherein a height and a width of the protrusion is in a range from about 0.125" to about 0.500".

16. The padding layer panel of claim 1, further comprising interlocking tab (male) and blank (female) portions, the tab portions having a lateral edge and a protrusion extending from the lateral edge to ensure a minimal spacing between two adjacent padding layer panels, the protrusion thereby absorbing contraction of the padding layer panel.

17. The padding layer panel of claim 1, further comprising interlocking tab (male) and blank (female) portions, the tab portions having a straight external edge comprising a slit to account for expansion of the padding layer panel.

18. The padding layer panel of claim 1, further comprising interlocking tab (male) and blank (female) portions, the tab portions having a straight external edge and a lateral edge, the straight external edge comprising a slit in an area near the lateral edge to form a hinged portion capable of absorbing contraction of the padding layer panel.

19. A multi-layered sports playing field comprising:
a carpet-like top layer having a series of regularly spaced apart parallel rows of backstitches separated by a backstitch distance; and
a padding layer for installation under the carpet-like top layer, the padding layer comprising:

File No. P1445PC00

a top surface comprising top channels which are equally spaced and parallel, each one of the top channels having a center, wherein a distance between centers of adjacent ones of the top channels is defined as a channel distance, wherein the channel distance is a multiple of the backstitch distance, and wherein each one of the top channels is for receiving the same number of rows of backstitches.

20. A padding layer for installation under a carpet-like top layer having a series of regularly spaced apart parallel rows of backstitches separated by a backstitch distance, the padding layer comprising:

a top surface comprising top channels which are equally spaced and parallel, each one of the top channels having a center, wherein a distance between centers of adjacent ones of the top channels is defined as a channel distance, wherein the channel distance is a multiple of the backstitch distance, and wherein each one of the top channels is for receiving the same number of rows of backstitches.

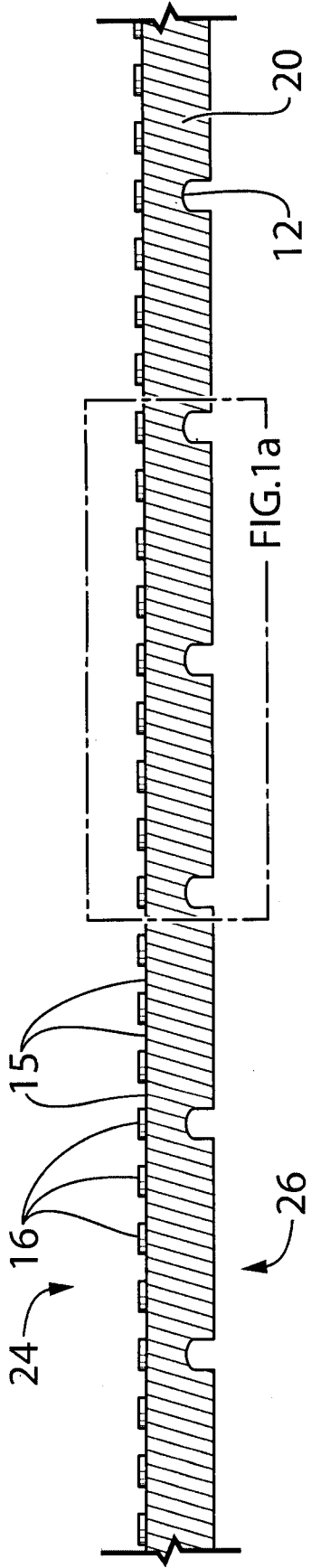

FIG. 1

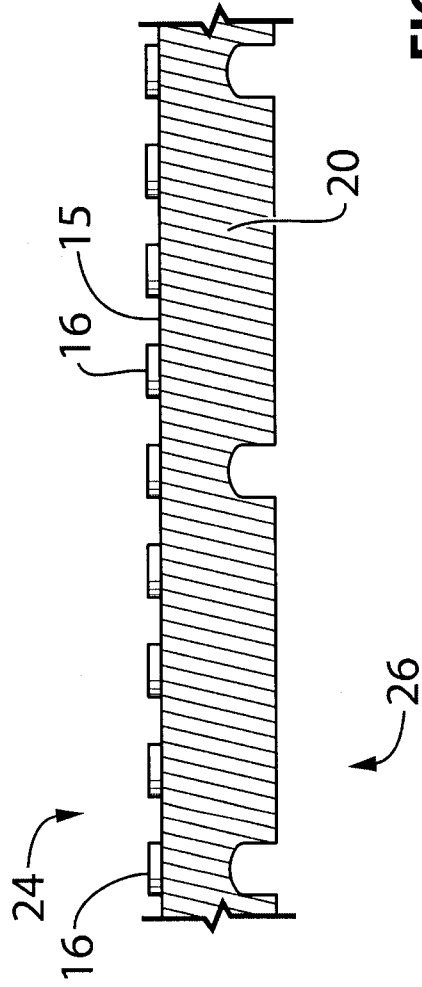

FIG. 1a

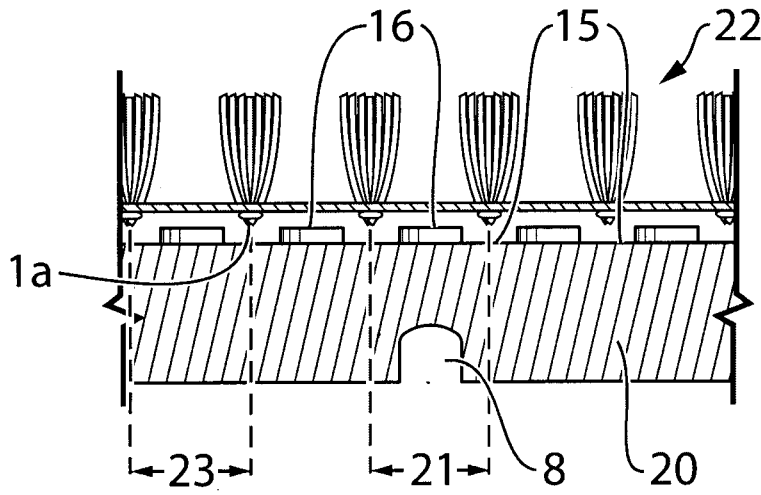

FIG. 2a

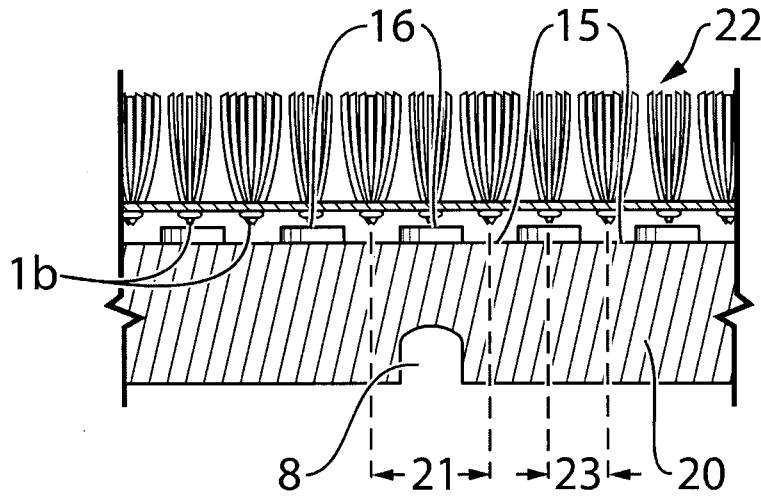

FIG. 2b

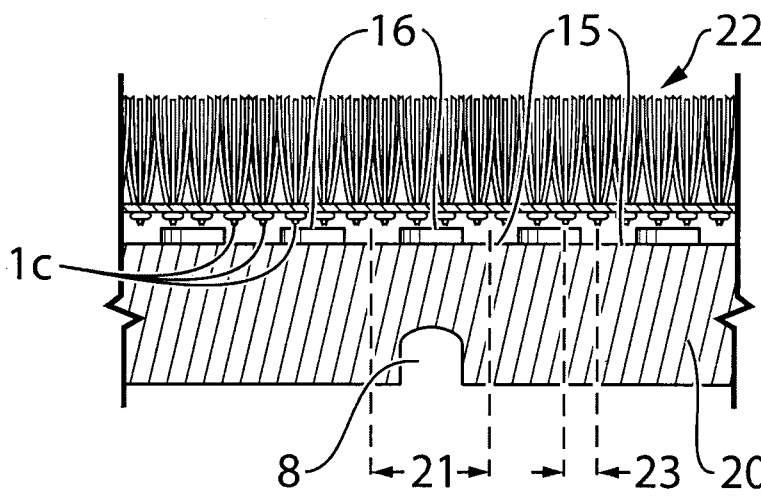

FIG. 2c

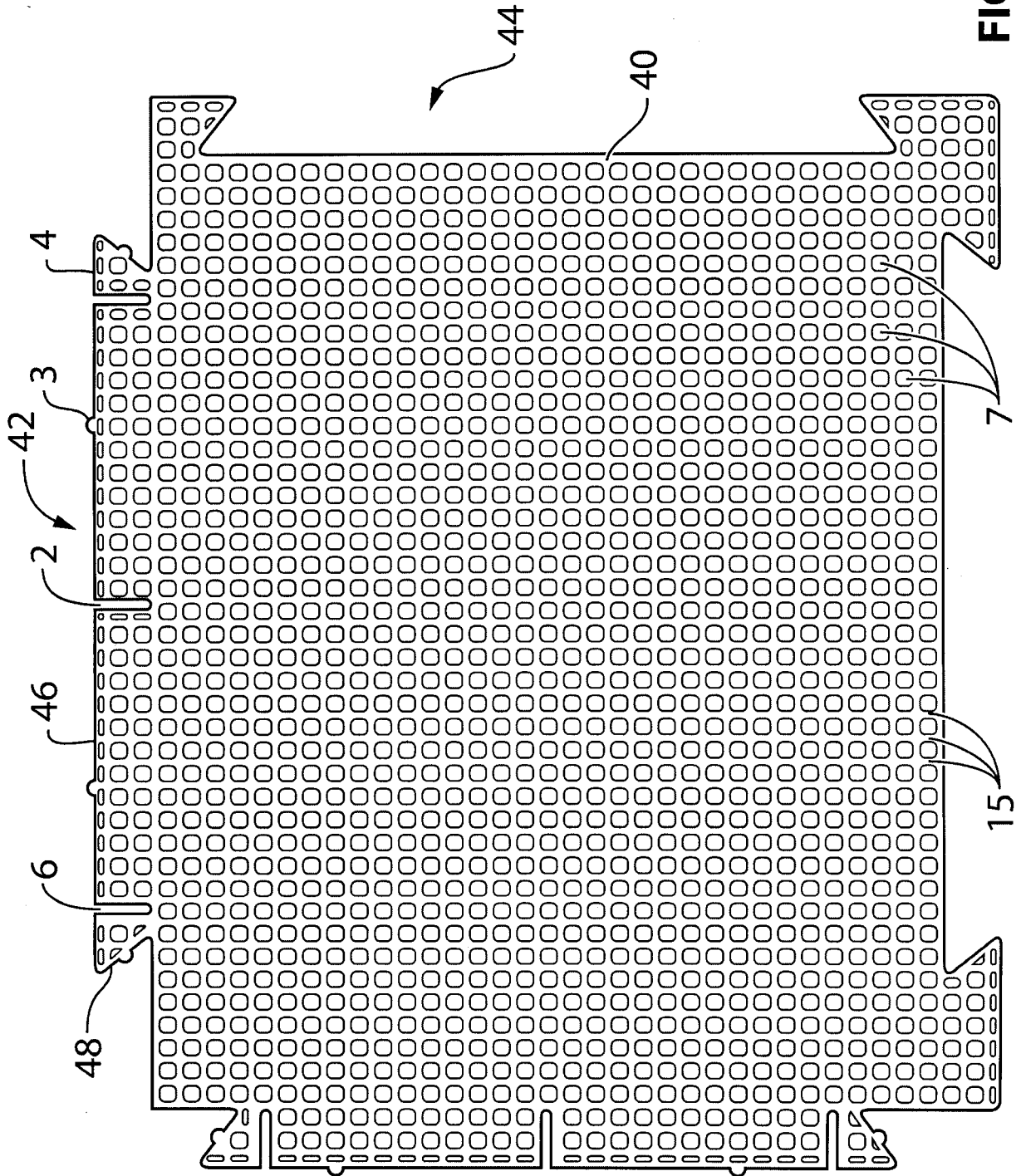

FIG. 3

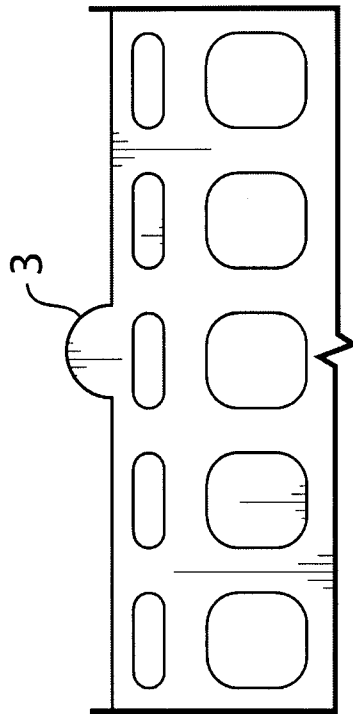

FIG. 3a

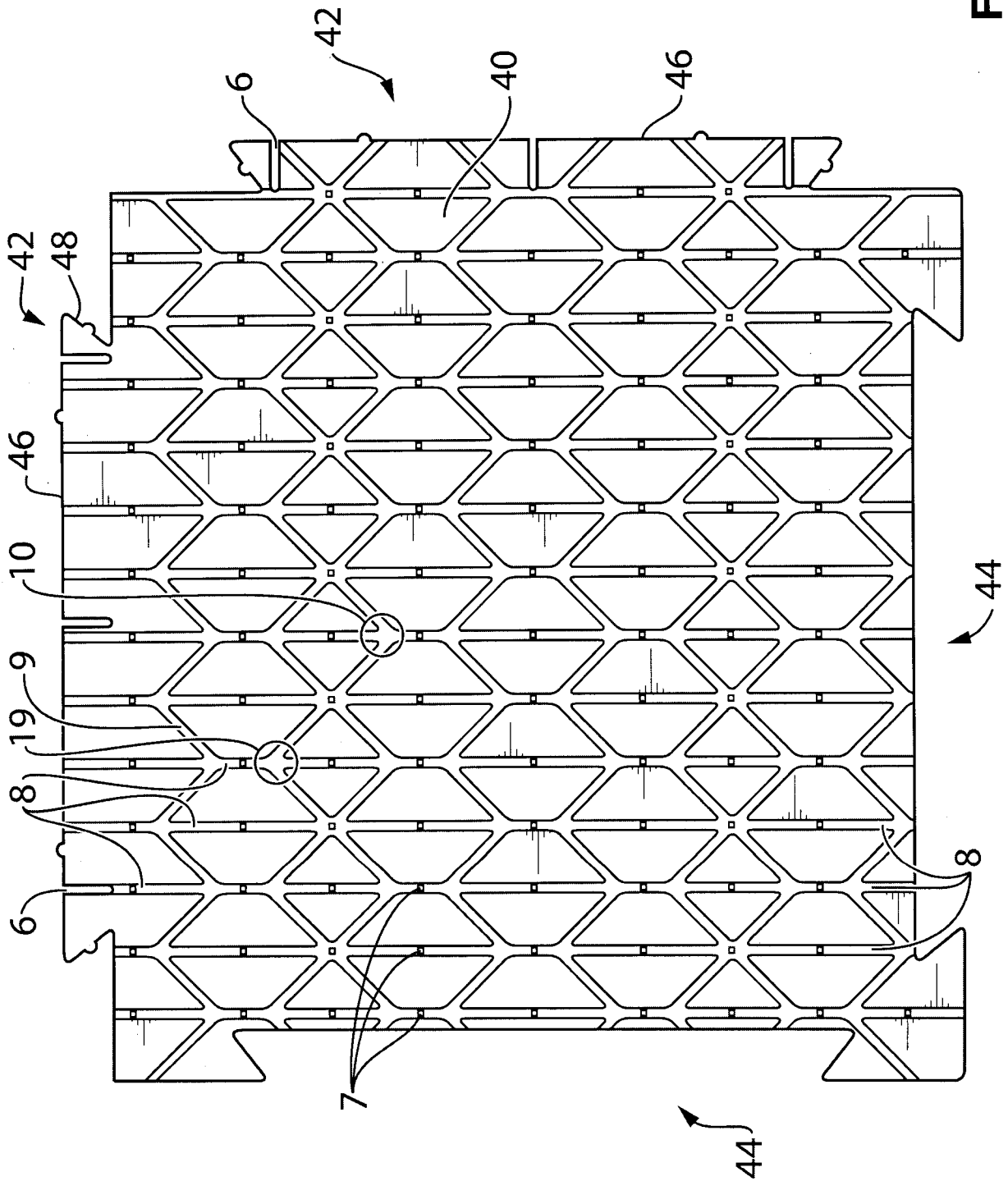

FIG. 4

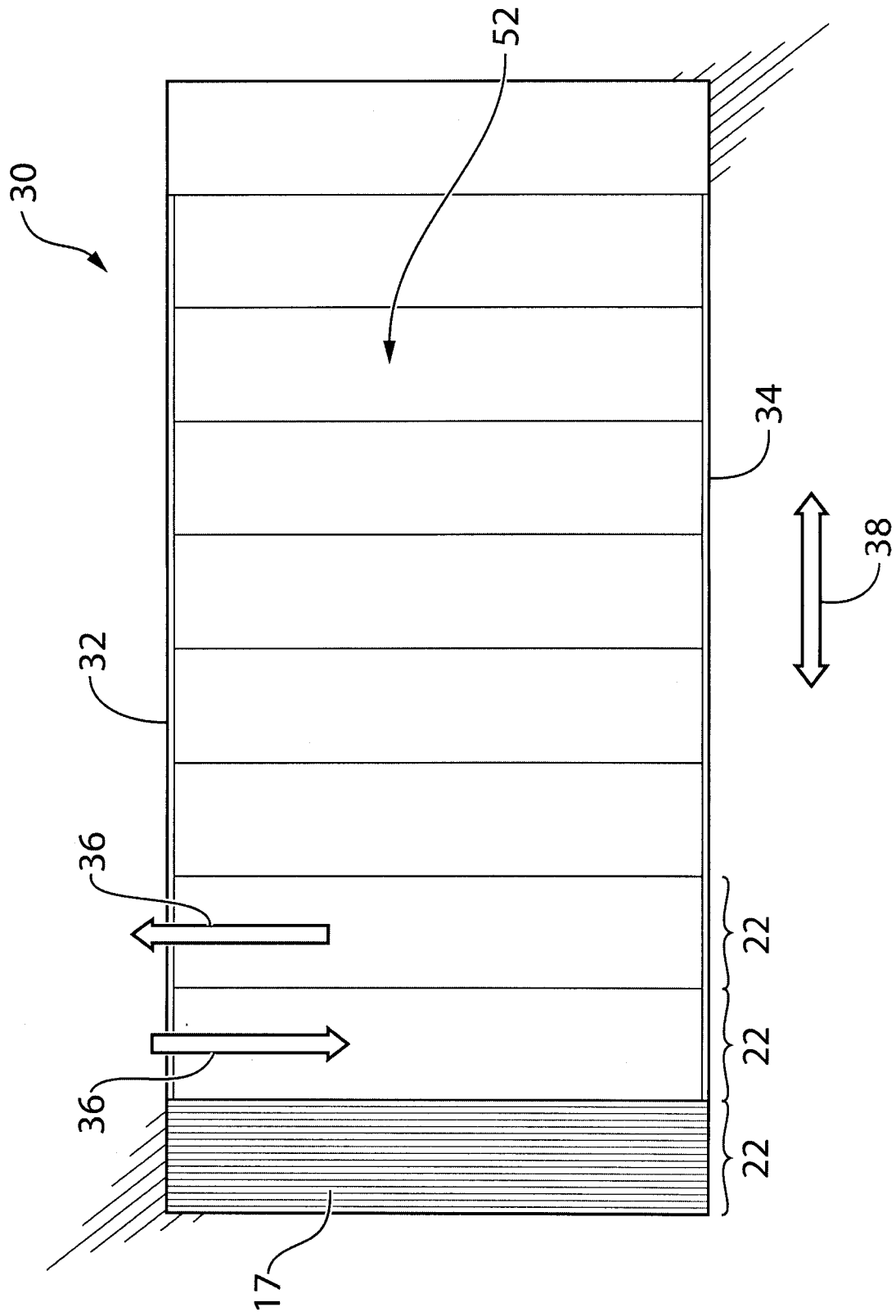

FIG. 5

INTERNATIONAL SEARCH REPORT

International application No.
PCT/CA20 11/000771

A. CLASSIFICATION OF SUBJECT MATTER
 IPC: **A63C 19/04** (2006.01) , **EOIC 13/10** (2006.01)
 According to International Patent Classification (IPC) or to both national classification and IPC

B. FIELDS SEARCHED
 Minimum documentation searched (classification system followed by classification symbols)
 IPC (2006.01): A63C 19/04. EOIC 13/10. EOIC 13/02 ECLA: EOIC 13/02. EOIC 13/08. EOIC 13/08B
 USPC: 472/92. 428/17. 428/95

Documentation searched other than minimum documentation to the extent that such documents are included in the fields searched

Electronic database(s) consulted during the international search (name of database(s) and, where practicable, search terms used)
 Epoque (Epodoc, English Full-Text Databases)
 Keywords: artificial 4w field+, drain+, channel

C. DOCUMENTS CONSIDERED TO BE RELEVANT

Category*	Citation of document, with indication, where appropriate, of the relevant passages	Relevant to claim No.
A	US2008/0176010A1 (SAWYER, S., et al.) 24 July 2008 (24-07-2008) *Figures 1 & 2; paragraphs 31-50*	1, 19, 20
A	US7357966 B2 (DIPPLE, T., et al.) 15 April 2008 (15-04-2008) *Figure 1; Column 4, lines 44-65*	1, 19, 20
A, P	WO201 1/07484 1A2 (LEE, S.) 23 June 201 1 (23-06-201 1) *Figure 1*	1, 19, 20

Further documents are listed in the continuation of Box C. See patent family annex.

* Special categories of cited documents :	"T" later document published after the international filing date or priority date and not in conflict with the application but cited to understand the principle or theory underlying the invention
"A" document defining the general state of the art which is not considered to be of particular relevance	"X" document of particular relevance; the claimed invention cannot be considered novel or cannot be considered to involve an inventive step when the document is taken alone
"E" earlier application or patent but published on or after the international filing date	"Y" document of particular relevance; the claimed invention cannot be considered to involve an inventive step when the document is combined with one or more other such documents, such combination being obvious to a person skilled in the art
"L" document which may throw doubts on priority claim(s) or which is cited to establish the publication date of another citation or other special reason (as specified)	"&" document member of the same patent family
"O" document referring to an oral disclosure, use, exhibition or other means	
"P" document published prior to the international filing date but later than the priority date claimed	

Date of the actual completion of the international search 22 September 2011 (22-09-2011)	Date of mailing of the international search report 27 September 2011 (27-09-2011)
---	--

Name and mailing address of the ISA/CA Canadian Intellectual Property Office Place du Portage I, CI 14 - 1st Floor, Box PCT 50 Victoria Street Gatineau, Quebec K1A 0C9 Facsimile No.: 001-819-953-2476	Authorized officer Kurtis Ulicny (819) 934-6356
--	--

INTERNATIONAL SEARCH REPORT
Information on patent family members

International application No.
PCT/CA20 11/000771

Patent Document Cited in Search Report	Publication Date	Patent Family Member(s)	Publication Date
US2008176010A1	24 July 2008 (24-07-2008)	EP21 11491A2 EP2298995A2 EP2298996A2 EP2348157A2 US2010284740A1 US201 1135852A1 US201 1173901A1 WO2008088919A2 WO2008088919A3 WO201 1005747A2 WO201 1100514A2	28 October 2009 (28-10-2009) 23 March 201 1 (23-03-201 1) 23 March 201 1 (23-03-201 1) 27 July 201 1 (27-07-201 1) 11 November 2010 (11-11-2010) 09 June 201 1 (09-06-201 1) 21 July 201 1 (21-07-201 1) 24 July 2008 (24-07-2008) 27 November 2008 (27-11-2008) 13 January 201 1 (13-01-201 1) 18 August 201 1 (18-08-201 1)
US7357966B2	15 April 2008 (15-04-2008)	GB0516027D0 GB2420986A US2006045994A1 US2006045995A1 US2007009680A1 WO2006025973A2 WO2006025973A3	14 September 2005 (14-09-2005) 14 June 2006 (14-06-2006) 02 March 2006 (02-03-2006) 02 March 2006 (02-03-2006) 11 January 2007 (11-01-2007) 09 March 2006 (09-03-2006) 11 May 2006 (11-05-2006)
WO20 1107484 1A2	23 June 201 1 (23-06-201 1)	KR201 10068249A	22 June 201 1 (22-06-201 1)