



- (51) International Patent Classification:
A24F 47/00 (2006.01)
- (21) International Application Number:
PCT/EP2016/057060
- (22) International Filing Date:
31 March 2016 (31.03.2016)
- (25) Filing Language: English
- (26) Publication Language: English
- (30) Priority Data:
1505595.7 31 March 2015 (31.03.2015) GB
- (71) Applicant: **BRITISH AMERICAN TOBACCO (INVESTMENTS) LIMITED** [GB/GB]; Globe House, 1 Water Street, London Greater London WC2R 3LA (GB).
- (72) Inventors: **SUTTON, Joseph**; c/o Globe House, 1 Water Street, London Greater London WC2R 3LA (GB). **WOODCOCK, Dominic**; c/o Globe House, 1 Water Street, London Greater London WC2R 3LA (GB). **SEYMOUR, Darren**; c/o PA Consulting Holdings Limited, 123 Buckingham Palace Road, London Greater London SW1W 9SR (GB). **VALLABH, Hitesh**; c/o PA Consulting Holdings Limited, 123 Buckingham Palace Road, London Greater London SW1W 9SR (GB). **LITTEN, Neil**; c/o PA Consulting Holdings Limited, 123 Buckingham Palace Road, London Greater London SW1W 9SR (GB). **SINGH, Harpal**; c/o PA Consulting Holdings Limited, 123 Buckingham Palace Road, London Greater London SW1W 9SR

(GB). **RUSSELL, David**; c/o PA Consulting Holdings Limited, 123 Buckingham Palace Road, London Greater London SW1W 9SR (GB). **BITAR, Ahmad**; c/o PA Consulting Holdings Limited, 123 Buckingham Palace Road, London Greater London SW1W 9SR (GB).

(74) Agent: **EIP**; Fairfax House, 15 Fulwood Place, London Greater London WC1V 6HU (GB).

(81) Designated States (unless otherwise indicated, for every kind of national protection available): AE, AG, AL, AM, AO, AT, AU, AZ, BA, BB, BG, BH, BN, BR, BW, BY, BZ, CA, CH, CL, CN, CO, CR, CU, CZ, DE, DK, DM, DO, DZ, EC, EE, EG, ES, FI, GB, GD, GE, GH, GM, GT, HN, HR, HU, ID, IL, IN, IR, IS, JP, KE, KG, KN, KP, KR, KZ, LA, LC, LK, LR, LS, LU, LY, MA, MD, ME, MG, MK, MN, MW, MX, MY, MZ, NA, NG, NI, NO, NZ, OM, PA, PE, PG, PH, PL, PT, QA, RO, RS, RU, RW, SA, SC, SD, SE, SG, SK, SL, SM, ST, SV, SY, TH, TJ, TM, TN, TR, TT, TZ, UA, UG, US, UZ, VC, VN, ZA, ZM, ZW.

(84) Designated States (unless otherwise indicated, for every kind of regional protection available): ARIPO (BW, GH, GM, KE, LR, LS, MW, MZ, NA, RW, SD, SL, ST, SZ, TZ, UG, ZM, ZW), Eurasian (AM, AZ, BY, KG, KZ, RU, TJ, TM), European (AL, AT, BE, BG, CH, CY, CZ, DE, DK, EE, ES, FI, FR, GB, GR, HR, HU, IE, IS, IT, LT, LU, LV, MC, MK, MT, NL, NO, PL, PT, RO, RS, SE, SI, SK, SM, TR), OAPI (BF, BJ, CF, CG, CI, CM, GA, GN, GQ, GW, KM, ML, MR, NE, SN, TD, TG).

[Continued on next page]

(54) Title: CARTRIDGE, POUCH AND METHOD OF MANUFACTURE OF POUCH FOR USE WITH APPARATUS FOR HEATING SMOKABLE MATERIAL

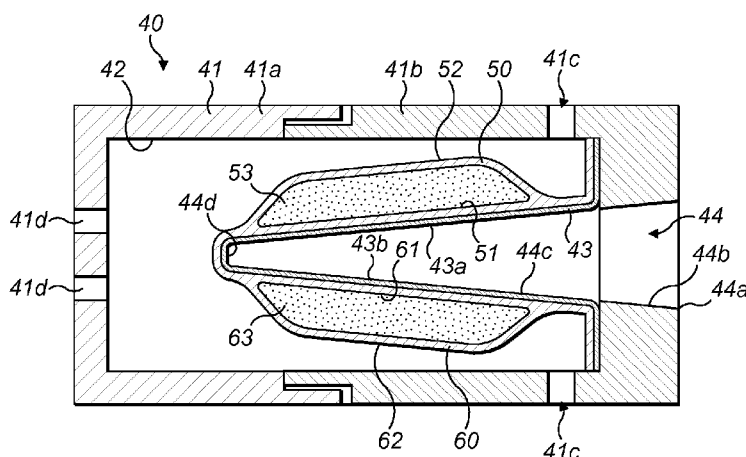

FIG. 2

(57) Abstract: A cartridge (40) is provided for use with an apparatus (1) for heating smokable material (53). The cartridge (40) has a housing (41) defining a chamber (42) and a pouch (50) containing smokable material (53). The pouch (50) is located within the chamber (42). At least part of the pouch (50) is made of porous material for permitting aerosol or volatilised material generated within the pouch (50) to pass out of the pouch (50) from within the pouch (50). There is also provided a pouch (50) having a first wall (51) and a second wall (52). The pouch (50) contains smokable material (53) between the first wall (51) and the second wall (52). A method of manufacturing a pouch (50) is also disclosed in which the first wall (51) is attached to the second wall (52) with smokable material (53) between the first wall (51) and second wall (52).



Published:

- *without international search report and to be republished upon receipt of that report (Rule 48.2(g))*

CARTRIDGE, POUCH AND METHOD OF MANUFACTURE OF POUCH FOR
USE WITH APPARATUS FOR HEATING SMOKABLE MATERIAL

Technical Field

5 The present invention relates to a cartridge for use with apparatus for heating smokable material to volatilise at least one component of the smokable material, to a pouch for use with apparatus for heating smokable material to volatilise at least one component of the smokable material, and to a method of manufacturing a pouch for use with apparatus for heating smokable material.

10

Background

Smoking articles such as cigarettes, cigars and the like burn tobacco during use to create tobacco smoke. Attempts have been made to provide alternatives to these articles by creating products that release compounds without combusting. Examples of such products are so-called "heat not burn" products or tobacco heating devices or products, which release compounds by heating, but not burning, material. The material may be, for example, tobacco or other non-tobacco products, which may or may not contain nicotine.

20 Summary

According to a first aspect of the present invention, there is provided a cartridge for use with apparatus for heating smokable material to volatilise at least one component of the smokable material, the cartridge comprising:

- a housing defining a chamber; and
- 25 a pouch containing smokable material, wherein:
 - the pouch is located within the chamber;
 - at least part of the pouch is made of porous material for permitting aerosol or volatilised material generated within the pouch to pass out of the pouch from within the pouch;
 - 30 the pouch defines part of an exterior surface of the cartridge;
 - the exterior surface of the cartridge comprises a cavity for receiving in use a heating device for heating the smokable material; and

the pouch defines at least part of the cavity.

In an exemplary embodiment, the pouch is a first pouch that defines a first part of the cavity;

5 the cartridge comprises a second pouch that contains smokable material and defines a second part of the cavity; and

at least part of the second pouch is made of porous material for permitting aerosol or volatilised material generated within the second pouch to pass out of the second pouch from within the second pouch.

10

In an exemplary embodiment, the first and second pouches define opposite sides of the cavity.

In an exemplary embodiment, the first pouch is unitary with the second pouch.

15

In an exemplary embodiment, the cavity has a mouth and a longitudinal axis, and a cross-sectional size of the cavity perpendicular to the axis decreases with distance from the mouth over at least a majority of a length of the cavity.

20 In an exemplary embodiment, the cross-sectional size of the cavity decreases with distance from the mouth over the full length of the cavity.

In an exemplary embodiment, the pouch comprises a first wall made of a first material, and a second wall made of a second material that is a different material to the first material; and

25

the smokable material is arranged between the first wall and the second wall.

In an exemplary embodiment, the second wall is porous for permitting aerosol or volatilised material generated within the pouch to pass out of the pouch from within the pouch, and the first wall is less porous to the aerosol or volatilised material than the second wall.

30

In an exemplary embodiment, the first wall comprises one or more materials selected from the group consisting of: foil, paper, a polymer, a plastics material, and a combination of foil and paper.

5 In an exemplary embodiment, the pouch is attached to the housing.

In an exemplary embodiment, the pouch is attached to the housing by an adhesive.

10 In an exemplary embodiment, the housing comprises a first housing part connected to a second housing part, and a portion of the pouch is trapped between the first housing part and the second housing part so as to attach the pouch to the housing.

15 In an exemplary embodiment, the housing has an air flow inlet extending therethrough for admitting air into the chamber from an exterior of the housing.

In an exemplary embodiment, the housing has a volatilised material outlet extending therethrough for permitting aerosol or volatilised material generated within the pouch to pass from the chamber out of the housing.

20

In an exemplary embodiment, the cartridge comprises a mass of aerosol containment material within the chamber.

25 In an exemplary embodiment, the pouch contains the mass of aerosol containment material.

In an exemplary embodiment, the aerosol containment material comprises one or more materials selected from the group consisting of: wadding, fleece, non-woven material, non-woven fleece, woven material, knitted material, nylon, foam, polystyrene, polyester, polyester filament, polypropylene, and a blend of polyester and polypropylene.

30

In an exemplary embodiment, at least part of the pouch comprises one or more materials selected from the group consisting of: fleece, viscose, non-woven material, non-woven fleece, woven material, knitted material, nylon, and polyester.

5 In an exemplary embodiment, the smokable material comprises tobacco.

In an exemplary embodiment, the smokable material comprises an aerosol forming agent.

10 In an exemplary embodiment, the aerosol forming agent comprises glycerol.

According to a second aspect of the present invention, there is provided a pouch for use with apparatus for heating smokable material to volatilise at least one component of the smokable material, the pouch comprising:

15 a first wall made of a first material; and

a second wall made of a second material that is a different material to the first material;

wherein the pouch contains smokable material between the first wall and the second wall.

20

In an exemplary embodiment, the second wall is porous for permitting aerosol or volatilised material generated within the pouch to pass out of the pouch from within the pouch, and the first wall is less porous to the aerosol or volatilised material than the second wall.

25

In an exemplary embodiment, the second material comprises one or more materials selected from the group consisting of: fleece, viscose, non-woven material, non-woven fleece, woven material, knitted material, nylon, and polyester.

30 In an exemplary embodiment, the first wall comprises one or more materials selected from the group consisting of: foil, paper, a polymer, a plastics material, and a combination of foil and paper.

In an exemplary embodiment, the smokable material comprises tobacco.

In an exemplary embodiment, the smokable material comprises an aerosol
5 forming agent.

In an exemplary embodiment, the aerosol forming agent comprises glycerol.

According to a third aspect of the present invention, there is provided a method
10 of manufacturing a pouch for use with apparatus for heating smokable material to
volatilise at least one component of the smokable material, the method comprising:

providing a first wall made of a first material, and a second wall made of a
second material that is a different material to the first material; and

attaching the first wall to the second wall with the smokable material between
15 the first wall and the second wall.

In an exemplary embodiment, the method comprises depositing the smokable
material onto the second wall, and then attaching the first wall to the second wall with
the smokable material between the first wall and the second wall.

20

In an exemplary embodiment, the second wall defines a pocket, and the
depositing comprises depositing the smokable material into the pocket.

In an exemplary embodiment, the depositing comprises depositing the smokable
25 material and aerosol containment material into the pocket.

In an exemplary embodiment, the second wall is porous for permitting aerosol
or volatilised material generated within the pouch to pass out of the pouch from within
the pouch, and the first wall is less porous to the aerosol or volatilised material than the
30 second wall.

In an exemplary embodiment, the second material comprises one or more materials selected from the group consisting of: fleece, viscose, non-woven material, non-woven fleece, woven material, knitted material, nylon, and polyester.

5 In an exemplary embodiment, the first wall comprises one or more materials selected from the group consisting of: foil, paper, a polymer, a plastics material, and a combination of foil and paper.

In an exemplary embodiment, the smokable material comprises tobacco.

10

Brief Description of the Drawings

Embodiments of the invention will now be described, by way of example only, with reference to the accompanying drawings, in which:

15 Figure 1 shows a schematic top view of an example of a cartridge for use with apparatus for heating smokable material to volatilise at least one component of the smokable material;

Figure 2 shows a schematic cross-sectional view of the cartridge of Figure 1;

20

Figure 3 shows a schematic perspective view of a second body of a second material used in a method of manufacturing an assembly of pouches;

25 Figure 4 shows a schematic perspective view of the second body of Figure 3 and smokable material deposited in pockets defined by the second body;

Figure 5 shows a schematic perspective view of a first body of a first material being attached to the second body of Figure 4 with the smokable material between the first body and the second body;

30

Figure 6 shows a schematic perspective view of the manufactured assembly of pouches; and

Figure 7 shows a partially cut-away perspective view of an example of an apparatus for heating smokable material to volatilise at least one component of the smokable material.

5

Detailed Description

As used herein, the term “smokable material” includes materials that provide volatilised components upon heating, typically in the form of an aerosol. “Smokable material” may be a non-tobacco-containing material or a tobacco-containing material. “Smokable material” may, for example, include one or more of tobacco per se, tobacco derivatives, expanded tobacco, reconstituted tobacco, tobacco extract, homogenised tobacco or tobacco substitutes. The smokable material can be in the form of ground tobacco, cut rag tobacco, extruded tobacco, gel or agglomerates. “Smokable material” also may include other, non-tobacco, products, which, depending on the product, may or may not contain nicotine.

Referring to Figures 1 and 2, there are shown a schematic top view and a schematic cross-sectional view of an example of a cartridge 40 according to an embodiment of the invention.

The cartridge 40 of this embodiment comprises a housing 41 defining a chamber 42. In this embodiment, the housing 41 comprises a first housing part 41a and a second housing part 41b that is non-unitary with the first housing part 41a. The first housing part 41a is attached to the second housing part 41b, such as by a snap-fit connection, adhesive, or the like. In other embodiments, the housing 41 may take a different form. For example, in some embodiments the first and second housing parts 41a, 41b may be unitary, such as following welding, e.g. sonic welding. In some embodiments, the first and second housing parts 41a, 41b may be unitary and connected by a living hinge. The first and second housing parts 41a, 41b may be made of any suitable material, such as a plastics material.

The cartridge 40 further comprises a first pouch 50 and a second pouch 60. In this embodiment, the first pouch 50 is unitary with the second pouch 60, and together the first and second pouches are referred to herein as an assembly of the pouches 50, 60. However, in other embodiments, the first pouch 50 may be non-unitary with the second pouch 60. Each of the pouches 50, 60 contains smokable material 53, 63. Each of the pouches 50, 60 comprises a first wall 51, 61 and a second wall 52, 62, and in each pouch 50, 60 the smokable material 53, 63 is arranged between the first wall 51, 61 and the second wall 52, 62. In this embodiment, the first wall 51, 61 of each of the pouches 50, 60 is made of a first material, and the second wall 52, 62 of each of the pouches 50, 60 is made of a second material that is a different material to the first material. However, in other embodiments, the first and second walls 51, 52, 61, 62 may be made of the same material, such as the second material.

In this embodiment, part of each of the pouches 50, 60 is made of porous material for permitting aerosol or volatilised material generated within the pouch 50, 60 on heating the smokable material 53, 63 to pass out of the pouch 50, 60 from within the pouch 50, 60. In this embodiment, in each pouch 50, 60, the second wall 52, 62 is made of such a porous material, and the first wall 51, 61 is made of a material that is less porous to the aerosol or volatilised material than the porous material. Therefore, in this embodiment, in each pouch 50, 60, the second wall 52, 62 is porous for permitting aerosol or volatilised material generated within the pouch 50, 60 to pass out of the pouch 50, 60, and the first wall 51, 61 is less porous to the aerosol or volatilised material than the second wall 52, 62. However, in other embodiments, each of the first and second walls 51, 52, 61, 62 of the pouches 50, 60 may be made of porous material for permitting the aerosol or volatilised material to pass out of the pouch 50, 60. The porous material may, for example, comprise one or more materials selected from the group consisting of: fleecy, viscose, non-woven material, non-woven fleecy, woven material, knitted material, nylon, and polyester. The first material may comprise one or more of a foil, a metal foil, a non-metal foil, paper, a polymer, a plastics material, or a combination of foil and paper, such as paper overlaid with foil, or the like.

Each of the pouches 50, 60 is located within the chamber 42. In this embodiment, each of the pouches 50, 60 is attached to the housing 41. More specifically, in this embodiment, each of the pouches 50, 60 is attached to an inner surface of the second housing part 41b, such as by an adhesive or by pinning. In one embodiment, the method of manufacturing the cartridge 40 comprises attaching the pouches 50, 60 to the inner surface of the second housing part 41b, and then attaching the first housing part 41a to the second housing part 41b to surround the pouches 50, 60 within the housing 41. However, in other embodiments, one or each of the pouches 50, 60 may be attached to the housing 41 in a different manner. For example, in some embodiments, one or each of the pouches 50, 60 may have a portion that is trapped between the first housing part 41a and the second housing part 41b so as to attach the or each pouch 50, 60 to the housing 41. In some embodiments, one or both of the pouches 50, 60 may not be attached to the housing 41.

In this embodiment, the assembly of the pouches 50, 60 comprises a carrier 43. The first walls 51, 61 of the first and second pouches 50, 60 comprise respective first and second portions 43a, 43b of the carrier 43. The carrier 43 may act to support the rest of the first and second pouches 50, 60. In some embodiments, the carrier 43 is more rigid or robust than each of the second walls 52, 62 of the first and second pouches 50, 60. The carrier 43 is thermally-conductive and is for conducting heat from the cavity 44 to the smokable material 53, 63 in the pouches 50, 60. In this embodiment, the carrier 43 comprises a metal foil, such as aluminium foil, but in other embodiments the carrier 43 may comprise one or more materials selected from the group consisting of: foil, paper, a polymer, a plastics material, and a combination of foil and paper. In some embodiments, the carrier 43 may be omitted, or may not be part of the assembly of the pouches 50, 60 as such.

An exterior surface of the cartridge 40 comprises a cavity 44 for receiving a heating device for heating the smokable material 53, 63. In an embodiment, the cavity 44 in use receives a heater of an apparatus that has a heater which is engaged in use by the cartridge. The "exterior surface" may be a surface that envelops the rest of the cartridge 40, or that delineates the cartridge 40. The exterior surface of the cartridge 40

comprises a portion that is recessed to provide the cavity 44. In this embodiment, each of the pouches 50, 60 defines part of the cavity 44. That is, the first pouch 50 defines a first part of the cavity 44, and the second pouch 60 defines a second part of the cavity 44. Accordingly, in this embodiment, each of the pouches 50, 60 defines part of the exterior surface of the cartridge 40. In this embodiment, the first walls 51, 61 of the pouches 50, 60 define the first and second parts, respectively, of the cavity 44. More specifically, the first and second portions 43a, 43b of the carrier 43 define the first and second parts, respectively, of the cavity 44. In this embodiment, the first and second parts of the cavity 44 are opposite sides of the cavity 44, so that the cavity 44 is located between the first and second pouches 50, 60. In another embodiment that is a variant of this embodiment, the second pouch 60 may be omitted. In such a variant, the first wall 51 of the pouch may define part of the cavity 44, and the rest of the cavity 44 may be defined by one or more further elements.

In this embodiment, the cavity 44 has a mouth 44a, first and second trunk sections 44b, 44c, and a closed end 44d. The first trunk section 44b connects the mouth 44a to the second trunk section 44c, and the second trunk section 44c connects the first trunk section 44b to the closed end 44d. The cavity 44 has a length that is measured from the mouth 44a to the closed end 44d, and that extends along an axis of the cavity 44. In this embodiment, the second housing part 41b defines the mouth 44a and a first trunk section 44b, whereas the pouches 50, 60 define the second trunk section 44c and the closed end 44d.

In this embodiment, the pouches 50, 60 and the second housing part 41b are shaped and relatively positioned so that the cavity 44 is a wedge-shaped cavity 44. In this embodiment, the wedge-shaped cavity 44 is symmetrical or rotationally-symmetrical. In other embodiments, it may instead be asymmetrical. A cross-sectional size (for example, a width, a height, a diameter, a dimension, or an area) of the cavity 44 decreases with distance from the mouth 44a over the full length of the cavity 44 from the mouth 44a to the closed end 44d. In this embodiment, the cross-sectional size of the cavity 44 decreases at a linear rate with distance from the mouth 44a. In other embodiments, the rate may be non-linear. For example, in some embodiments, the

cross-sectional size (for example, a width, a height, a diameter, a dimension, or an area) of the first trunk section 44b may decrease at a first rate with distance from the mouth 44a, whereas the cross-sectional size (for example, a width, a height, a diameter, a dimension, or an area) of the second trunk section 44c may decrease at a second, 5 different rate with distance from the first trunk section 44b. The second rate may be more than the first rate.

The tapered profile may help a user to guide the heating device into the cavity 44. By providing that the cross-sectional size of the cavity 44 decreases with distance 10 from the mouth 44a over the full length of the cavity 44, the heating device may be introducible into the cavity 44 in a direction non-parallel to the first walls 51, 61 of the pouches 50, 60. Therefore, the heating device may be a close fit with the first walls 51, 61 of the pouches 50, 60 in use. This provides good conduction of heat from the heating device to the pouches 50, 60 and the smokable material 53, 63, yet rubbing of the 15 heating device against the pouches 50, 60 during such insertion of the heating device may be minimised or avoided. This can help reduce or avoid the pouches 50, 60 being torn or otherwise damaged by insertion of the heating device, and reduces wear of the heating device.

20 In some other embodiments, the pouches 50, 60 and the second housing part 41b may be shaped and relatively positioned so that the cavity 44 is other than wedge-shaped, such as dome-shaped. Such a dome-shaped cavity may be symmetrical or rotationally-symmetrical, or asymmetrical. In some embodiments, the cavity 44 may be of constant, or substantially constant, cross-sectional shape and size (for example, a 25 width, a height, a diameter, a dimension, or an area) over a majority, or only a majority, of the length of the cavity 44.

In this embodiment, air flow inlets 41c extend through the second housing part 41b for admitting air into the chamber 42 from an exterior of the housing 41. In other 30 embodiments, there may be only one air flow inlet 41c in place of the plurality of air flow inlets 41c, or the air flow inlet(s) 41c may take some other form and/or may extend through a different part of the housing 41.

In this embodiment, apertures 41d extend through the first housing part 41a. Each of the apertures 41d is a volatilised material outlet 41d for permitting volatilised material generated within the pouches 50, 60 by heating of the smokable material 53, 63 to pass from the chamber 42 out of the housing 41. In other embodiments, there may be only one aperture 41d in place of the plurality of apertures 41d, or the volatilised material outlet(s) 41d may take some other form and/or may extend through a different part of the housing 41.

In some embodiments, one or each of the pouches 50, 60 contains a mass of aerosol containment material. The mass of aerosol containment material is a porous material for the containment of aerosol generated in the pouches 50, 60 in use by heating the smokable material 53, 63. In some embodiments, in each of the pouches 50, 60 the mass of aerosol containment material may be located between the smokable material 53, 63 and the second wall 52, 62 of the pouch 50, 60. In some embodiments, the smokable material 53, 63 is in contact with the mass of aerosol containment material. In other embodiments, one or each of the pouches 50, 60 may itself comprise a mass of aerosol containment material. For example, in some embodiments, the second wall 52, 62 of one or each of the pouches 50, 60 may comprise a mass of aerosol containment material. The aerosol containment material may comprise wadding or fleece, such as with a density of about 100 gsm or about 120 gsm. Other aerosol containment materials that may be used in other embodiments are discussed below. In some embodiments, the mass of aerosol containment material may be omitted from the cartridge 40.

The cartridge 40 shown in Figures 1 and 2 is usable with an apparatus (not shown) for heating the smokable material 53, 63 to volatilise at least one component of the smokable material. In some embodiments, the apparatus is for heating the smokable material 53, 63 of the cartridge 40 to volatilise at least one component of the smokable material 53, 63 without combusting, or burning, the smokable material.

30

In some respective embodiments, the apparatus comprises a heating device for contacting, or for coming into close proximity to, the pouches 50, 60 of the cartridge

40. In some embodiments, the heating device has a surface profile that matches, or closely matches, a surface profile of the first walls 51, 61 of the pouches 50, 60, or matches, or closely matches, a surface profile of the cavity 44. This helps provide good conduction of heat from the heating device to the carrier 43, and the smokable material
5 53, 63 contained in the pouches 50, 60.

In some embodiments, the apparatus comprises a controller for controlling heating of the heating device so as to cause heating of the smokable material 53, 63 to volatilise the at least one component of the smokable material 53, 63 without
10 combusting the smokable material 53, 63. In some embodiments, the controller is for controlling the supply of power from a power source to the heating device. In some embodiments, the controller is configured to ensure that the temperature of the heating device remains within a temperature range of about 150 degrees Celsius to about 300 degrees Celsius, or about 170 degrees Celsius to about 220 degrees Celsius. In some
15 embodiments, within this temperature range, the smokable material 53, 63 of the cartridge 40 is heated sufficiently to volatilise at least one component of the smokable material 53, 63 without combusting the smokable material 53, 63. In other embodiments, the temperature range of heating may be other than this range. In some embodiments, following the volatilisation of the at least one component of the smokable
20 material 53, 63, an aerosol for inhalation by a user is formed. For example, a user drawing on an outlet of the apparatus may draw air through the apparatus, which cools the volatilised component(s) of the smokable material 53, 63 so that they condense to form the aerosol.

25 In some embodiments, the heating device of the apparatus may comprise a first heater and a second heater. When the heating device is in the cavity 44 of the cartridge 40, the first heater may be closer to the smokable material 53 contained in the first pouch 50 than to the smokable material 63 contained in the second pouch 60, and the second heater may be closer to the smokable material contained in the second pouch 60
30 than to the smokable material 53 contained in the first pouch 50. Therefore, in use, the first heater may be predominantly for heating the smokable material 53 contained in the first pouch 50, and the second heater may be predominantly for heating the smokable

material contained in the second pouch 60. The controller of the apparatus may be for controlling the supply of power from the power source to the first heater independently of the supply of power from the power source to the second heater. The manner in which the controller causes the first and second heaters to be heated may be selectable
5 by a user. Thus, in some embodiments, a user may be able to select which of the first and second heaters is to be heated, and thus which of pouches is predominantly to be heated. In embodiments in which the first and second pouches 50, 60 contain different forms or compositions of smokable material 53, 63, a user may thus be able to select or configure the type of aerosol they wish to generate, and thus the experience they wish
10 to have on inhaling the aerosol.

Referring to Figures 3 to 6, a method for manufacturing the assembly of the first and second pouches 50, 60 of the cartridge 40 shown in Figures 1 and 2 will be described. In summary, the method comprises the step of providing a first body 151
15 made of a first material and a second body 152 made of a second material that is a different material to the first material; depositing the smokable material 53, 63 onto the second body 152 in discrete quantities; and then attaching the first body 151 to the second body 152 with the discrete quantities of smokable material 53, 63 between the first body 151 and the second body 152, so as to form pouches 50, 60 containing the
20 respective discrete quantities of smokable material 53, 63 between the first and second bodies 151, 152. In the manufactured assembly, the first wall 51, 61 of each of the pouches 50, 60 is provided by part of the first body 151, and the second wall 52, 62 of each of the pouches 50, 60 is provided by part of the second body 152.

As shown in Figure 3, in this embodiment the second body 152 defines a plurality of pockets 152a, 152b for receiving the discrete quantities of smokable material 53, 63. In this embodiment, the smokable material 53, 63 is deposited in the pockets 152a, 152b, as shown in Figure 4. Then, the first body 151 is attached to the second body 152 with the smokable material 53, 63 in the pockets 152a, 152b, as shown
25 in Figure 5. After the first body 151 has been so attached to the second body 152, the smokable material 53, 63 is contained between the first and second bodies 151, 152 and in the pouches 50, 60 of the assembly so formed, as shown in Figure 6. In some
30

embodiments, the smokable material 53, 63 and aerosol containment material, such as any of the aerosol containment materials discussed herein, may be deposited in the pockets 152a, 152b. In some embodiments, the second body 152 may not define such pockets 152a, 152b, and the smokable material 53, 63 may be deposited on the second
5 body 152 in discrete quantities. In some embodiments, the smokable material 53, 63 may be provided between the first and second bodies 151, 152 in some other manner, such as by being deposited on the first body 151 before the second body 152 is attached to the first body 151.

10 In some embodiments of the method, after the first body 151 has been attached to the second body 152 to contain the smokable material 53, 63 between the first and second bodies 151, 152, the method may comprise the step of cutting through the first and second bodies 151, 152 between adjacent pouches 50, 60. The spacing of the cuts may, for example, be to define both the first and second pouches 50, 60 between
15 successive cuts, or to define only one pouch 50, 60 between successive cuts. In another embodiment of the method, one of the pouches 50, 60 may be manufactured in isolation. That is, the pouch 50, 60 may never be unitary with another pouch 50, 60.

According to the embodiment of the method described above with reference to
20 Figures 3 to 6, a pouch 50, 60 is manufactured by providing a first wall 51, 61 made of a first material and a second wall 52, 62 made of a second material that is a different material to the first material; and attaching the first wall 51, 61 to the second wall 52, 62 with the smokable material 53, 63 between the first wall 51, 61 and the second wall 52, 62. In this embodiment, the smokable material 53, 63 is deposited into a pocket
25 152a, 152b defined by the second wall 52, 62, and then the first wall 51, 61 is attached to the second wall 52, 62 with the smokable material between the first wall 51, 61 and the second wall 52, 62. The other embodiments of the method described above also result in the manufacture of a pouch 50, 60.

30 In each of the above-described methods, the second material is a porous material for permitting aerosol or volatilised material generated within the manufactured pouch 50, 60 to pass out of the pouch 50, 60 from within the pouch 50, 60, and the first material

is a material that is less porous to the aerosol or volatilised material than the porous material. The second material may comprise one or more materials selected from the group consisting of: fleece, viscose, non-woven material, non-woven fleece, woven material, knitted material, nylon, and polyester. The first material may comprise one
5 or more materials selected from the group consisting of: foil, paper, a polymer, a plastics material, and a combination of foil and paper. In other embodiments, the first body 151 or first wall 51, 61 may be made of the second material.

In each of the above described embodiments, the smokable material 53, 63
10 comprises tobacco. However, in respective variations to each of these embodiments, the smokable material 53, 63 may consist of tobacco, may consist substantially entirely of tobacco, may comprise tobacco and smokable material other than tobacco, may comprise smokable material other than tobacco, or may be free of tobacco. In some
15 embodiments, the smokable material 53, 63 may include an aerosol forming agent, such as glycerol.

In the above-described embodiments in which aerosol containment material is present in the cartridge 40, the aerosol containment material comprises wadding or fleece with a density of about 100 gsm or about 120 gsm. In other embodiments, the
20 density of the aerosol containment material may be different. However, if the density is too high, the aerosol containment material may act as a filter and attenuate generated aerosol. Alternatively, if the density is too low, the aerosol containment material may not provide effective aerosol containment. An appropriate density, particularly when the aerosol containment material comprises wadding or fleece, may be between about
25 60 and about 140 gsm, or between about 80 and about 120 gsm. In some embodiments, the aerosol containment material may have a thickness within a range of 1 mm to 2 mm.

In still further embodiments, the aerosol containment material may comprise one or more materials selected from the group consisting of: wadding, fleece, non-
30 woven material, non-woven fleece, woven material, knitted material, nylon, foam, polystyrene, polyester, polyester filament, polypropylene, and a blend of polyester and polypropylene. When a material other than wadding or fleece is used, the material

would have a density chosen to have similar thermal properties to wadding or fleece having a density of from about 80 to about 120 gsm. In each of the above-described embodiments of the cartridge or pouch, the aerosol containment material is free of smokable material. However, this need not always be the case.

5

In some embodiments, the mass of aerosol containment material is heat resistant at least over the expected range of temperatures of the heating device 20 of the apparatus that will arise in operation, such as for example 150 to 300 degrees Celsius or 170 to 220 degrees Celsius as discussed above, and will not degrade when subjected to such operation temperatures.

10

In some embodiments, the aerosol containment material helps to ensure that volatilised material generated in the pouch in use does not condense on an inner surface of the housing 41 of the cartridge 40. In some embodiments, the provision of the mass of aerosol containment material helps to increase the surface area on which aerosol generated in the pouch in use may form. In some embodiments, such a mass of aerosol containment material helps to increase the amount of visible aerosol generated in, or emitted from, the pouch in use, and thus may enhance the consumer experience.

15

20

As discussed above, in some embodiments the aerosol containment material may be omitted.

In each of the above embodiments, the cartridge 40 is a consumable cartridge. Once all, or substantially all, of the volatile component(s) of the smokable material in the cartridge 40 has/have been spent, the user may remove the cartridge from the apparatus and dispose of the cartridge. The user may subsequently re-use the apparatus with another of the cartridges 40. However, in other respective embodiments, the cartridge 40 may be non-consumable, and the combination of the apparatus and the cartridge 40 may be disposed of together once the volatile component(s) of the smokable material has/have been spent.

25

30

In some embodiments, the apparatus discussed above may be sold, supplied or otherwise provided separately from the cartridge 40 with which the apparatus is usable. However, in other embodiments, the apparatus and one or more of the cartridges 40 may be provided together as a kit.

5

Referring to Figure 7, there is shown a partially cut-away perspective view of an example of an apparatus 2 for heating smokable material to volatilise at least one component of the smokable material. The apparatus 2 is particularly suitable for use with a cartridge 40 as described above. The apparatus 2 has a body 10 which is generally tubular and elongate, has first and second opposite longitudinal ends 11, 12, and defines an interface for co-operating with the cartridge 40. In this embodiment, the interface comprises a recess 13 for receiving the cartridge 40. In other embodiments, the interface can take a different form, such as a shelf, a surface, or a projection, and optionally requires mechanical mating with the cartridge 40 in order to cooperate with the cartridge 40. The first longitudinal end 11 of the body 10 defines an opening 14 into the recess 13 at a first end of the recess 13. The opening 14 is shaped and sized so that the cartridge 40 is movable through the opening 14 to allow a user to insert the cartridge 40 into the recess 13 and/or to remove the cartridge 40 from the recess 13.

The apparatus 2 has a heating device 20. In the example shown the heating device 20 has a wedge-shape heater 21 which projects into the recess 13. The apparatus 2 shown also has electrical components such as an electrical power source 15 (such as a rechargeable or non-rechargeable battery), a controller 16 and an actuator 17 for enabling user activation of the heater 21. The wedge-shape heater 21 can be inserted into the cavity 44 of the cartridge 40 to heat the carrier 43. In an embodiment, the wedge-shape heater 21 fits snugly in the cavity 44 for efficient heat transfer to the carrier 43 and the smokable material 53, 63.

In this embodiment, the heater 21 is a folded heater 21 comprising a first heater portion 21a and a second heater portion 21b. The heater 21 has a fold 21c therein, and the first heater portion 21a is connected to the second heater portion 21b at the fold 21c. The fold 21c forms a distal end of the heater 21, which distal end is distal from the

30

retainer 18. The first heater portion 21a defines an upper surface of the heater 21, and the second heater portion 21b defines a lower surface of the heater 21. In this embodiment, the first and second heater portions 21a, 21b lie substantially in respective first and second planes, and the first and second planes meet at an acute angle.

5

In this embodiment, the apparatus 2 has a mouthpiece 30 which is generally tubular and elongate and has first and second opposite longitudinal ends 31, 32. The mouthpiece 30 comprises an inlet 34 at the second longitudinal end 32 of the mouthpiece 30, an outlet 35 at the first longitudinal end 31 of the mouthpiece 30, and a
10 channel 36 fluidly connecting the inlet 34 with the outlet 35. The second longitudinal end 32 of the mouthpiece 30 comprises a connector (not shown) that is releasably engageable with a connector (not shown) of the first longitudinal end 11 of the body 10, so as to connect the mouthpiece 30 to the body 10. In other embodiments, the mouthpiece 30 and the body 10 may be permanently connected, such as through a hinge
15 or flexible member. When the apparatus 2 is in use, the first longitudinal end 31 of the mouthpiece 30 forms a first longitudinal end of the apparatus 2, and the second longitudinal end 12 of the body 10 forms a second longitudinal end of the apparatus 2.

In order to address various issues and advance the art, the entirety of this
20 disclosure shows by way of illustration and example various embodiments in which the claimed invention may be practised and which provide for a superior cartridge and/or pouch for use with apparatus for heating smokable material to volatilise at least one component of the smokable material. The advantages and features of the disclosure are of a representative sample of embodiments only, and are not exhaustive and/or
25 exclusive. They are presented only to assist in understanding and teach the claimed and otherwise disclosed features. It is to be understood that advantages, embodiments, examples, functions, features, structures and/or other aspects of the disclosure are not to be considered limitations on the disclosure as defined by the claims or limitations on equivalents to the claims, and that other embodiments may be utilised and modifications
30 may be made without departing from the scope and/or spirit of the disclosure. Various embodiments may suitably comprise, consist of, or consist in essence of, various combinations of the disclosed elements, components, features, parts, steps, means, etc.

The disclosure may include other inventions not presently claimed, but which may be claimed in future.

CLAIMS

1. A cartridge for use with apparatus for heating smokable material to volatilise at least one component of the smokable material, the cartridge comprising:
- 5 a housing defining a chamber; and
a pouch containing smokable material, wherein:
the pouch is located within the chamber;
at least part of the pouch is made of porous material for permitting aerosol or volatilised material generated within the pouch to pass out of the pouch from within the
- 10 pouch;
the pouch defines part of an exterior surface of the cartridge;
the exterior surface of the cartridge comprises a cavity for receiving in use a heating device for heating the smokable material; and
the pouch defines at least part of the cavity.
- 15
2. A cartridge according to claim 1, wherein the pouch is a first pouch that defines a first part of the cavity;
- wherein the cartridge comprises a second pouch that contains smokable material and defines a second part of the cavity; and
- 20 wherein at least part of the second pouch is made of porous material for permitting aerosol or volatilised material generated within the second pouch to pass out of the second pouch from within the second pouch.
3. A cartridge according to claim 2, wherein the first and second pouches define
- 25 opposite sides of the cavity.
4. A cartridge according to any of claims 1 to 3, wherein the pouch comprises a first wall made of a first material, and a second wall made of a second material that is a different material to the first material; and
- 30 wherein the smokable material is arranged between the first wall and the second wall.

5. A cartridge according to claim 4, wherein the second wall is porous for permitting aerosol or volatilised material generated within the pouch to pass out of the pouch from within the pouch, and the first wall is less porous to the aerosol or volatilised material than the second wall.

5

6. A cartridge according to any of claims 1 to 5, wherein the pouch is attached to the housing.

10

7. A cartridge according to any of claims 1 to 6, comprising a mass of aerosol containment material within the chamber.

15

8. A cartridge according to claim 7, wherein the aerosol containment material comprises one or more materials selected from the group consisting of: wadding, fleece, non-woven material, non-woven fleece, woven material, knitted material, nylon, foam, polystyrene, polyester, polyester filament, polypropylene, and a blend of polyester and polypropylene.

20

9. A cartridge according to any of claims 1 to 8, wherein at least part of the pouch comprises one or more materials selected from the group consisting of: fleece, viscose, non-woven material, non-woven fleece, woven material, knitted material, nylon, and polyester.

25

10. A pouch for use with apparatus for heating smokable material to volatilise at least one component of the smokable material, the pouch comprising:
a first wall made of a first material; and
a second wall made of a second material that is a different material to the first material;

30

wherein the pouch contains smokable material between the first wall and the second wall.

11. A pouch according to claim 10, wherein the second wall is porous for permitting aerosol or volatilised material generated within the pouch to pass out of the pouch from

within the pouch, and the first wall is less porous to the aerosol or volatilised material than the second wall.

12. A pouch according to claim 10 or claim 11, wherein the smokable material
5 comprises an aerosol forming agent.
13. A method of manufacturing a pouch for use with apparatus for heating smokable material to volatilise at least one component of the smokable material, the method comprising:
10 providing a first wall made of a first material, and a second wall made of a second material that is a different material to the first material; and
attaching the first wall to the second wall with the smokable material between the first wall and the second wall.
14. A method according to claim 13, comprising depositing the smokable material
15 onto the second wall, and then attaching the first wall to the second wall with the smokable material between the first wall and the second wall.
15. A method according to claim 14, wherein the second wall defines a pocket, and
20 wherein the depositing comprises depositing the smokable material into the pocket.
16. A method according to claim 15, wherein the depositing comprises depositing the smokable material and aerosol containment material into the pocket.
17. A method according to any of claims 13 to 16, wherein the second wall is porous
25 for permitting aerosol or volatilised material generated within the pouch to pass out of the pouch from within the pouch, and the first wall is less porous to the aerosol or volatilised material than the second wall.
18. A method according to any one of claims 13 to 17, wherein the smokable
30 material comprises tobacco.

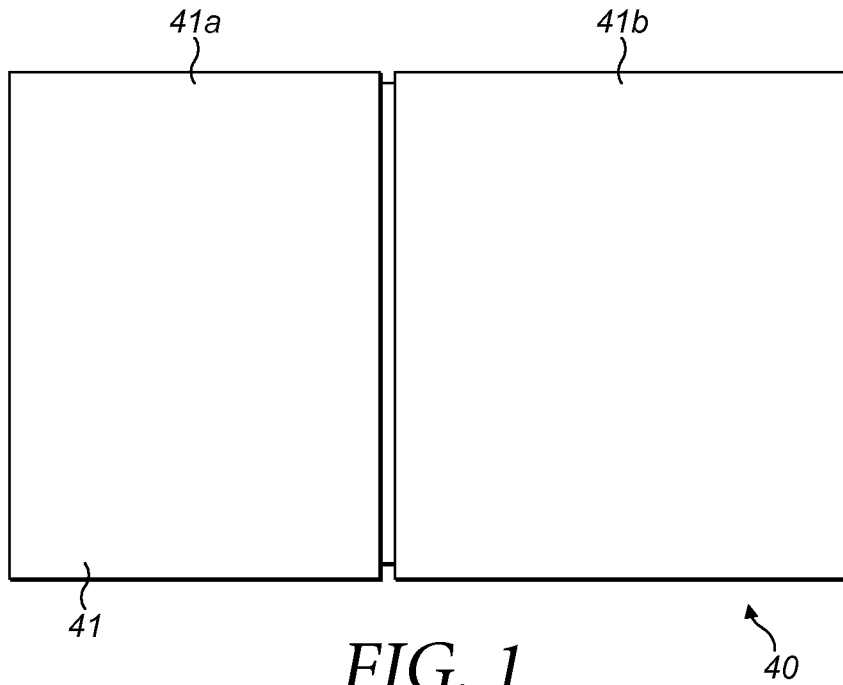

FIG. 1

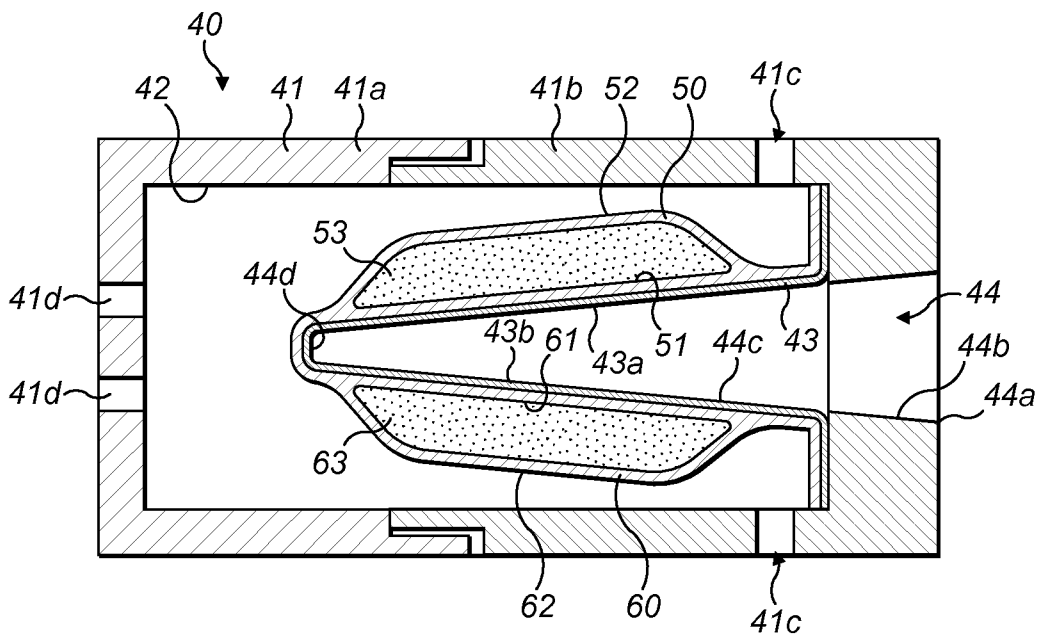

FIG. 2

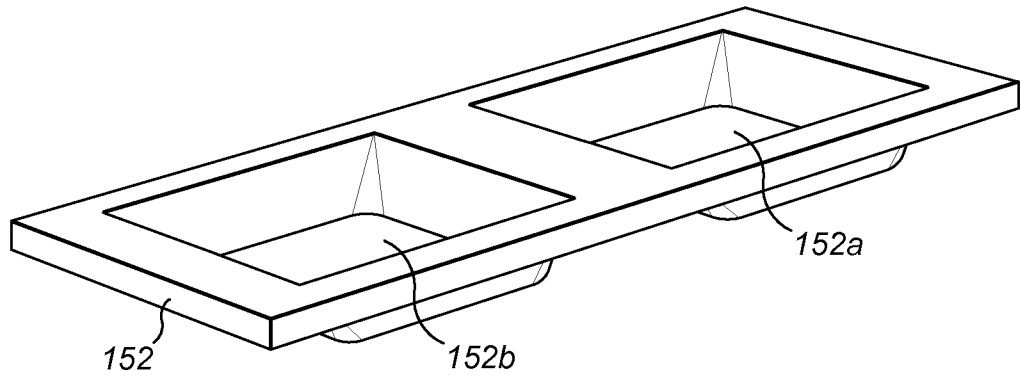

FIG. 3

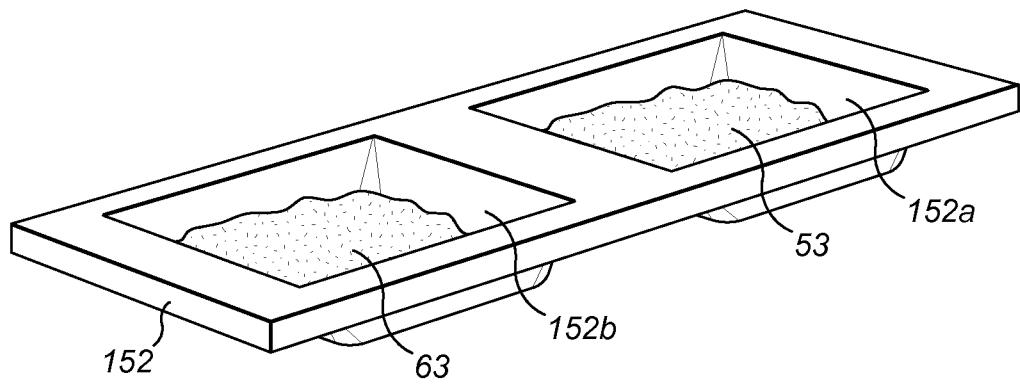

FIG. 4

3/4

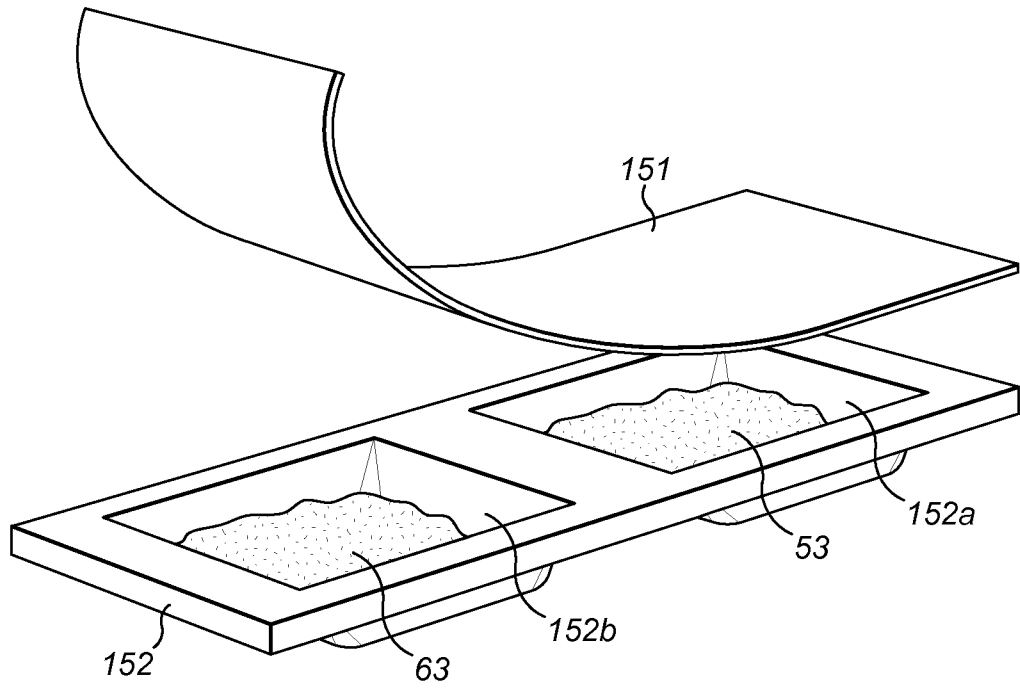

FIG. 5

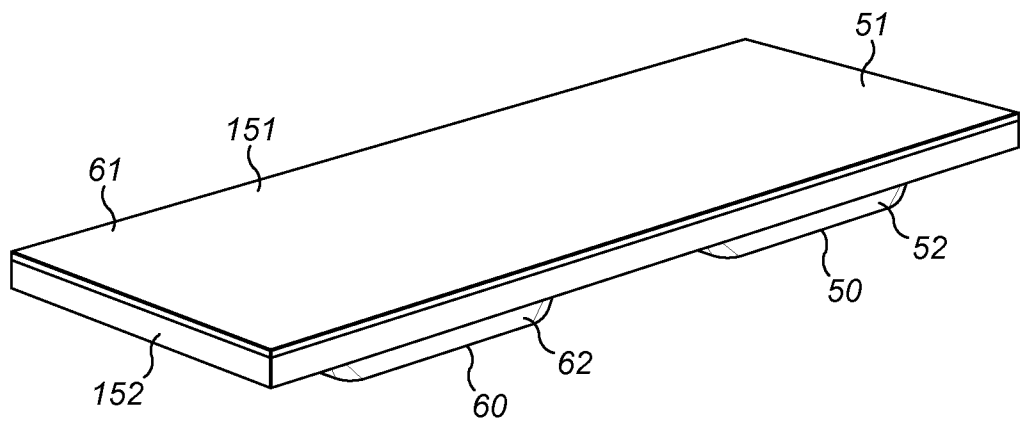

FIG. 6

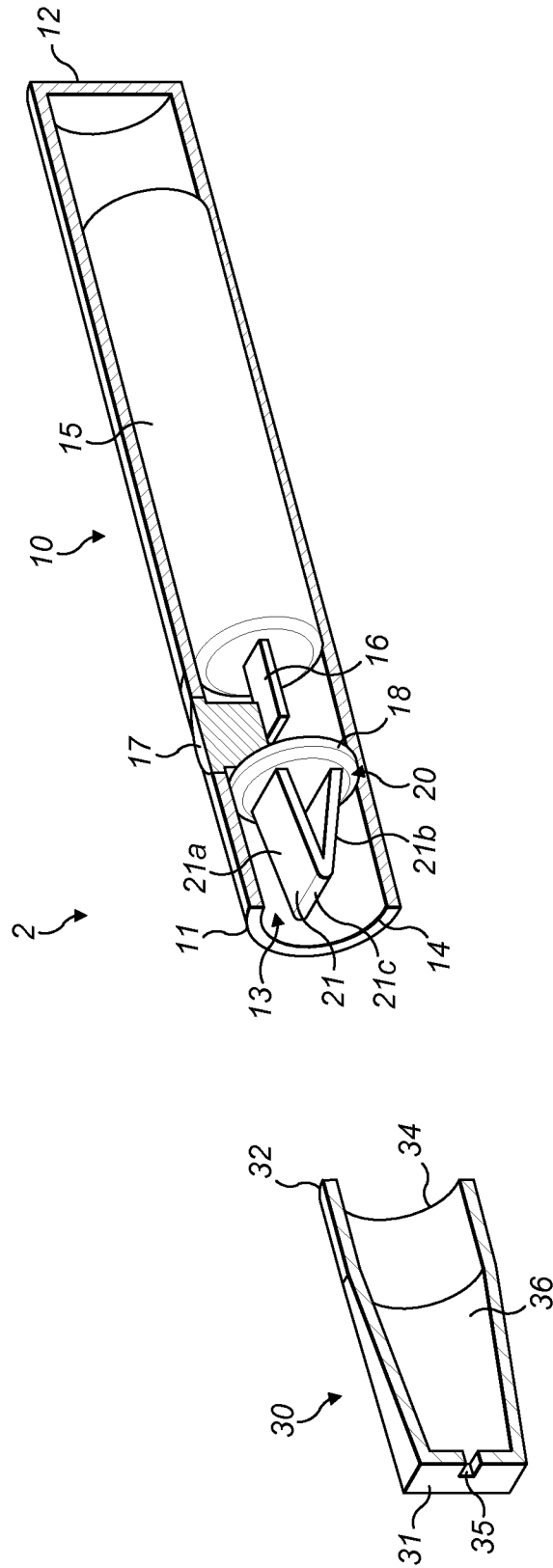

FIG. 7