



INTERNATIONAL APPLICATION PUBLISHED UNDER THE PATENT COOPERATION TREATY (PCT)

<p>(51) International Patent Classification ⁶ : B27N 1/02, B29B 13/02, B29C 45/02, 45/14, 45/22</p>	<p>A1</p>	<p>(11) International Publication Number: WO 99/56922 (43) International Publication Date: 11 November 1999 (11.11.99)</p>
--	-----------	---

<p>(21) International Application Number: PCT/US99/10078 (22) International Filing Date: 7 May 1999 (07.05.99) (30) Priority Data: 60/084,608 7 May 1998 (07.05.98) US (71) Applicant: CHASE-WALTON ELASTOMERS, INC. [US/US]; 29 Apsley Street, Hudson, MA 01749 (US). (72) Inventors: PRYCE, Timothy, D.; 68 Sleigh Road, Westford, MA 01886 (US). WALTON, Sean, M.; 4 Ridge Road, Hopkinton, MA 01748 (US). MORGAN, Donald, G.; 36 Plant Avenue, Hudson, MA 01749 (US). SIMKUS, A., Rooney; 4 Suzanne Drive, North Oxford, MA 01537 (US). (74) Agents: HJORTH, Beverly, E. et al.; Weingarten, Schurgin, Gagnebin & Hayes LLP, Ten Post Office Square, Boston, MA 02109 (US).</p>	<p>(81) Designated States: CA, MX. Published <i>With international search report.</i></p>
---	---

(54) Title: LIQUID INJECTION MOLDING PROCESS TO PRODUCE REINFORCED SILICONE RUBBER ARTICLES

(57) Abstract

A process for producing an article of reinforced silicone rubber utilizing a two-part liquid silicone rubber mixture (A, B). An open weave reinforcing fabric (46) is placed in a mold cavity (22) having the configuration of the article to be fabricated. The two-part liquid silicone rubber components (A, B) are mixed. A preselected amount of the mixture is fed into the mold cavity (22) to fill the mold cavity (22), surround the reinforcing fabric (46), and penetrate the spaces between the fabric fibers. The silicone rubber is allowed to cure, and the article is removed from the mold (30).

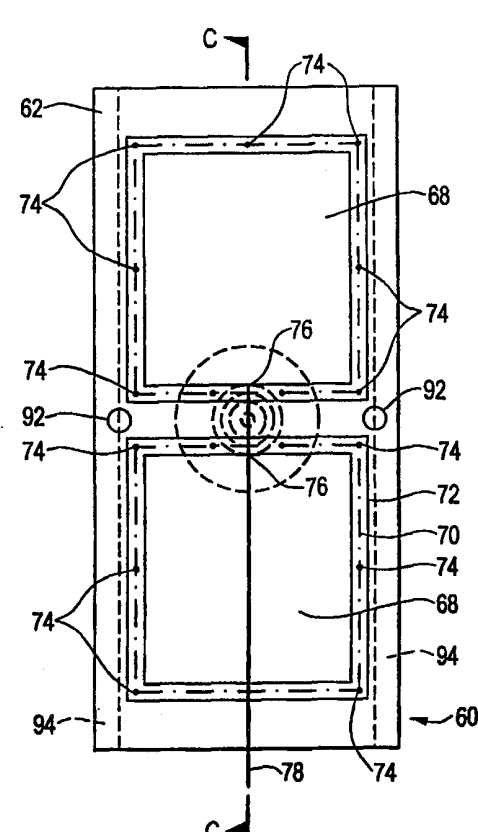

FOR THE PURPOSES OF INFORMATION ONLY

Codes used to identify States party to the PCT on the front pages of pamphlets publishing international applications under the PCT.

AL	Albania	ES	Spain	LS	Lesotho	SI	Slovenia
AM	Armenia	FI	Finland	LT	Lithuania	SK	Slovakia
AT	Austria	FR	France	LU	Luxembourg	SN	Senegal
AU	Australia	GA	Gabon	LV	Latvia	SZ	Swaziland
AZ	Azerbaijan	GB	United Kingdom	MC	Monaco	TD	Chad
BA	Bosnia and Herzegovina	GE	Georgia	MD	Republic of Moldova	TG	Togo
BB	Barbados	GH	Ghana	MG	Madagascar	TJ	Tajikistan
BE	Belgium	GN	Guinea	MK	The former Yugoslav Republic of Macedonia	TM	Turkmenistan
BF	Burkina Faso	GR	Greece			TR	Turkey
BG	Bulgaria	HU	Hungary	ML	Mali	TT	Trinidad and Tobago
BJ	Benin	IE	Ireland	MN	Mongolia	UA	Ukraine
BR	Brazil	IL	Israel	MR	Mauritania	UG	Uganda
BY	Belarus	IS	Iceland	MW	Malawi	US	United States of America
CA	Canada	IT	Italy	MX	Mexico	UZ	Uzbekistan
CF	Central African Republic	JP	Japan	NE	Niger	VN	Viet Nam
CG	Congo	KE	Kenya	NL	Netherlands	YU	Yugoslavia
CH	Switzerland	KG	Kyrgyzstan	NO	Norway	ZW	Zimbabwe
CI	Côte d'Ivoire	KP	Democratic People's Republic of Korea	NZ	New Zealand		
CM	Cameroon			PL	Poland		
CN	China	KR	Republic of Korea	PT	Portugal		
CU	Cuba	KZ	Kazakstan	RO	Romania		
CZ	Czech Republic	LC	Saint Lucia	RU	Russian Federation		
DE	Germany	LI	Liechtenstein	SD	Sudan		
DK	Denmark	LK	Sri Lanka	SE	Sweden		
EE	Estonia	LR	Liberia	SG	Singapore		

TITLE OF THE INVENTION

Liquid Injection Molding Process to Produce
Reinforced Silicone Rubber Articles

5

CROSS REFERENCE TO RELATED APPLICATIONS

This application claims the benefit under 35 U.S.C.
§ 119(e) of U.S. Provisional Application No. 60/084,608,
filed on May 7, 1998, the disclosure of which is
incorporated by reference herein.

10

STATEMENT REGARDING FEDERALLY SPONSORED RESEARCH OR
DEVELOPMENT

Not Applicable

15

BACKGROUND OF THE INVENTION

Silicone rubber articles such as hoses, sheets, and
seals, are often reinforced with a fabric mesh in a multi-
step process requiring manual steps and experienced
personnel. In making a silicone rubber reinforced hose by
conventional techniques, a fabric mesh is wrapped around a
cylindrical mandrel and uncured silicone rubber is wrapped
around the mesh. The rubber is then cured by heating, and
during the curing process the mesh becomes embedded within
the cured rubber wall. Such a manual process is time
consuming, requires experienced personnel for effective
fabrication, and is expensive because of the human labor
required.

20

25

Liquid injection molding (LIM) is a known process for
fabricating articles from silicone and other rubber
materials. With this process, two liquid components of a
silicone rubber are mixed and injected into a heated mold.
The mixture cures in the mold to produce a finished
article.

30

35

BRIEF SUMMARY OF THE INVENTION

The present invention relates to a process for producing an article of reinforced silicone rubber and an article produced by the process of the invention. According to the present process, a mold is provided having a mold cavity therein of the appropriate configuration to form the desired finished article, such as a hose or a sheet. A reinforcing fabric is placed within the mold cavity. At least a portion of the edge of the fabric is fastened to the perimeter of the mold cavity adjacent the entry point for the liquid silicone rubber mixture.

First and second components of a silicone rubber are provided in first and second reservoirs respectively. Each component is liquid at room temperature. The first component includes a catalyst therein to cause the components to cure upon mixing. The second component includes a cure inhibiting agent therein selected to slow the cure rate of the silicone rubber until a mixture of the first and second components have filled the mold cavity.

The first and second components are then mixed. A preselected amount of the mixture is fed into the mold cavity to fill the mold cavity and surround and penetrate the reinforcing fabric. The silicone rubber is allowed to cure, and the article is removed from the mold.

The reinforcing fabric is an open weave fabric having a sufficient stiffness to retain its shape within the mold cavity. The silicone rubber mixture flows along both sides of the fabric and through the spaces between the warp and weft fibers of the fabric, thereby embedding the fabric in the silicone rubber upon curing.

5

10

15

20

25

30

35

DESCRIPTION OF THE DRAWINGS

The invention will be more fully understood from the following detailed description taken in conjunction with the accompanying drawings in which:

5 Fig. 1 is a schematic illustration of the injection molding process of the present invention;

Fig. 2 is a side view of a mold for producing a reinforced silicone rubber hose according to the present invention;

10 Fig. 3 is an end view of the mold of Fig. 2;

Fig. 4 is a cross-sectional view along line A-A of Fig. 3;

Fig. 5 is a side view of a mold for producing a reinforced silicone rubber sheet according to the present invention;

15 Fig. 6 is a cross-sectional view along line B-B of Fig. 5;

Fig. 7 is a cross-sectional view along line C-C of Fig. 6; and

20 Fig. 8 is an enlarged view of area D indicated in dotted lines in Fig. 7.

DETAILED DESCRIPTION OF THE INVENTION

Referring to Fig. 1, the silicone rubber for producing a reinforced article according to the present invention is supplied in two parts 10, 12, components A and B. Each component is a liquid at room temperature. One component contains a catalyst and the other component contains an inhibiting agent. Upon mixing, the catalyst causes the components to react and cure to form a solid silicone rubber. The inhibiting agent acts to slow the reaction sufficiently to allow the mixture to reach and fill the mold before curing to a solid.

30 Liquid silicone rubber components are commercially available from a number of silicone suppliers, such as

35

General Electric, Dow Corning, or Wacker. The particular silicone is selected based on the desired hardness of the article upon curing, the desired cure rate, and the viscosity of the mixture of the components prior to curing.

5 The viscosity should be chosen to provide good flow through the mold runner system and mold cavity to ensure that the mold cavity is properly filled. A viscosity of 375,000 centipoise has been found to be satisfactory.

10 The components are pumped from their respective reservoirs into a mixer 14. Additives 16 such as a coloring agent may be mixed in if desired as well, as is known in the art. A static mixer is suitable, although other mixers may be used if desired. The mixture is then fed under pressure to an injection barrel or reservoir 18. From the
15 barrel, the mixture is injected into the runner system of a mold 20 and into the mold cavity 22. The mold cavity has a configuration of the article to be manufactured.

20 Figs. 2 through 4 illustrate a mold 30 for producing a reinforced hose. The mold illustrated forms a hose with three ribs, although no or any other number of ribs may be provided if desired. The mold is formed in two halves 32, 34 separated by a parting line 36 and has a cylindrical cavity 38 formed therein. The cylindrical cavity has two end sections 40, 42 with slightly narrowed diameters. A
25 cylindrical mandrel 44 is also provided in the cavity. The mandrel extends into the narrowed end sections of the cavity and is clamped therein by closure of the mold to retain the mandrel centered in the cylindrical cavity. A guide pin (not shown) may also be provided to center and
30 fix the mandrel in the mold cavity.

Prior to feeding the mixture into the mold, multiple plies of reinforcing fabric 46 are cut, on a bias, to the appropriate size and formed around the mandrel. At least one edge 48 of the fabric is clamped between the cavity
35 wall and the mandrel 44. The other edge 50 of the fabric

may remain free from clamping. The fabric is cut on the bias to achieve the desired pressure rating of the finished hose and to ease removal of the finished hose from the mandrel.

5 The reinforcing fabric 46 may be any desired material, such as cotton, fiberglass, polyester, or nylon, such as NOMEX or KEVLAR, as is known in the art. The fabric may be woven, knit, or braided with open spaces between the fibers to allow the liquid silicone rubber mixture to flow through
10 the spaces. The mixture also flows along both sides of the length of the fabric. By surrounding and penetrating the fabric, a good bond is provided between the fabric and the silicone rubber upon curing. The fabric also has a sufficient stiffness to provide a degree of rigidity so
15 that it retains its shape and does not collapse against the mandrel. A suitable stiffness can be achieved by a sufficient amount of sizing on the fabric.

 With the fabric 46 and mandrel 40 clamped in place and the mold closed, the mixture is injected into the mold
20 through an entry or injection point 52. Air in the mold is vented out through suitable vent ports. The mold parting line 36 may serve as a vent port. The injection point is located near the edge 48 of the fabric 46 that is clamped to the mold. In this way, the mixture flows along the
25 length of the cavity 38 from the clamped edge 48 toward the free edge 50 of the fabric. The flow of the silicone mixture aids in holding the fabric in place spaced from the cavity walls, so that the fabric is embedded generally in the middle of the finished article. The fabric is chosen to
30 match the viscosity of the mixture. The more viscous the mixture is, the more open the weave or the spaces between the fibers should be. Additionally, if multiple injection points are provided in the mold, each injection point should be located at an edge of the fabric that is clamped
35 to the mold.

After curing, the mold is opened and the cured article removed from the mold cavity. The article is taken off the mandrel. Suitable mechanical strippers or air hoses (not shown) may be used if necessary, as known in the art.

5 The mold adjacent to the cavity is maintained at a temperature of at least approximately 300°F in any manner known in the art. The mandrel and runner system of the mold are not purposely heated, although the mandrel in particular heats up during the molding process. The mandrel
10 is preferably cooled after each cycle by, for example, immersion in a cool fluid such as water after removing the mandrel from the cured hose. The mandrel can be cooled in any other manner known in the art, such as by flow of a cooling fluid through channels therein, if desired.

15 Figs. 5 through 8 illustrate a mold 60 for fabricating a reinforced silicone rubber sheet. The mold is formed from two halves 62, 64 separated by a parting line 66 and has a square or rectangular cavity 68 of small thickness formed therein. (See Figs. 6 and 8) In the particular mold
20 illustrated, two square mold cavities are illustrated, each for fabricating a 6-inch by 6-inch sheet having a thickness of 0.060 inch. It will be appreciated, however, that any desired number of cavities may be provided.

25 The fabric may be attached to the mold in any suitable manner. For example, in the embodiment shown, each cavity 68 includes a lip 70 of reduced thickness surrounding the perimeter 72 of the cavity. Pins 74 extend upwardly from one half 62 of the mold along the lip 70 and fit into corresponding apertures in the other half of the mold. The
30 fabric is placed in the mold with one, several, or all edges of the fabric overlapping the lip and the pins protruding through the fabric. When the mold is closed, the pins fit into the corresponding apertures, thereby fastening the fabric to the mold. At least the edge of the
35 fabric adjacent the injection point 76 is fastened to the

mold.

In the embodiment illustrated, a runner 78 brings the liquid silicone rubber mixture to a sprue 80 and chamber 82 located between the two cavities. A well 84 may also be provided below the sprue and chamber for receiving the mixture. Narrow ducts 86 lead from the chamber 82 into the two mold cavities. Air is vented through the parting line 66 or other vent ports. The mold may include heating rods or channels 88 for a heated fluid to heat the mold to a suitable temperature, such as at least approximately 300°F. One or more thermocouples may also be placed in openings 90 in the mold to monitor the temperature, as is known in the art. Guide pins 92 may be provided to align the two mold halves 62, 64. The mold halves may also include opposed lips 94 for receiving a clamping device (not shown) to retain the molds tightly closed during the injection and curing steps.

With this process, the article can be made with little or no flashing by controlling the amount of the liquid silicone rubber mixture that is injected into the mold cavity. In the preferred embodiment, the injection barrel 18 includes a volume sensor 96 such that the amount of the mixture in the barrel can be determined and controlled. For example, when the desired volume of mixture has entered the injection barrel, a valve 98 may be closed to prevent any further mixture from flowing in. The valve can be operated automatically or manually, as desired. Other ways of measuring the amount of mixture, such as a flow meter in the line to the barrel, may be used, as will be appreciated by those in the art. In this manner, the amount of mixture allowed into the mold is precisely the amount needed to fill the mold cavity to form the article with substantially no flash to be removed from the article after removal from the mold.

The present process has been used satisfactorily to

fabricate reinforced silicone rubber hoses having a diameter of from 2.5 inches to 4 inches and a length of 9 inches. Such articles have a cycle time of less than 15 minutes and typically of 5 to 10 minutes. Reinforced
5 silicone sheets having a width of 6 inches, a length of 6 inches, and a thickness of 0.060 inch have also been satisfactorily made. It will be appreciated that articles having different dimensions and configurations from those specifically illustrated and described herein may be
10 fabricated by the presently claimed process.

The invention is not to be limited by what has been particularly shown and described, except as indicated by the appended claims.

CLAIMS

We claim:

1. A process for producing a article of reinforced
5 silicone rubber, comprising:

providing a mold having a mold cavity therein;

placing a reinforcing fabric within the mold cavity;

10 providing a first component of a silicone rubber in a first reservoir, the first component being liquid at room temperature and including a catalyst therein, and a second component of the silicone rubber in a second reservoir, the second component being liquid at room temperature and including a cure inhibiting agent therein selected to slow the cure rate of the silicone rubber until a mixture of the
15 first and second components have filled the mold cavity;

mixing the first component and the second component to form the mixture;

20 filling the mold cavity and surrounding the reinforcing fabric with a preselected amount of the mixture;

allowing the silicone rubber to cure; and
removing the article from the mold.

2. The process of claim 1, further comprising fastening
25 at least a portion of an edge of the reinforcing fabric to a perimeter portion of the mold cavity.

3. The process of claim 1, further comprising fastening
30 at least a portion of an edge of the reinforcing fabric to a perimeter portion of the mold cavity adjacent an entry point into the mold and filling the mold cavity with the mixture through the entry point.

4. The process of claim 1, wherein the reinforcing fabric
35 is clamped along at least a portion of the perimeter of the

mold cavity.

5 5. The process of claim 1, wherein the reinforcing fabric is pinned along at least a portion of the perimeter of the mold cavity.

10 6. The process of claim 1, wherein the reinforcing fabric comprises an open weave fabric and in the step of filling the mold and surrounding the reinforcing fabric, the mixture flows through spaces in the reinforcing fabric and along both sides of the fabric.

15 7. The process of claim 1, wherein the reinforcing fabric is sufficiently stiff to retain a shape in the mold.

8. The process of claim 7, wherein the stiffness of the reinforcing fabric is provided by a suitable amount of sizing on the fabric.

20 9. The process of claim 1, wherein the fabric comprises cotton, fiberglass, polyester, or nylon.

25 10. The process of claim 1, wherein the fabric comprises a woven, knit, or braided material.

11. The process of claim 1, further comprising venting the mold cavity through a vent port during the step of filling the mold.

30 12. The process of claim 1, further comprising venting the mold cavity through a parting line that separates the mold.

35 13. The process of claim 1, further comprising heating the mold.

14. The process of claim 13, further comprising heating the mold to at least approximately 300°F.

5 15. The process of claim 1, further comprising feeding the mixture after the mixing step to a reservoir, measuring the amount of the mixture in the reservoir, and stopping the feed of the mixture to the reservoir after the preselected amount of the mixture has been fed into the reservoir.

10 16. The process of claim 15, further comprising measuring the volume of the mixture in the reservoir with a volume sensor.

15 17. The process of claim 1, wherein the preselected amount of the mixture is selected to fill the mold cavity to form the article with substantially no flash to be removed after curing.

20 18. The process of claim 1, wherein the mixture has a viscosity selected to enable the mixture to flow through spaces in the reinforcing fabric and along both sides of the fabric and to fill the mold cavity.

25 19. The process of claim 1, wherein the mixture has a viscosity of 375,000 centipoise.

30 20. The process of claim 1, wherein the mold cavity is cylindrical and a mandrel is provided in the cavity to form a hose-shaped cavity.

21. The process of claim 20, wherein the mandrel is fixed to the mold along a perimeter of the mold cavity.

35 22. The process of claim 1, wherein the mold cavity is

rectangular to form a sheet-shaped cavity.

23. A reinforced silicone rubber article formed by the process of claim 1.

5

24. The reinforced silicone rubber article of claim 23, wherein the article comprises a reinforced hose.

10

25. The reinforced silicone rubber article of claim 23, wherein the article comprises a reinforced sheet.

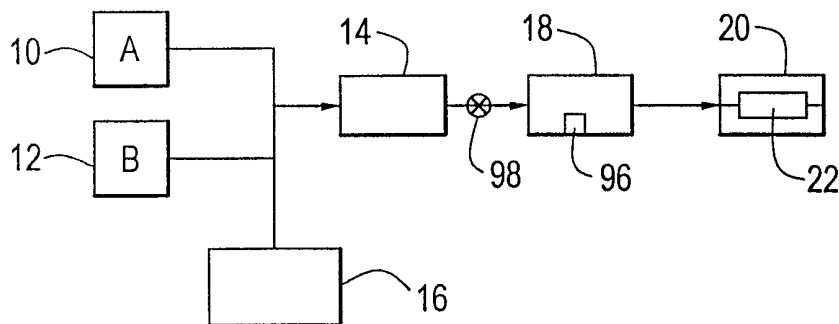

FIG. 1

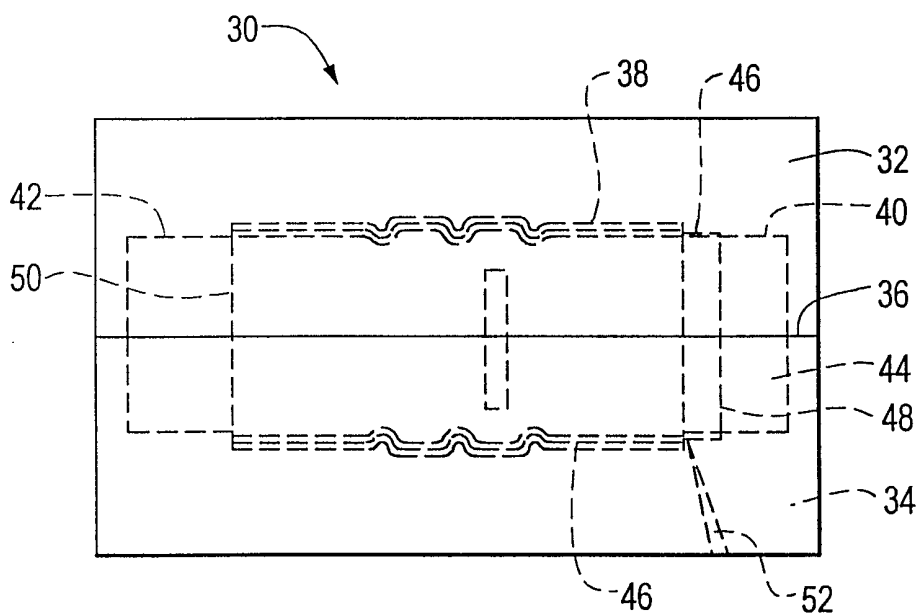

FIG. 2

2/4

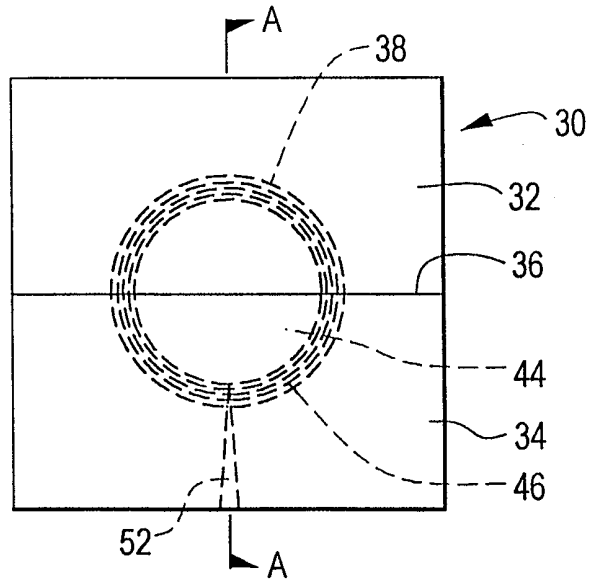

FIG. 3

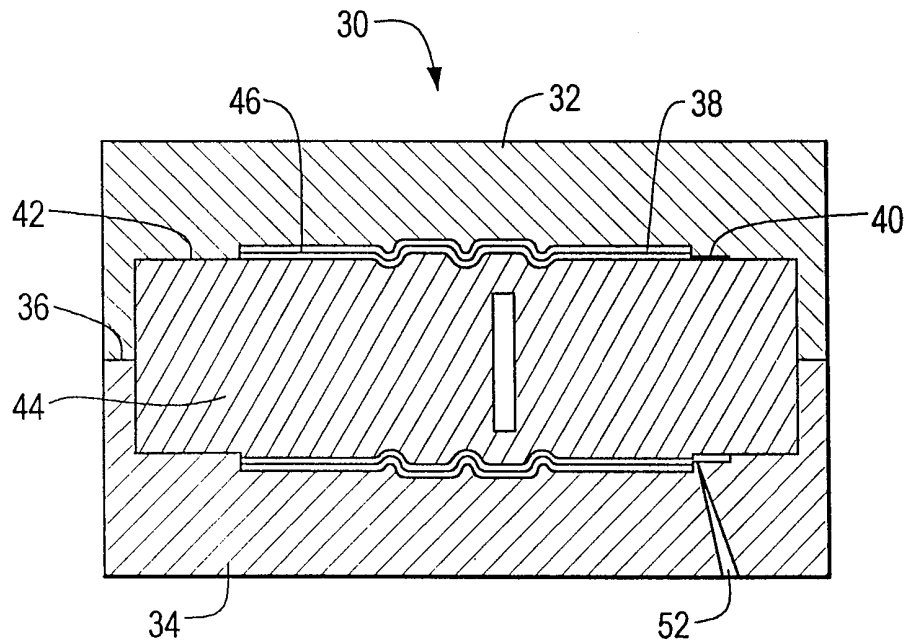

FIG. 4

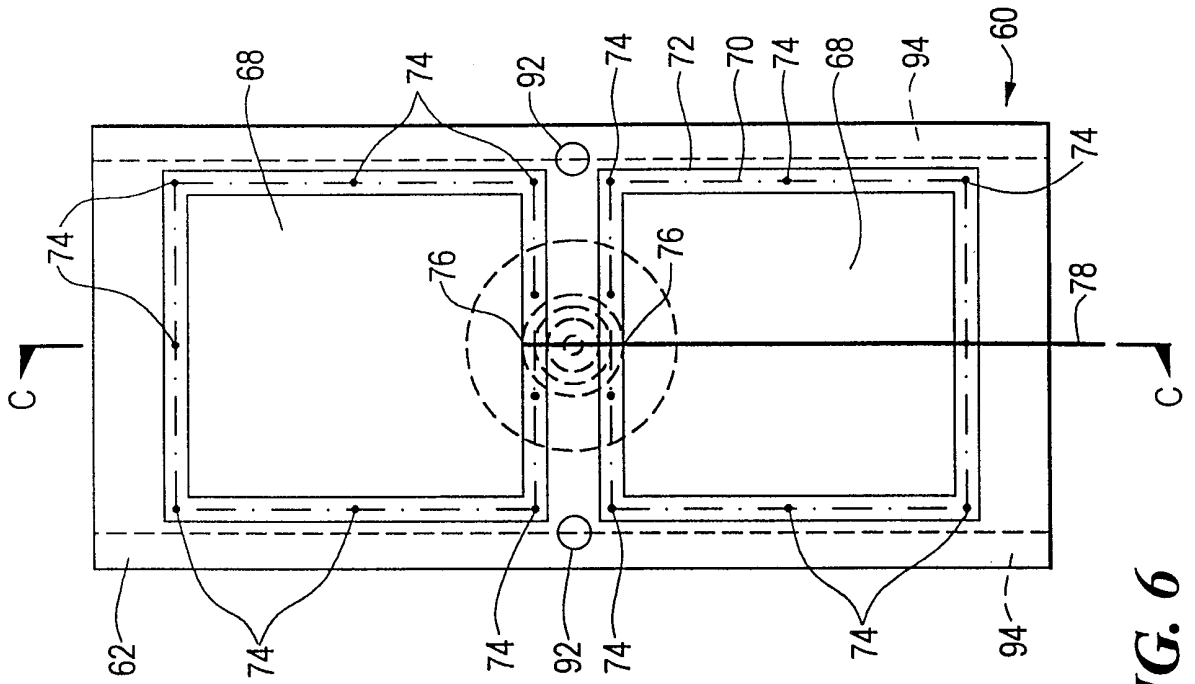

FIG. 5

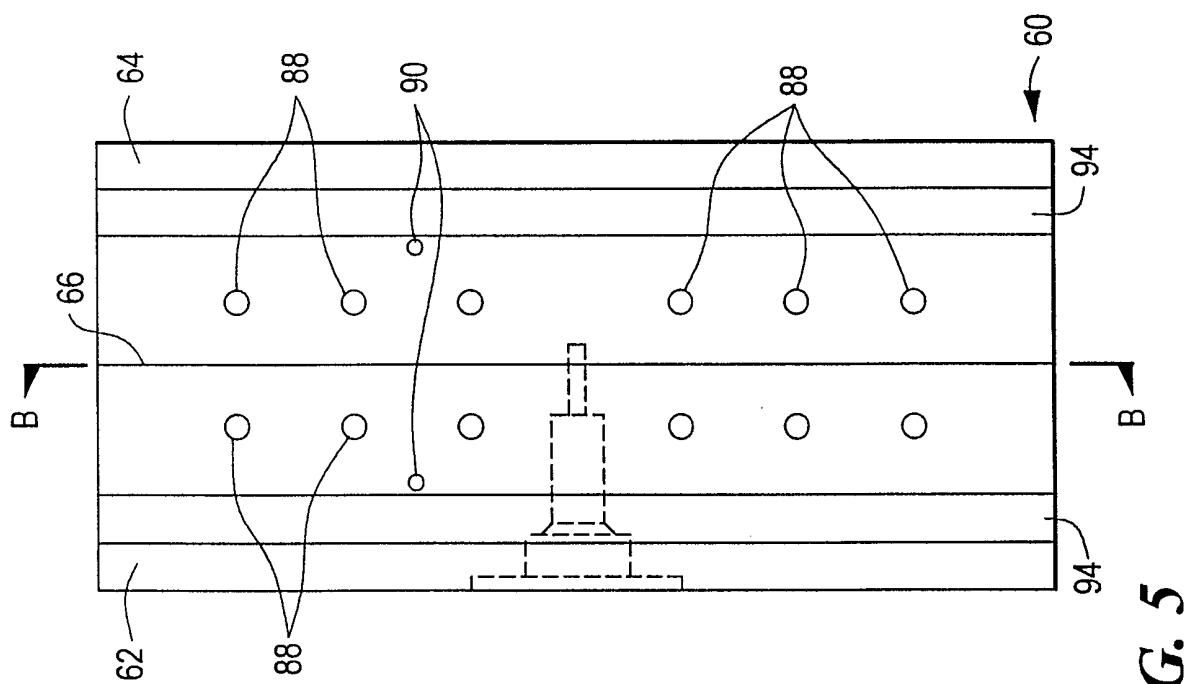

FIG. 6

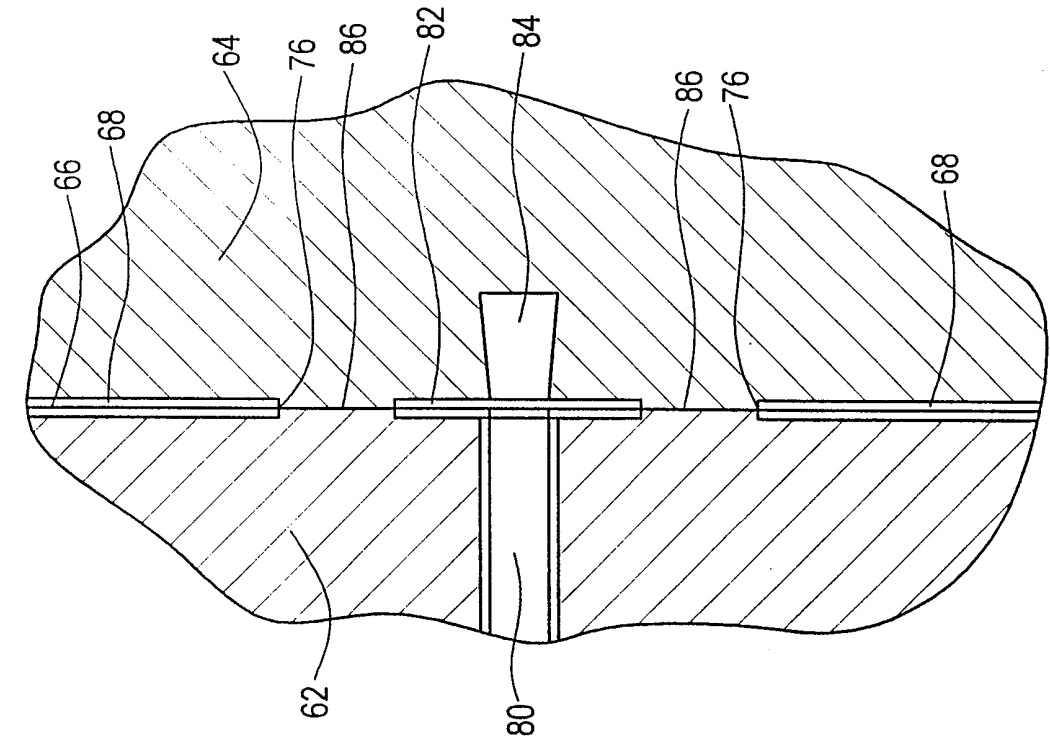

FIG. 7

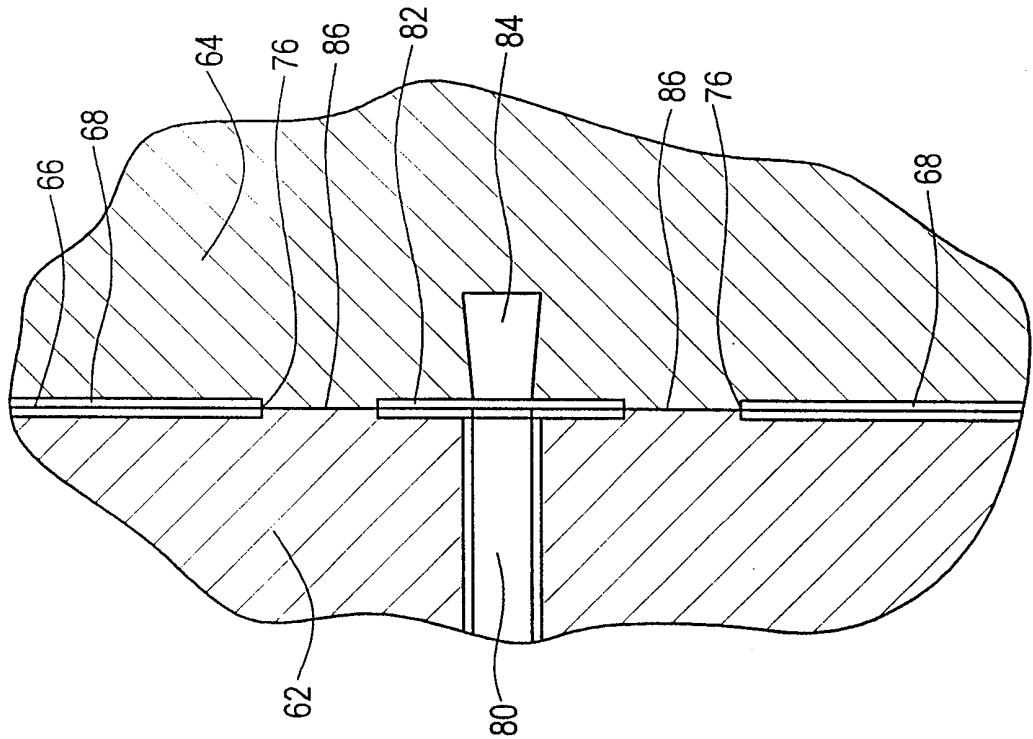

FIG. 8

INTERNATIONAL SEARCH REPORT

International application No.
PCT/US99/10078

A. CLASSIFICATION OF SUBJECT MATTER

IPC(6) :B27N 1/02; B29B 13/02; B29C 45/02, 45/14, 45/22
US CL :Please See Extra Sheet.

According to International Patent Classification (IPC) or to both national classification and IPC

B. FIELDS SEARCHED

Minimum documentation searched (classification system followed by classification symbols)

U.S. : 264/257, 258, 102, 328.6, 328.8, 328.9, 328.12, 328.16, 328.17, 328.18, 274, 271.1, 275, 276, 279.1

Documentation searched other than minimum documentation to the extent that such documents are included in the fields searched

Electronic data base consulted during the international search (name of data base and, where practicable, search terms used)

C. DOCUMENTS CONSIDERED TO BE RELEVANT

Category*	Citation of document, with indication, where appropriate, of the relevant passages	Relevant to claim No.
Y	US 3,107,234 A (STEWART) 15 October 1963, see entire document.	1-25
Y	US 3,417,175 A (BROWN et al) 17 December 1968, see entire document.	1-25
Y	US 4,370,123 A (DANNELS et al) 25 January 1983, see entire document.	1-25
Y	US 4,340,709 A (JERAM et al) 20 July 1982, see entire document.	1-25
Y	US 4,442,055 A (OELSCH et al) 10 April 1984, see entire document.	1-25
Y	US 4,442,060 A (BOUVEROT et al) 10 April 1984, see entire document.	1-25

Further documents are listed in the continuation of Box C. See patent family annex.

* Special categories of cited documents:	*T	later document published after the international filing date or priority date and not in conflict with the application but cited to understand the principle or theory underlying the invention
A document defining the general state of the art which is not considered to be of particular relevance	*X*	document of particular relevance; the claimed invention cannot be considered novel or cannot be considered to involve an inventive step when the document is taken alone
B earlier document published on or after the international filing date	*Y*	document of particular relevance; the claimed invention cannot be considered to involve an inventive step when the document is combined with one or more other such documents, such combination being obvious to a person skilled in the art
L document which may throw doubts on priority claim(s) or which is cited to establish the publication date of another citation or other special reason (as specified)	*&*	document member of the same patent family
O document referring to an oral disclosure, use, exhibition or other means		
P document published prior to the international filing date but later than the priority date claimed		

Date of the actual completion of the international search 16 JULY 1999	Date of mailing of the international search report 02 AUG 1999
Name and mailing address of the ISA/US Commissioner of Patents and Trademarks Box PCT Washington, D.C. 20231 Facsimile No. (703) 305-3230	Authorized officer <i>B. J. Gray</i> ROBIN GRAY Telephone No. (703) 308-0661

INTERNATIONAL SEARCH REPORT

International application No.

PCT/US99/10078

C (Continuation). DOCUMENTS CONSIDERED TO BE RELEVANT		
Category*	Citation of document, with indication, where appropriate, of the relevant passages	Relevant to claim No.
Y	US 4,457,887 A (PORSCHE) 03 July 1984, see entire document.	1-25
Y	US 4,472,341 A (ALBERINO et al) 18 September 1984, see entire document.	1-25
Y	US 4,528,354 A (MCDOUGAL) 09 July 1985, see entire document.	1-25
Y	US 4,546,154 A (ROBERTSON) 08 October 1985, see entire document.	1-25
Y	US 4,732,724 A (STERNER) 22 March 1988, see entire document.	1-25
Y	US 4,806,391 A (SHORIN) 21 February 1989, see entire document.	1-25
Y	US 4,818,829 A (NOPPER et al) 04 April 1989, see entire document.	1-25
Y	US 4,940,563 A (KROMREY) 10 July 1990, see entire document.	1-25
Y	US 5,093,067 A (GIBSON) 03 March 1992, see entire document.	1-25
Y	US 5,309,840 A (TAKAMURA et al.) 10 May 1994, see entire document.	1-25

INTERNATIONAL SEARCH REPORT

International application No.
PCT/US99/10078

A. CLASSIFICATION OF SUBJECT MATTER:

US CL :

264/257, 258, 102, 328.6, 328.8, 328.9, 328.12, 328.16, 328.17, 328.18, 274, 271.1, 275, 276, 279.1