



- (51) International Patent Classification:  
H01L 31/052 (2006.01) E04D 13/03 (2006.01)  
H01L 31/048 (2006.01)
- (21) International Application Number:  
PCT/US2013/040695
- (22) International Filing Date:  
13 May 2013 (13.05.2013)
- (25) Filing Language: English
- (26) Publication Language: English
- (30) Priority Data:  
13/477,400 22 May 2012 (22.05.2012) US
- (71) Applicant: GUARDIAN INDUSTRIES CORP.  
[US/US]; 2300 Harmon Road, Auburn Hills, MI 48326-1714 (US).
- (72) Inventors: DEN BOER, Willem; 9184 Lanning Lane, Brighton, MI 48116 (US). VEERASAMY, Vijayen, S.; 756 Eagle Road, Ann Arbor, MI 48103 (US).
- (74) Agent: RHAO, Joseph, A.; Nixon & Vanderhye P.C., 901 North Glebe Road, 11th Floor, Arlington, VA 22203-1808 (US).
- (81) Designated States (unless otherwise indicated, for every kind of national protection available): AE, AG, AL, AM,

AO, AT, AU, AZ, BA, BB, BG, BH, BN, BR, BW, BY, BZ, CA, CH, CL, CN, CO, CR, CU, CZ, DE, DK, DM, DO, DZ, EC, EE, EG, ES, FI, GB, GD, GE, GH, GM, GT, HN, HR, HU, ID, IL, IN, IS, JP, KE, KG, KM, KN, KP, KR, KZ, LA, LC, LK, LR, LS, LT, LU, LY, MA, MD, ME, MG, MK, MN, MW, MX, MY, MZ, NA, NG, NI, NO, NZ, OM, PA, PE, PG, PH, PL, PT, QA, RO, RS, RU, RW, SC, SD, SE, SG, SK, SL, SM, ST, SV, SY, TH, TJ, TM, TN, TR, TT, TZ, UA, UG, US, UZ, VC, VN, ZA, ZM, ZW.

- (84) Designated States (unless otherwise indicated, for every kind of regional protection available): ARIPO (BW, GH, GM, KE, LR, LS, MW, MZ, NA, RW, SD, SL, SZ, TZ, UG, ZM, ZW), Eurasian (AM, AZ, BY, KG, KZ, RU, TJ, TM), European (AL, AT, BE, BG, CH, CY, CZ, DE, DK, EE, ES, FI, FR, GB, GR, HR, HU, IE, IS, IT, LT, LU, LV, MC, MK, MT, NL, NO, PL, PT, RO, RS, SE, SI, SK, SM, TR), OAPI (BF, BJ, CF, CG, CI, CM, GA, GN, GQ, GW, ML, MR, NE, SN, TD, TG).

**Published:**

- with international search report (Art. 21(3))
- before the expiration of the time limit for amending the claims and to be republished in the event of receipt of amendments (Rule 48.2(h))

(54) Title: MULTI-FUNCTIONAL PHOTOVOLTAIC SKYLIGHT AND/OR METHODS OF MAKING THE SAME

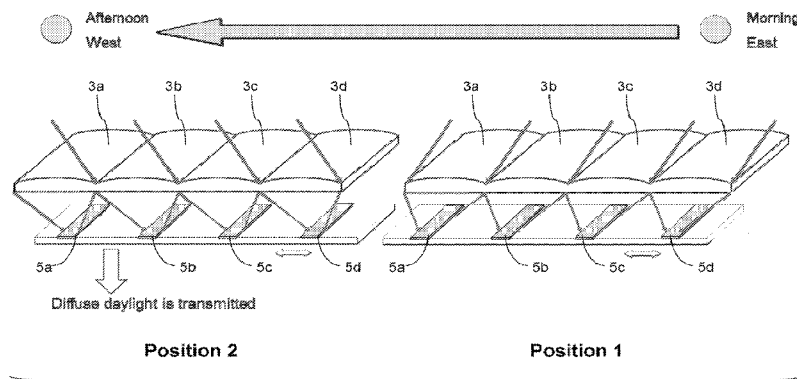
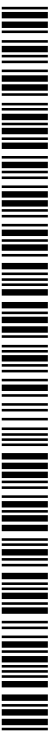

Fig. 11

(57) Abstract: Certain examples relate to improved solar photovoltaic systems, and/or methods of making the same. Certain improved building-integrated photovoltaic systems may include concentrated photovoltaic skylights having a cylindrical lens array. The skylight may include an insulated glass unit, which may improve the solar heat gain coefficient. The photovoltaic skylight and lens arrays may be used in combination with strip solar cells and lateral displacement tracking systems. Such techniques may advantageously help to reduce cost per watt related, in part, to the potentially reduced amount of semiconductor material to be used for such example embodiments. A photovoltaic skylight may permit diffuse daylight to pass through into an interior of a building so as to provide lighting inside the building, while the strip solar cells absorb the direct sunlight and convert it to electricity.



## TITLE OF THE INVENTION

MULTI-FUNCTIONAL PHOTOVOLTAIC SKYLIGHT AND/OR  
METHODS OF MAKING THE SAME

## CROSS-REFERENCES TO RELATED APPLICATIONS

**[0001]** This application is a continuation-in-part of U.S. Application Serial No. 12/662,624 filed April 26, 2010 entitled "Patterned Glass Cylindrical Lens Arrays for Concentrated Photovoltaic Systems, and/or Methods of Making the Same."

## FIELD OF THE INVENTION

**[0002]** Certain example embodiments of this invention relate to improved solar photovoltaic systems, and/or methods of making the same. More particularly, certain example embodiments of this invention relate to building-integrated photovoltaic systems including concentrated photovoltaic skylights having a cylindrical lens array, and/or methods of making the same. In certain example embodiments, the photovoltaic skylight and lens arrays may be used in combination with strip solar cells and lateral displacement tracking. Such techniques may advantageously help to reduce cost per watt related, in part, to the potentially reduced amount of semiconductor material to be used for such example embodiments. Furthermore, a photovoltaic skylight may permit diffuse daylight to pass through into an interior of a building so as to provide lighting inside the building, while the strip solar cells absorb the direct sunlight and convert it to electricity. In addition, the photovoltaic skylight may provide variable solar heat gain control.

## BACKGROUND AND SUMMARY OF EXAMPLE EMBODIMENTS OF THE INVENTION

**[0003]** Photovoltaic devices are known in the art (e.g., see U.S. Patent Nos. 6,784,361, 6,288,325, 6,613,603, and 6,123,824, the disclosures of which are hereby incorporated herein by reference). Some conventional mainstream photovoltaic modules use a large number of crystalline silicon (c-Si) wafers. The inclusion of the large number of c-Si wafers tends to dominate the cost of the overall photovoltaic module. Indeed, about 60% of the costs involved in the production of conventional photovoltaic modules is related to the c-Si solar cells. To address this issue, concentrated photovoltaic (CPV) systems have been proposed, in which the sunlight is to be focused with concentration ratios of 100x to 1000x. Calculations suggest that a concentration ratio of approximately 10x should enable a photovoltaic system to be produced that uses at least 90% less silicon material.

**[0004]** Unfortunately, however, current concentrated photovoltaic systems use expensive high efficiency multi-junction solar cells, expensive dual-axis tracking systems, and/or relatively expensive concentrating optics. Therefore, these systems have difficulty competing with other photovoltaic solutions on a cost per watt basis.

**[0005]** Thus, it will be appreciated there is a need in the art for a simple low-cost CPV systems, together with low cost solar cells and low-cost concentrating optics, and/or methods of making the same.

**[0006]** One aspect of certain example embodiments relates to a patterned glass cylindrical lens array, and/or methods of making the same.

**[0007]** Another aspect of certain example embodiments relates to using such a cylindrical lens array to focus light on substantially elongate or strip solar cells.

[0008] Another aspect of certain example embodiments relates to lateral displacement tracking systems, and/or methods of making and/or using the same.

[0009] Further aspects of certain example embodiments relate to building-integrated photovoltaic systems, which may include insulating glass units comprising cylindrical lens arrays and strip solar cells. In certain examples, the photovoltaic system may be integrated into a building as an insulated glass skylight.

[0010] According to certain example embodiments, lateral tracking of a solar cell strip substrate relative to a lenticular array that concentrates light thereon advantageously results in cost-effective electricity generation, self-regulated solar heat gain control, and diffuse daylight entry, thereby providing a multifunctional BIPV product. The concentration ratio preferably is at least 2:1, more preferably at least about 3:1, although high concentration ratios are possible. In some instances, heat sinks may be provided to keep the assembly cool, e.g., when high concentration ratios are provided.

[0011] According to certain example embodiments, the lens array does not move at all, but the PV array glass moves laterally to keep direct sunlight focused on the solar cell strips.

[0012] In certain example embodiments of this invention, a method of making a lens array for use in a solar photovoltaic module is provided. Glass is made using a float process or other process. The glass is patterned using a plurality of rollers disposed (e.g., potentially along the float glass) line so as to form a plurality of first lenses oriented along a common axis. The rollers each have profiles such that each said first lens is patterned to have at least one convex major surface when viewed in side cross section.

[0013] In certain example embodiments of this invention, a method of making a solar photovoltaic module is provided. A lens array comprising a plurality of lenses oriented along a common axis is provided, with the lenses being patterned using rollers (e.g., potentially along the float glass), and with

the lenses each having at least one convex major surface when viewed in side cross section. A plurality of elongate solar cells is provided, with each said solar cell comprising c-Si. The lens array is oriented relative to the solar cells such that each said lens is arranged to concentrate light incident thereon in substantially one dimension on the elongate solar cells. In certain example instances, a solar photovoltaic module is made in this way, and the photovoltaic module may be operated by connecting it to a single-axis tracking system at a fixed tilt, with the single-axis tracking system being movable so as to match the East-West movement of the sun. However, in certain example embodiments, the PV array substrate and lens array may be spatially separated from each other and the PV array moves laterally to maintain focus of the sunlight on the PV strip cells during the course of the day.

**[0014]** In certain example embodiments of this invention, a method of making a solar photovoltaic system is provided. At least one lens array comprising a plurality of lenses oriented along a common axis is provided, with the lenses being patterned using rollers, and with the lenses each having at least one convex major surface when viewed in side cross section. The at least one lens array is oriented relative to a plurality of elongate solar cells comprising c-Si such that each said lens is arranged to concentrate light incident thereon in substantially one dimension on the elongate solar cells.

**[0015]** In certain example embodiments of this invention, a photovoltaic system is provided. A plurality of elongate solar cells is provided, with each said solar cell comprising c-Si. A lens array comprising a plurality of lenses oriented along a common axis is provided, with each said lens being configured to concentrate incident light in substantially one dimension the elongate solar cells, and with each said lens having a concentration ratio of 3x-30x.

**[0016]** In certain example embodiments of this invention, a building product is provided. A plurality of elongate solar cells comprising c-Si is supported by a cover glass substrate. A lens array comprises a plurality of lenses oriented along a common axis, with each said lens being configured to

concentrate incident light in substantially one dimension on the elongate solar cells, and with the lens array being substantially parallel to and spaced apart from the cover glass substrate. Each said lens has a convex top and/or bottom surface when viewed in side cross section. The lens array is patterned from a single low-iron glass substrate. In certain example instances, a frame may be structured to maintain the lens array and the cover glass substrate in parallel spaced apart relation.

**[0017]** In certain cases, some example existing photovoltaic and building-integrated photovoltaic (BIPV) systems may focus primarily on electricity generations. In certain example embodiments of this invention, however, a BIPV system may be multi-functional in that it provides not only cost-effective electricity generation, but also other advantageous features such as daylight entry, variable solar control, thermal insulation, and/or an aesthetic building “skin.”

**[0018]** In certain example embodiments, the BIPV system may include a photovoltaic skylight. In some cases, the photovoltaic skylight may comprise an insulated glass unit (IGU).

**[0019]** In certain example embodiments, a BIPV system (e.g., photovoltaic skylight) may be provided on the roof of a building and/or other suitable structure. In certain example instances, the photovoltaic skylight may be installed on a roof at latitude tilts and may transmit diffuse daylight into the interior of the building, while converting direct sunlight into electricity at a relatively high efficiency.

**[0020]** The features, aspects, advantages, and example embodiments described herein may be combined to realize yet further embodiments.

#### BRIEF DESCRIPTION OF THE DRAWINGS

**[0021]** These and other features and advantages may be better and more completely understood by reference to the following detailed description of

exemplary illustrative embodiments in conjunction with the drawings, of which:

**[0022]** FIGURE 1 is an illustrative linear focusing concentrating photovoltaic system including a cylindrical lens array made from patterned glass according to an example embodiment;

**[0023]** FIGURE 2 is a schematic view of illustrative top and bottom roller profiles that may be used in a patterning line to obtain the lens array of certain example embodiments;

**[0024]** FIGURE 3 shows example dimensions of lenses in a lens array in accordance with an example embodiment;

**[0025]** FIGURE 4 is a graph showing the approximate cost per watt vs. concentration ratio (CR) of various different concentrating photovoltaic systems;

**[0026]** FIGURE 5 is a schematic view of an illustrative one-axis tracking system incorporating concentrating lens arrays in accordance with an example embodiment;

**[0027]** FIGURE 6 is a schematic view of two plano-convex arrays being laminated together in accordance with an example embodiment;

**[0028]** FIGURE 7 is a schematic view of a Fresnel-type lens array in accordance with an example embodiment;

**[0029]** FIGURE 8 is a hybrid thermal solar panel system that incorporates a lens array and strip solar cells in accordance with an example embodiment;

**[0030]** FIGURE 9 is an illustrative system that incorporates a patterned mirror array and strip solar cells in accordance with an example embodiment;

**[0031]** FIGURE 10 is a flowchart showing an example method of making a photovoltaic system in accordance with an example embodiment;

**[0032]** FIGURE 11 illustrates a perspective view of a photovoltaic skylight comprising strip solar cells capable of lateral movement based on the position of the sun, according to certain example embodiments;

[0033] FIGURE 12 is an example cross-sectional view of a dual glazing insulated glass photovoltaic skylight system in accordance with certain example embodiments;

[0034] FIGURE 13 illustrates an example embodiment of a triple glazing insulated glass photovoltaic skylight system in accordance with certain example embodiments;

[0035] FIGURES 14(a)-(d) illustrate how measurements can be taken from reference cylindrical lens(es);

[0036] FIGURES 15(a)-(c) illustrates an AR coating disposed on a lenticular array according to certain example embodiments;

[0037] FIGURE 16 illustrates certain example photovoltaic skylights installed at a latitude tilt, facing the equator; and

[0038] FIGURES 17(a)-(e) show, schematically, a view of an example multifunctional BIPV concentrating solar photovoltaic skylight in accordance with certain example embodiments.

#### DETAILED DESCRIPTION OF EXAMPLE EMBODIMENTS OF THE INVENTION

[0039] Photovoltaic devices such as solar cells convert solar radiation into usable electrical energy. The energy conversion occurs typically as the result of the photovoltaic effect. Solar radiation (e.g., sunlight) impinging on a photovoltaic device and absorbed by an active region of semiconductor material generates electron-hole pairs in the active region.

[0040] Certain example embodiments of this invention relate to patterned glass that can be used as a cylindrical lens array in a concentrated photovoltaic application, and/or methods of making the same. In certain example embodiments, the lens arrays may be used in combination with strip solar cells and lateral displacement tracking systems. That is, in certain example embodiments, lenses in the lens array may be arranged so as to concentrate incident light onto respective strip solar cells, and the solar cell

substrate is controlled a lateral displacement tracking system that is programmed to follow the East-West movement of the sun. A low-iron glass may be used in connection with certain example embodiments. Such techniques may advantageously help to reduce cost per watt related, in part, to the potentially reduced amount of semiconductor material to be used for such example embodiments.

**[0041]** As indicated above, certain example embodiments relate to patterned glass cylindrical lens arrays, and/or methods of making the same. In this regard, Fig. 1 is an illustrative linear focusing concentrating photovoltaic system including a substantially cylindrical lens array made from patterned glass according to an example embodiment. A large flat low iron glass plate is modified into a lens array 1 by periodically modifying its thickness, e.g., at regular intervals. The lenses 3a-3d in the lens array 1 focus the sunlight from the sun in substantially one dimension, with a concentration ratio of, for example, 3x to 30x. The solar radiation may be focused on, for example, c-Si solar cells, with an efficiency of as high as 20%. Such c-Si solar cells are commercially available at reasonable costs. Fig. 1 shows the c-Si solar cells being formed as strips 5a-5d. Further details regarding these strip solar cells 5a-5d are provided below. In any event, the c-Si solar cells may be provided on a transparent substrate in different embodiments of this invention. The lenses 3a-3d in the lens array 1 are provided substantially in-line along a common axis. The lenses 3a-3d may be formed from a single piece of glass in certain example embodiments. In such cases, the lenses 3a-3d may effectively be connected to one another by virtue of being formed from a common glass substrate. Alternatively or in addition, multiple lenses and/or lens arrays may be provided adjacent to one another in different example embodiments of this invention.

**[0042]** A patterning line in a glass factory may be used to create the large area cylindrical lens array of certain example embodiments. This can be done by using one or more sets of top and bottom rollers with the example

profile shown in Fig. 2. That is, Fig. 2 is a schematic view of illustrative top and bottom roller profiles that may be used in a patterning line to obtain the lens array of certain example embodiments. When viewed in cross-section, the individual top and bottom rollers 7a-7d and 9a-9d in the top and bottom roller arrays 7 and 9 are concave at the top and bottom. Thus, the rollers of Fig. 2 will lead to a convex-convex lens array. Of course, it will be appreciated that a plano-convex lens array may be obtained, as well, when either the top of bottom set of rollers is flat.

**[0043]** Fig. 3 shows example dimensions of lenses in a lens array in accordance with an example embodiment. Each lens in the Fig. 3 example has a pitch or width that ranges from approximately 5-100 mm, a minimum thickness or height from about 2-4 mm, and a maximum thickness or height of about 4-8 mm. Depending on the pitch, the focal length will be about 10-200 mm, e.g., from or proximate to the center of the individual lenses. Of course, it will be appreciated that the dimensions specified in Fig. 3 are provided by way of example. Indeed, different embodiments of this invention may include differently sized, shaped, and/or focal length lenses. For instance, the minimum thickness or height of certain example embodiments may be about 2 mm and the maximum thickness or height of certain example embodiments may be about 8 mm. In certain example embodiments, a 1 m<sup>2</sup> module may comprise about 10-200 lenses. The Fig. 3 example has a width of 25 mm, a minimum thickness of 3 mm, and a maximum thickness of 4 mm. These dimensions imply a height difference of 1 mm and 40 lenses per 1 m<sup>2</sup> module. In example instances, the focal length will be 150 mm, and the lens-solar cell distance may be placed at 135 mm to achieve a concentration ratio of about 10. Placing the solar cell closer to the focal point may be advantageous in certain example instances so that light is concentrated on a larger area of the solar cell.

**[0044]** Any suitable transparent substrate may be used in connection with certain example embodiments of this invention. For instance, certain example embodiments may incorporate a low-iron glass substrate, e.g., to help

ensure that as much red and near-IR light as possible is transferred to the semiconductor absorber layer. Example low-iron glass substrates are disclosed, for example, in co-pending and commonly assigned Application Serial Nos. 11/049,292; 11/122,218; 11/373,490; 12/073,562; 12/292,346; 12/385,318; and 12/453,275, the entire contents of each of which are hereby incorporated herein by reference.

**[0045]** For instance, certain example embodiments may incorporate a high transmission low iron glass. Further details of example low iron glass are provided below.

**[0046]** In addition, the low iron glass may be thermally tempered. Such tempering may occur in certain example embodiments at the end of the production line, e.g., after the glass has been patterned in certain example instances.

**[0047]** Current CPV systems typically implement two-axis tracking because they use two-dimensional focusing. In this regard, current CPV systems usually are mounted on poles with individual tracking for each unit system. This arrangement increases the cost of the system. By contrast, certain example embodiments that implement cylindrical lens arrays reduce (and sometimes completely eliminate) the need for dual-axis tracking. This is because the cylindrical lens arrays of certain example embodiments are configured to linearly focus sunlight on or along a strip as opposed to a smaller point or spot location. Indeed, when the cylindrical lenses of certain example embodiments are oriented substantially vertically, simple East-West one-axis tracking may be implemented easily and efficiently.

**[0048]** In Table 1 the annual energy outputs from a 20% efficient system at an example location (Phoenix, Arizona) are compared for fixed latitude tilt, one-axis tracking, and two-axis tracking systems. More particularly, the solar cells are high efficiency, back contact solar cell strips commercially available from Sunpower. The improvement in energy output going from a fixed orientation system to a one-axis tracking system is 30.7%. This is a very

significant gain. However, the improvement of moving from a one-axis tracking system to a dual-axis tracking system is only an additional 5.8%. This additional 5.8% energy gain typically is offset by the expense of the dual-axis tracking system itself. Current dual-axis tracking systems therefore are not seen as economical. In any event, certain example embodiments that implement a linearly focused system are able to realize at least the efficiency gains associated with moving from a single-axis tracking system to dual-axis tracking system without actually having to incur the expenses associated with the dual-axis tracking system because such embodiments may be implemented with only one-axis tracking systems.

Table 1: Annual energy output per m<sup>2</sup> incident sunlight for fixed orientation, one-axis tracking, and two-axis tracking systems in Phoenix (based on NREL PVWatts Calculator)

			Annual energy generation (kWh/m <sup>2</sup> /yr)		
	PV technology	Conversion Efficiency	Fixed orientation (On roof) Lat. tilt	One-axis E-W tracking	Two-axis tracking
Phoenix	High eff. c-Si	20%	386.53	505.52	534.80
33° 43° N			~100%	~131%	~138%

**[0049]** It will be appreciated that single-axis tracking systems advantageously can be implemented at low cost, because many modules can be oriented with a single actuator by connecting all modules to each other through parallel beams. The lens array is oriented substantially vertically and is therefore largely self-cleaning, as rain will flow down in the grooves of the patterned glass and reduce the amount of dust accumulation. Additional periodic cleaning optionally may be implemented, of course. Single-axis tracking systems also may be low to the ground, as the mechanisms for moving it are simplified compared to the mechanisms used for two-axis tracking systems.

**[0050]** The solar cells in the Fig. 1 example system may be manufactured economically, e.g., by cleaving strips from c-Si solar cells. For instance, a larger (e.g., 4 inch to 12 inch) wafer may be formed and subsequently cleaved to produce a plurality of strips. For concentration ratios of 3x to 30x, only about 33% to 3.3% silicon is needed, as compared to conventional c-Si modules without concentration which may require higher amounts of silicon.

**[0051]** As alluded to above and as suggested in the use of the term “strip” itself, the strip solar cells of certain example embodiments may have a substantially elongated shape. For instance, certain example strip solar cells may be 2 mm x 150 mm, although other dimensions also are possible. In any event, the strip solar cells may be cleaved along the direction of its crystal orientation. The strip cells optionally may be mounted on a second glass substrate or another type of substrate in certain example embodiments. In so doing, the second substrate may be made to function as a heat sink, thereby helping to keep the operating temperature of the solar cells low and their efficiency high. Active cooling may be used in place of, or in addition to, such heat sink techniques in certain example embodiments.

**[0052]** In connection with example embodiments that implement strip solar cells, low-cost assembly techniques known and commonly used in, for example, the flat panel display (FPD) industry, may be used. For example, such techniques may readily be used in connection with strip solar cells having a width of 2-20 mm, and such techniques may include, for example, chip on glass (COG) manufacturing. These COG manufacturing techniques may, in turn, incorporate interconnecting wires such as, for example, patterned metals provided on the glass, copper tape, and/or the like. Certain example embodiments may incorporate solar cells with low shading or non-shading interconnects. Non-shading interconnects sometimes are used, for example, in back contact solar cells (e.g., available from Sunpower).

**[0053]** Fig. 4 is a graph showing the approximate cost per watt vs. concentration ratio (CR) of various different concentrating photovoltaic systems. The Fig. 4 graph is based on the following assumptions. For CRs greater than 100, expensive multi-junction GaAs cells need to be used with active cooling. For CRs greater than 100, two-dimensional concentration is needed with dual-axis tracking. For CR less than 100, one-dimensional (e.g., cylindrical) concentration is used along with single-axis tracking. The cost per watt for the solar cell includes costs associated with packaging and interconnects, and the cost per watt for the concentrating optics includes costs associated with alignment. The Fig. 4 graph allows efficiency to exceed 20%. As will be appreciated from the Fig. 4 graph, a concentration ratio of about 10-30x is particularly desirable from a cost per watt perspective.

**[0054]** It will be appreciated that there are a number of advantages associated with certain example embodiments of this invention. For example, the 3x to 30x concentration optics may be produced easily and inexpensively using patterned glass. This may, in turn, also allow for a 3x to 30x smaller area of c-Si solar cells. Cylindrical lens arrays may be substantially self-cleaning when installed vertically at a latitude tilt in certain example implementations, as the amount of dust and/or other debris that will accumulate will be reduced, since rain will clean the grooves of the vertically positioned patterned glass lens array. Certain example embodiments also enable low cost and known, reliable assembly techniques from the FPD industry to be used in connection with strip solar cells (e.g., when they are provided with a width of about 2-20 mm). Also, as noted above, the use of low-cost single-axis tracking or lateral displacement systems may in certain example embodiments advantageously improve power output as compared to fixed orientation systems. Furthermore, many modules may be easily connected to the same single-axis tracking system. The use of such example techniques in high direct-insolation areas such as the Southwest USA may lead to higher annual energy output.

[0055] Fig. 5 is a schematic view of an illustrative one-axis tracking system incorporating concentrating lens arrays in accordance with an example embodiment. The illustrative system in Fig. 5 includes a plurality of concentrating lens array modules 11. Each such module 11 may be the same as or similar to the arrangement shown in Fig. 1, for example. That is, each module may include a lens array that concentrates light on strip solar cells, e.g., of c-Si. The individual modules 11 may be connected to a common power source, e.g., using interconnects 12. The modules 11 also may be controlled such that they move in a direction that matches the East-West movement of the sun.

[0056] In certain example embodiments, antireflective (AR) coatings may be provided to one or both sides of the lens array to increase transmission. In certain example embodiments, a broadband AR may be provided using any suitable technique. In certain example instances, a low index silicon oxide (e.g., SiO<sub>2</sub> or other suitable stoichiometry) coating having an index of refraction of about 1.3 may be provided on one or both sides of a lens array through a wet application process (e.g., a dip, spray, roll, or other coating process), for a sol, for example. Such a technique may lead to for example, a 3-6% increase in lens array transmission and/or module power, depending on the coating used and the number of surfaces coated.

[0057] In certain example embodiments, the lens array may be heat strengthened and/or thermally tempered. Of course, thermal tempering may be difficult to accomplish in connection with patterned glass having varying thicknesses. Chemical tempering and/or strengthening techniques therefore may be used in connection with certain example embodiments.

[0058] As another alternative or addition, lens arrays may be laminated together, e.g., as shown in Fig. 6, which is a schematic view of two plano-convex arrays being laminated together in accordance with an example embodiment. In Fig. 6, first and second plano-convex arrays 13a and 13b are provided. The first and second plano-convex arrays 13a and 13b are laminated

together using any suitable laminate material 15. For instance, PVB, EVA, or the like may be used to laminate together the first and second plano-convex arrays 13a and 13b. The individual arrays 13 may be individually strengthened or tempered (thermally, chemically, or otherwise) in certain example instances, as the variations in thickness may be less severe and thus easier to process in comparison to convex-convex type lens arrays. In certain example instances, the laminate 15 itself may help to strengthen the overall array.

**[0059]** Fig. 7 is a schematic view of a Fresnel-type lens array in accordance with an example embodiment. As is known, Fresnel lenses generally have large apertures and short focal lengths, without the weight and volume of material that would be required in conventional lens design. In addition, Fresnel lenses tend to be thinner, thereby allowing more light to pass through them. The comparatively lower thickness variation may enable Fresnel lenses to be tempered. Although the example lens in Fig. 7 is patterned on both major axes, it will be appreciated that one side of the lens may be planar or substantially planar and the other side may be patterned. In certain example embodiments, such lenses having one planar side and one Fresnel patterned side may be laminated together, e.g., using the techniques and/or materials described above.

**[0060]** Fig. 8 is a hybrid thermal solar panel system that incorporates a lens array and strip solar cells in accordance with an example embodiment. The Fig. 8 example system is similar to the Fig. 1 example system in that it includes a lens array having a plurality of lenses 3a-3d, and a plurality of strip solar cells 5a-5b. Light from the sun is focused on the strip solar cells 5a-5b to produce electricity. The Fig. 5 example hybrid system also includes tubing 17a and 17b through which water or another suitable fluid may flow. Cool water is fed into the tubing 17a and 17b proximate to the strip solar cells 5a-5b, continues in a path (which in the Fig. 8 example embodiment is substantially U-shaped), and exits remote from the strip solar cell. Providing cool water proximate to the strip solar cells is advantageous in that it improves the

efficiency of the c-Si. In this regard, it is known that the efficiency of c-Si solar cells drops significantly at higher temperatures (e.g., at 60 degrees C) and improves at lower temperatures (e.g., at 25 degrees C). The provision of cooler water proximate to the strip solar cells therefore may improve the operational efficiency of the system.

**[0061]** Although the presence of cooling water may increase efficiency of an individual strip solar cell, the overall solar cell efficiency may be decreased by providing fewer total solar cells, e.g., because a solar cell may not be provided along the return path for the hot output water. Nevertheless, overall efficiency may be improved by virtue of the cooling water's effect on the strip solar cells that are present and the further heating of the water via the lens array throughout the entire path, including the return path (where there is no solar cell). The heated water, of course, may be used as it otherwise would be used in connection with a thermal solar power application. As explained in greater detail below, the lens array and/or the tubing may move relative to one another, e.g., so as to match the East-West movement of the sun. This may be advantageous, for example, in building-integrated photovoltaic (BIPV) applications.

**[0062]** Focusing additionally or alternatively may be performed using a patterned mirror array. Fig. 9 is an illustrative system that incorporates a patterned mirror array and strip solar cells in accordance with an example embodiment. In Fig. 9, strip solar cells 3a-3d are provided, directly or indirectly, on a cover glass substrate 19. For instance, the cover glass substrate 19 may be closer to the sun, and the strip solar cells 3a-3d in certain example instances may be provided on a major surface of the cover glass substrate 19 opposite the sun. In certain example embodiments, the cover glass substrate may be made from low iron float glass. In certain example embodiments, an AR coating may be applied thereto. Light passing through the cover glass substrate 19 may be reflected and concentrated back towards the strip solar cells 3a-3d using a mirror array 21. The mirror array 21 may be a piece (or

multiple pieces) of patterned glass that has been coated with a reflective coating. Light impinging on the troughs or concave areas 21a-21d in the mirror array 21 therefore may be reflected back towards the strip solar cells 3a-3d. As above, relative movement of one or both of the cover glass substrate 19 and the mirror array 21 may be caused so as to improve efficiency (e.g., by tracking the East-West movement of the sun).

**[0063]** Although certain examples have been described in connection with a fixed or stationary solar cell module and a moving lens array, certain other example embodiments may involve a fixed or stationary lens array and a moving solar cell module. In the latter case, the lens array may be stationary at a fixed orientation, and the solar cell array may be configured to move during the day to maintain the focus of the light from the sun on the strip solar cells, e.g., to match the East-West movement of the sun. In this regard, the strip solar cells may be provided on a substrate as described above, and the substrate may be made to move. Such example embodiments may be used, for instance, in connection with building-integrated photovoltaic applications, similar to self-regulating windows. Self-regulating windows are known to dynamically adjust the amount of light passing therethrough, e.g., using diffusers, blinds, or the like. In certain example embodiments, the movement of the sun may be tracked (directly or indirectly, e.g., based on time of day and/or day of year) so that the substrate may be moved appropriately to increase or maximize the amount of sunlight impinging on the solar cells. It will be appreciated that diffuse light may be transmitted in such instances, and direct sunlight may be converted into electricity by the photovoltaic cells.

**[0064]** The following table compares cost per watt for various types of photovoltaic technologies.

Table 2: Estimated Cost per Watt for Photovoltaic Technologies Using Phoenix, Arizona as an Exemplary Location

	Efficiency	Tracking	Annual Power Output per m <sup>2</sup> Module Area	Cost per Watt
Polycrystalline silicon	15%	None	290 kWh	\$1.40
Thin film CdTe (e.g., First Solar)	11%	None	212kWh	\$0.98
Example (e.g., Lens Array)	20%	One-Axis East-West	505 kWh	\$0.85

**[0065]** As can be seen, the example in Table 2 produces 2.4x higher output per square meter as compared to CdTe type photovoltaic systems for direct sunlight. The example in Table 2 also provides a potentially lower cost/watt compared to CdTe type photovoltaic systems.

**[0066]** Fig. 10 is a flowchart showing an example method of making a photovoltaic system in accordance with an example embodiment. Soda lime glass (e.g., low iron glass) is patterned, optionally using a plurality of top and bottom rollers, to form a lens array comprising a plurality of lenses oriented along a common axis in step S101. In step S103, a c-Si solar cell is formed on a wafer and, the wafer is cleaved along the c-Si crystal orientation into a plurality of elongate solar cells in step S105. The elongate solar cell strips are provided in substantially parallel spaced apart relation to one another in step S107. In step S109, the lens array is oriented relative to the solar cells such that each said lens is arranged to concentrate light incident thereon in substantially one dimension on one respective elongate solar cell. Optionally, in a step not shown, the lens array and the plurality of elongate solar cells may be mounted to a single-axis tracking or lateral displacement system, with such a system being programmed to move so as to substantially match the East-West movement of the sun, e.g., to maximize the amount of light incident on the lens array and concentrated on the strip solar cells.

**[0067]** Certain example embodiments may be used as windows, skylights, roof-mounted PV modules, or the like in connection with BIPV applications. For example, in rooftop applications, full size solar cells may be

replaced with strip cells. The lens array may be provided in substantially parallel spaced apart relation to the strip solar cells. Known tabbing, framing, and junction box technology may be leveraged to help provide BIPV applications.

**[0068]** It will be appreciated from the description above that certain example applications may be structured somewhat similarly to insulating glass (IG) units. The first or outer pane may be the cylindrical lens array, whereas the second or inner pane may have the strip solar cells formed thereon. Rather than spacers, window frame components may help maintain the panes in substantially parallel, spaced apart relation to one another, e.g., at the appropriate focal length. In certain example embodiments, when the lens array has a flat surface, this side may face outwardly, e.g., towards the sun. Of course, providing patterned glass may be viewed as a desirable aesthetic feature in certain example instances, and a patterned surface may face outwardly in such cases.

**[0069]** For instance, solar panels may be produced by slicing silicon solar cell wafers into narrow strips. In certain instances, solar panel systems such as the foregoing may be advantageous in certain respects, for example, in that they may reduce the area of expensive silicon solar cells required by a factor of more than two.

**[0070]** As social and political pressures increase to improve efficiency and implement “green” technology, it may be desirable to implement methods and/or products that help improve the efficiency of, for example, the operation of buildings and the like (e.g., with respect to electricity usage, etc.). It will be appreciated that in certain scenarios, the efficiency of a building may be improved through different avenues. For example, photoelectric controls, solar shading, and/or glass performance may be improved and/or implemented, in order to increase operating efficiency in certain instances. Certain example photoelectric controls relate to the inclusion of controls that can improve “daylighting,” e.g., by improving interior lighting through the use of natural,

outside light. Solar shading, in certain instances, may include the addition of horizontal and/or vertical devices. Finally, another example technique for controlling efficiency is through glass performance – e.g., improving the solar and/or thermal properties of glass substrates and units used as windows in buildings.

[0071] Table 3 illustrates certain existing percentages by which the efficiency of certain structures may be improved through photoelectric controls, solar shading, and glass performance, from a report entitled “Driving Transformation to Energy Efficient Buildings: Policies and Actions.”

Table 3

High Impact Measures	Office	Retail	Hotel	Hospital	Apt	School
Photoelectric controls	18%	11%	NA	17%	NA	10%
Solar shading	17%	11%	18%	18%	8%	2%
Glass performance	15%	6%	16%	14%	11%	5%

[0072] Accordingly, it will be appreciated that there is an opportunity to further improve the efficiency of certain building operations, in some instances. For example, assemblies and/or methods for making these assemblies that include some degree of photoelectric control, solar shading, and improved glass performance would be desirable. The implementation of BIPV systems into existing structures and/or new construction may advantageously help further improve operating efficiency of these structures.

[0073] Unfortunately, certain existing BIPV systems have not yet been substantially commercialized (e.g., in high volume) due to several drawbacks. For example, certain existing BIPV systems are installed vertically, and do not take full advantage of the direction and/or angle of the sun, particularly in southern locations where the sun may be overhead for much of the time. Furthermore, certain existing BIPV systems may be opaque, and therefore may

not allow daylight to enter the building. In some cases, when BIPV systems are partially transparent (e.g., do allow some daylight to enter the building), it is usually at the expense of PV efficiency and electricity output. Additionally, certain existing BIPV systems may not substantially provide thermal insulation, and/or may fail to provide solar heat gain control. Thus, it will be appreciated by one skilled in the art that there is a need for an improved BIPV system that overcomes the foregoing shortcomings.

**[0074]** Certain example embodiments described herein relate to improved BIPV systems (e.g., building integrated photovoltaics), and methods of making the same. Certain example embodiments of the assemblies described herein may include photovoltaic skylights, windows, windshields, sunroofs for automobiles, and/or other photovoltaic applications. The assemblies described herein may include dual or triple glazing units in certain example embodiments. Assemblies including example improved BIPV systems may be installed in existing roof and/or façade areas in certain example instances. Of course, certain assemblies described herein may also be installed during new construction. In certain example embodiments, assemblies including improved BIPV systems may replace existing building materials with a potentially more cost-effective system.

**[0075]** In certain example embodiments, assemblies as described herein may advantageously (1) be installed at a latitude tilt, such that they face the equator, in order to increase the amount of direct sunlight incident upon the lenticular array; (2) permit diffuse daylight entry into a structure, while utilizing most or substantially all of the direct sunlight for the solar cells; (3) provide self-regulating or dynamic solar heat control, including a lower solar heat gain coefficient when necessary, and/or (4) provide improved thermal insulation.

**[0076]** Fig. 11 illustrates a perspective view of an assembly according to certain example embodiments. The assembly of Fig. 11 may be a photovoltaic skylight, in certain example embodiments. The assembly of Fig. 11 may

comprise a lenticular array (e.g., lens array, cylindrical lens array, etc.) and a substrate supporting solar cells, arranged together in a frame or the like to form a double glazing unit. The assembly may be disposed on a building, roof, façade, etc., such that sunlight will be incident upon and concentrated by the lens array. The light then may be focused upon the solar cells. As can be seen from Fig. 11, the cylindrical lens array may include plural lenses 3a-3d that focus the light on the strip solar cells 5a-5d, respectively. As described in greater detail below, the lens array and/or the strip solar cells may move relative to one another, e.g., from position 1 to position 2 (and intermediate points), to account for the sun's movement in the sky (e.g., from east in the morning to west in the afternoon).

**[0077]** Fig. 12 is an example cross-sectional view of a dual glazing insulated glass photovoltaic skylight system 75 in accordance with certain example embodiments. In Fig. 12, first substrate 100 comprises a lenticular array 3, and solar cells 5 are disposed on second glass substrate 200. Substrates 100 and 200 are separated by air gap 50. Together, substrates 100 and 200 form a dual glazing unit. Fig. 12 further illustrates slide mechanism 40. Slide mechanism 40 may be included in certain example embodiments to assist with lateral movement of the solar cells and/or substrate 200, e.g., relative to one another. Furthermore, an optional low-E coating 4 may be disposed on an interior surface of assembly 75 in Fig. 12. Low-E coatings may be included in assembly 75 in certain example embodiments; e.g. on an interior surface of a substrate in the assembly. Although not expressly shown, a low-e coating may be disposed on one or more surfaces of any substrates in an assembly 75 according to any example embodiment. Furthermore, anti-reflection coatings may also be provided on one or more surfaces of any of the substrates.

**[0078]** If certain example embodiments, the assembly may include an additional (e.g., third, or even more) glass substrate, and may be a triple glazing unit. Fig. 13 illustrates an example embodiment of a triple glazing BIPV system in accordance with certain example embodiments. In Fig. 13, lenticular

array 100, and substrate 200 supporting strip solar cells 5, are arranged in an insulating unit in connection with a frame 40, with an air gap 50 between the first and second substrates. Substrate 200 is capable of lateral movement as shown by pockets 70. In addition, in example triple glazing embodiments, a third substrate 300 is provided on the opposite side of substrate 200 as substrate 100, creating a second air gap 60 between substrates 200 and 300. In certain example embodiments, substrate 300 may be any suitable glass substrate. Although not shown in Fig. 13, a low-e coating may be disposed on one or more surfaces of any substrates in an assembly 75 according to any example embodiment. Interior surfaces 2, 4, and 5 may be desirable locations for such a coating, as they may protect the functional layer(s) of the low-E coatings or the like. Furthermore, anti-reflection coatings may also be provided on one or more surfaces of any of the substrates.

**[0079]** Because of the (at least) double glazing nature of certain example embodiments of the assembly, some degree of thermal insulation may result, in certain example instances. In addition, the air gap provided between the first and second and/or second and third substrates may be substantially evacuated and/or filled with an inert gas (e.g., Ar, N, Xe, and/or the like) in order in forming an insulated glass unit. This may further improve thermal insulation in certain examples. It will be appreciated that in certain example embodiments, a triple glazing assembly may advantageously provide an even greater degree of thermal insulation than similar dual glazing systems when implemented as a window and/or skylight. However, in other example cases the air gap may simply include air.

**[0080]** In certain examples, the assemblies of Figs. 11, 12, and/or 13 may be integrated into a roof or cover-like structure of a building, car parking structure (e.g. to recharge electric cars or sunroofs of electric cars to recharge their batteries), etc. In certain instances, the assemblies of Figs. 11, 12, and/or 13 may be installed at a latitude tilt, such that they face the equator, and increase the amount of direct sunlight incident upon the lens array. In case the

module is mounted as the sunroof of a moving or parked vehicle, a photosensor may control the lateral displacement of the PV array with respect to the lens array, since the direction of solar incidence would depend on the direction in which the vehicle is moving or parked.

**[0081]** During the course of the day, the sun moves from the east to the west. In certain example embodiments, the glass substrate supporting the strip solar cells illustrated in Figs. 11, 12, and/or 13 may move from left to right in the figure; relative to the lenticular array. In other words, in certain example embodiments, the overall assembly may remain in a fixed or substantially fixed position with respect to the surface upon which it has been installed, while the substrate supporting the strip solar cells moves laterally with respect to the lenticular array, and within the fixed or substantially fixed assembly. In certain instances, this may maintain the focus of the light substantially directly on the solar cells.

**[0082]** It will be appreciated that this type of movement (e.g., part of the unit remaining substantially fixed while another aspect of the unit moves with respect to the fixed aspect) may be different from other one axis tracking systems. For example, in other cases, the position of the solar cells may be fixed with respect to the lens array, and the sun may be tracked by using one axis tracking, or even two axis tracking, in some situations. However, as explained above, the implementation of system tracking by moving the solar cells substantially laterally, relative to the lenticular array may replace one or two axis tracking,

**[0083]** In certain example embodiments, tracking by moving the solar cells laterally relative to the lens array may be more advantageous than situations in which the position of the solar cells is fixed with respect to the lens array. For example, this may enable the assembly to be more easily integrated into existing structures and/or new construction. In certain cases, this may enable the overall assembly to remain substantially stationary within the building, roof, façade, or the like (e.g., the only movement occurs within a

substantially fixed frame and/or the like); while still permitting the sunlight to remain focused on the solar cell strips throughout the course of the day, as described above.

**[0084]** As a result of this relative shift of the solar cells with respect to the lenticular array, the solar cells may continue to generate electricity while partially or substantially blocking direct solar radiation from entering the building, thereby reducing glare. This may provide self-regulating solar heat control, in certain example embodiments. For example, when the assembly is exposed to an uncovered sun, in full daylight, the solar cells may absorb substantially all of the direct light, and consequently block direct solar radiation from entering the building. Thus, the solar heat gain coefficient of certain example assemblies may advantageously be lowered during situations where this would be desirable.

**[0085]** On the other hand, diffuse light (e.g., light not directly from the sun, but nonetheless incident upon the glass surface), may not be focused on the solar cell strips, and may pass between the solar cells, in certain example embodiments. The diffuse light entering the building may advantageously provide lighting therein. In certain example embodiments, the diffuse lighting may be provided in the building and/or structure without significantly impacting (e.g., decreasing) the photovoltaic efficiency and/or electricity output. Furthermore, the increase in diffuse light entry may also advantageously reduce the need for artificial lighting, in certain example embodiments.

**[0086]** Turning more particularly to the structure(s) and advantages relating to the example improved BIPV systems described above, in certain instances these assemblies may include a lens array (e.g., cylindrical lens array (CLA), lenticular array, etc.) and a substrate supporting solar cells, the substrate being capable of lateral movement, in certain example embodiments.

**[0087]** Direct solar radiation focused by a lenticular array on the strip solar cells is shown in Fig. 11. For example, a concentration ratio of the

lenticular array may be from about 1.5x to 30x, more preferably from about 2x to 20x, and most preferably from about 3x to 10x, and all subranges therebetween.

**[0088]** An example lens array is shown in Fig. 3. Fig. 3 illustrates a cylindrical lens array (CLA). Certain example embodiments of CLAs have been described herein. Lens arrays are used in the optics industry and the display industry, for example. In certain instances, CLAs may be used in three dimensional (3D) displays. As indicated previously, CLAs may be plano-convex lenses in certain examples. However, CLAs may also be convex-convex lenses.

**[0089]** The CLA illustrated in Fig. 3 is an example plano-convex lens array. For example, in the case of a plano-convex lens array, the focal length may be similar for collimated light entering from the planar side and the convex side. The example lens array dimensions are described above with respect to Fig. 3. These dimensions are for purposes of example. In certain cases, the lens design may depend, at least in part, on the feasible glass thickness variation (e.g., a maximum amount by which the thickness of the glass can vary throughout the substrate), and the width of the solar cells (e.g., the aspect ratio, etc., of the strip solar cells).

**[0090]** As indicated above, in a triple insulating glass unit embodiment, a low-E coating may be provided on surface 4 and/or surface 5. One or more surfaces (e.g., of the middle substrate) may be etched to help promote diffusion of light through the unit. AR coatings also may be used. Example low-E and AR coatings, and their configurations, are set forth in U.S. Application Serial No. 13/324,267, filed on December 13, 2011, the entire contents of which are hereby incorporated herein by reference. Additional example low-E coatings are set forth below, and additional example AR coatings include those disclosed in U.S. Patent No. 7,767,253, as well as U.S. Publication Nos. 2012/0057236, 2011/0157703, 2009/0133748, 2009/0101209, 2009/0032098, 2009/0025777, and U.S. Application Serial Nos. 13/360,898 (filed January 30,

2012) and 13/361,754 (filed January 30, 2012). The entire contents of each of these documents is hereby incorporated herein by reference. Using Phoenix Arizona as an example, such a unit would be expected to produce 175-750 kWh/m<sup>2</sup>/year, more preferably 225-500 kWh/m<sup>2</sup>/year, with an example energy production being 258 kWh/m<sup>2</sup>/year. In certain example embodiments, under direct sun light, the solar heat gain coefficient (SHGC) preferably is less than 0.40, more preferably less than 0.20, still more preferably less than 0.15, and sometimes 0.12 or lower. By contrast, in cloudy conditions, SHGC preferably is less than 0.80, more preferably less than 0.65, and sometimes about 0.5 or lower. Of course, higher or lower values may be provided in different climates and/or geographic regions. The U-value of the assembly when both low-E and AR coatings are provided may be less than 0.5, more preferably less than 0.35, and sometimes about 0.2. Visible transmission in such circumstances may be about 50%, although higher or lower values may be provided based on the desired application.

**[0091]** Figs. 14(a)-(d) illustrate how measurements can be taken from reference cylindrical lens(es). For example, Fig. 14(a) illustrates a reference cylindrical lens C. A point light source A is directed towards the white matte screen D through the lens C, and a digital camera B records the image produced on a white matte screen D. Fig. 14(b) shows a cross sectional view of a cylindrical lens from Edmund Optics, e.g., of the sort that may be used as lens A in Fig. 14(a). Fig. 14(c) is an example image taken by the camera. The narrow white band is illustrative of concentrated light. Fig. 14(d) is a graph plotting the (unitless) light intensity versus normalized position for the example cylindrical lens. The Fig. 14(d) graph helps demonstrate that in certain example embodiments, cylindrical lens arrays (e.g., of or including patterned glass) may have more than 90% focusing efficiency. In certain example embodiments, a patterned glass CLA may have a focusing efficiency of at least about 70%, more preferably at least about 80%, and most preferably about 90%, in certain example embodiments.

[0092] It will be appreciated that the lens arrays disclosed herein may include glass, plastics, and/or other suitable materials.

[0093] As described herein, the lenticular array may focus and/or concentrate the incident light into a small area, and this concentrated light may be transmitted through the array and be incident upon one or more solar cells. The solar cells may be lined up such that their location substantially corresponds to the size, shape, and/or position of the concentrated light transmitted through the lenticular array. In this regard, the smaller the area into which the light can be concentrated, the narrower the solar cell may be, in certain instances. Narrower strip solar cells may advantageously permit more diffuse light to pass through the lenticular array and substrate supporting the solar cells, into an interior of the building upon which the assembly is disposed, in certain example embodiments.

[0094] Lens arrays for concentrated photovoltaics (CPV) may be cost-effectively manufactured in several ways, including, for example, by patterning glass as described in co-owned and commonly assigned U.S. Publication Nos. 2011/0259394 and 2011/0263066, both incorporated herein by reference. In certain examples, the glass may be of or include low iron glass. In further example embodiments, lenticular arrays for CPV applications may be made by laminating a plastic, molded, lenticular array (for example, made from PMMA) to a glass substrate (e.g., a low iron glass substrate). In this case, the lens array is in an interior position, while the glass substrate protects it from the elements outside.

[0095] In certain example embodiments, an anti-reflection coating may be disposed on a surface of a lenticular array. Figs. 15(a)-(c) demonstrate how one or more AR coatings may be disposed on a lenticular array. More particularly, Figs. 15(a)-(c) show that the AR coating 80 may be single or double sided (e.g., as in Figs. 15(b)-(c) and Fig. 15(a), respectively), in certain example embodiments, and may be provided on either the first or second surface of the lenticular array (or both, of course). In certain example

embodiments, a two-sided AR coating may cause up to a 6% increase in lens array transmission and/or photovoltaic output. Similarly, a single-sided AR coating may permit an increase in transmission and/or output of up to about 3%. Suitable AR coatings are described in, for example, U.S. Publication Nos. 2011/0157703 and 2012/0057236, as well as U.S. Application Serial No. 12/929,481, filed on January 27, 2011. In certain example embodiments, the solar cells may be of or include any suitable material. However, in certain example embodiments, the solar cells may be silicon strip solar cells. Certain silicon strip solar cells have been commercialized by Solaria in 2x CPV panels. In those instances, the solar cell strips may be directly mounted on the back of the lenticular array.

**[0096]** In some cases, solar cell strips may be directed attached to the back of the cylindrical lens array, effectively requiring single axis tracking. See, for example, U.S. Patent No. 8,119,902, as well as U.S. Publication Nos. 2012/0067397, 2011/0315196, 2011/0186107, 2011/0168232, 2010/0294338, 2009/0056788, 2008/0289689, which show these and/or other associated designs.

**[0097]** Slim chip technology and packaging have been used in some instances for driver chips in the flat panel display industry. In certain example embodiments, elongated silicon strips with a relatively high aspect ratio may be utilized. For example, the aspect ratio (e.g., length to width) may be about 10:1, more preferably about 15:1, and most preferably about 20:1 (e.g., 10mm x 1mm, 20 mm x 2 mm, 15mm x 1mm, 20mm x 1mm, etc.), but in certain instances it may be even greater. For example, in certain example embodiments, driver ICs for LCDs (e.g., in the flat panel display industry) may have a length greater than 30 mm long and a width of less than 1.5 mm. These strips may be directly or indirectly mounted on glass with low cost Chip on Glass (COG) technology, in certain examples.

**[0098]** Solar cells with only back contacts (e.g., from Sunpower), may be preferred in certain examples, to avoid shading effects. Furthermore, in

certain example embodiments, solar cells having only back contacts may be mounted directly on a glass substrate with a low-cost COG technology. However, in other example embodiments, the solar cells may have front and/or back contacts.

**[0099]** Furthermore, certain example methods of wafer slicing that may be used on certain solar cells may advantageously lead to lower cost strip solar cells with lengths up to 6 or 8 inches (and in some cases even longer), in certain cases. These wafer slicing techniques may advantageously be used, in particular, on high efficiency back contact solar cells, in certain example embodiments. In certain example embodiments, wafer slicing techniques used on high efficiency back contact solar cells (e.g., manufactured by Sunpower), may lead to ultralow cost (e.g., on the order of cents) strip solar cells with a length up to, for example, 6 or 8 inch wafer dimensions (e.g., 150 to 210 mm).

**[00100]** Thus, it will be appreciated from the foregoing that elongated silicon strips with relatively high aspect ratios may be attached directly or indirectly to glass substrates at a relatively low cost.

**[00101]** Additionally, certain example assemblies described herein may advantageously differ from other commercialized solar strips. For instance, in certain example embodiments of the instant invention, the lenticular array and substrate supporting the solar cells may be disposed in a frame such that an insulating glass unit may be formed. In certain instances, an air gap may be provided between the first glass substrate (e.g., the lenticular array), and the second glass substrate with the solar cells. In certain instances, the substrates are spaced farther apart to form the air gap. As a result of the increased distance between the lenticular array and the solar cells, higher concentration ratios may be possible (e.g., from about 2x to 20x, preferably from about 3x to 10x and all sub-ranges therebetween). This increase in concentration of the light, and consequent reduction in size of the “beam” of light, may advantageously reduce the necessary width of the silicon solar cells, in certain cases. Such a reduction in area may also further reduce costs associated with

the solar cells (e.g., since a smaller area of solar cells may consequently reduce the amount of solar cell material needed).

**[00102]** As described above, the substrate supporting the solar cells may be configured for lateral movement within the assembly. In other words, certain example embodiments of assemblies described herein may advantageously include a lateral movement mechanism for only the lower substrate, e.g. the substrate supporting the solar cells. In that regard, the lens array and substrate supporting the solar cells may be supported together in a frame, and in certain instances the frame may be provided such that it permits lateral movement of the substrate supporting the solar cells.

**[00103]** Certain example embodiments may advantageously permit the solar cells (e.g. strip solar cells) to remain substantially in line with the “beam” of light focused by the lenticular array, as the sun’s position in the sky changes throughout the day, without the need for more conventional one or two axis tracking systems. This lateral movement capability may in certain example embodiments advantageously enable an assembly to be installed in and/integrated with a building, structure, and/or the like, in a fixed manner, such that the assembly, overall, remains substantially stationary (e.g., permitting better seals, less cumbersome frames, etc.). This lateral movement may be used instead of one or two axis tracking, in certain example embodiments.

**[00104]** For example, in order to maintain the focus of direct sunlight on the solar cell strips, in certain example embodiments, the second glass substrate (e.g., the substrate upon which the solar cells are disposed) may be made to move throughout the course of the day. This movement may be on the order of a cm to an inch, in certain implementations. Referring once again to Figs. 12 and 13, it is noted that the solar cell substrate (200) may be mounted on a low friction hinge mechanism or slide or rail mechanism, mounted in a frame with the lenticular array and/or lenticular array and substrate (100), etc., to facilitate such movements. This is illustrated as element 40 in Figs. 12 and 13, described

above. A hinge mechanism similar to that used in shower doors that enables the parts to move with respect to one another with low friction may be used, for example. The slide mechanism on rails may be similar to that used in drawers.

**[00105]** In certain examples, small, low cost linear motors and/or actuators may be available to control the lateral movement of the glass substrate with the solar cell strips. The motors and/or actuators may be miniature, in certain instances. Miniature linear actuators in some cases may be operated by small stepper motors. Small linear motors/actuators may also be used in low cost consumer electronics, automotive, and industrial applications. However, it will be appreciated that the lateral movement of substrate 200 may be controlled in any suitable manner.

**[00106]** Linear motors and/or actuators may be built into the frame of the assembly, in certain example embodiments. These motors and/or actuators may be controlled, in certain examples, by low cost microcontrollers. The controllers may be programmed to maintain relative orientation between a lenticular array and a glass substrate with solar strips disposed thereon, in order to maintain the focus of the sunlight, in certain examples.

**[00107]** This movement preferably is a low friction movement. Thus, the movement may require very little power. For example, in certain embodiments, a lateral movement step of from about 0.01 to 1 mm every 10 minutes is all that may be necessary to maintain the focus of the sunlight. Furthermore, the force requirement to move the glass may be low, particularly if the glass substrate is relatively thin (e.g., less than about 10 mm, more preferably less than about 5 mm, and most preferably from about 1 to 2 mm). In certain instances, the glass may be thick enough to reduce bowing, but thin enough to reduce weight. In some cases, power generated by the solar cells may be used to power this movement.

**[00108]** The dual and/or triple glazing assemblies described herein may not suffer from problems experienced by traditional concentrated photovoltaic system. In certain conventional concentrated photovoltaic systems (e.g., those

installed in the desert or the like), a rugged, robust, and expensive tracker system may be needed in order for the system to withstand windloads, other external forces, and certain acts of nature. However, in certain example embodiments of the assemblies disclosed herein, there may be no or few heavy external forces impacting the tracker system (e.g., wind, etc.). This is because the glass with the solar strips may be safely enclosed between the lenticular array and the inside of a building (e.g., in the case of a dual glazing unit), or even between a first and third glass substrate (e.g., in the case of a triple glazing unit, or a unit with even more substrates). It will be appreciated that the improved durability resulting from the double, triple, quad, etc., glazing is advantageous, and makes the assemblies described herein desirable for implementation into energy-efficient buildings.

**[00109]** Certain example assemblies disclosed herein may be installed at a latitude tilt as shown in Fig. 16, on the roof of buildings. The assemblies may be thermally insulating in certain example embodiments. Furthermore, the assemblies may advantageously have a low solar heat gain coefficient for direct sunlight. Additionally, in certain examples, the diffuse light/daylight that enters a building through the assembly may reduce the need for artificial lighting. In view of these features, the cost of heating and cooling the building may advantageously be kept low.

**[00110]** In certain example embodiments, the installation of an example assembly may be particularly advantageous in southern locations (in the northern hemisphere), locations near the equator, and in northern locations in the southern hemisphere (though one skilled in the art will understand the modifications to this system if implemented in locations other than the northern hemisphere). In certain instances, installing an assembly at a latitude tilt, facing the equator, may advantageously give more annual energy output than a vertical façade system. In other words, the assemblies described herein may be particularly advantageous in warmer climates, e.g., with an abundance of direct

sunlight. However, the applicability of these assemblies is widespread and they may be used in any climate or region.

[00111] The table below shows example energy output data for Phoenix, at a 33.43 degree latitude. The calculations in Table 4 were calculated using the NREL PVWatts calculator.

Table 4: Simulated Results of Installation at Latitude Tilt v. Vertical Installation

Month	Results at Latitude Tilt			Results of Vertical Installation		
	Solar Radiation kWh/m2/day	AC Energy (kWh)	Energy Value (\$)	Solar Radiation kWh/m2/day	AC Energy (kWh)	Energy Value (\$)
1	5.09	451	38.34	4.79	427	36.30
2	6.05	486	41.31	5.04	408	34.68
3	6.61	566	48.11	4.38	363	30.86
4	7.54	613	52.11	3.72	273	23.21
5	7.54	619	52.62	2.70	178	15.13
6	7.28	559	47.52	2.26	132	11.22
7	7.14	569	48.37	2.47	156	13.26
8	7.17	576	48.96	3.17	220	18.70
9	7.15	557	47.34	4.31	318	27.03
10	6.75	565	48.02	5.33	447	37.99
11	5.59	469	39.87	5.14	435	36.98
12	4.88	438	37.23	4.85	437	37.15
Year Total	6.57	6468	549.78	4.01	3794	322.49

Table 5: Station Identification

Station Identification	
City:	Phoenix
State:	Arizona
Latitude:	33.43° N
Longitude:	112.02° W
Elevation:	339 m
PV System Specifications	
DC rating:	4.0 kW
DC to AC Derate Factor:	0.77
AC Rating:	3.1 kW
Array Tilt:	33.4° or 90°
Array Azimuth:	180.0°
Energy Specifications	

Cost of Electricity:	\$0.085/kWh
----------------------	-------------

**[00112]** The 4kW system of Table 5 uses about 25-50 m<sup>2</sup> of (BIPV) skylight area if the efficiency for direct sunlight is 10-20%, in certain examples.

**[00113]** Certain example assemblies, e.g., of Figs. 11, 12, and/or 13 and/or 14, may function as a self-regulating window, in certain example embodiments. For example, substantially only diffuse daylight may be transmitted through the substrates into the structure upon which the assembly is disposed, in certain example embodiments. The diffuse daylight may constitute about 15% of the total maximum irradiation from the sun, in certain example embodiments. In certain example situations, the amount of diffuse daylight may remain substantially constant regardless of the sun's position throughout the course of a day. During cloudy or inclement weather, or when the sun moves temporarily behind a cloud, an assembly may still transmit most of the light to the interior of a building, since most of it (or even all of it in certain instances) is diffuse. When the sun reappears, the total irradiation may increase by a factor of about 6, although the photovoltaic skylight system may advantageously only transmit about the same amount of light (e.g., 15% of the total). In other words, in certain instances the assembly may selectively block direct solar radiation only (e.g., because the solar radiation is absorbed by the solar strips). Thus, the assembly may have a variable solar heat gain control, in that it blocks most of the heat associated with direct sunlight (again, e.g., because the direct solar radiation – such as that from direct sunlight – is absorbed before it can be transmitted through the bottom substrate). Certain example assemblies may thus permit a reduction in electricity bills for air-conditioning.

**[00114]** Furthermore, because of the direct sunlight being absorbed by the solar cell strips (e.g., for the generation of electricity), diffuse daylight is the primary light entering the building. This may help reduce the glare from direct

sunlight. The transmitted diffuse daylight may reduce the need for artificial lighting in the building, without substantially increasing the ambient temperature within the building. In other words, integrating example embodiments of assemblies described herein, e.g., as a skylight, window, or the like, in a building may advantageously increase lighting within the building without increasing the temperature, decrease the need for artificial lighting, and of course, provide an additional source of electricity. Accordingly, certain example assemblies described herein may reduce energy usage and/or utility costs in multiple ways. In addition, daylight tends to promote health and productivity of the occupants of a building, as shown in many studies.

**[00115]** As described above, certain example embodiments assemblies described herein (e.g., windows, skylights, dual and/or triple glazings, etc.) may advantageously provide a degree of thermal insulation in certain example embodiments. Certain example assemblies described herein may be double or triple glazing units. In this regard, in some cases, an additional degree of thermal insulation may be provided as a result.

**[00116]** Further, to provide additional thermal insulation for a building, low-emissivity coatings may be provided on one or more of the interior glass surfaces. In certain example embodiments, the degree of additional thermal insulation provided may advantageously enable the cost of heating to be reduced. This may also advantageously reduce utility bills, energy usage, etc. Additional example low-E coatings are described in U.S. Patent Nos. 6,686,050, 6,723,211, 6,782,718, 6,749,941, 6,730,352, 6,802,943, 4,782,216, 3,682,528, and 6,936,347, the disclosures of which are hereby incorporated herein by reference.

**[00117]** In certain example embodiments, if it is desired that more light reach the interior of the building (e.g., temporarily), the system may be programmed to move the solar cell strips out of the focus line of the solar light. This may be occasionally valuable in providing increased light (daylight), including direct solar radiation, to the interior of the building. However, in this

situation, the production of electricity may be reduced and/or stopped, in certain examples. This is simply an additional advantage related to certain example aspects of the assemblies disclosed herein.

**[00118]** Thus, it will be appreciated that certain example assemblies described herein may advantageously be installed at a latitude tilt, and therefore may have increased electricity output, the assemblies may provide daylight entry into the building, and also may also provide thermal insulation (e.g., as a dual and/or triple glazing). Furthermore, certain assemblies may also advantageously provide self-regulating or dynamic solar heat control, and a low solar heat gain coefficient if and/or when needed under direct sunlight.

**[00119]** In certain example embodiments, the multi-functionality of example assemblies described herein may cause these assemblies to be a much more attractive building-integrated photovoltaic system than existing/conventional BIPV systems. In some circumstances, electricity generation by itself may not be seen as enough of a benefit to justify an investment in BIPV technology. However, by adding thermal insulation, variable solar heat gain control, and diffuse daylight entry, certain example embodiments of the assemblies of or including improved BIPV systems described herein (e.g., windows, skylights, etc., comprising double and/or triple glazings, insulating glass units, and the like) may provide a more comprehensive solution for energy efficient buildings.

**[00120]** It will be appreciated that the improved BIPV systems disclosed herein may be used in connection with an IGU-inclusive photovoltaic skylight) and may be installed on commercial roofs, for example, roofs of factories, warehouses, office buildings, large stores, schools, shopping centers, etc. For example, an IGU-inclusive photovoltaic skylight system may be advantageous in any scenario where a combination of electricity generation, thermal insulation, solar heat gain control, and/or daylight entry may reduce the utility and/or operational costs of the building.

**[00121]** Figs. 17(a)-(e) show, schematically, a view of an example multifunctional BIPV concentrating solar photovoltaic skylight 1700 in accordance with certain example embodiments. More particularly, Fig. 17(a) is a front view thereof, Fig. 17(b) is an isometric view thereof, Fig. 17(c) is a view through section A—A of Fig. 17(a), Fig. 17(d) is a view through section B—B of Fig. 17(a), and Fig. 17(e) is an enlargement of detail C from Fig. 17(b). First, second, and third substrates 1702, 1704, and 1706 are provided, in this order, from exterior to interior. The first substrate 1702 may be a cover glass substrate, the second substrate 1704 may be an actuating inner optical glass substrate in certain example embodiments (e.g., it may include or support the lenticular array), and/or the third substrate 1706 may support the strip solar cells. However, in certain different example embodiments, the first substrate 1702 may include or support the lenticular array while the second glass substrate supports the strip solar cells and is movable relative to the fixed lenticular array. In such cases, the third substrate 1706 may be a protective substrate. The exterior frame 1708 may be provided between the first and third substrates 1702 and 1706 and help to keep them in substantially parallel and spaced apart relation to one another. It also may directly or indirectly support the second glass substrate 1704, e.g., via the servo motor.

**[00122]** For instance, in certain example embodiments, a pin 1710 may connect the second glass substrate 1704 to a body portion 1712 of the servo motor. When the servo motor is actuated, it will cause the servo motor rod 1714 (which may include magnets in certain example embodiments) to expand or contract, causing the second substrate 1706 that is connected thereto via the pin 1710 to be correspondingly displaced. Movement may be facilitated by providing one or more sliders 1716 that roll on or otherwise travel along a compact rail 1718 disposed on one or both sides thereof.

**[00123]** As alluded to above, the servo motor may be a linear motor inside of the frame that helps control the lateral movement of the second substrate 1704. A microcontroller may be programmed to cause the servo motor to

move, e.g., based on the time of day and/or based on feedback from a photo-detector or the like. The total movement may be about 1 cm during the day based on, for example the latitude tilt or the like. The movement may take place slowly, e.g., about 0.01 to 0.1 mm once every 10 min. to accomplish the full movement throughout the day, thereby enabling the servo to consume a low amount of power. Advantageously, the system is protected by the inner and outer first and third substrates 1702 and 1706. Thus, the need to protect the system from external forces (e.g., high winds, hail, etc.) is reduced.

**[00124]** As indicated above, the skylight advantageously becomes self-regulating. In some cases, only about 15% of the total maximum irradiation, which corresponds to diffuse light, is transmitted into the building. Direct solar radiation is blocked, thereby enabling variable solar heat gain control, e.g., such that heat is blocked when most appropriate (e.g., under full sunlight), which can in turn lead to heating/cooling advantages, etc.

**[00125]** As indicated above, certain example embodiments may include low-iron glass. The total amount of iron present is expressed herein in terms of  $\text{Fe}_2\text{O}_3$  in accordance with standard practice. However, typically, not all iron is in the form of  $\text{Fe}_2\text{O}_3$ . Instead, iron is usually present in both the ferrous state ( $\text{Fe}^{2+}$ ; expressed herein as FeO, even though all ferrous state iron in the glass may not be in the form of FeO) and the ferric state ( $\text{Fe}^{3+}$ ). Iron in the ferrous state ( $\text{Fe}^{2+}$ ; FeO) is a blue-green colorant, while iron in the ferric state ( $\text{Fe}^{3+}$ ) is a yellow-green colorant. The blue-green colorant of ferrous iron ( $\text{Fe}^{2+}$ ; FeO) is of particular concern when seeking to achieve a fairly clear or neutral colored glass, since as a strong colorant it introduces significant color into the glass. While iron in the ferric state ( $\text{Fe}^{3+}$ ) is also a colorant, it is of less concern when seeking to achieve a glass fairly clear in color since iron in the ferric state tends to be weaker as a colorant than its ferrous state counterpart.

**[00126]** In certain example embodiments of this invention, a glass is made so as to be highly transmissive to visible light, to be fairly clear or neutral in color, and to consistently realize high %TS values. High %TS values are

particularly desirable for photovoltaic device applications in that high %TS values of the light-incident-side glass substrate permit such photovoltaic devices to generate more electrical energy from incident radiation since more radiation is permitted to reach the semiconductor absorbing film of the device. It has been found that the use of an extremely high batch redox in the glass manufacturing process permits resulting low-ferrous glasses made via the float process to consistently realize a desirable combination of high visible transmission, substantially neutral color, and high total solar (%TS) values. Moreover, in certain example embodiments of this invention, this technique permits these desirable features to be achieved with the use of little or no cerium oxide.

**[00127]** In certain example embodiments of this invention, a soda-lime-silica based glass is made using the float process with an extremely high batch redox. An example batch redox which may be used in making glasses according to certain example embodiments of this invention is from about +26 to +40, more preferably from about +27 to +35, and most preferably from about +28 to +33 (note that these are extremely high batch redox values not typically used in making glass). In making the glass via the float process or the like, the high batch redox value tends to reduce or eliminate the presence of ferrous iron ( $\text{Fe}^{2+}$ ;  $\text{FeO}$ ) in the resulting glass, thereby permitting the glass to have a higher %TS transmission value which may be beneficial in photovoltaic applications. This is advantageous, for example, in that it permits high transmission, neutral color, high %TS glass to be made using raw materials having typical amounts of iron in certain example instances (e.g., from about 0.04 to 0.10% total iron). In certain example embodiments of this invention, the glass has a total iron content ( $\text{Fe}_2\text{O}_3$ ) of no more than about 0.1%, more preferably from about 0 (or 0.04) to 0.1%, even more preferably from about 0.01 (or 0.04) to 0.08%, and most preferably from about 0.03 (or 0.04) to 0.07%. In certain example embodiments of this invention, the resulting glass may have a %FeO (ferrous iron) of from 0 to 0.0050%, more preferably from 0

to 0.0040, even more preferably from 0 to 0.0030, still more preferably from 0 to 0.0020, and most preferably from 0 to 0.0010, and possibly from 0.0005 to 0.0010 in certain example instances. In certain example embodiments, the resulting glass has a glass redox (different than batch redox) of no greater than 0.08, more preferably no greater than 0.06, still more preferably no greater than 0.04, and even more preferably no greater than 0.03 or 0.02.

**[00128]** In certain example embodiments, the glass substrate may have fairly clear color that may be slightly yellowish (a positive  $b^*$  value is indicative of yellowish color), in addition to high visible transmission and high %TS. For example, in certain example embodiments, the glass substrate may be characterized by a visible transmission of at least about 90% (more preferably at least about 91%), a total solar (%TS) value of at least about 90% (more preferably at least about 91%), a transmissive  $a^*$  color value of from -1.0 to +1.0 (more preferably from -0.5 to +0.5, even more preferably from -0.35 to 0), and a transmissive  $b^*$  color value of from -0.5 to +1.5 (more preferably from 0 to +1.0, and most preferably from +0.2 to +0.8). These properties may be realized at an example non-limiting reference glass thickness of about 4 mm.

**[0001]** In certain example embodiments of this invention, there is provided a method of making glass comprising:

Ingredient	wt. %
SiO <sub>2</sub>	67 – 75 %
Na <sub>2</sub> O	10 – 20 %
CaO	5 – 15 %
total iron (expressed as Fe <sub>2</sub> O <sub>3</sub> )	0.001 to 0.1 %
%FeO	0 to 0.005

wherein the glass has visible transmission of at least about 90%, a transmissive  $a^*$  color value of -1.0 to +1.0, a transmissive  $b^*$  color value of from -0.50 to +1.5, %TS of at least 89.5%, and wherein the method comprises using a batch redox of from +26 to +40 in making the glass.

**[0002]** In certain example embodiments of this invention, there is provided a glass comprising:

Ingredient	wt. %
SiO <sub>2</sub>	67 – 75 %
Na <sub>2</sub> O	10 – 20 %
CaO	5 – 15 %
total iron (expressed as Fe <sub>2</sub> O <sub>3</sub> )	<= 0.1 %
%FeO	<= 0.005
glass redox	<= 0.08
antimony oxide	0 to less than 0.01 %
cerium oxide	0 to 0.07 %

wherein the glass has visible transmission of at least 90%, TS transmission of at least 90%; a transmissive a\* color value of -1.0 to +1.0, a transmissive b\* color value of from -0.5 to +1.5.

**[0003]** In still further example embodiments of this invention, there is provided solar cell comprising: a glass substrate; first and second conductive layers with at least a photoelectric film provided therebetween; wherein the glass substrate is of a composition comprising:

Ingredient	wt. %
SiO <sub>2</sub>	67 – 75 %
Na <sub>2</sub> O	10 – 20 %
CaO	5 – 15 %
total iron (expressed as Fe <sub>2</sub> O <sub>3</sub> )	<= 0.1 %
%FeO	<= 0.005
glass redox	<= 0.08
antimony oxide	0 to less than 0.01 %
cerium oxide	0 to 0.07 %

wherein the glass substrate has visible transmission of at least 90%, TS transmission of at least 90%; a transmissive a\* color value of -1.0 to +1.0, a transmissive b\* color value of from -0.5 to +1.5.

**[00129]** As used herein, the terms “on,” “supported by,” and the like should not be interpreted to mean that two elements are directly adjacent to one another unless explicitly stated. In other words, a first layer may be said to be “on” or “supported by” a second layer, even if there are one or more layers therebetween.

**[00130]** In certain example embodiments, a skylight is provided. A plurality of elongate solar cells are supported by a substrate. A lens array comprises a plurality of lenses oriented along a common axis, with each said lens being configured to concentrate light on the elongate solar cells, and with the lens array being substantially parallel to and spaced apart from the substrate such that a gap is defined between the lens array and the substrate. The skylight is arranged to permit some diffuse light incident thereon to pass therethrough and to cause direct light to be focused onto the solar cells.

**[00131]** In addition to the features of the previous paragraph, in certain example embodiments, the skylight may be substantially horizontally disposable on a roof.

**[00132]** In addition to the features of either of the two previous paragraphs, in certain example embodiments, the skylight may be orientable at a tilt selected in dependence on a latitude where the skylight is to be installed.

**[00133]** In addition to the features of any of the three previous paragraphs, in certain example embodiments, the solar cells may comprise c-Si.

**[00134]** In addition to the features of any of the four previous paragraphs, in certain example embodiments, the solar cells may have an aspect ratio of at least about 2:1.

**[00135]** In addition to the features of any of the five previous paragraphs, in certain example embodiments, the solar cells may have an aspect ratio of at least about 5:1.

**[00136]** In addition to the features of any of the six previous paragraphs, in certain example embodiments, a movement mechanism may be configured to move the substrate supporting the solar cells relative to the lens array

**[00137]** In addition to the features of the previous paragraph, in certain example embodiments, the substrate supporting the solar cells may have a substantially horizontal range of motion of up to about 20 mm.

**[00138]** In addition to the features of any of the eight previous paragraphs, in certain example embodiments, first and second edge seals may be provided, with each of the edge seals optionally including first and second openings into which first and second edges of the substrate and the lens array may be inserted, respectively.

**[00139]** In addition to the features of any of the nine previous paragraphs, in certain example embodiments, a motor may be provided, and the first openings of the first and second edge seals may be spaced apart a distance greater than a length of the substrate such that the substrate is slidable along an axis under control of the motor.

**[00140]** In addition to the features of any of the ten previous paragraphs, in certain example embodiments, the skylight may be arranged to be installed at a latitude tilt of from about 5 to 50 degrees, more preferably from about 15 to 45 degrees.

**[00141]** In addition to the features of any of the eleven previous paragraphs, in certain example embodiments, a motor and/or actuator for controlling lateral movement of the substrate supporting the solar cells may be provided.

**[00142]** In certain example embodiments, a method of making a building-integrated photovoltaic skylight is provided. A substrate supports a plurality of spaced apart, generally elongate solar cells. A lens array comprises a plurality of lenses oriented along a common axis. The substrate and the lens array are connected to one another such that each said lens is configured to concentrate light incident thereon towards the elongate solar cells and such that the lens array is substantially parallel to and spaced apart from the substrate.

**[00143]** In addition to the features of the previous paragraph, in certain example embodiments, the photovoltaic skylight may include another substrate

provided in spaced apart relation to the substrate supporting the solar cells on a surface opposite the lens array.

**[00144]** In addition to the features of either of the two previous paragraphs, in certain example embodiments, the solar cells may comprise c-Si.

**[00145]** In addition to the features of any of the three previous paragraphs, in certain example embodiments, the solar cells may have an aspect ratio of at least about 2:1, more preferably at least about 5:1.

**[00146]** In addition to the features of any of the four previous paragraphs, in certain example embodiments, the skylight may be installable at a latitude tilt such that it is angled toward the equator.

**[00147]** In addition to the features of any of the five previous paragraphs, in certain example embodiments, a motor and/or actuator may be provided for laterally moving the substrate supporting the solar cells.

**[00148]** In addition to the features of the previous paragraph, in certain example embodiments, the substrate supporting the solar cells may have a range of lateral motion of up to about 20 mm.

**[00149]** While the invention has been described in connection with what is presently considered to be the most practical and preferred embodiment, it is to be understood that the invention is not to be limited to the disclosed embodiment, but on the contrary, is intended to cover various modifications and equivalent arrangements included within the spirit and scope of the appended claims.

## WHAT IS CLAIMED IS:

1. A skylight, comprising:  
a plurality of elongate solar cells supported by a substrate; and  
a lens array comprising a plurality of lenses oriented along a common axis, each said lens being configured to concentrate light on the elongate solar cells, the lens array being substantially parallel to and spaced apart from the substrate such that a gap is defined between the lens array and the substrate,  
the skylight being arranged to permit some diffuse light incident thereon to pass therethrough and to cause direct light to be focused onto the solar cells.
2. The photovoltaic skylight of claim 1, wherein the skylight is substantially horizontally disposable on a roof.
3. The photovoltaic skylight of any preceding claim, wherein the skylight is orientable at a tilt selected in dependence on a latitude where the skylight is to be installed.
4. The photovoltaic skylight of any preceding claim, wherein the solar cells comprise c-Si.
5. The photovoltaic skylight of any preceding claim, wherein the solar cells have an aspect ratio of at least about 2:1.
6. The photovoltaic skylight of any preceding claim, wherein the solar cells have an aspect ratio of at least about 5:1.
7. The photovoltaic skylight of any preceding claim, further comprising a movement mechanism configured to move the substrate supporting the solar cells relative to the lens array
8. The photovoltaic skylight of any preceding claim, wherein the substrate supporting the solar cells has a substantially horizontal range of motion of up to about 20 mm.
9. The photovoltaic skylight of any preceding claim, further comprising first and second edge seals, each of the edge seals including first

and second openings into which first and second edges of the substrate and the lens array are inserted, respectively.

10. The photovoltaic skylight of any preceding claim, further comprising a motor,

wherein the first openings of the first and second edge seals are spaced apart a distance greater than a length of the substrate such that the substrate is slidable along an axis under control of the motor.

11. The photovoltaic skylight of any preceding claim, wherein the skylight is arranged to be installed at a latitude tilt of from about 5 to 50 degrees.

12. The photovoltaic skylight of any preceding claim, wherein the skylight is arranged to be installed at a latitude tilt of from about 15 to 45 degrees.

13. The photovoltaic skylight of any preceding claim, further comprising a motor and/or actuator for controlling lateral movement of the substrate supporting the solar cells.

14. A method of making a building-integrated photovoltaic skylight, the method comprising:

providing a substrate supporting a plurality of spaced apart, generally elongate solar cells;

providing a lens array comprising a plurality of lenses oriented along a common axis; and

connecting the substrate and the lens array to one another such that each said lens is configured to concentrate light incident thereon towards the elongate solar cells and such that the lens array is substantially parallel to and spaced apart from the substrate.

15. The method of claim 14, wherein the photovoltaic skylight includes another substrate provided in spaced apart relation to the substrate supporting the solar cells on a surface opposite the lens array.

16. The method of any of claims 14-15, wherein the solar cells comprise c-Si.
17. The method of any of claims 14-16, wherein the solar cells have an aspect ratio of at least about 2:1.
18. The method of any of claims 14-17, wherein the solar cells have an aspect ratio of at least about 5:1.
19. The method of any of claims 14-18, wherein the skylight is installable at a latitude tilt such that it is angled toward the equator.
20. The method of any of claims 14-19, further comprising providing a motor and/or actuator for laterally moving the substrate supporting the solar cells.
21. The method of claim 20, wherein the substrate supporting the solar cells has a range of lateral motion of up to about 20 mm.

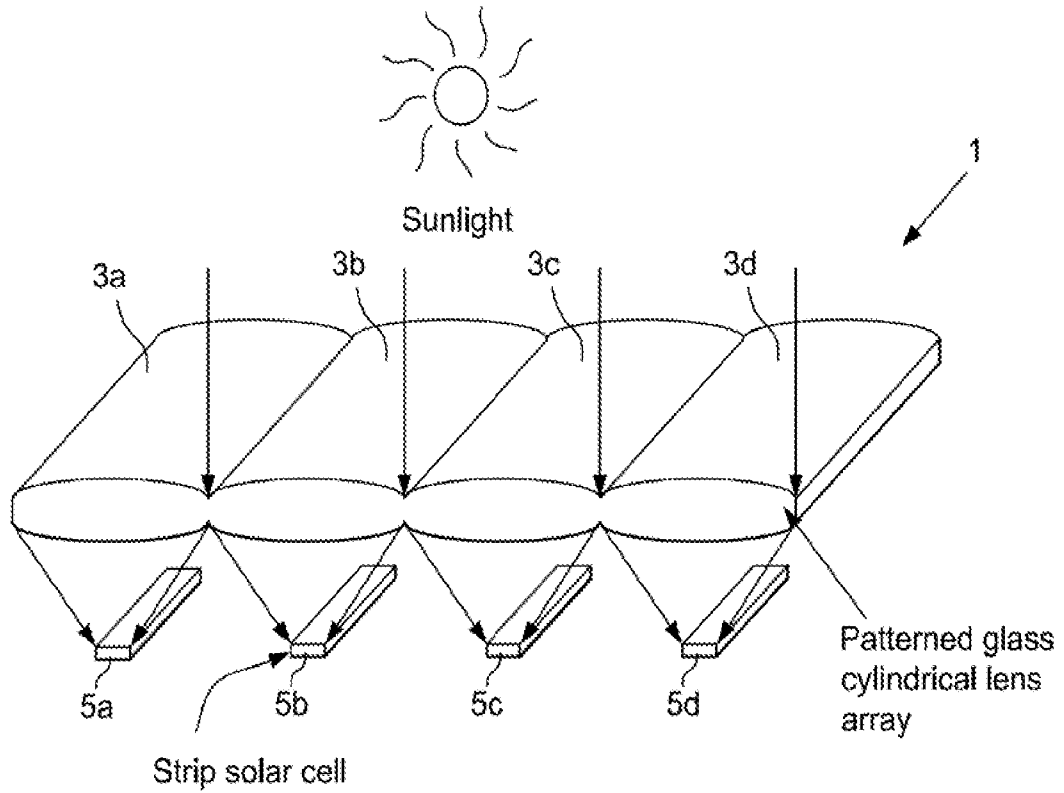

FIG. 1

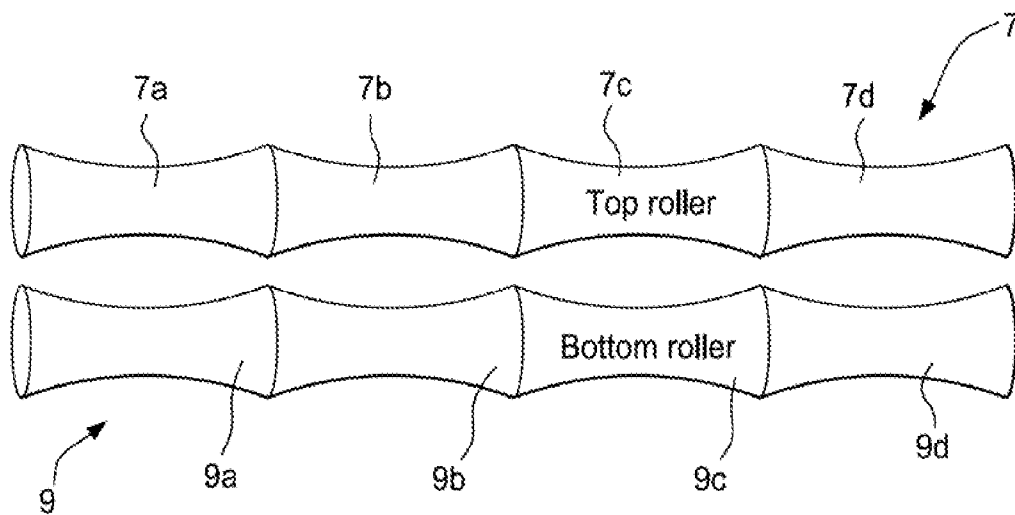
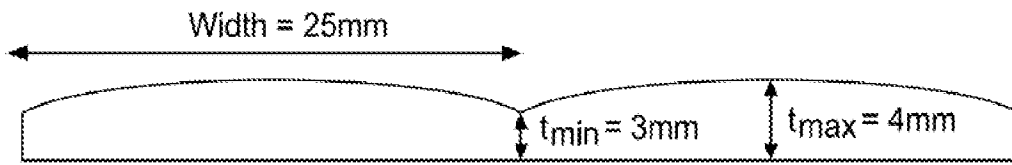
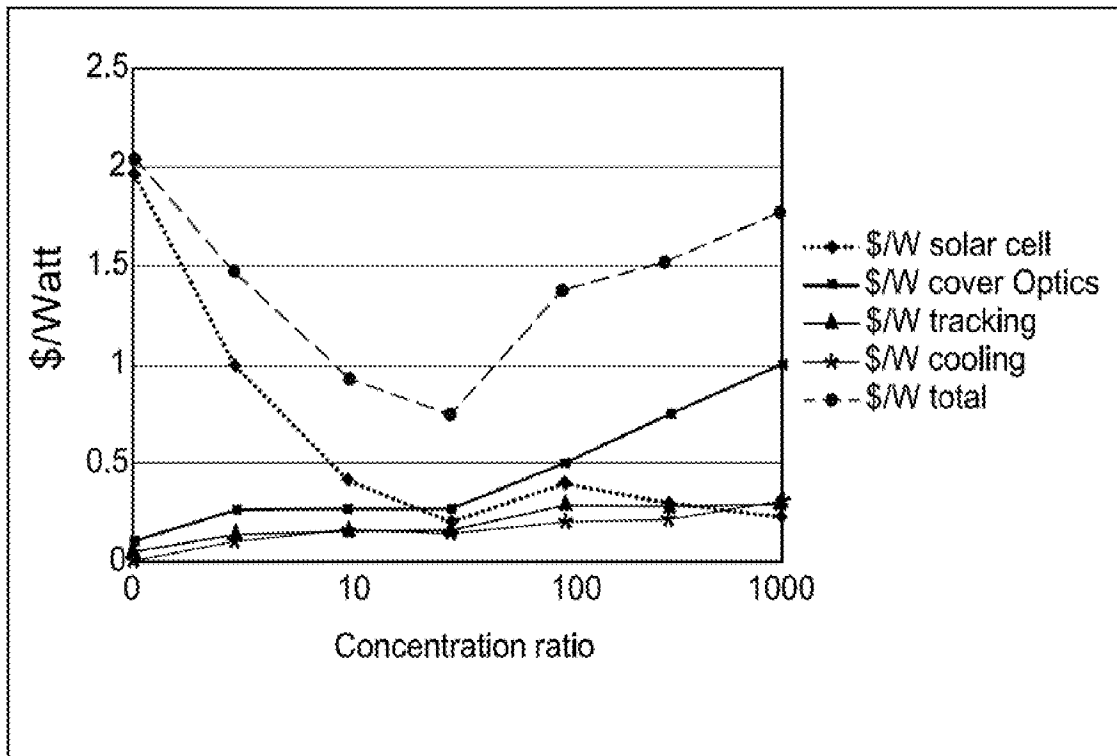

FIG. 2



**FIG. 3**



**FIG. 4**

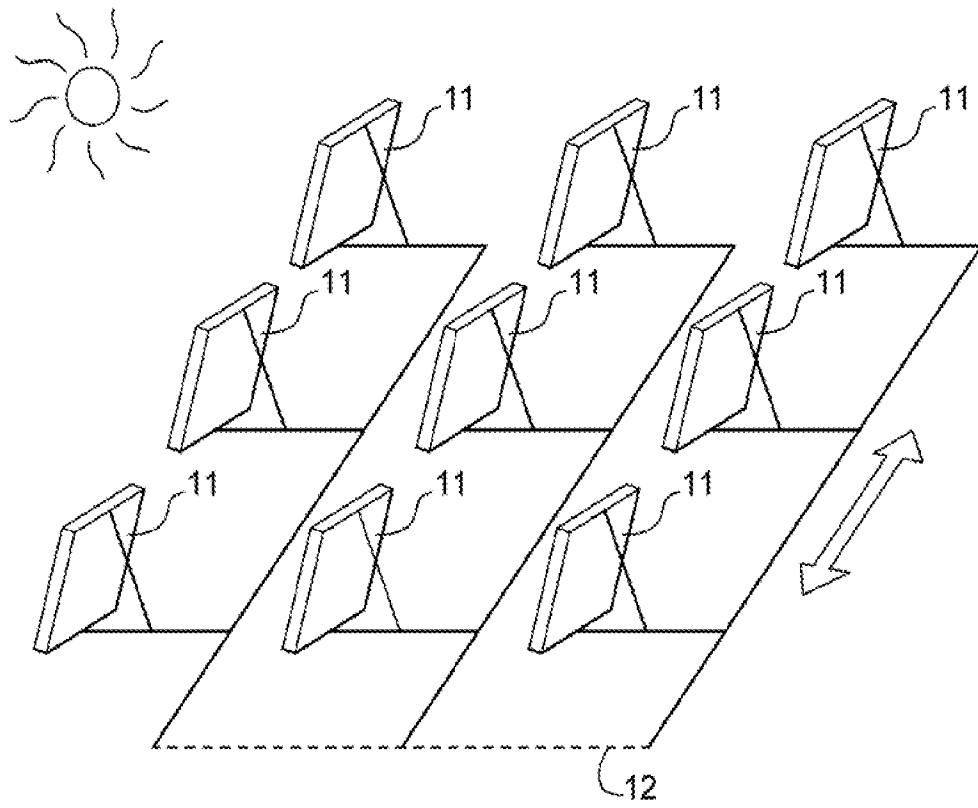

FIG. 5

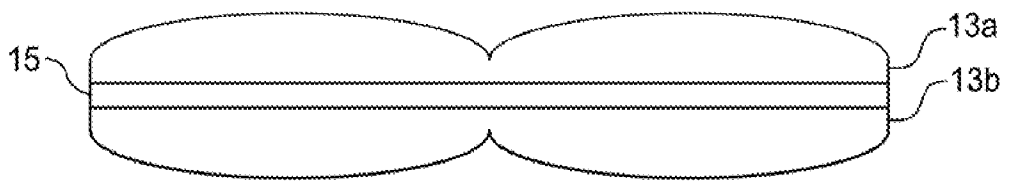

FIG. 6

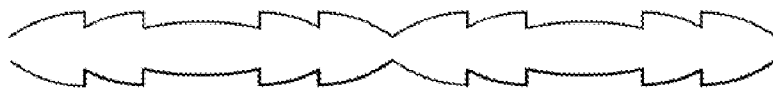
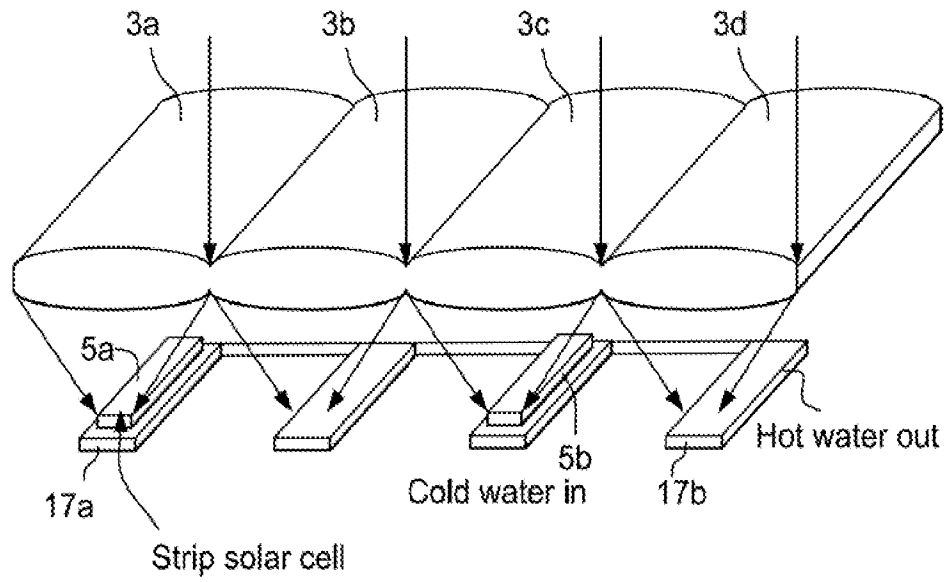
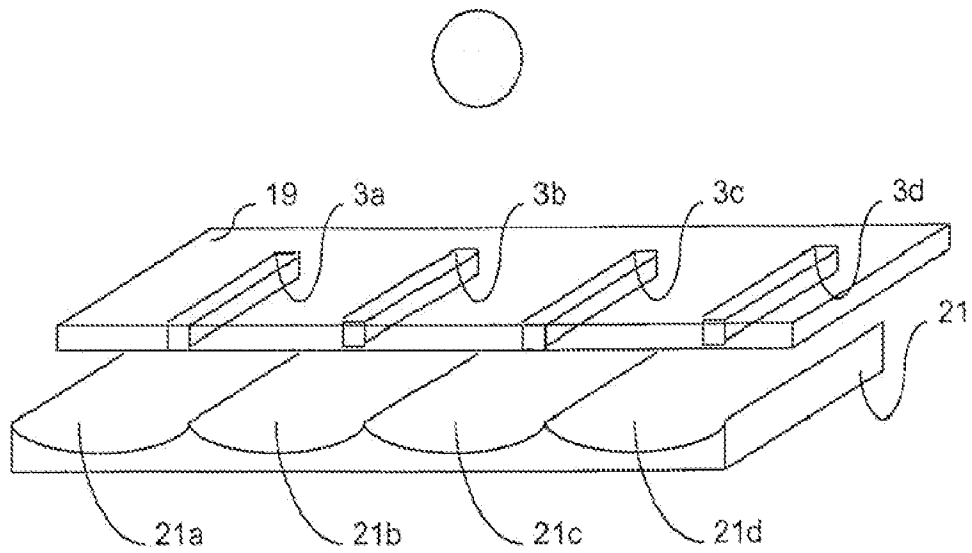

FIG. 7



**FIG. 8**



**FIG. 9**

5/15

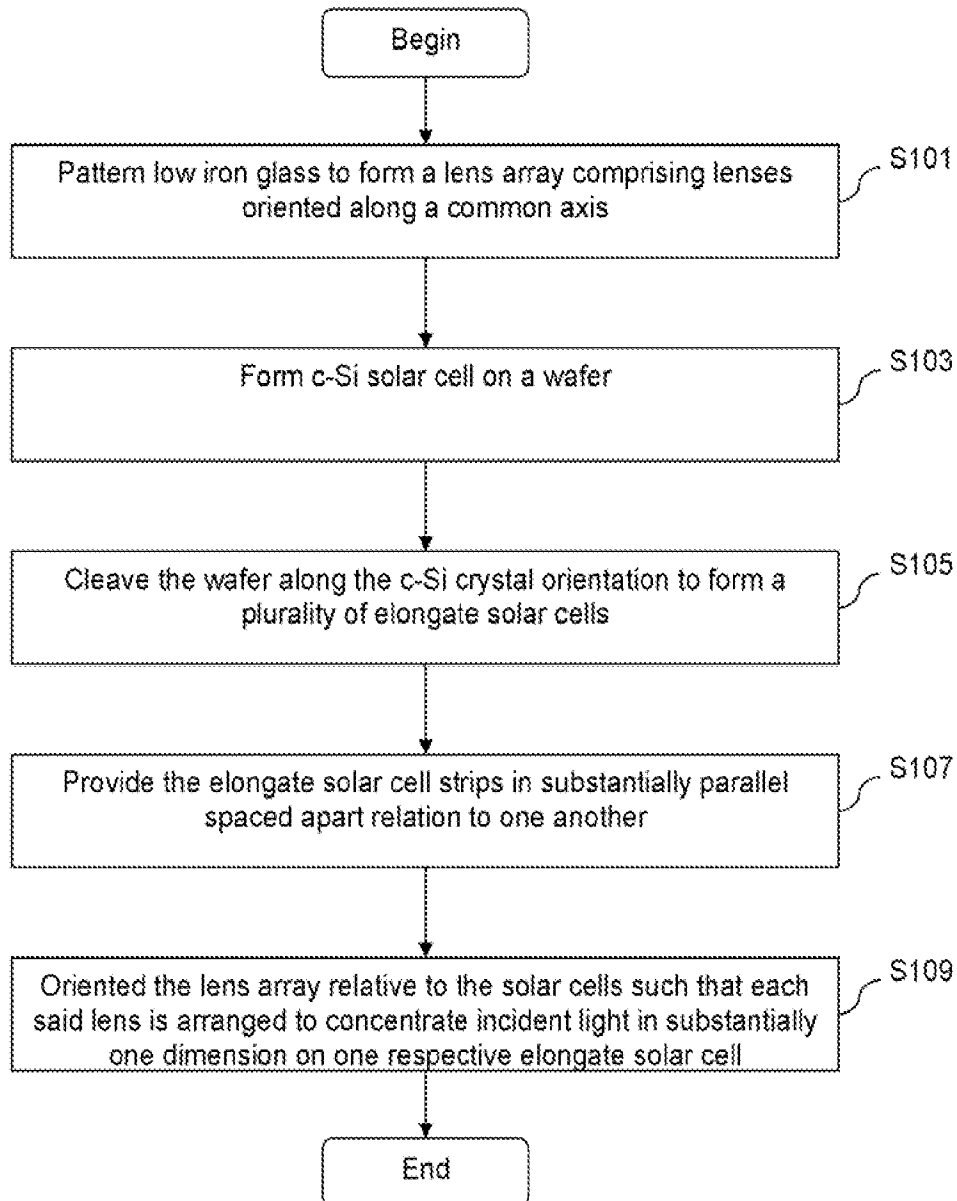

Fig. 10

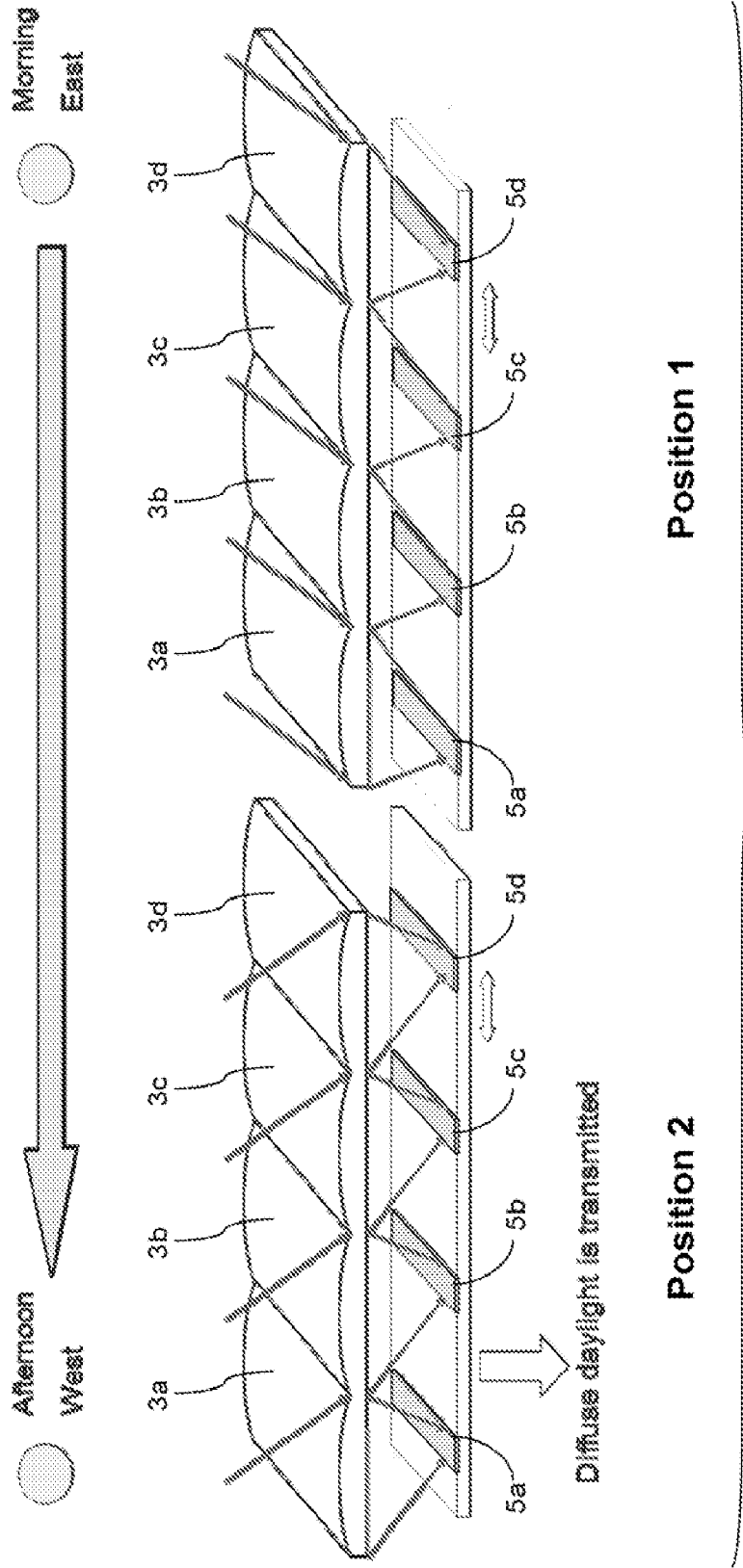

Fig. 11

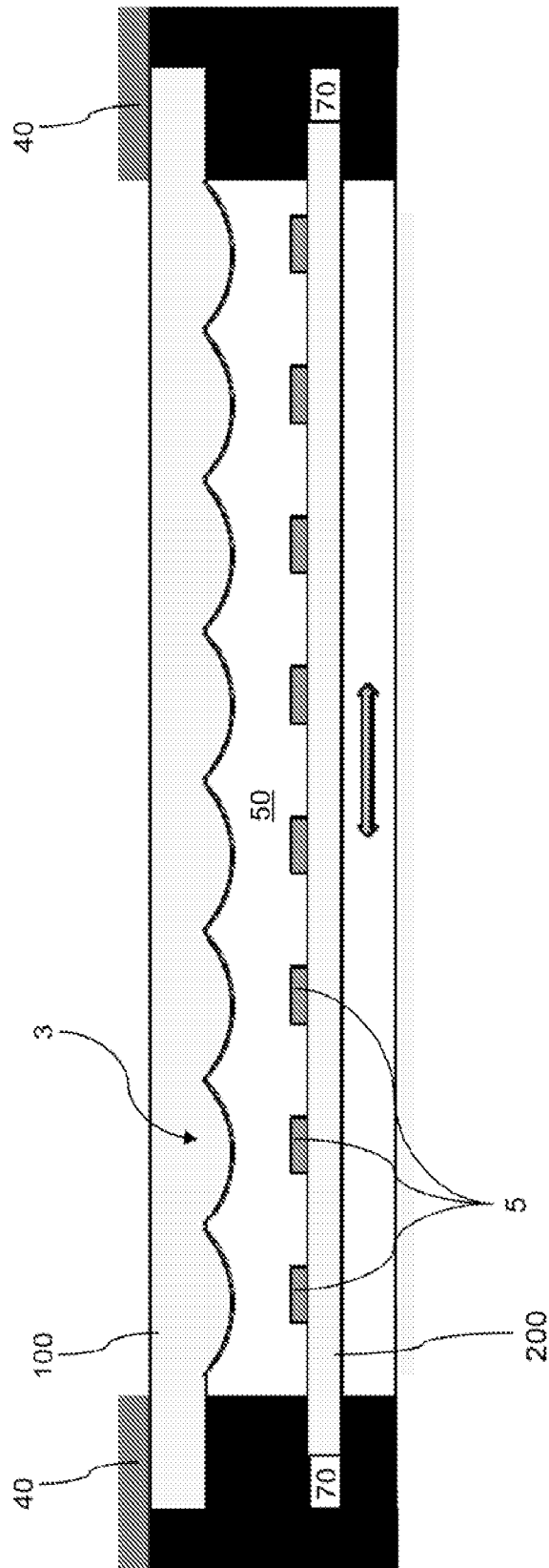

Fig. 12

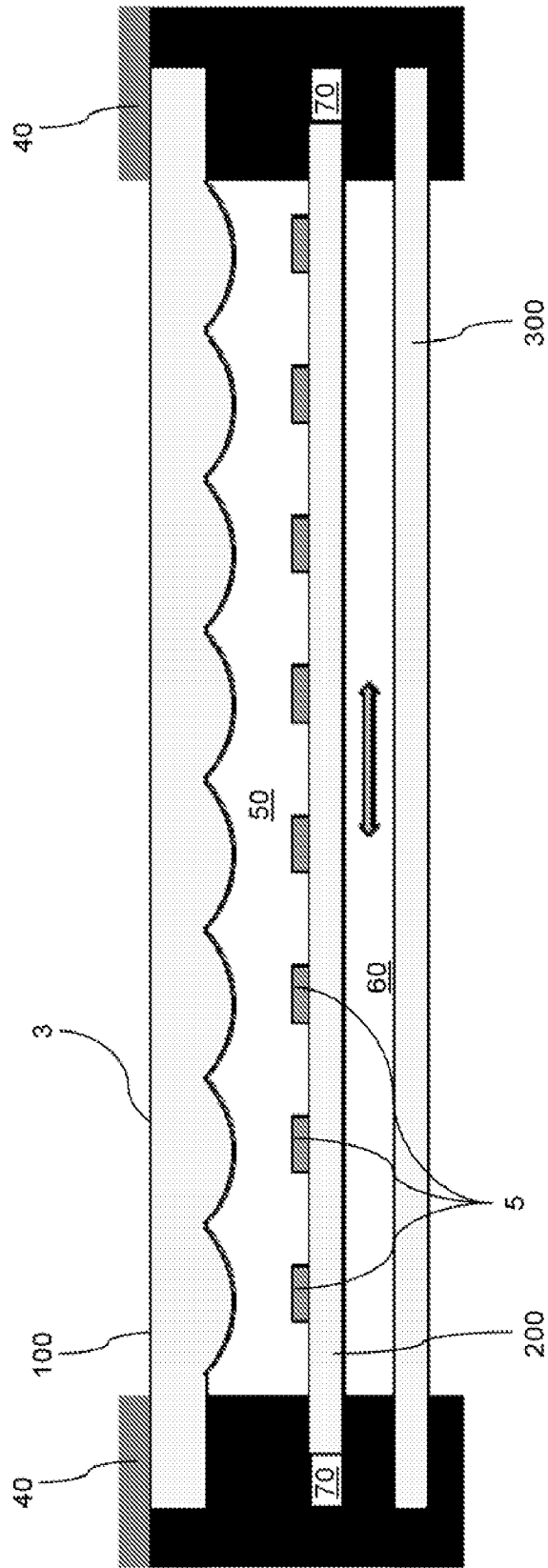

Fig. 13

9/15

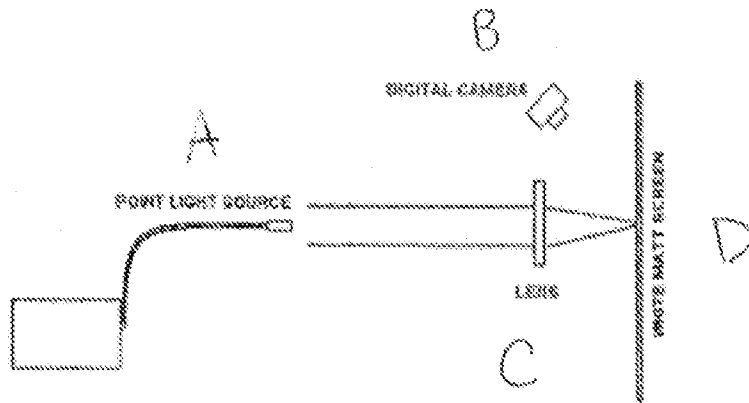

Fig. 14(a)

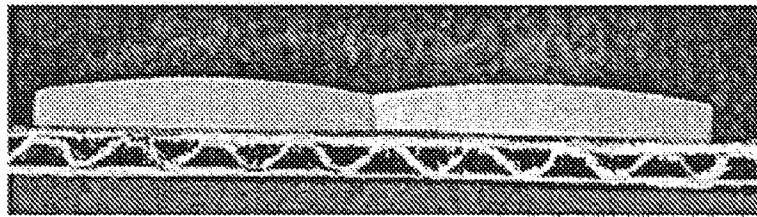

Fig. 14(b)

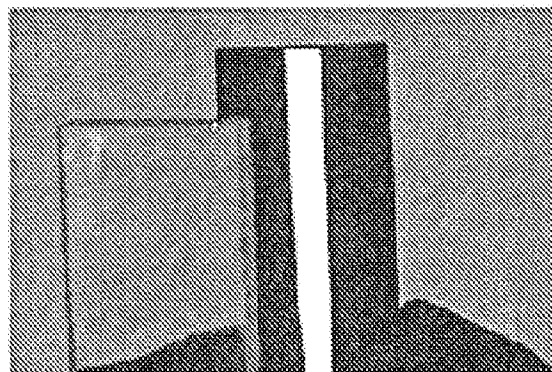

Fig. 14(c)

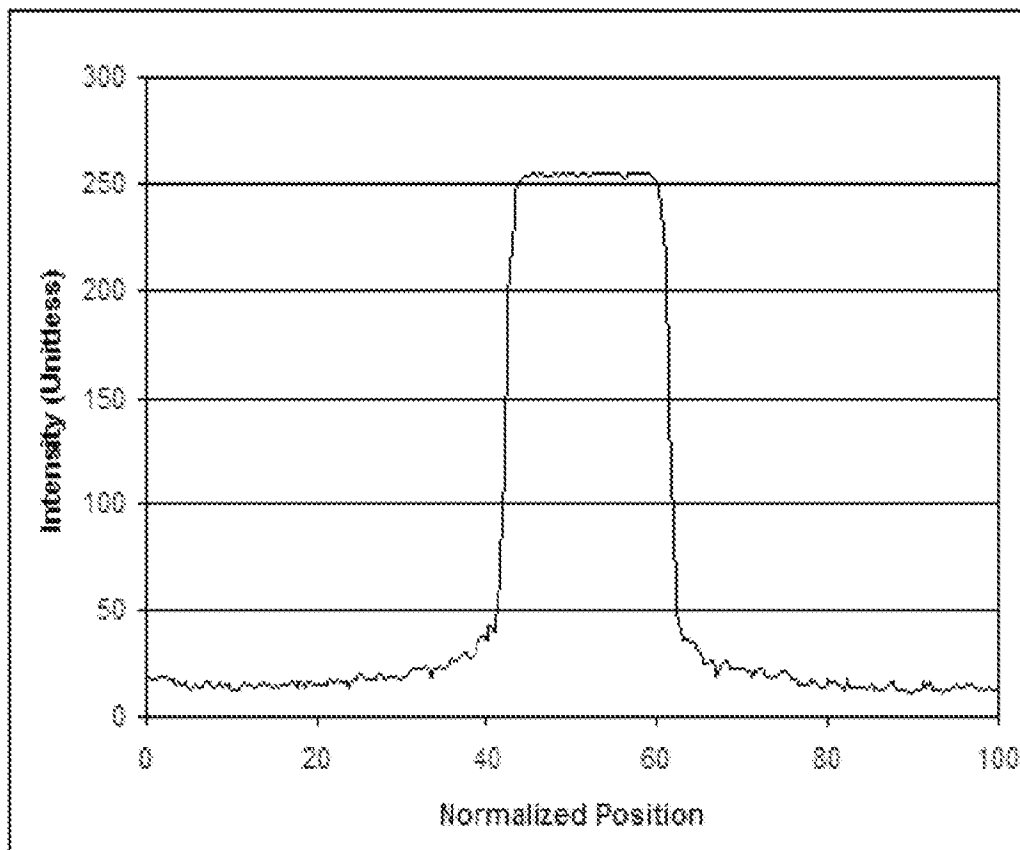

Fig. 14(d)

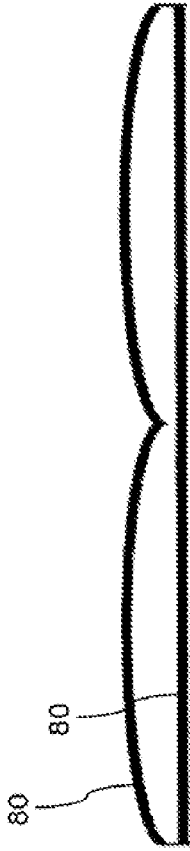

Fig. 15(a)



Fig. 15(b)

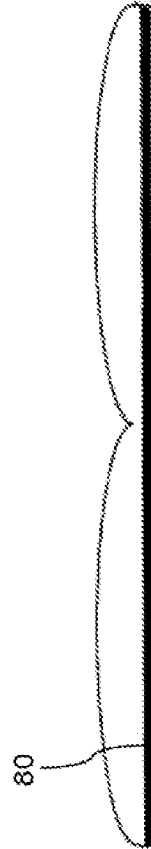

Fig. 15(c)

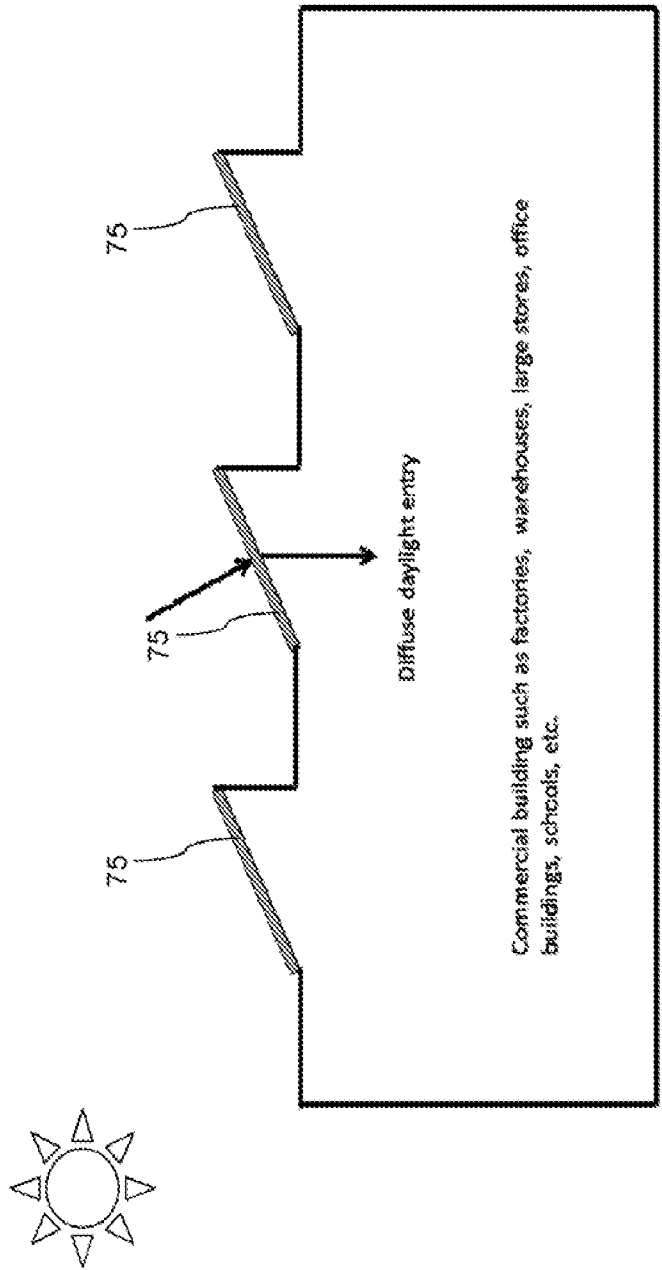

Fig. 16

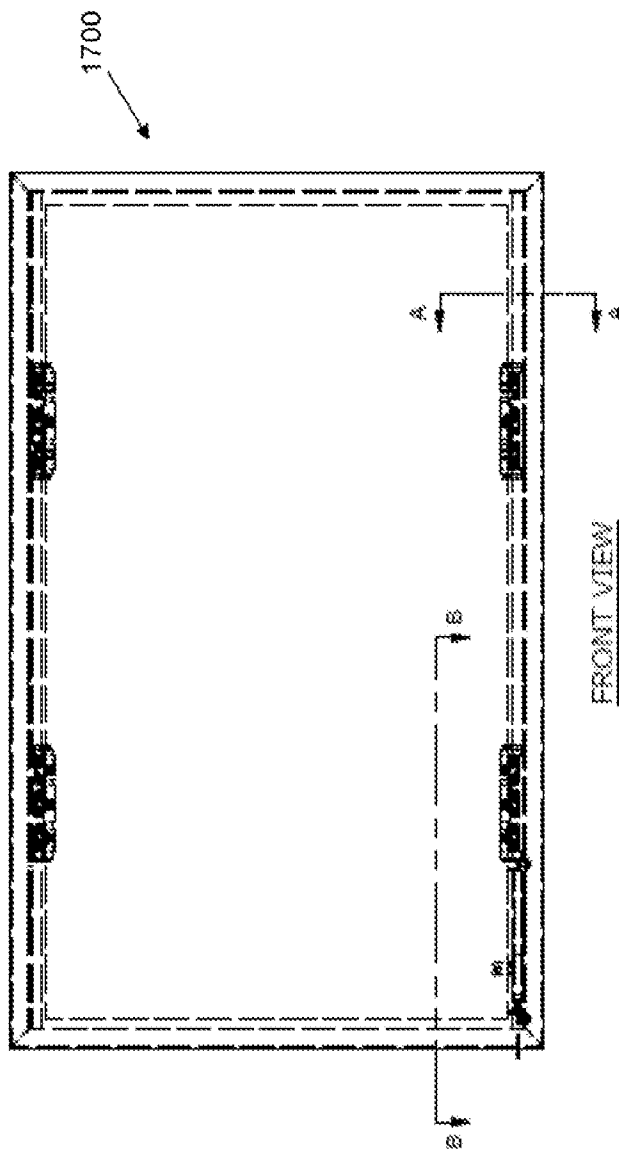
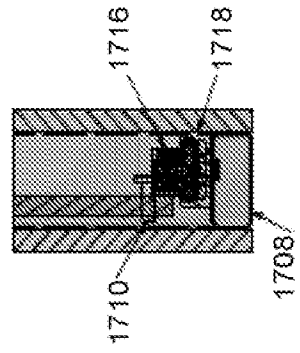

Fig. 17(a)

Fig. 17(c)



SECTION A-A

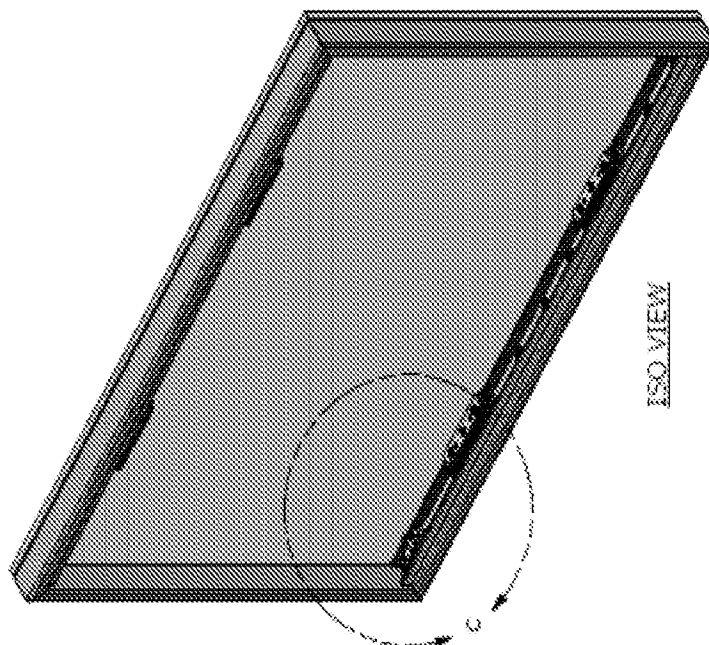
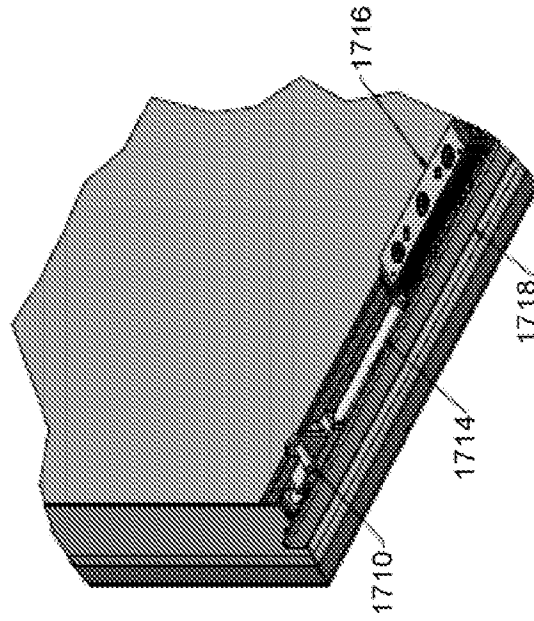

Fig. 17(b)



DETAIL C  
Fig. 17(e)

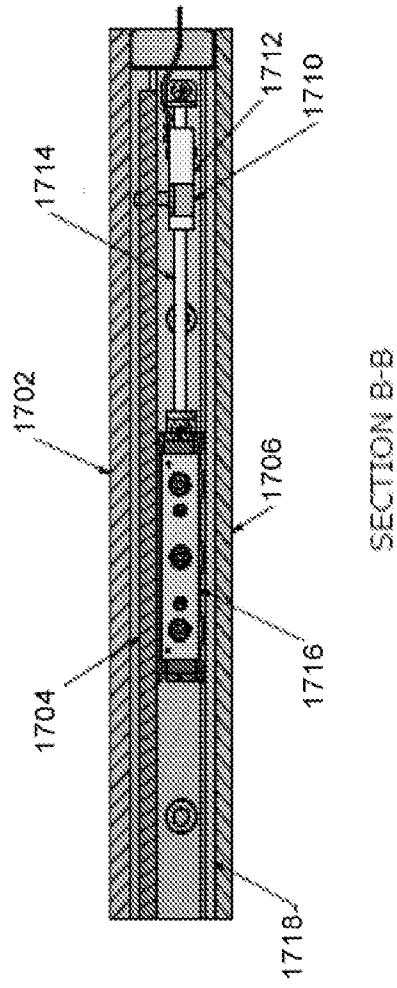

Fig. 17(d)

PATENT COOPERATION TREATY

PCT

INTERNATIONAL SEARCH REPORT

(PCT Article 18 and Rules 43 and 44)

Applicant's or agent's file reference JAR-3691-3026	<b>FOR FURTHER ACTION</b> see Form PCT/ISA/220 as well as, where applicable, item 5 below.	
International application No. PCT/US2013/040695	International filing date ( <i>day/month/year</i> ) 13 May 2013 (13-05-2013)	(Earliest) Priority Date ( <i>day/month/year</i> ) 22 May 2012 (22-05-2012)
Applicant  GUARDIAN INDUSTRIES CORP.		

This international search report has been prepared by this International Searching Authority and is transmitted to the applicant according to Article 18. A copy is being transmitted to the International Bureau.

This international search report consists of a total of 4 sheets.

It is also accompanied by a copy of each prior art document cited in this report.

1. **Basis of the report**

a. With regard to the **language**, the international search was carried out on the basis of:

- the international application in the language in which it was filed  
 a translation of the international application into \_\_\_\_\_, which is the language of a translation furnished for the purposes of international search (Rules 12.3(a) and 23.1 (b))

b.  This international search report has been established taking into account the **rectification of an obvious mistake** authorized by or notified to this Authority under Rule 91 (Rule 43.6**bis**(a)).

c.  With regard to any **nucleotide and/or amino acid sequence** disclosed in the international application, see Box No. I.

2.  **Certain claims were found unsearchable** (See Box No. II)

3.  **Unity of invention is lacking** (see Box No III)

4. With regard to the **title**,

- the text is approved as submitted by the applicant  
 the text has been established by this Authority to read as follows:

5. With regard to the **abstract**,

- the text is approved as submitted by the applicant  
 the text has been established, according to Rule 38.2, by this Authority as it appears in Box No. IV. The applicant may, within one month from the date of mailing of this international search report, submit comments to this Authority

6. With regard to the **drawings**,

- a. the figure of the **drawings** to be published with the abstract is Figure No. 11  
 as suggested by the applicant  
 as selected by this Authority, because the applicant failed to suggest a figure  
 as selected by this Authority, because this figure better characterizes the invention
- b.  none of the figures is to be published with the abstract

INTERNATIONAL SEARCH REPORT

International application No  
PCT/US2013/040695

A. CLASSIFICATION OF SUBJECT MATTER  
INV. H01L31/052 H01L31/048 E04D13/03  
ADD.  
According to International Patent Classification (IPC) or to both national classification and IPC

B. FIELDS SEARCHED  
Minimum documentation searched (classification system followed by classification symbols)  
H01L E04D

Documentation searched other than minimum documentation to the extent that such documents are included in the fields searched

Electronic data base consulted during the international search (name of data base and, where practicable, search terms used)  
EPO-Internal, WPI Data

C. DOCUMENTS CONSIDERED TO BE RELEVANT

Category*	Citation of document, with indication, where appropriate, of the relevant passages	Relevant to claim No.
X	WO 2011/139325 A2 (GUARDIAN INDUSTRIES [US]; KRASNOV ALEXEY [US]; DEN BOER WILLEM [US]) 10 November 2011 (2011-11-10) paragraph [0054] - paragraph [0056]; figure 1 paragraph [0032] paragraph [0042] paragraph [0009] paragraph [0039]	1-8, 11-21
X	WO 2009/137816 A2 (NEEROU TECHNOLOGIES INC [US]; KHAZENI KASRA [US]; AALAEI FARAJ [US]; G) 12 November 2009 (2009-11-12) paragraph [0063] - paragraph [0064] figures 11, 12, 17A, 17B, 18C, 18D, 19 paragraph [0072]	1,2, 4-10, 13-18, 20,21
	----- -/--	

Further documents are listed in the continuation of Box C.

See patent family annex.

\* Special categories of cited documents :

<p>"A" document defining the general state of the art which is not considered to be of particular relevance</p> <p>"E" earlier application or patent but published on or after the international filing date</p> <p>"L" document which may throw doubts on priority claim(s) or which is cited to establish the publication date of another citation or other special reason (as specified)</p> <p>"O" document referring to an oral disclosure, use, exhibition or other means</p> <p>"P" document published prior to the international filing date but later than the priority date claimed</p>	<p>"T" later document published after the international filing date or priority date and not in conflict with the application but cited to understand the principle or theory underlying the invention</p> <p>"X" document of particular relevance; the claimed invention cannot be considered novel or cannot be considered to involve an inventive step when the document is taken alone</p> <p>"Y" document of particular relevance; the claimed invention cannot be considered to involve an inventive step when the document is combined with one or more other such documents, such combination being obvious to a person skilled in the art</p> <p>"&amp;" document member of the same patent family</p>
---	---

Date of the actual completion of the international search <b>12 September 2013</b>	Date of mailing of the international search report <b>26/09/2013</b>
---	---

Name and mailing address of the ISA/ European Patent Office, P.B. 5818 Patentlaan 2 NL - 2280 HV Rijswijk Tel. (+31-70) 340-2040, Fax: (+31-70) 340-3016	Authorized officer <b>Chao, Oscar</b>
--	--

## INTERNATIONAL SEARCH REPORT

International application No  
PCT/US2013/040695

C(Continuation). DOCUMENTS CONSIDERED TO BE RELEVANT		
Category*	Citation of document, with indication, where appropriate, of the relevant passages	Relevant to claim No.
X	WO 2011/139324 A1 (GUARDIAN INDUSTRIES [US]; KRASNOV ALEXEY [US]; DEN BOER WILLEM [US]) 10 November 2011 (2011-11-10) paragraph [0054] paragraph [0044] - paragraph [0046] paragraph [0038] - paragraph [0039] -----	1-8, 11-21
X	WO 2011/048595 A2 (PYTHAGORAS SOLAR INC [US]; BARUCHI ITAY [IL]; BEN CHORIN MOSHE [IL]; F) 28 April 2011 (2011-04-28) abstract; figure 1 -----	1,14
A	WO 2010/010530 A2 (SOLECTA LTD [IL]; STEINBLATT SERGGE [IL]; PRITZKER ZEEV [IL]) 28 January 2010 (2010-01-28) abstract; figures 2A, 2B -----	7,9,10, 13,20
A	US 2012/037204 A1 (SUN TIEN-HSIANG [TW]) 16 February 2012 (2012-02-16) abstract; figures 2, 4b -----	7,9,10, 13,20

# INTERNATIONAL SEARCH REPORT

Information on patent family members

International application No PCT/US2013/040695
---

Patent document cited in search report	Publication date	Patent family member(s)	Publication date
WO 2011139325 A2	10-11-2011	EP 2564430 A2 US 2011259394 A1 WO 2011139325 A2	06-03-2013 27-10-2011 10-11-2011
WO 2009137816 A2	12-11-2009	US 2009277496 A1 US 2012103394 A1 WO 2009137816 A2	12-11-2009 03-05-2012 12-11-2009
WO 2011139324 A1	10-11-2011	EP 2563730 A1 US 2011263066 A1 WO 2011139324 A1	06-03-2013 27-10-2011 10-11-2011
WO 2011048595 A2	28-04-2011	CN 102742031 A EP 2491599 A2 JP 2013508582 A US 2012222722 A1 WO 2011048595 A2	17-10-2012 29-08-2012 07-03-2013 06-09-2012 28-04-2011
WO 2010010530 A2	28-01-2010	EP 2319085 A2 US 2011114180 A1 WO 2010010530 A2	11-05-2011 19-05-2011 28-01-2010
US 2012037204 A1	16-02-2012	CN 102376810 A TW 201207593 A US 2012037204 A1	14-03-2012 16-02-2012 16-02-2012