

(19) World Intellectual Property Organization
International Bureau



(43) International Publication Date
4 August 2011 (04.08.2011)

(10) International Publication Number
WO 2011/094121 A1

(51) International Patent Classification:

H01Q 5/00 (2006.01) *H01Q 21/28* (2006.01)
H01Q 13/02 (2006.01) *H01Q 25/02* (2006.01)
H01Q 19/08 (2006.01) *H01Q 19/17* (2006.01)

(21) International Application Number:

PCT/US2011/021989

(22) International Filing Date:

21 January 2011 (21.01.2011)

(25) Filing Language:

English

(26) Publication Language:

English

(30) Priority Data:

12/693,494 26 January 2010 (26.01.2010) US

(71) Applicant (for all designated States except US):

RAYTHEON COMPANY [US/US]; 870 Winter Street, Waltham, MA 02451-1449 (US).

(72) Inventors; and

(75) Inventors/Applicants (for US only): **MARTIN, Larry, C.** [US/US]; 2630 Locksley Pl., Los Angeles, California 90039 (US). **CHANG, Yueh-Chi** [US/US]; 8 Bridle Path Drive, Northborough, Massachusetts 01532 (US). **HAN-LIN, John, J.** [US/US]; 24 Strathmore Road, Worcester, Massachusetts 01610-2026 (US). **CALL, William, F.** [US/US]; 276 Central Street, Milford, Massachusetts 01757-3433 (US).

(74) Agents: **DURKEE, Paul, D.** et al.; Daly, Crowley, Moford & Durkee, LLP, Suite 301A, 354A Turnpike St., Canton, Massachusetts 02021 (US).

(81) Designated States (unless otherwise indicated, for every kind of national protection available):

AE, AG, AL, AM, AO, AT, AU, AZ, BA, BB, BG, BH, BR, BW, BY, BZ, CA, CH, CL, CN, CO, CR, CU, CZ, DE, DK, DM, DO, DZ, EC, EE, EG, ES, FI, GB, GD, GE, GH, GM, GT, HN, HR, HU, ID, IL, IN, IS, JP, KE, KG, KM, KN, KP, KR, KZ, LA, LC, LK, LR, LS, LT, LU, LY, MA, MD, ME, MG, MK, MN, MW, MX, MY, MZ, NA, NG, NI, NO, NZ, OM, PE, PG, PH, PL, PT, RO, RS, RU, SC, SD, SE, SG, SK, SL, SM, ST, SV, SY, TH, TJ, TM, TN, TR, TT, TZ, UA, UG, US, UZ, VC, VN, ZA, ZM, ZW.

(84) Designated States (unless otherwise indicated, for every kind of regional protection available):

ARIPO (BW, GH, GM, KE, LR, LS, MW, MZ, NA, SD, SL, SZ, TZ, UG, ZM, ZW), Eurasian (AM, AZ, BY, KG, KZ, MD, RU, TJ, TM), European (AL, AT, BE, BG, CH, CY, CZ, DE, DK, EE, ES, FI, FR, GB, GR, HR, HU, IE, IS, IT, LT, LU, LV, MC, MK, MT, NL, NO, PL, PT, RO, RS, SE, SI, SK, SM, TR), OAPI (BF, BJ, CF, CG, CI, CM, GA, GN, GQ, GW, ML, MR, NE, SN, TD, TG).

Declarations under Rule 4.17:

— as to applicant's entitlement to apply for and be granted a patent (Rule 4.17(ii))

[Continued on next page]

(54) Title: METHOD AND APPARATUS FOR TRI-BAND FEED WITH PSEUDO-MONOPULSE TRACKING

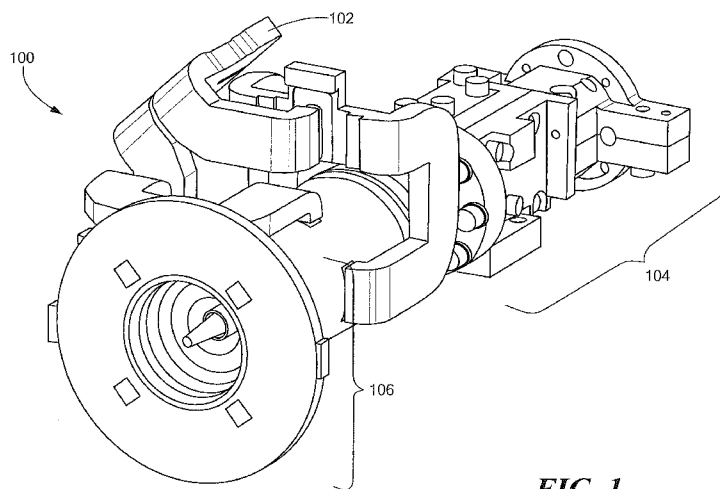

FIG. 1

(57) Abstract: Methods and apparatus for a feed assembly for a reflector antenna including an aperture common to low, mid, and high frequency bands, a polyrod design to launch signals in the mid and high frequency bands, a horn to launch signals in the low frequency band, a co-located phase center for launching signals in the low, mid, and high frequency bands, and a low-band monopulse array located on a surface about the aperture to track a satellite.

WO 2011/094121 A1

- *as to the applicant's entitlement to claim the priority of the earlier application (Rule 4.17(iii))* **Published:** — *with international search report (Art. 21(3))*

METHOD AND APPARATUS FOR TRI-BAND FEED
WITH PSEUDO-MONOPULSE TRACKING

BACKGROUND

5 [0001] Conventional SATCOM terminals utilize mechanical means for satellite tracking, such as gimbal scan or CONSCAN with a rotating subreflector. However, for COTM (Communication On The Move) applications, random perturbations such as those due to rapid vehicle movement over tough terrain will degrade the tracking accuracy to an unacceptable level.

10

[0002] Prior attempts for SATCOM electronic tracking include a dual-band tracking feed, using higher order modes to form azimuth and elevation difference patterns, a dual-band feed with electronic tracking capability using a TEM coaxial mode to receive a θ varying error signal, and a monopulse implemented using a single band horn with higher order
15 modes. In general such systems utilize large mode couplers and cannot be applied to a multi-band aperture. These systems offer pseudo-monopulse tracking only for single band or dual-band.

SUMMARY

20 [0003] The present invention provides methods and apparatus for a tri-band feed for a reflector antenna having pseudo-monopulse tracking capability. With this arrangement, a compact feed for satellite communication, especially for on the move communication systems, is provided. While exemplary embodiments of the invention are shown and described as having certain frequencies, components, applications and configurations, it is
25 understood that inventive embodiments are applicable to communication applications in general for which multi-band feeds are desirable.

[0004] In one aspect of the invention, a feed assembly for a reflector antenna comprises an aperture common to low, mid, and high frequency bands, a polyrod to launch signals in the
30 mid and high frequency bands while supporting the low band, a compact horn to launch signals in the low frequency band, a co-located phase center for launching signals in the low, mid, and high frequency bands, and a low-band monopulse array located on a surface about a perimeter of the aperture to track a satellite.

[0005] The feed assembly can further include one or more of the following features: respective beamwidths, e.g., 10-dB, for the low, mid, and high frequency bands are approximately equal, which are about 74° in an exemplary embodiment, the monopulse array includes a four patch antenna array, a waveguide network for the low frequency band is elongated to minimize blockage of the reflector antenna by the feed, a length of a polarizer for the mid and high frequency bands is reduced to minimize the blockage, a length of the feed is less than six inches, a diameter of the aperture is less than 2.5 inches, and the monopulse array is implemented in a single stripline layer.

10

[0006] In another aspect of the invention, a method comprises providing a feed assembly for a reflector antenna, comprising: providing an aperture common to low, mid, and high frequency bands, providing a polyrod to launch signals in the mid and high frequency bands while supporting the low band, providing a compact horn to launch signals in the low frequency band, providing a co-located phase center for launching signals in the low, mid, and high frequency bands, and providing a low-band monopulse array located on a surface about a perimeter of the aperture to track a satellite.

15

[0007] The method can further include one or more of the following features: respective beamwidths, e.g., 10-dB, for the low, mid, and high frequency bands are approximately equal, which are about 74° in an exemplary embodiment, providing the monopulse array to include a four patch antenna array, elongating a waveguide network for the low frequency band to minimize blockage of the reflector antenna by the feed, reducing a length of a polarizer for the mid and high frequency bands to minimize the blockage, a length of the feed is less than six inches, a diameter of the aperture is less than 2.5 inches, and implementing the monopulse array in a single stripline layer.

20
25

BRIEF DESCRIPTION OF THE DRAWINGS

[0008] The foregoing features of this invention, as well as the invention itself, may be more fully understood from the following description of the drawings in which:

5

[0009] FIG. 1 is an isometric view of a tri-band feed in accordance with exemplary embodiments of the invention;

[0010] FIG. 2 is a cross-sectional view of the tri-band feed of FIG. 1;

10

[0011] FIG. 3 is an isometric view of the polyrod shown in FIG. 2;

[0012] FIGs. 4A-4C show respective isometric, side, and front views of a low-band waveguide network for a tri-band feed;

15

[0013] FIG. 5 is a schematic representation of a prior art turnstile junction;

[0014] FIG. 6 is a schematic representation of a prior art dual-band orthomode transducer;

20

[0015] FIG. 7 is a schematic representation of the dual-band (mid and high bands) polarizer shown in FIG. 2;

[0016] FIG. 8 is an isometric view of the dual-band (mid and high bands) diplexer and orthomode transducer of the tri-band feed shown in FIG. 2;

25

[0017] FIG. 9 shows calculated feed patterns at middle frequencies of three bands comparing with an ideal theoretical feed pattern for an example tri-band feed;

[0018] FIG. 10 is a RF block diagram of a pseudo-monopulse feed system;

30

[0019] FIG. 11A is schematic representation of a branch line comparator;

[0020] FIG. 11B is a schematic representation of a stripline implementation of the branch line comparator of FIG. 11A for a multi-band feed;

[0021] FIG. 12 is a schematic representation of a branch line coupler;

5

[0022] FIG. 13 is an exploded view of an aperture coupled patch radiator;

[0023] FIG. 14 is a schematic representation of a single fed patch with circular polarization;

10 [0024] FIGs. 15A and 15B are schematic representations of branch line comparator operation for delta azimuth and delta elevation; and

[0025] FIG. 16 is a schematic representation of a tri-band feed and reflector antenna.

15 DETAILED DESCRIPTION

[0026] Exemplary embodiments of the invention provide a tri-band feed to achieve electronic tracking for satellite communication (SATCOM). It is understood that electronic tracking offers significant advantages over mechanical tracking by increasing the scanning speed of the antenna beam and allowing multiple scans to be performed during a single
20 frequency sync hop. Signal variation, particularly in a COTM (communications on the move) application, can vary over the relatively long scan interval of a mechanical tracking system leading to large tracking errors and increased noise into the tracking loop. By using electronic scanning the scan interval is reduced by an order of magnitude and the effect of signal fading and random disturbances can be greatly reduced.

25

[0027] Exemplary embodiments of the invention provide a compact tri-band feed useful for SATCOM (satellite communication) antennas, for example, that achieves high antenna efficiencies and low sidelobes. In exemplary embodiments, the feed includes a center conductor with a polyrod to launch mid-band and high-band energy into free space. The
30 internal end of the polyrod tapers to a point while the diameter of the center conductor surrounding it gradually increases up to the internal tip of the polyrod in order to support the dominant mode of the mid-band frequency and to provide good impedance match. A compact horn with a taper section and a corrugation launches the low-band and helps shape

the patterns of the mid-band and high-band. The tri-band feed also includes co-located phase centers. In one embodiment, the tri-band feed has approximately equal 10-dB beamwidths for the three bands.

5 [0028] In exemplary embodiments, the monopulse feed provides radiating elements for a reflector antenna with multiple beams (Σ , ΔAZ , and ΔEL) in the downlink band and a single beam in the uplink band. A monopulse network provides monopulse tracking capability.

[0029] To add monopulse tracking capability to a tri-band feed with minimal impact on the
10 antenna efficiencies and sidelobes, a four-patch array fed by stripline is provided. The patch radiators and beamforming network are compact and low loss. The beamforming network is traced around the feed using an innovative offset stripline with a low dielectric foam layer to separate the ground plane and drive the field to the higher dielectric layer. The trace layer employs low loss material with a slotted cover to couple to four circularly polarized
15 patches.

[0030] FIG. 1 shows an exemplary tri-band feed 100 with pseudo-monopulse tracking in accordance with exemplary embodiments. In the illustrative embodiment, the low, mid, and high bands that make up the tri-bands of the feed include K (20.2-21.2 GHz), Ka (30-31
20 GHz), and Q (43.5-45.5 GHz) bands. The feed 100 includes a K-band circular polarizer 102 and a Q, Ka band polarizer 104. The face of the aperture includes a monopulse array 106.

[0031] As shown in FIG. 2, the feed 100 includes a center conductor with a polyrod 200 to launch mid-band (Ka) and high-band (Q) energy into the free space and a polarizing vane
25 202 to convert linear polarization (LP) into circular polarization (CP). As shown in FIG. 3, the internal end 204 of the polyrod tapers to a point while the diameter of the center conductor surrounding it gradually increases at the same time up to the internal tip of the polyrod. The dielectric loading of the center conductor reduces the diameter size needed to support the dominant mode of the mid-band (Ka). The reduction of the center conductor
30 diameter makes the low-band coaxial waveguide and its associated waveguide network possible otherwise, impedance matching at the low-band would be almost impossible. The taper section on the polyrod and waveguide is to ensure a gradual impedance change to

avoid a mismatch for both mid and high bands. It is understood that dielectric loading and taper for impedance matching to meet the needs of a particular application is well within the ordinary skill in the art.

5 [0032] FIGs. 4A-C show a compact horn 210 with a taper section 212 and a single corrugation 214 to launch the low-band (K) energy and also shape the patterns of the mid-band and high-band. A low-band waveguide network 216 includes a coaxial turnstile junction 218, a series of waveguide bends 220, two 180° hybrids 222 and a 90° hybrid 223 to provide a compact, minimized cross section with optimized RF performance. The
10 coaxial turnstile junction 218 allows the low-band energy to be coupled out to four symmetric rectangular waveguide channels with low loss. The symmetry of the structure ensures that generation of higher order modes will be minimal. The two 180° hybrids 222 are used to combine vertical and horizontal channels, and the 90° hybrid 223 converts these two combined signals into RHCP (Right Hand Circular Polarization) and LHCP (Left Hand
15 Circular Polarization) signals. Note that the vertical pairs are bent toward feed horn and the horizontal pairs are bent away before being combined to avoid physical interference.

[0033] FIG. 5 shows an exemplary turnstile junction 10 that can form a part of an orthomode transducer (OMT). The turnstile junction 10 includes four rectangular
20 waveguide ports in a common plane placed symmetrically around and orthogonal to a longitudinal axis of a circular or square main waveguide. FIG. 6 shows an exemplary OMT with a turnstile junction. Exemplary orthomode transducers and turnstiles are shown and described in U.S. Patent No. 7,397,323, which is incorporated herein by reference.

25 [0034] FIG. 7 shows for the mid-band and high-band the common dielectric vane polarizer 202 of FIG. 2 used in conjunction with a squeezed waveguide section to achieve low axial ratio performance for both mid and high bands. As is known in the art, a squeezed waveguide, using a series of capacitive posts or flat bottom along the floor of the waveguide, provides needed phase differential near the low end of the band to achieve 90°
30 phase shift. Along with a dielectric vane, the squeezed waveguide provides low axial ratio over a wide range of frequency band.

[0035] FIG. 8 shows the back of the feed including a 4-port diplexer to separate two mid-band ports and the high-band port. The diplexer has a common circular (or square) port 310, two orthogonal rectangular mid-band ports 320, and one rectangular high-band port 330. As is known in the art, a waveguide diplexer is a device for combining/separating multi-band and multi-port signals to provide either band or polarization discrimination.

[0036] In an exemplary embodiment, the tri-band feed has co-located phase centers and approximately equal 10-dB beamwidths for all three bands, as shown in FIG. 9. In the illustrative embodiment, the K-band pattern is for 20.7 GHz, the Ka band is for 30.5 GHz, and the Q band is for 44.5 GHz. Co-location of the feed phase centers for all three bands achieves high phase efficiencies of the antenna for all three bands. Otherwise, a compromised phase center has to be used to place the feed in the tri-band reflector antenna, which will degrade the phase efficiencies depending on the amount of compromise. Likewise, approximately equal 10-dB beamwidths achieve optimized aperture efficiencies of the antenna. Otherwise, illumination efficiencies and spillover losses of the desired three bands have to be compromised.

[0037] In an exemplary embodiment, a monopulse four-patch array is provided on the feed aperture. As is known in the art, monopulse antennas can be designed in a variety of configurations. Tradeoffs in feed design are made among optimal sum and difference signals, low sidelobes, multi-band operation, and circular polarization. One type of monopulse feed implementation includes single horn and four horns. A second type is to use single horn with non-symmetrical higher-order modes for the difference signals. The sum signal is received through the dominant waveguide mode. Sum and difference signals are isolated using mode coupling devices eliminating the need for a monopulse comparator.

[0038] In one embodiment shown in FIG. 10, the monopulse patch array includes first and second magic tees 402a,b and a pair of phase reversers (180° 1-bit phase shifters) 404a,b. A horn 406 feeds the first magic 402a the ΔAZ and ΔEL signals and provides the SUM (Σ) signal to a coupler 408, which is coupled to the second magic tee 402b via a phase shim 410.

[0039] By switching the phase of each phase shifter, the antenna beam is sequentially rotated to each quadrant as follows:

$$\phi_1 = 0^\circ \quad \phi_2 = 0^\circ, \text{ DEL} = +\Delta\text{EL}$$

$$\phi_1 = 180^\circ \quad \phi_2 = 180^\circ, \text{ DEL} = -\Delta\text{EL}$$

5 $\phi_1 = 0^\circ \quad \phi_2 = 180^\circ, \text{ DEL} = +\Delta\text{AZ}$

$$\phi_1 = 180^\circ \quad \phi_2 = 0^\circ, \text{ DEL} = -\Delta\text{AZ}$$

[0040] The phase reversers 404 and magic tees 402 can be implemented using waveguide in a manner well known to one of ordinary skill in the art. The ΔEL signal and ΔAZ signal are input to the delta and sum port of the first magic tee 402a. The signals then combine and are input into the first and second voltage controlled phase reversers 404a,b. The shifted signals then enter the second magic tee 402b where the unselected portion is loaded and the phase-selected signal is coupled to the received communication (sum) signal. The phase shim 410 corrects path length differences between the sum and delta arms.

15

[0041] It is understood that the coupler 408 plays a significant role in determining the downlink loss and tracking accuracy. A small coupling coefficient leads to lower downlink loss but less tracking accuracy, while a large coupling coefficient has the opposite effect. In one embodiment, a 13 dB coupler provides a good balance between downlink loss and tracking accuracy.

20

[0042] In an exemplary embodiment shown in FIG. 11A, the monopulse includes a plurality of branch line couplers 500 and $\frac{1}{4} \lambda$ phase shifters 502 to feed patch radiators 504 and form the delta patterns. In one embodiment, this is implemented on a single trace layer to allow greater flexibility in feeding the patch radiators 504 for eliminating the need for multilayer vias and probes.

25

[0043] In one embodiment, the patches 504 are placed at the diagonals of the sum horn to reduce the element spacing and reduce grating lobes in the azimuth and elevation planes.

30

FIG. 11B shows a stripline representation of the comparator.

[0044] In an exemplary embodiment, the branch line comparator is formed from entirely of passive microwave components. Table 1 lists the layer stack-up used to construct an illustrative comparator. Offset stripline was used to obtain ground plane shielding while still having the ability to use aperture coupled patches. A rigid foam, such as Rohacell PMI foam, with a dielectric close to air ($\epsilon_r = 1.04$) was used as a spacer between the trace and ground plane. The foam spacer greatly reduced the loss allowing a low loss, low dielectric substrate, such as Rogers Corporation RT 5880 high frequency laminate, to be used as the trace layer, because the trace has a higher dielectric constant than the foam the majority of the field propagates in the low dielectric layer.

10 Table 1 Monopulse array and comparator layer stack up

Layer		ϵ_r	Loss Tan	Thickness (mils)
8	Patch			0.675
7	Rogers RT 5880	2.22	0.0009	31
6	Cover			0.675
5	Rogers RT 5880	2.22	0.0009	10
4	Trace			0.675
3	ROHACELL Foam	1.04	0.0106	125
2	3M VSB Adhesive	2.00	0.0400	15
1	Ground			0.675

[0045] In one embodiment, the monopulse comparator is traced on inhomogeneous offset stripline. Because the majority of the field propagates on the low loss dielectric substrate it is more similar to a quasi-TEM microstrip line with a substrate height of 10 mils, thus equation 1 was used for a first order approximation of the lines characteristic impedance. HFSS (High Frequency Structural Simulator - a finite element method solver for electromagnetic structures from Ansoft Corporation) was used to calculate the effective dielectric constant and wavelength in the material at 1.92 and 1.06 cm respectively. A line width of 31 mils resulted in a characteristic impedance of 50 Ohms.

$$Z_o = \begin{cases} \frac{60}{\sqrt{\epsilon_s}} \ln \left(\frac{8d}{W} + \frac{W}{4d} \right) & \text{for } \frac{w}{d} \leq 1 \\ \frac{120\pi}{\sqrt{\epsilon_s} \left[\frac{W}{d} + 1.393 + (0.667 \ln(W/d + 1.444)) \right]} & \text{for } \frac{w}{d} \geq 1 \end{cases} \quad \text{Eq. 1}$$

[0046] In one embodiment, the branch line coupler is a 3 dB directional coupler with a 90° phase difference between the output ports. As shown in FIG. 12, the coupler can be constructed using quarter wavelength lines with impedances of Z_0 and $\frac{Z_0}{\sqrt{2}}$, where Z_0 is the characteristic impedance of 50 Ohms. In operation of the branch line coupler power entering port 1 is evenly split with a 90° phase difference between ports 2 and 3. Port 4 is isolated and receives no power.

[0047] In an exemplary embodiment, the monopulse array includes four patch radiators tuned at low band to receive and form delta azimuth and elevation signals. Aperture coupled patches provide more design flexibility and lower manufacturing tolerances over a traditional probe fed patch. Using aperture-coupled patches enables independent optimization of the trace/feed layer, elimination of feed radiation, and increased bandwidth.

[0048] FIG. 13 shows an exemplary aperture-coupled patch including a minimum of three layers; the first layer is the trace substrate, followed by a slotted cover, and finally the patch substrate. Generally the coupling aperture is placed in the center of the patch to maximize coupling and reduce cross-polarization.

[0049] The general form of the aperture-coupled patch was adapted for circular polarization and stripline feeding. Crossed rectangular slots were used to excite both the TM_{100} and the TM_{010} mode. A perturbation Δ was introduced along the patch sides as illustrated in FIG. 14 to create a phase difference of 90° between the two modes. The combination of the two modes produces a dual tuned response. Stripline feeding was accomplished by using an offset stripline stack-up as listed in Table 1 above. The stripline was traced on low loss dielectric, e.g., Rogers 5880, and separated from the ground plane by a 125-mil layer of foam. By using foam with a lower dielectric constant than the low dielectric, e.g., Rogers 5880, the offset geometry allowed the field to propagate in the higher dielectric and couple to the patches.

[0050] FIGs. 15A and 15B show the branch line comparator using $\frac{1}{4} \lambda$ phase shifts and branch line couplers to shape the received field to form delta azimuth and delta elevation signals. The four patch radiators are labeled A to D. The delta azimuth (FIG. 15A) fields

show patches A and B 180° out of phase and patches C and D 180° out of phase. This phase difference creates a null in the vertical plane producing a total received field of A-B-C+D at the delta azimuth port. Similarly the delta elevation (FIG. 15B) fields show patches A and C 180° out of phase and patches A and D 180° out of phase. This phase difference creates a null in the horizontal plane producing a total received field of A+B-C-D at the delta elevation port. It is also evident that the delta azimuth and elevation ports are isolated.

[0051] Since a reflector antenna will be used, as shown in FIG. 16, blockage should be minimized. In an exemplary embodiment, the low band network was elongated and reduced in size, TEM error ports are removed, and the length of the dual band (mid and high) polarizer was reduced to facilitate use of the inventive tri-band feed FE with low profile reflector antennas in COTM applications. Without these design features, the low-band network will block some of the energy between the subreflector SR and main reflector MR and could cause significant blockage loss for the antenna.

[0052] In an exemplary embodiment, a tri-band feed is less than about six inches long with an aperture diameter less than about 2.5 inches to minimize blockage. As discussed above, the aperture is common to Q, Ka, K band communication with co-located phase centers with approximately same 10-dB beamwidths for the three bands.

[0053] It is understood that while the tri-band feed with monopulse tracking is shown and described in exemplary embodiments as including the K (20.2-21.2 GHz), Ka (30-31 GHz), and Q (43.5-45.5 GHz), it is understood that other embodiments can include different frequencies to meet the needs of a particular application without departing from the scope of the present invention.

[0054] Exemplary embodiments of the present invention provide a tri-band compact feed design that provides superior performance for the three frequency bands and pseudo-monopulse tracking capability. A novel compact and low loss patch array with beamforming network is implemented on a single stripline layer. In addition, the tri-band feed utilizes aperture coupled patches with the inherent radiation isolation of stripline.

Further, the inventive tri-band feed provides a significant increase in tracking performance with little impact on antenna efficiency and sidelobes.

[0055] Having described exemplary embodiments of the invention, it will now become
5 apparent to one of ordinary skill in the art that other embodiments incorporating their
concepts may also be used. The embodiments contained herein should not be limited to
disclosed embodiments but rather should be limited only by the spirit and scope of the
appended claims. All publications and references cited herein are expressly incorporated
herein by reference in their entirety.

10

What is claimed is:

12

13

- 1 1. A feed assembly for a reflector antenna, comprising:
2 an aperture common to low, mid, and high frequency bands;
3 a polyrod to launch signals in the mid and high frequency bands while supporting
4 the low band;
5 a compact horn to launch signals in the low frequency band;
6 a co-located phase center for launching signals in the low, mid, and high frequency
7 bands; and
8 a low-band monopulse array located on a surface about a perimeter of the aperture to
9 track a satellite.
10
- 11 2. The feed assembly according to claim 1, wherein respective beamwidths for the low,
12 mid, and high frequency bands is approximately equal.
13
- 14 3. The feed assembly according to claim 2, wherein the respective beamwidths are about
15 10 dB.
16
- 17 4. The feed assembly according to claim 1, wherein the monopulse array includes a four
18 patch antenna array.
19
- 20 5. The feed assembly according to claim 1, wherein a waveguide network for the low
21 frequency band is elongated to minimize blockage of the reflector antenna.
22
- 23 6. The feed assembly according to claim 1, wherein a length of a polarizer for the mid and
24 high frequency bands is reduced to minimize blockage of the reflector antenna.
25
- 26 7. The feed assembly according to claim 1, wherein a length of the feed is less than six
27 inches.
28
- 29 8. The feed assembly according to claim 1, wherein a diameter of the aperture is less than
30 2.5 inches.
31

1 9. The feed assembly according to claim 1, wherein the monopulse array is implemented in
2 a single stripline layer.

3
4 10. The feed assembly according to claim 1, wherein the monopulse array provides sum,
5 delta azimuth, and delta elevation beams in a downlink band and a single beam in an uplink
6 band.

7
8 11. The feed assembly according to claim 1, further including a turnstile junction coupled
9 to the horn for coupling low-band energy to four symmetric waveguide channels.

10
11 12. A method, comprising:

12 receiving and transmitting signals using a feed assembly for a reflector antenna
13 having an aperture common to low, mid, and high frequency bands;

14 employing a polyrod to launch signals in the mid and high frequency bands while
15 supporting the low band and employing a compact horn to launch signals in the low
16 frequency band, wherein a phase center for launching signals in the low, mid, and high
17 frequency bands is co-located; and

18 employing a low-band monopulse array located on a surface about a perimeter of the
19 aperture to track a satellite.

20
21 13. The method according to claim 12, further including employing respective beamwidths
22 for the low, mid, and high frequency bands that are approximately equal.

23
24 14. The method according to claim 13, wherein the respective beamwidths are about 10
25 dB.

26
27 15. The method according to claim 13, wherein the monopulse array includes a four patch
28 antenna array.

29
30 16. The method according to claim 13, further including elongating a waveguide network
31 for the low frequency band to minimize blockage of the reflector antenna.

1 17. The method according to claim 13, further including reducing a length of a polarizer
2 for the mid and high frequency bands to minimize blockage of the reflector antenna.

3

4 18. The method according to claim 13, wherein a length of the feed is less than six inches.

5

6 19. The method according to claim 13, wherein a diameter of the aperture is less than 2.5
7 inches.

8

9 20. The method according to claim 13, further including implementing the monopulse
10 array in a single stripline layer.

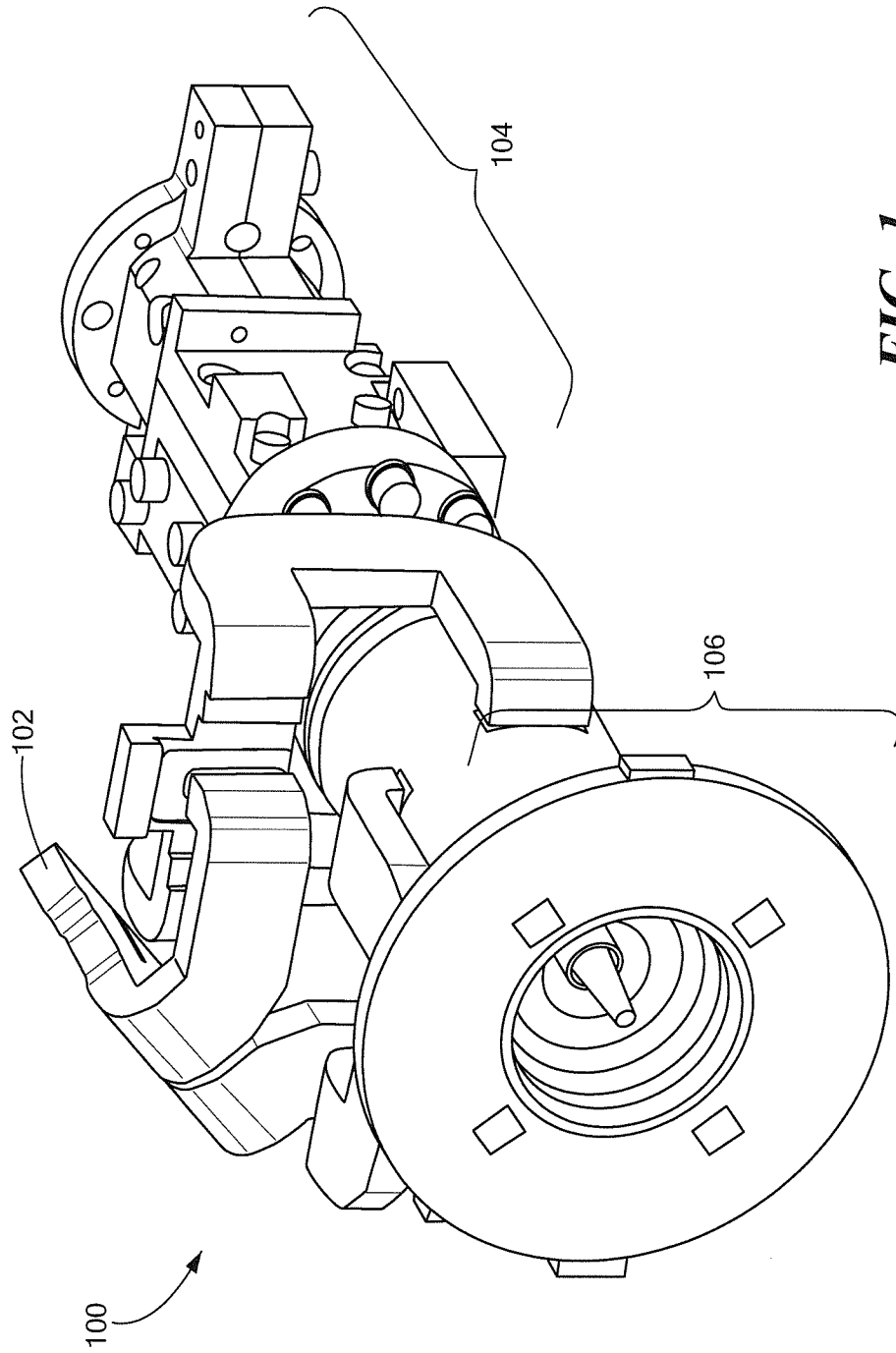

FIG. 1

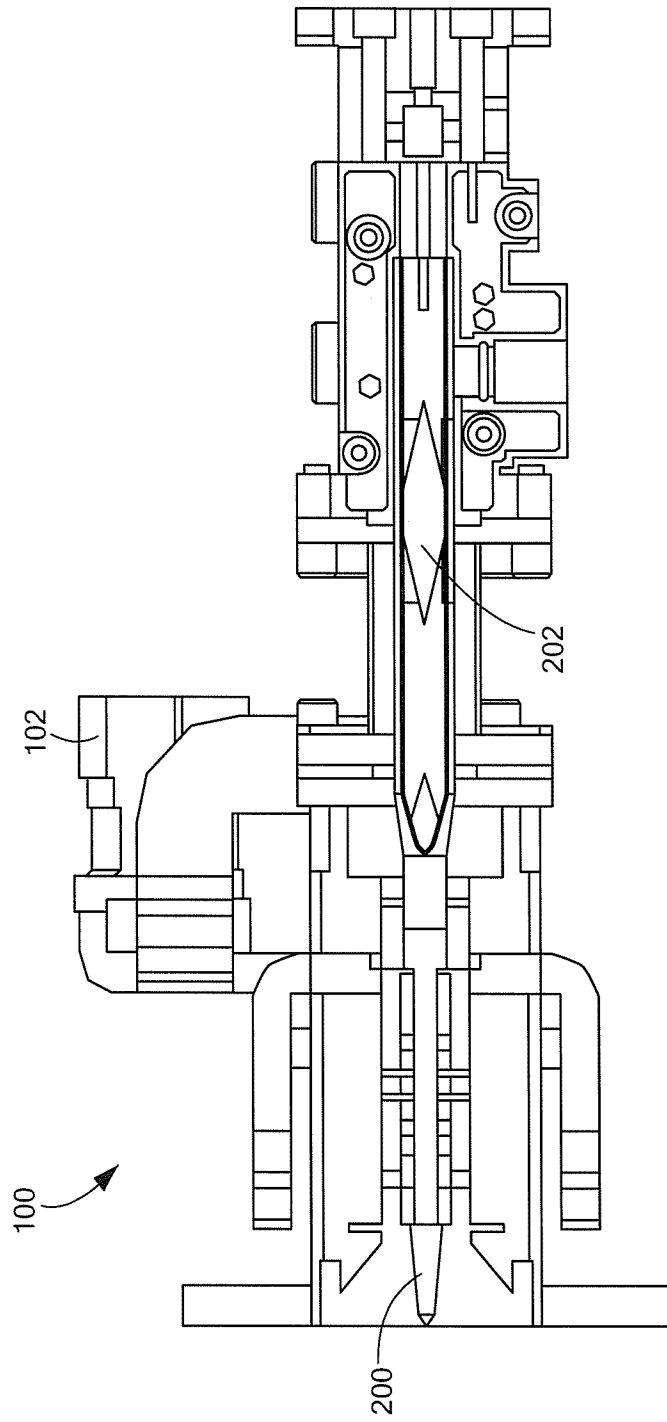

FIG. 2

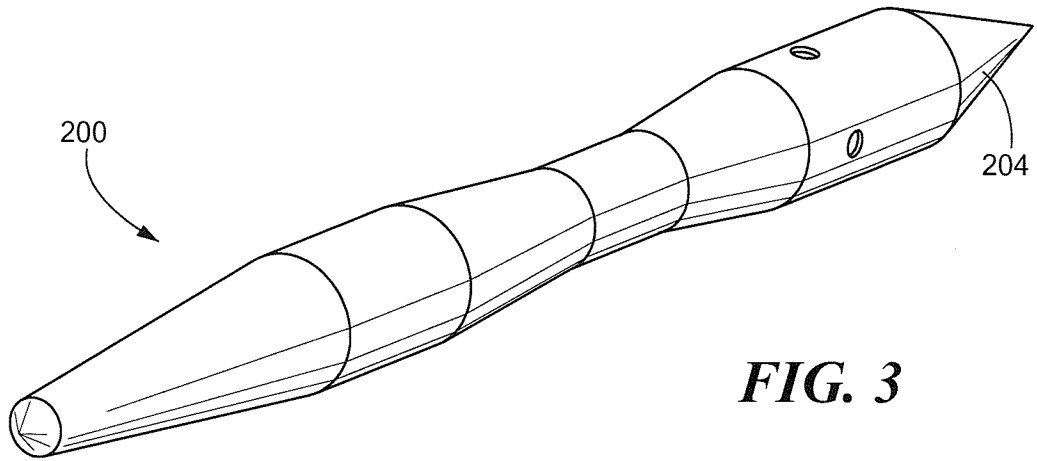

FIG. 3

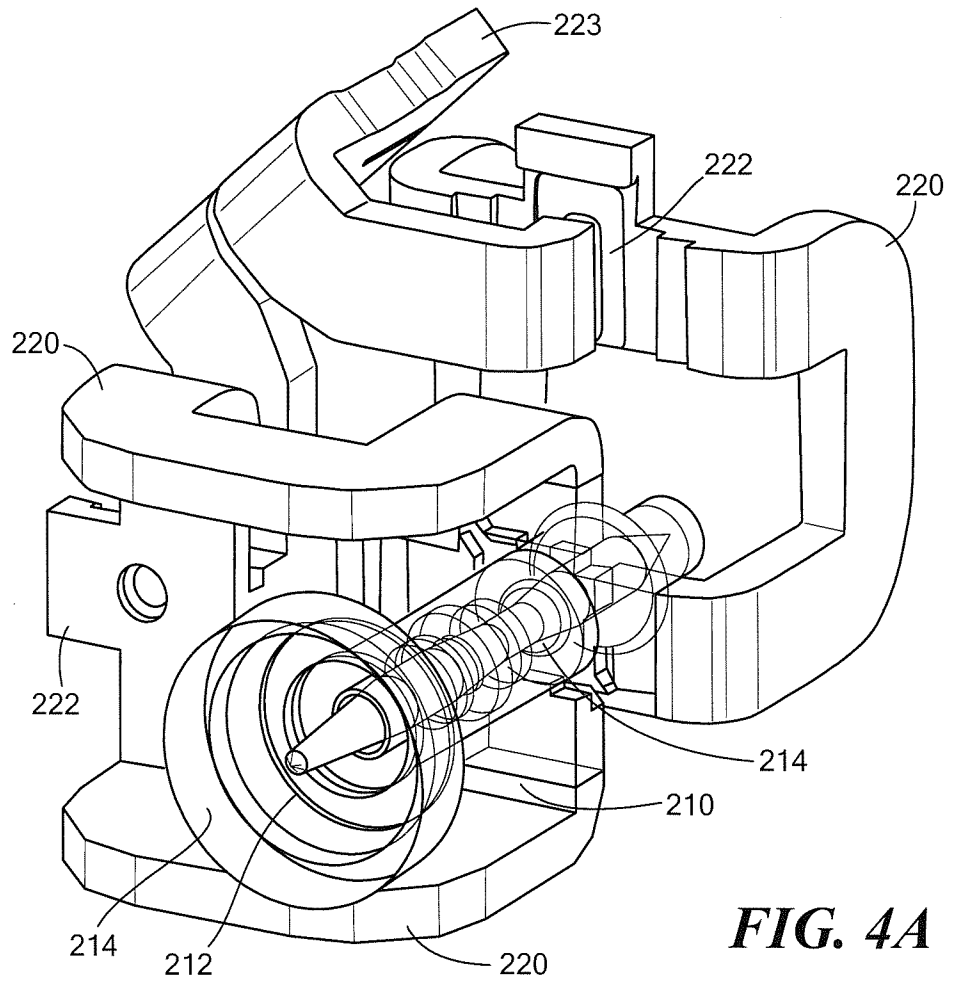

FIG. 4A

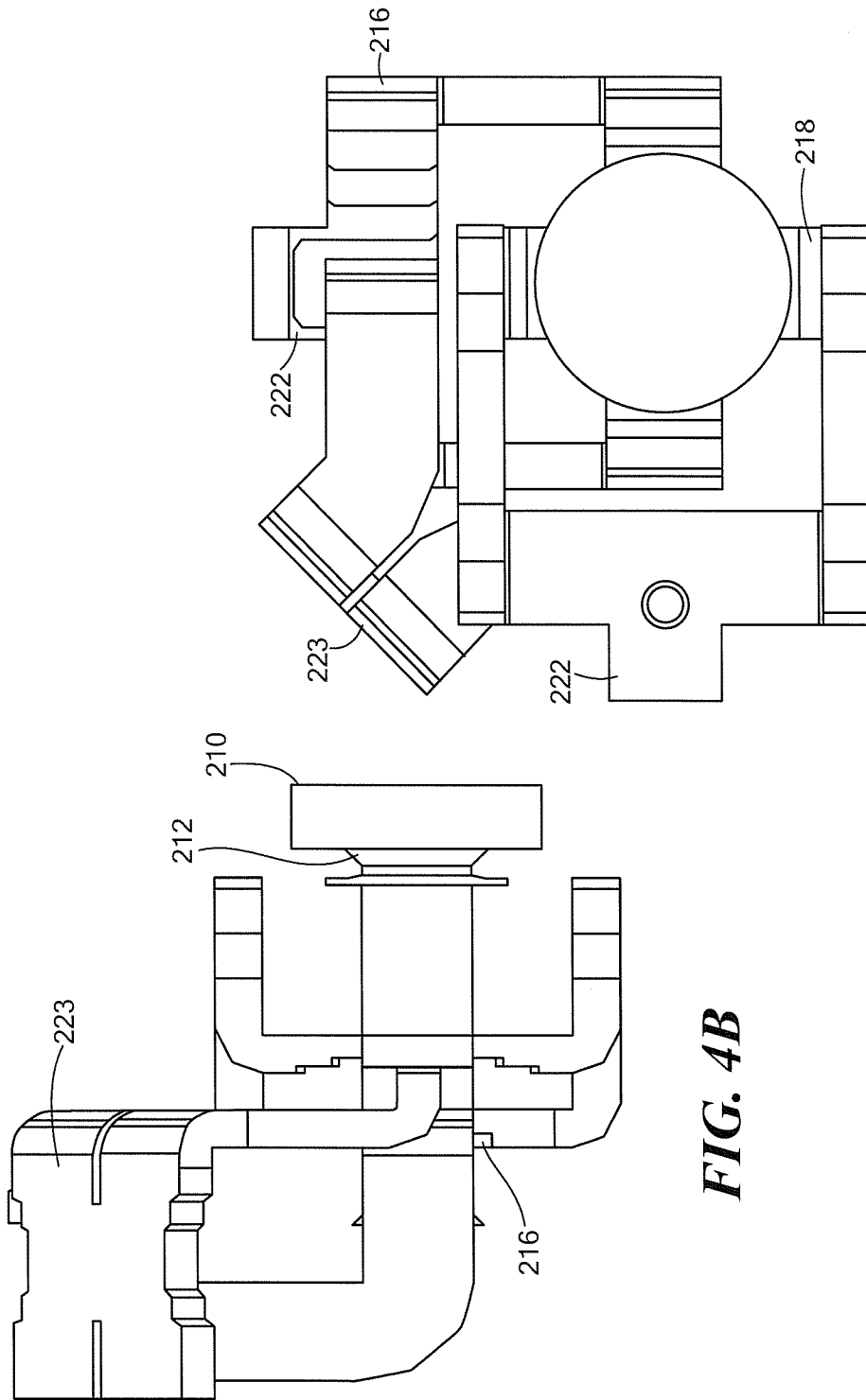

FIG. 4B

FIG. 4C

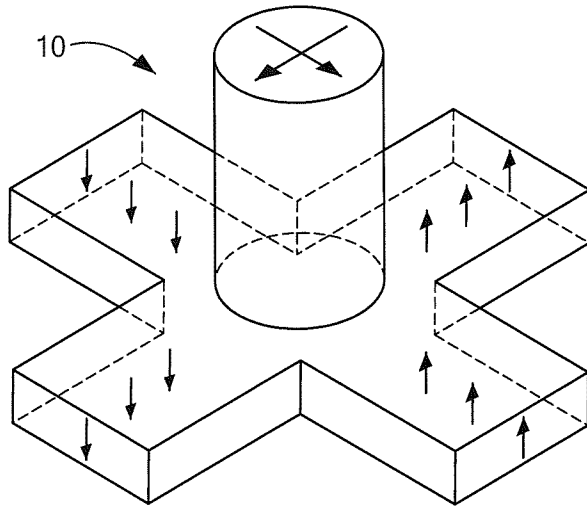

FIG. 5
PRIOR ART

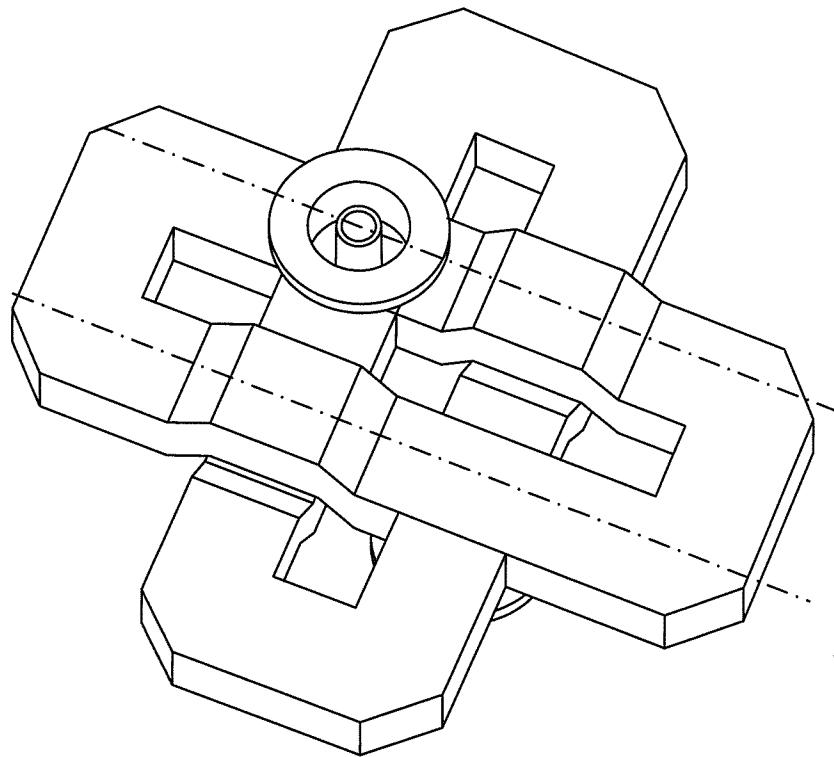

FIG. 6
PRIOR ART

6/13

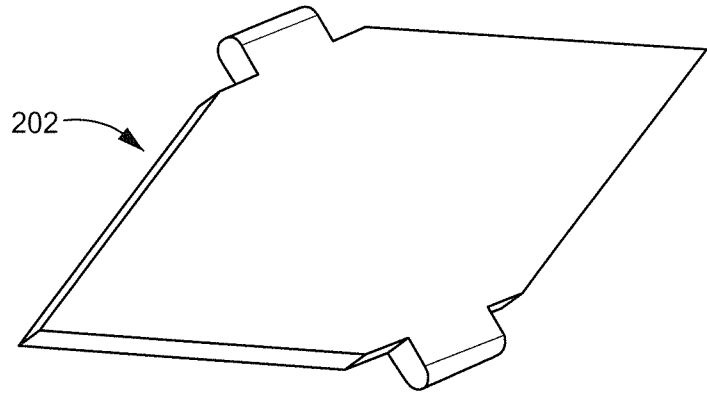

FIG. 7

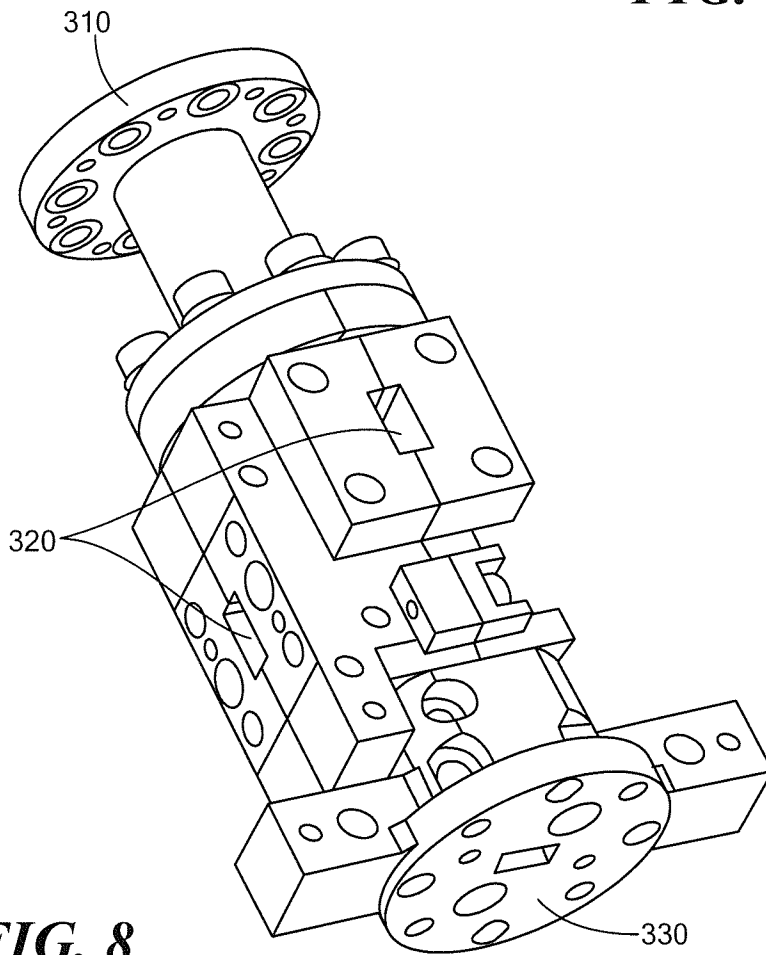

FIG. 8

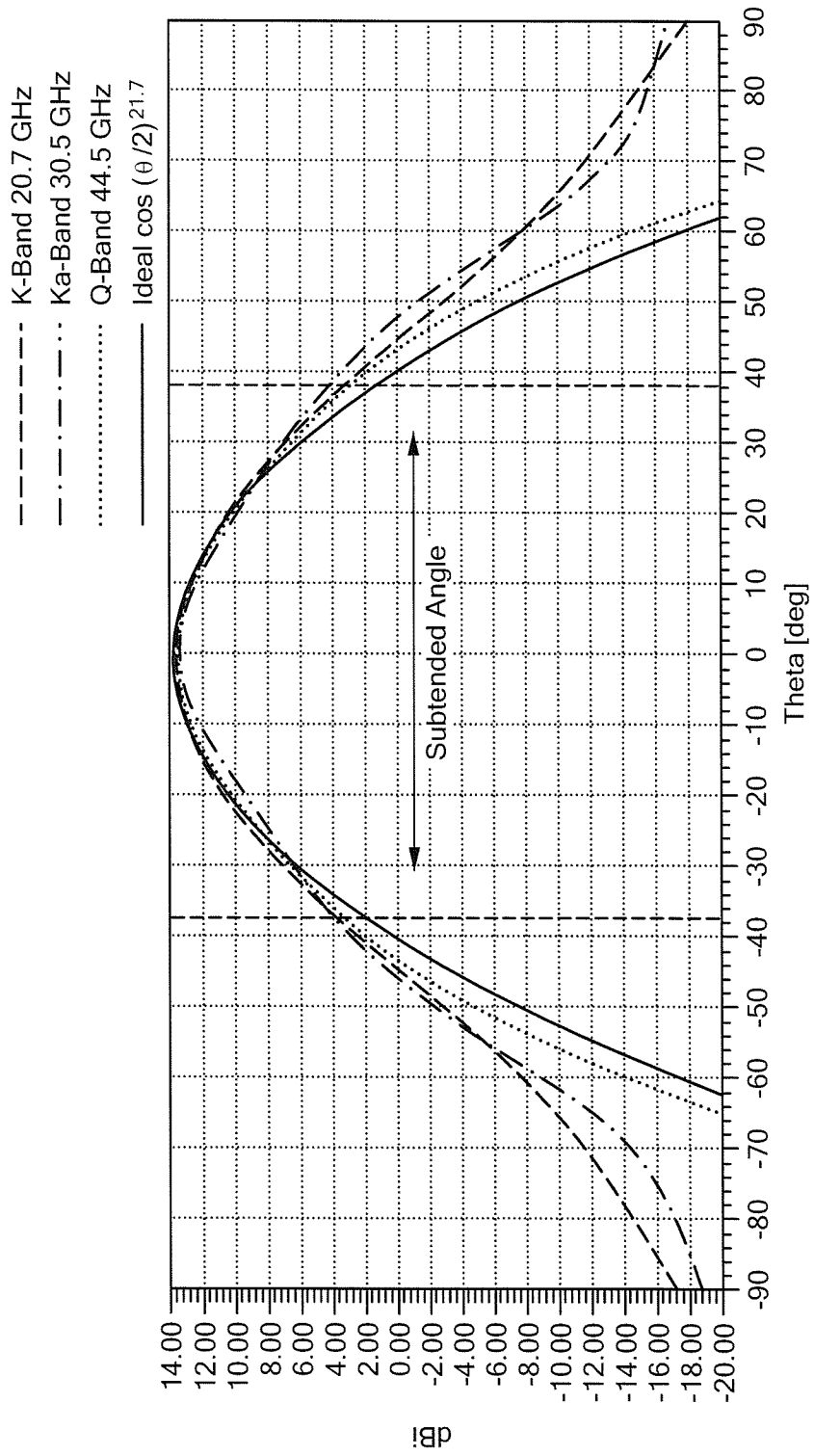

FIG. 9

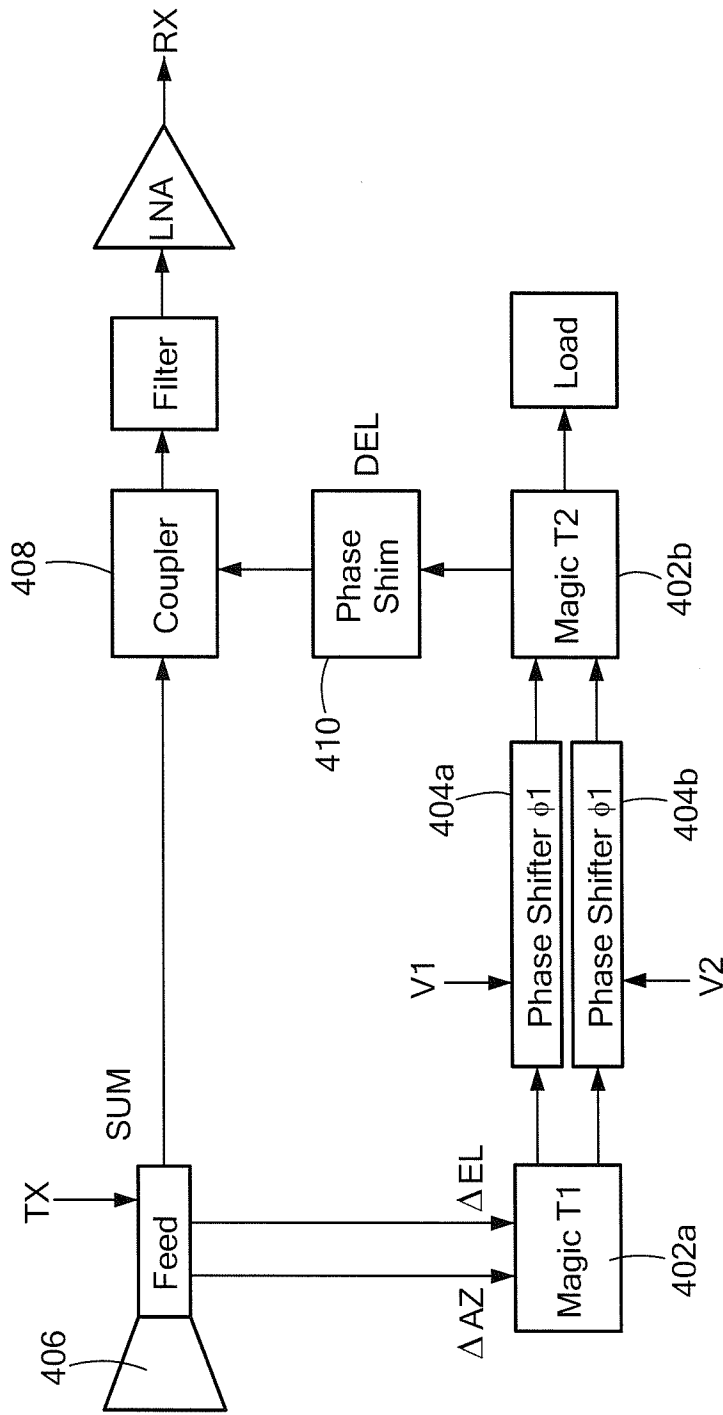

FIG. 10

9/13

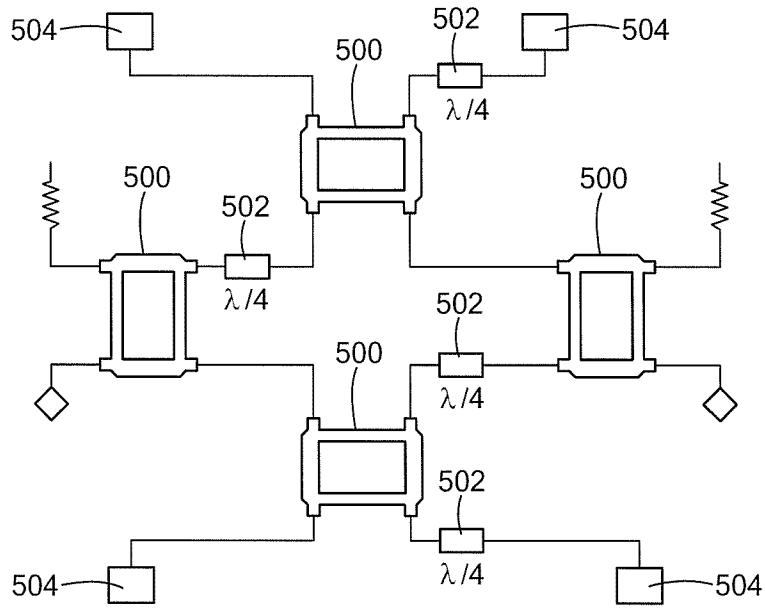

FIG. 11A

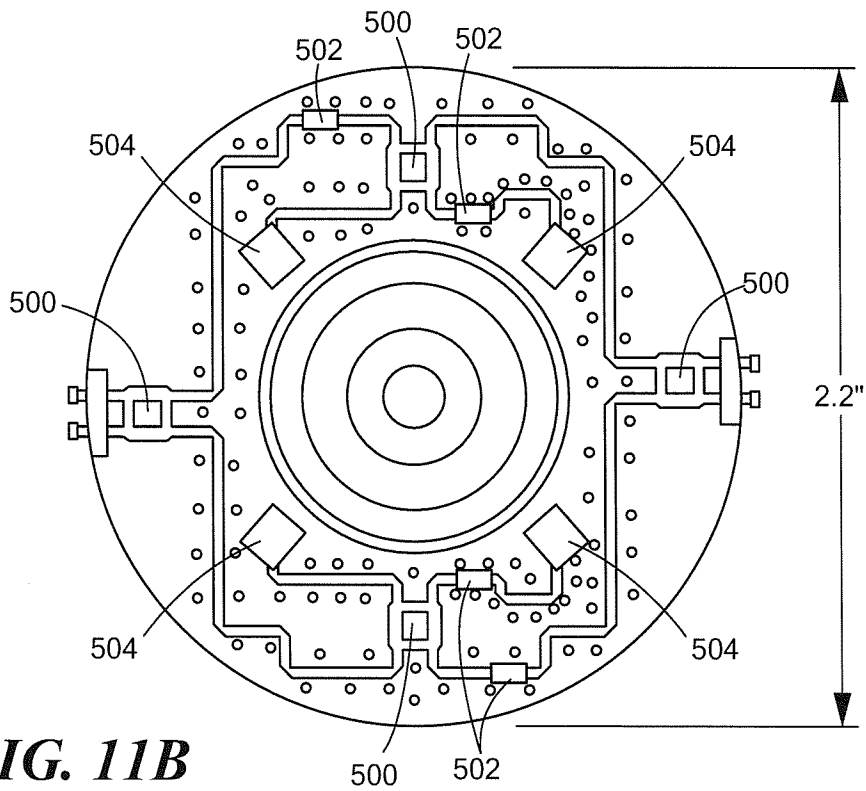

FIG. 11B

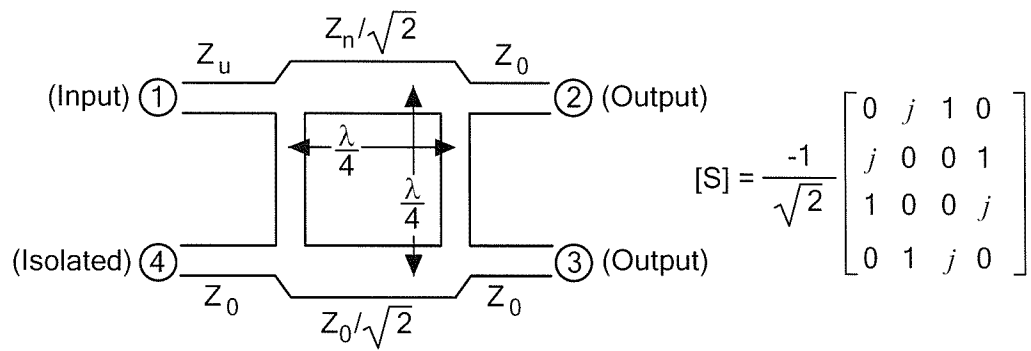

FIG. 12

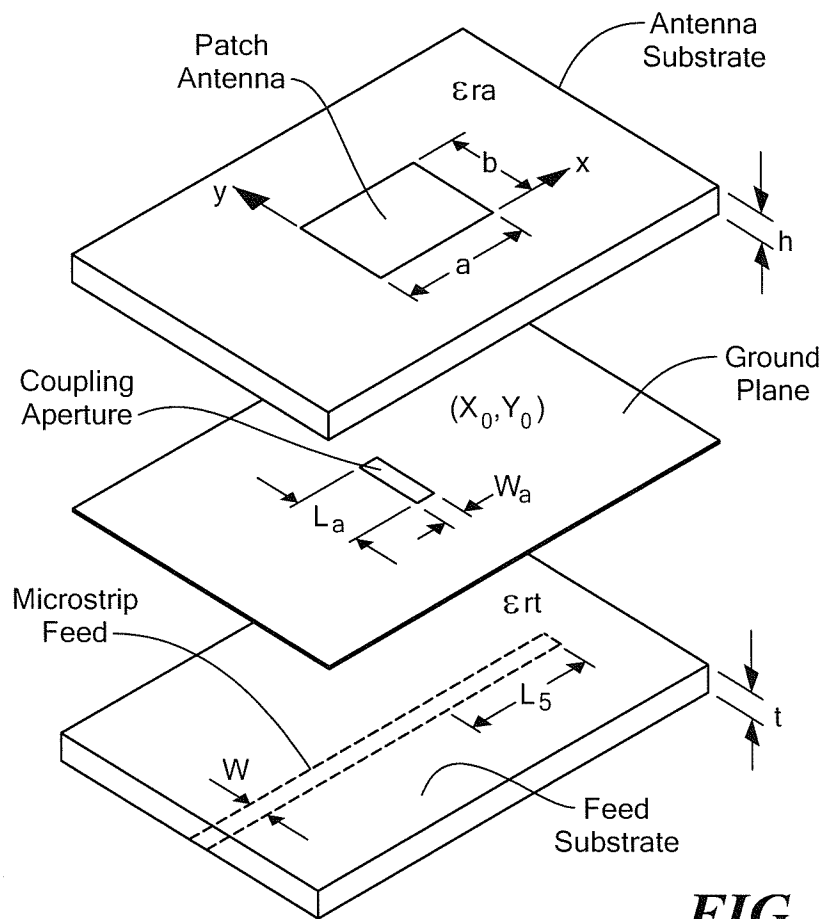
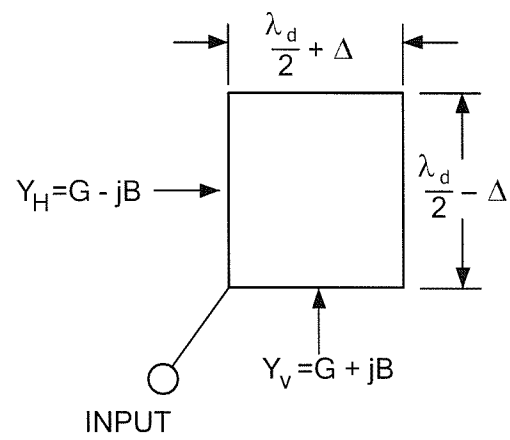

FIG. 13

11/13

**FIG. 14**

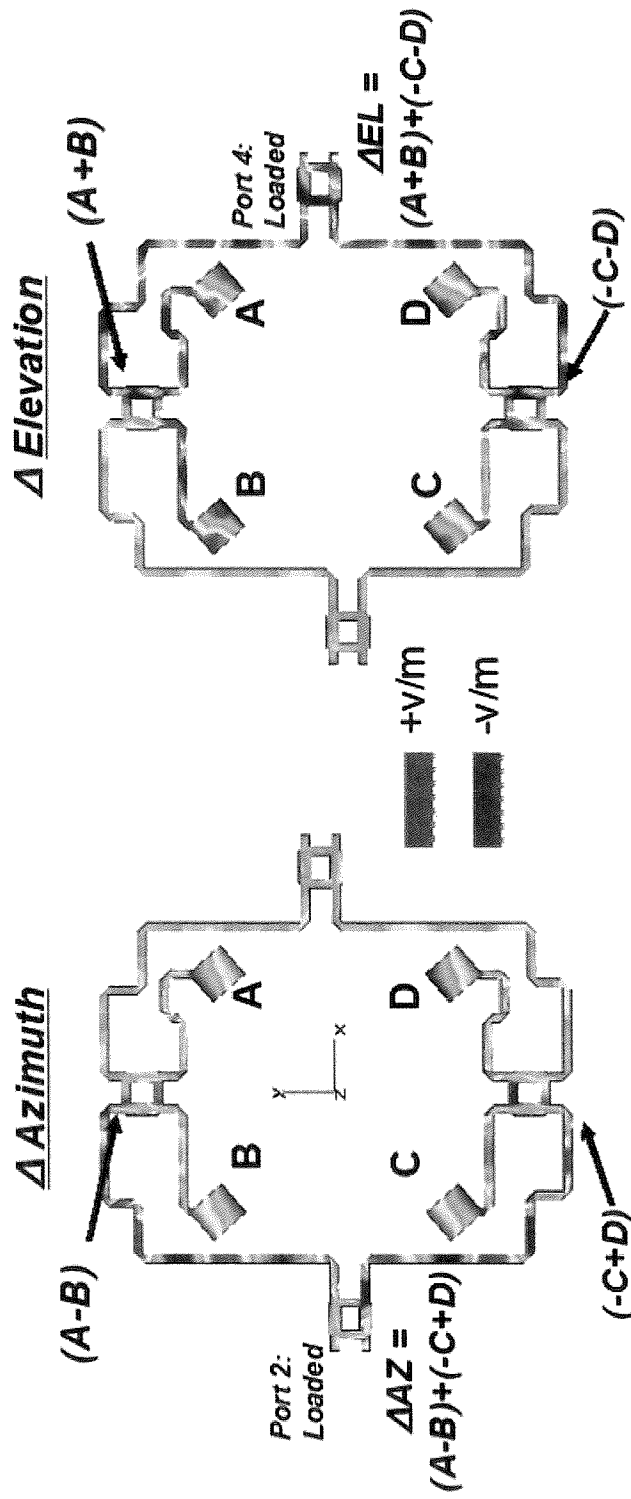

FIG. 15B

FIG. 15A

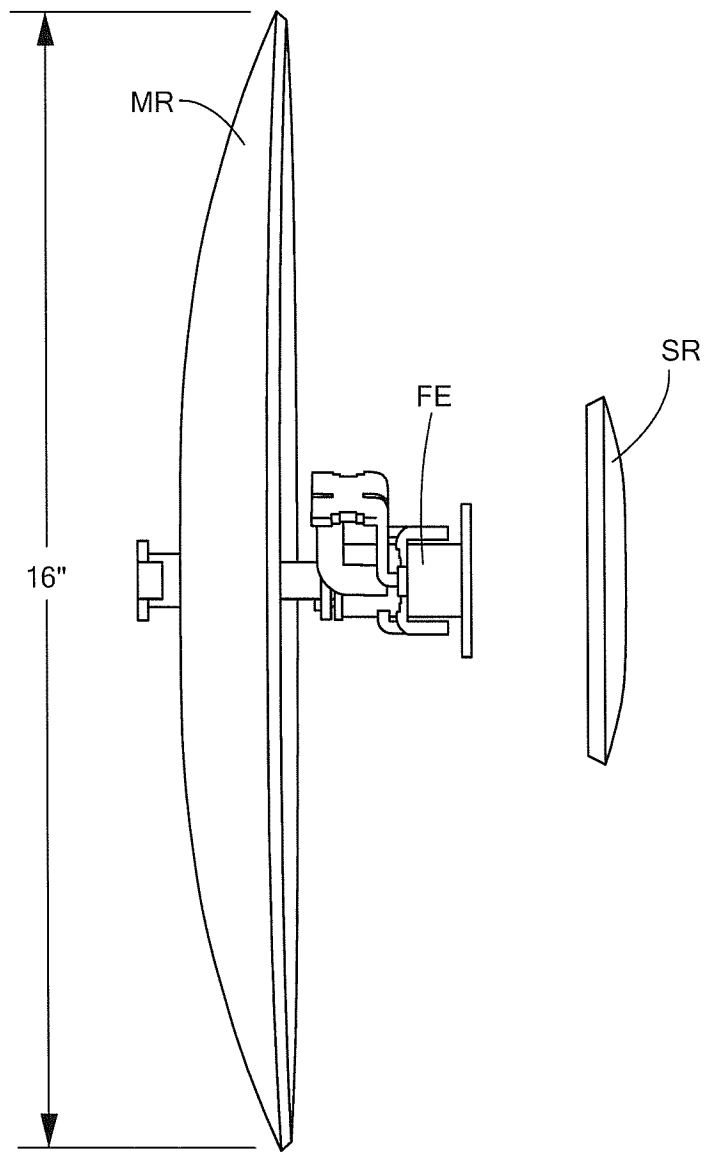

FIG. 16

INTERNATIONAL SEARCH REPORT

International application No
PCT/US2011/021989

A. CLASSIFICATION OF SUBJECT MATTER
 INV. H01Q5/00 H01Q13/02 H01Q19/08 H01Q21/28 H01Q25/02
 H01Q19/17
 ADD.
 According to International Patent Classification (IPC) or to both national classification and IPC

B. FIELDS SEARCHED
 Minimum documentation searched (classification system followed by classification symbols)
 H01Q

Documentation searched other than minimum documentation to the extent that such documents are included in the fields searched

Electronic data base consulted during the international search (name of data base and, where practical, search terms used)
 EPO-Internal

C. DOCUMENTS CONSIDERED TO BE RELEVANT

Category*	Citation of document, with indication, where appropriate, of the relevant passages	Relevant to claim No.
Y	WO 00/41266 A1 (CAMBRIDGE IND LTD [GB]; FLYNN STEPHEN JOHN [GB]; KING GERARD [GB]; BAI) 13 July 2000 (2000-07-13) the whole document	1-20
Y	US 2008/122683 A1 (HOWLEY ROBERT J [US] ET AL) 29 May 2008 (2008-05-29) paragraph [0057] - paragraph [0059]; figure 11	1-20
A	JP 60 018004 A (NIPPON TELEGRAPH & TELEPHONE) 30 January 1985 (1985-01-30) the whole document	4
A	US 5 041 840 A (CIPOLLA FRANK [US] ET AL) 20 August 1991 (1991-08-20) the whole document	1-20
	-/--	

Further documents are listed in the continuation of Box C.

See patent family annex.

* Special categories of cited documents :

<p>"A" document defining the general state of the art which is not considered to be of particular relevance</p> <p>"E" earlier document but published on or after the international filing date</p> <p>"L" document which may throw doubts on priority claim(s) or which is cited to establish the publication date of another citation or other special reason (as specified)</p> <p>"O" document referring to an oral disclosure, use, exhibition or other means</p> <p>"P" document published prior to the international filing date but later than the priority date claimed</p>	<p>"T" later document published after the international filing date or priority date and not in conflict with the application but cited to understand the principle or theory underlying the invention</p> <p>"X" document of particular relevance; the claimed invention cannot be considered novel or cannot be considered to involve an inventive step when the document is taken alone</p> <p>"Y" document of particular relevance; the claimed invention cannot be considered to involve an inventive step when the document is combined with one or more other such documents, such combination being obvious to a person skilled in the art.</p> <p>"&" document member of the same patent family</p>
--	--

Date of the actual completion of the international search 12 May 2011	Date of mailing of the international search report 19/05/2011
--	--

Name and mailing address of the ISA/ European Patent Office, P.B. 5818 Patentlaan 2 NL - 2280 HV Rijswijk Tel. (+31-70) 340-2040, Fax: (+31-70) 340-3016	Authorized officer Moumen, Abderrahim
--	--

INTERNATIONAL SEARCH REPORT

International application No
PCT/US2011/021989

C(Continuation). DOCUMENTS CONSIDERED TO BE RELEVANT		
Category*	Citation of document, with indication, where appropriate, of the relevant passages	Relevant to claim No.
A	US 2004/036661 A1 (HANLIN JOHN JOSEPH [US] ET AL) 26 February 2004 (2004-02-26) the whole document -----	1-20

INTERNATIONAL SEARCH REPORT

Information on patent family members

International application No PCT/US2011/021989

Patent document cited in search report	Publication date	Patent family member(s)	Publication date
WO 0041266	A1	13-07-2000	NONE
		AT 291282 T	15-04-2005
		AU 1883700 A	24-07-2000
		BR 0007421 A	04-12-2001
		CN 1337077 A	20-02-2002
		DE 60018705 D1	21-04-2005
		DE 60018705 T2	04-05-2006
		EP 1142062 A1	10-10-2001
		US 6720932 B1	13-04-2004

US 2008122683	A1	29-05-2008	NONE

JP 60018004	A	30-01-1985	NONE

US 5041840	A	20-08-1991	NONE

US 2004036661	A1	26-02-2004	NONE
