

April 10, 1951

G. G. OBENOUR
ELECTRIC SWITCH

2,548,678

Filed April 5, 1947

Fig. 1.

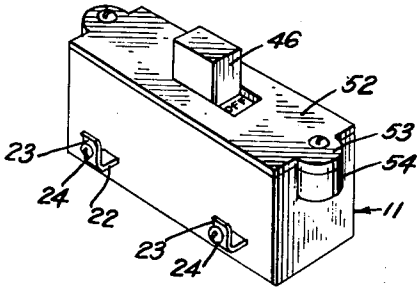

Fig. 6.

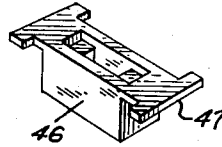

Fig. 2.

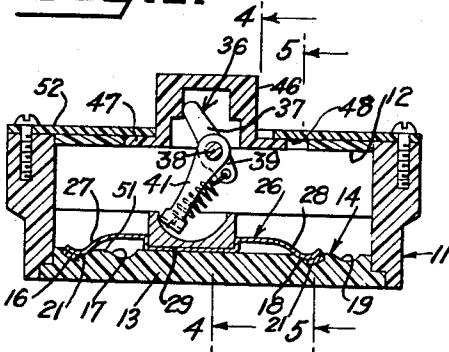

Fig. 3.

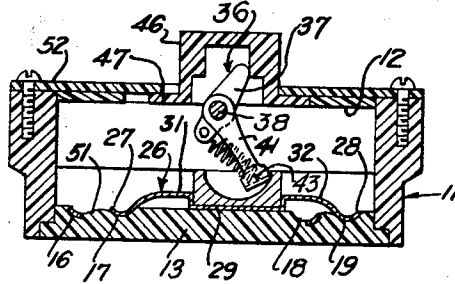

Fig. 4.

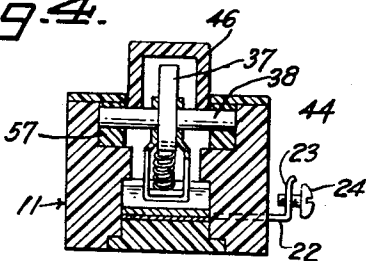

Fig. 7.

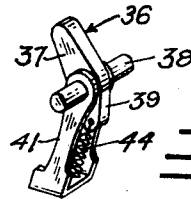

Fig. 5.

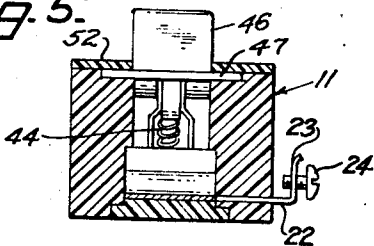
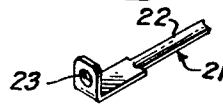

Fig. 8.



INVENTOR
GEORGE G. OBENOUR
BY *Arlington White*
ATTORNEY

UNITED STATES PATENT OFFICE

2,548,678

ELECTRIC SWITCH

George G. Obenour, San Francisco, Calif., assignor, by mesne assignments, to George Dissinger, Davis, Calif.

Application April 5, 1947, Serial No. 739,611

1 Claim. (Cl. 200—76)

1

The invention, in general, relates to means for making and breaking an electric circuit and more particularly relates to an improved switch of movable contact construction affording positive snap action between contacts and a greater area of positive contact without likelihood of scoring or otherwise burning or damaging of contacts.

Electric switches and switch boxes heretofore devised have been, for the large part, of relatively complex and cumbersome construction requiring appreciable manufacturing costs and maintenance expense, including frequent replacement of parts that become worn or fatigued. The present invention is directed to obviating inherent disadvantages of prior constructions and to afford a movable contact construction switch having durability yet simple of production and inexpensive to manufacture.

A primary object of the present invention is to provide an improved electric switch of the movable contact type wherein the movable contact is appreciably flexible but positive in action.

Another primary object of the invention is to provide an improved electric switch of the indicated nature which is additionally characterized by its rapid snap action to "off" and "on" positions thus avoiding all likelihood of pitting of contacts.

A still further object of my invention is to provide an improved electric switch having a minimum of parts and capable of constant use for appreciable periods of time without requiring replacement of parts.

Other objects of the invention, together with some of the advantageous features thereof, will appear from the following description of a preferred embodiment of the invention which is illustrated in the accompanying drawings. It is to be understood that I am not to be limited to the precise embodiment shown, nor to the precise arrangement of the various parts thereof, as my invention, as defined in the appended claim, can be embodied in a plurality and variety of forms.

Referring to the drawings:

Figure 1 is a perspective view of a preferred embodiment of the invention.

Figure 2 is a longitudinal sectional view of a preferred embodiment of the invention showing the movable contact in "on" position.

Figure 3 is a view similar to Figure 2 but showing the movable contact thrown to "off" position.

Figure 4 is a view taken on the section line 4—4 of Figure 2.

2

Figure 5 is a view taken on the section line 5—5 of Figure 2.

Figure 6 is a perspective view of the push button and slidable plate of the preferred embodiment of the invention.

Figure 7 is a perspective view of the rocker element employed in the preferred embodiment of the invention.

Figure 8 is a perspective view of the fixed terminal contact elements of the preferred embodiment of the invention.

In its preferred form, the improved electric switch of my invention preferably comprises a switch housing having a base with an inner undulatory surface, fixed contact elements in the recesses of said inner surface, together with a movable contact element, and means for moving said movable contact element with a rapid snap action to quickly engage and disengage said fixed contact elements of said base.

As particularly illustrated in Figures 1 to 3 inclusive of the accompanying drawings, my improved electric switch comprises a housing 11 preferably formed of electrical insulation material, such as a phenolic or urea condensate product with suitable filler, and so formed as to define an appreciable large inner chamber 12. The base 13 of the housing 11 preferably is formed with an inner undulatory surface, generally designated by the reference numeral 14, defining two sets of grooves 16, 17 and 18, 19 arranged in pairs at opposite sides of the center of the base. In grooves 16 and 18 are seated fixed contact elements 21 which conveniently are formed to the shape depicted in Figure 8 of the annexed drawings and which include a relatively long contact arm 22 formed to the same shape as the recesses 16 and 18, together with a terminal leg 23 integral with the arm 22 but extending at substantially right angles thereto. As indicated in Figures 1, 4 and 5, the terminal legs 23 of the fixed contact elements protrude from the housing 11 and each terminal leg is formed with an aperture for passing a screw 24 to enable attachment of electrical conductors thereto.

In accordance with my invention, a movable contact element 26 is slidably disposed on the inner surface 14 of the base of the switch housing 11, as clearly depicted in Figures 2 and 3 of the accompanying drawings. Movable contact element 26 preferably is formed with curved lateral extremities 27 and 28 and the degree of curvature of such extremities corresponds to the curved or concave shape of the recesses, 16 to 19 inclusive of the inner surface 14 of the base of the housing.

In addition, the movable contact element 26 contains a central channel member 29 preferably formed integral with the contact arms 31 and 32 extending laterally therefrom. As indicated in Figures 2 and 3, the movable contact element 26 is adapted to be moved to either one of two positions whereby the switch is placed either in an "on" or an "off" position. To this end, I preferably employ a rocker member 36, illustrated in perspective view in Figure 7 of the annexed drawings, including a head 37 and an integral rod 38 extending laterally from opposite sides of the head, and a depending short stem 39 extending from approximately the center of the bottom of the head. Suspended on or otherwise attached to or upon or around rod 38 is a U-shaped element 41 which carries on its horizontal leg 42 a retainer cup 43 in which the lower end of a spring 44 is seated; the spring 44 being coiled about the short stem 39 of the rocker member 36, as illustrated in Figures 2 to 5 inclusive. In operative position, the rocker member 36 is mounted with its rod 38 arranged transversely of the housing 11 and the depending short stem 39, the U-shaped element 41 and the coil spring 44 disposed immediately above the central channel member 29 of the movable contact element 26. To effect rocking of the rocker member 36, I preferably provide a push-button 46 and plate 47 as an integral unit, see Figure 6 of the drawings, which is slidably mounted in the switch housing in a groove 48 provided therein; the entire unit or push-button and plate being adapted to be moved to the right and to the left thereby engaging and moving the head 37 of rocker member 36 correspondingly with the result that the rod 38 is rocked carrying the short stem 39 beyond a center position whereafter the coil spring effects a rapid snap movement causing the movable contact element 26 to snap into position since the bottom leg 42 of the U-shaped element engages and pushes against the sides of the channel member 29 of the movable contact. Once the movable contact element 26 is snapped into position, the U-shaped element 41 holds it in such position until the push-button 46 is moved in the opposite direction. The push-button 46 is hollow as shown and serves to house the head 37 of the rocker member 36 and effectively to keep out dust and other debris from the parts of the switch.

It is to be especially observed that the arm 22 of the fixed terminal contacts 21 is arcuate in shape rather than fully concave so that each contact arm 22 occupies but one-half of the recesses or grooves 16 and 18 of the inner surface 14 of the base 13. Moreover, it is to be observed that the width of the lateral extremities 27 and 28 of the movable contact element 26 is substantially equal to the width of the recesses 16 and 18. Hence, when these lateral extremities of the movable contact 26 engage the arcuate shaped arms 22 of the fixed electrical contact elements 21 the engagement is complete transversely of the switch housing yet only one-half of the re-

cesses 16 and 18, such as the left hand side thereof, as illustrated in Figure 2 of the drawings is occupied by engaged contacts. With this arrangement of fixed contacts, there is no likelihood of burning or pitting of the contacts as the movable contact is snapped from side to side to engage and disengage such fixed contacts. It also is to be noted that the raised portions 51 of the undulatory inner surface 14 of the base, between the recesses thereof, serve to enhance the snapping action of the movable contact from inoperative or "off" position to operative or "on" position and vice versa in response to the throwing of the push-button 46.

For convenience of construction, the housing 11 is provided with a removable cover plate 52 having extensions 53 at the sides thereof which overlie bosses 54 formed on the sides of the housing; such extensions and bosses being provided with threaded apertures to receive screws 56 to tighten the cover in position. Cover plate 52 is enlarged on its inner side to afford the recess or groove 48 in which the push-button plate 47 slides, and also to provide a bearing boss 57 in which the rocker member rod 38 is journaled.

I claim:

In an electric switch, in combination, a housing having a chamber therein; said housing including an inner bottom surface having arcuate grooves therein arranged in spaced pairs at opposite sides thereof, a fixed arcuate contact in one groove of each of said pairs of grooves, a member within said chamber slidable on said bottom; said member having a recess therein and having arcuate resilient contact extremities seatable in said arcuate grooves, an actuating element to effect sliding of said member within said chamber for moving said resilient contacts into engagement with said fixed contacts as well as for moving said resilient contacts out of engagement with said fixed contacts, a U-shaped element seated in the recess of said member, and a spring coiled about said actuating element and seated in said U-shaped element; said spring being adapted to exert a positive force on said member to hold said resilient contacts in operative and in inoperative positions with respect to said fixed contacts.

GEORGE G. OBENOUR.

REFERENCES CITED

The following references are of record in the file of this patent:

UNITED STATES PATENTS

Number	Name	Date
1,312,550	Klein	Aug. 12, 1919
1,909,585	Jacobi	May 16, 1933
2,011,788	Winger	Aug. 20, 1935
2,023,094	Parker	Dec. 3, 1935
2,210,037	Meuer	Aug. 6, 1940
2,241,469	Meuer	May 13, 1941
2,254,729	Bryant et al.	Sept. 2, 1941