



INTERNATIONAL APPLICATION PUBLISHED UNDER THE PATENT COOPERATION TREATY (PCT)

<p>(51) International Patent Classification ³: G05G 9/08; F16H 3/08</p>	A1	<p>(11) International Publication Number: WO 81/00313 (43) International Publication Date: 5 February 1981 (05.02.81)</p>
<p>(21) International Application Number: PCT/EP80/00054 (22) International Filing Date: 15 July 1980 (15.07.80) (31) Priority Application Number: 7925590 (32) Priority Date: 23 July 1979 (23.07.79) (33) Priority Country: GB</p> <p>(71) Applicant (for all designated States except FR and US): MASSEY-FERGUSON SERVICE N.V. [NL/NL]; Abraham de Veerstraat 7a, Curaçao (NL). (71) Applicant (for FR only): MASSEY-FERGUSON S.A. [FR/FR]; 22, Avenue Galilée, F-92350 le Plessis Robinson (FR). (72) Inventor; and (75) Inventor/Applicant (for US only): LASOEN, Jean-Jacques [FR/FR]; 4, avenue des Prés Vendôme, F-78450 Ville Preux (FR).</p>		<p>(74) Agent: JONES, David, Bryn; Massey-Ferguson, Patent Department Stareton, Nr. Kenilworth CV8 2LJ, Warwickshire (GB). (81) Designated States: AT (European patent), AU, BR, CH (European patent), DE (European patent), FR (European patent), JP, NL (European patent), SE (European patent), US.</p> <p>Published With international search report With amended claims</p>
<p>(54) Title: RATIO SELECTING MECHANISM FOR A TRANSMISSION</p>		
<p>(57) Abstract</p>		
<p>A transmission ratio selecting mechanism including a ratio selector means (typically a hand lever), first and second ratio coupling members (36b, 37) movable to select a number of ratios in the forward and reverse drive directions of an associated transmission, and linkage means (65, 63, 54, 61, 62, 59, 57, 60 : 65, 63, 64, 70, 71, 68, 67, 69) for moving the ratio coupling members in response to movement of the ratio selector means. The ratio selecting mechanism includes disconnecting means (72, 73, 63, 64) for disconnecting one (37) of the ratio coupling members from the selector means during selection of the reverse ratios of the transmission. During selection of any reverse ratio both the gear coupling means are initially moved in synchronism in response to movement of the selector means to complete the first part of the selection of the particular reverse ratio, the disconnecting means is then operated, and selection of the reverse ratio is completed by further movement of only one (36b) of the ratio coupling means in response to further movement of the selector means. The selector means is arranged to return the ratio coupling members to synchronism on movement of the selector means to disengage the reverse ratio.</p>		

FOR THE PURPOSES OF INFORMATION ONLY

Codes used to identify States party to the PCT on the front pages of pamphlets publishing international applications under the PCT.

AT	Austria	KP	Democratic People's Republic of Korea
AU	Australia	LI	Liechtenstein
BR	Brazil	LU	Luxembourg
CF	Central African Republic	MC	Monaco
CG	Congo	MG	Madagascar
CH	Switzerland	MW	Malawi
CM	Cameroon	NL	Netherlands
DE	Germany, Federal Republic of	NO	Norway
DK	Denmark	RO	Romania
FI	Finland	SE	Sweden
FR	France	SN	Senegal
GA	Gabon	SU	Soviet Union
GB	United Kingdom	TD	Chad
HU	Hungary	TG	Togo
JP	Japan	US	United States of America

RATIO SELECTING MECHANISM FOR A TRANSMISSION

Technical Field

This invention relates to transmissions and in particular to transmission ratio selecting mechanism.

In such fields as, for example, tractors and fork-lift trucks there is a requirement for transmissions which provide several ratios in the forward and reverse drive directions and a manual forward/reverse shuttle facility.

The Applicant's co-pending Patent Application No..... (Based on U.K. Patent Application 7925589) describes and claims an improved form of transmission assembly which provides two forward and two reverse drive ratios and which when used in combination with one or more other transmission units is capable of providing a large number of forward and reverse drive ratios.

The provision of an efficient and compact ratio selecting mechanism for a transmission assembly of the type described and claimed in the Applicant's above referred to patent application and other transmission assemblies in which the selection of ratios involves the movement of more than one ratio coupling member (typically an axially movable sleeve or collar) is a difficult problem.

Disclosure of the Invention

It is an object of the present invention to provide an improved form of ratio selecting mechanism which is compact and which is suitable for use with transmission assemblies of, for example, the type described and claimed in the Applicant's previously referred to patent application.

According to the present invention there is provided a transmission ratio selecting mechanism including a ratio selector means, first and second ratio coupling members movable to select a number of ratios of an associated transmission, and linkage means for moving the ratio coupling



members in response to movement of the ratio selector means, the ratio selecting mechanism being characterised in that the linkage means includes disconnecting means for disconnecting one of the ratio coupling members from the selector means during selection of at least one of the transmission ratios, the arrangement being such that for the selection of said at least one ratio both the gear coupling means are initially moved in synchronism in response to movement of the selector means to complete the first part of the selection of said at least one ratio, the disconnecting means is then operated, and selection of said at least one ratio is completed by further movement of only one of the ratio coupling means in response to further movement of the selector means, the selector means being arranged to return the ratio coupling members to synchronism on movement of the selector means to disengage said at least one ratio.

The linkage means may include a member which is angularly movable in response to movements of the selector means with first and second cam members arranged to be moved by the angularly movable member to move the first and second ratio coupling members respectively, and with the disconnecting means arranged to disconnect drive from the angularly movable member to one of the cam members during selection of said at least one ratio.

Conveniently the disconnecting means includes a toggle linkage connected with the selector means for displacing the angularly movable member in a direction generally parallel to its axis of angular movement to disconnect drive from said one cam member.

In one form of selecting mechanism in accordance with the invention, in which the coupling members are required to be moved in opposite directions to select said at least one ratio, the selector means may be arranged on initial movement to move both coupling members in the same



direction to couple a gear wheel associated with one of said coupling members with an associated shaft and on further movement to operate said disconnecting means to move only the other coupling member in the opposite direction to couple a gear associated with the other coupling member with a further shaft to complete the selection of said at least one ratio.

A selecting mechanism of the form described in the preceding paragraph is particularly suitable for use in selecting the ratios of the transmission assembly of the Applicant's previously referred to patent application.

The first ratio engaging member comprises a coupling sleeve forming part of a non-synchromesh clutch unit and the second ratio engaging member may comprise a coupling sleeve forming part of a synchromesh clutch unit of the type specified, the linkage means ensuring that the non-synchromesh coupling sleeve is brought into engagement first during the selection of each ratio of the associated transmission.

References throughout this specification to synchromesh units or clutch units of the type specified refer to units which include a coupling member (for example a sleeve) axially slidable relative to a shaft for coupling a gear to said shaft, the coupling member being slidable from a non-engaged position in which said gear is not coupled to the shaft, through a synchronising position in which clutch members in the synchromesh unit are in frictional contact to synchronise the rotational speeds of said gear and shaft to a fully engaged position in which said gear is coupled to said shaft and axial movement of the coupling member is completed.

In a further form of the invention the linkage means includes a selecting mechanism characterised in that the



linkage means includes two generally parallel shift rails one for each ratio coupling member, and a selector member connected with the ratio selector means, the ratio selector member having two formations engageable with cooperating formations associated with the two rails, the formations on the selector member being movable in directions generally parallel to the direction of extension of the rails to move said rails and also being movable during the selection of said at least one ratio in directions generally perpendicularly to said directions of extension in order to disconnect one of the formations on the selector means from its cooperating rail formation thus disconnecting the associated ratio coupling member from the ratio selector means.

Where the selecting mechanism is used in the control of synchromesh clutch unit of the type specified using cam member as described above the cam member associated with the synchromesh sleeve preferably has three zones, a first zone contacted by the follower during movement of the coupling member towards the synchronising position, a second zone contacted by the follower during synchronisation and a third zone contacted by the follower after synchronisation has taken place and as the coupling member is moved towards the fully engaged position, the first, second and third zones being shaped so that a tangent to the cam surface at the point of contact with the follower during synchronisation makes a smaller angle with the direction of movement of the cam member than tangents drawn to points of contact with the first and third zones of the cam surface so that for a given selection force applied to the cam member a larger ratio engagement is applied to the follower during synchronisation than when the follower is in contact with the first and third zones.

Description of Drawings

The invention will now be described, by way of example only, with reference to the accompanying drawings in which:-

Figure 1 is a vertical section through an agricultural tractor transmission embodying the invention;

Figure 2 is a diagrammatic representation of part of an input gear set Z of the transmission part of which is not visible in Figure 1;

Figure 3 shows the provision of an additional planetary gear to double the number of ratios provided by the transmission.

Figure 4 shows the speed selection gate of the transmission;

Figure 5 shows the sequence of movement of the synchronising devices of a main change speed gear set X of the transmission;

Figure 6 shows the cam groove used to control the synchronising devices of the main change speed gear set X;

Figure 7 shows diagrammatically the manner in which the cam having the groove of Figure 6 is rotated;

Figure 8 shows in plan the manner in which the input set cam and auxiliary output set cam are sequenced relative to each other;

Figure 9 is a sectional view on the line A-A of Figure 8;

Figure 10 shows the cam grooves which control the auxiliary output set Y and the non-synchromesh coupler of the input gear set Z;

Figure 11 shows a side view in the direction of arrow B of Figure 8 of the upper half of the cam arrangement shown in Figure 8;

Figure 12 shows the range selection gate of the transmission;

Figure 13 shows the cam groove which controls the synchromesh coupler of the input gear set Z;

Figure 14 shows the sequence of movements of the synchromesh coupler of the input gear set;

Figure 15 shows graphically the ground speeds obtainable (in Kilometres/hour) in each ratio of a typical transmission in accordance with the invention at selected engine speeds.

Figure 16 shows the sequence of movements of the couplers of the auxiliary output gear set Y and the non-synchromesh coupler of the input gear set Z;

Figures 17 and 18 show in tabular form the gear wheels used to obtain each transmission ratio;

Figure 19 shows part of the cam groove of Figure 13 on an enlarged scale;

Figure 20 is a simplified representation of the geometry of the cam follower and groove shown in Figure 19;

Figure 21 shows a vertical section through an alternative ratio selection arrangement for input gear set Z and main change speed gear set X, and

Figure 22 shows schematically the plate-type cam member used in the arrangement of Figure 21.

Best Mode of Carrying Out Invention

The basic transmission construction is shown in Figure 1. It comprises a main four speed change speed gear set X, a two speed auxiliary output gear set Y, and a constant mesh input gear set Z capable of providing two forward speeds and two reverse speeds.

The main change speed set X comprises four gears 10, 11, 12 and 13 which are splined onto a lay shaft 14 and four constant mesh gears 15, 16, 17 and 18 which are rotatably mounted on the two portions 19 and 20 of the transmission output shaft.

The gears 15 and 16 are associated with clutch means in the form of a first synchronising unit 21 while the gears 17 and 18 are associated with further clutch means in the form of a second synchronising unit 22.

As will be appreciated, a first ratio is provided in the main change speed set X by sliding the sleeve 21a of the synchronising unit 21 to the left so that power is transmitted from the shaft 19 through gears 15 and 10 onto the lay shaft 14 and back to portion 20 of the output shaft via the auxiliary output train Y. In a similar fashion a second ratio is obtained by sliding the sleeve 21a to the right thus transmitting power from the shaft portion 19 via gears 16 and 11 to the lay shaft 14 and hence to the output shaft portion 20 via the output set Y.

Similarly, two further ratios can be obtained by sliding the second sleeve 22a of the synchronising unit 22 to the left and right respectively.

The output gear set Y comprises a gear 23 slidable on splines 24 provided on the output shaft portion 20. This gear 23 is engageable with a gear 25 which rotates with the lay shaft 14 to provide a low auxiliary output train ratio. By sliding the gear 23 on the splines 24 teeth 26 on the gear 23 can be meshed with co-operating teeth 27 on the gear 18 thus locking the gear 18 to the shaft portion 20 and providing a higher output train ratio via gears 13 and 18.

The input gear set Z comprises gears 28 and 29 which are rotatably mounted on an input shaft 30. These two gears are in constant mesh with gears 31 and 32 which are in turn rotatably mounted on the output shaft portion 19. Mounted behind the gears 28, 29, 21 and 32 as viewed in Figure 1, are two idler gears 33 and 34 shown diagrammatically in Figure 2 which mesh with gears 32 and 28 respectively. The idler gears rotate with a common shaft 35.

Associated with the gears 28 and 29 is a further clutch means in the form of a third synchronising unit 36 whose sleeve 36b can be used to couple either the gear 28 or the gear 29 to the input shaft 30. The clutch means for coupling either the gear 31 or 32 to the output shaft 19 comprises a simple sliding collar 37 which is coupled with shaft 19 and engageable with teeth 31a and 32a provided on gears 31 and 32 respectively.

The input gear set Z can be arranged to provide a high forward ratio by moving the sleeve 36b to the left to couple the gear 28 to the input shaft 30 and also sliding the collar 37 to the left to contact the gear 31 with the shaft portion 19. A low forward ratio can be provided by engaging the sleeve 36b with the gear 29 and sliding the collar 37 to the right to couple the gear 32 with the shaft portion 19.

A first reverse ratio is obtained from the input set Z when the sleeve 36b couples the gear 28 to the input shaft 30 and the collar 37 couples the gear 32 to the shaft portion 19. With the synchronising sleeve and the collar in these positions drive passes from the input shaft 30 via gear 28, gear 34, shaft 35, gear 33 and gear 32 to the shaft portion 19. A further reverse ratio is obtained by engaging the synchronising sleeve 36b with the gear 29 and moving the collar 37 to couple the gear 31 with the shaft portion 19. In this condition drive is transmitted from the input shaft 30 via gear 29, gear 32, gear 33, shaft 35, gear 34, gear 28 and gear 31 to the shaft portion 19.

Thus the input set Z, is capable of providing two forward speeds and two reverse speeds which enable the whole transmission to provide, if required, sixteen forward speeds and sixteen reverse speeds.

Input set Z is the subject of the Applicants previously referred to Application No.
(Based on U.K. Patent Application No. 7925589).

Since, as described below, the collar 37 is always arranged to couple either the gear 31 or 32 to the output shaft portion 19 before the synchronising sleeve 36b couples either the gear 28 or 29 to the input shaft 30, the collar 37, when coupling the gear 31 or 32 to the shaft portion 19, only has to overcome the relatively low rotational inertia of the gears of input train Z since the higher inertia items such as the shaft 30 and the associated clutch parts (not shown) are not at that time coupled by the synchronising device 36. This makes it possible to use a simple sliding collar 37 rather than another synchronising unit thus making input set Z significantly cheaper and also more compact than if another synchronising unit was used in place of collar 37. In this later regard it will be noted that the maximum radial dimension of collar 37 is significantly less than that of sleeve 36b thus allowing shafts 30 and 19 to be appreciably closer together than if collar 37 were to be replaced by another synchronising unit. This allows the whole transmission to be of a more compact design.

If desired, the speed range can be further increased by the addition of a two speed planetary gear on the input end of the transmission as shown in Figure 3. The planetary gear includes a sun wheel 38 formed integrally on an input shaft extension 39, planet gears 40 mounted on a planet carrier 41, and an annulus gear 42 which is held fixed.

A slidable sleeve 43 can occupy the position shown in Figure 3 in which it couples the planet carrier 41 with the previously described input shaft 30 to provide a first planetary ratio or can be slid axially to engage teeth 44 formed on the input shaft extension 39 to directly couple the input shaft extension to the shaft 30 thus locking out

the planetary gear to provide a second ratio.

It will be appreciated that mechanical coupling of the two speed planetary gear using the sleeve 43 can be replaced by a hydraulically operated clutch arrangement.

The two speed planetary gear, whether mechanically or hydraulically coupled, can be used as an under-drive or overdrive as required.

As indicated above the transmission (without the use of the two speed planetary gear shown in Figure 3) provides sixteen forward speed and sixteen reverse speeds.

These forward speeds are grouped into four ranges A, B, C and D as shown in Figure 15. Range A is a creeper range, ranges B and C are the field working ranges and range D is the road speed range. Figure 15 indicates the ground speeds obtainable (in Kilometer/hour) in each ratio of a typical transmission embodying the invention at selected engine speeds and clearly illustrates the flexible nature of the transmission and the good spread of ground speeds. The legend at the top right hand corner of Figure 15 indicates the selected engine speed p, q, r and s on the block marking, these speeds being 2400, 2040, 1730 and 1400 engine revolutions per minute respectively (2400 revs/min being the rated engine speed of the engine).

Selection of these ranges is under the control of a lever (not shown) which moves in a gate 66 shown in Figure 12. Each range A, B, C and D has four sub-ratios 1 to 4 selected by a second lever (not shown) which moves in a straight gate 49 of Figure 4.

Also, the gate 66 controls the selection of the four basic reverse ranges R1, R2, R3 and R4 which again each have four sub-ratios 1 to 4 controlled by gate 49.



Thus using the two gates 49 and 66 sixteen forward and reverse ratios can be selected.

The transmission also provides a "park" facility which is selected on gate 49 and designated "P" and which locks the transmission up to function as a parking brake.

All the ratios of the main change speed set X, the two speed auxiliary output set Y, and the constant mesh input set Z are selected by rotatable cams having cam tracks which are engaged by followers which in turn move gear selector forks to make the required gear changes.

The main change speed set X is controlled by the lever which moves down the straight gate 49 shown in Figure 4. As can be seen between each ratio position a neutral condition is provided and the park facility designated "P" is available in which the set X is locked-up by simultaneously engaging the two synchronising devices 21 and 22.

The left and right hand portions of Figure 5 show schematically the shifting sequence of the two synchronising units 21 and 22 respectively. Figure 5 indicates the synchronising units are arranged so that normally when one synchronising unit is operated to engage a gear the other synchronising unit is in its neutral condition N. The facility is provided to simultaneously engage the first and fourth gear ratios provided by gears 15 and 18 in order to place the transmission in its park condition P.

The schematic shift pattern shown in Figure 5 is in practice translated into a single cam groove 51 formed in the periphery of a rotatable cam member 50. For ease of reference the development of this cam member is shown in Figure 6 from which it will be readily apparent that the length EF of the groove 51 corresponds to the left hand portion of Figure 5 and the length GH of the groove 51 corresponds to the right hand portion of Figure 5.

The two cam followers which operate in groove 51 thus share a common neutral portion GI of the groove. This arrangement in which two followers operate in the same groove 51 greatly simplifies the cam arrangement and saves a considerable amount of space inside the transmission housing by avoiding the need for two separate cams and their associated rotating means.

The cam 50 is shown diagrammatically in Figure 7 and is arranged to be rotated by a toothed sector 52 which engages teeth 53 formed on the cam. Thus pivoting of the toothed sector 52 as indicated by the arrow W in Figure 7 results in rotation of the cam 50 as indicated by the arrow K.

Figure 8 shows the cam operating mechanism used in the selection of the ratios in the auxiliary output set Y and the input set Z. The cam 50 is positioned behind this cam arrangement as viewed in Figure 8, the sector 52 being secured to a sleeve 54 which is rotated by a lever 55 coupled with the gear selection lever which moves in gate 49.

As can be seen from Figure 8 the lever 55, sleeve 54, sector 52 and cam 50 are carried by a detachable cover 120 which is located on the right hand side of the transmission housing in the position indicated by dotted circle 120 in Figure 1. This cover has support webs 121 and 122 which project through a circular aperture 123 in the housing and which support the cam 50 and cams 59 and 68 referred to below.

Turning now to the control of the auxiliary output set Y and the movement of the collar 37, this is under the control of cam tracks 56 and 57 cut in the periphery of a rotatable cam 59. These cams, whose developments are shown in Figure 10, are representations of the shift pattern for the auxiliary output set Y and the collar 37 as shown schematically in Figure 16. Thus the cam groove 56

corresponds to the left hand portion of Figure 16 and the groove 57 corresponds to the right hand portion of Figure 16.

A cam follower shown at 60 in Figure 11 engages the groove 57 while a corresponding follower (not shown) engages the groove 56. As these followers follow along their respective grooves the necessary axial sliding movement of the associated selector forks to effect the movement of the gear 23 and the collar 37 occurs. As will be appreciated, since the throw required to change the operating ratio of the auxiliary output set Y is large this must be reflected in the sideways throw T of the cam groove 56 which is appreciably greater than that of groove 57.

As can be seen from Figures 10 and 11 by appropriate operation of the cam 59 four different speed ratios can be obtained using the two positions of the gear 23 and the two alternative positions of the collar 37.

The cam 57 is rotated by a geared sector 61 which engages a gear 62 formed on the cam 59 in a similar manner to the way in which the selector 52 engages the gear 53. The sector 61 is splined onto a shaft 63 at 64 and the shaft 63 is rotated via an arm 65 connected with the gear lever (not shown) which moves in the gate 66 shown in Figure 12. Shaft 63 is again carried by cover 120. Thus movement of the lever which moves in the gate 66 rotates the shaft 63 and hence rotates the cam 59 via sector 61 and gear 62.

Control of the synchronising unit 36 is effected by a cam groove 67 cut in a cam 68. The development of this groove is shown in Figure 13 and is again simply the shift pattern for the synchronising unit 36 as shown schematically in Figure 14.

The cam groove 67 is engaged by the follower 69 shown in Figure 11. Rotation of the cam 68 is effected by a

geared sector 70 which is splined onto the shaft 63 at 64 and drives a gear 71 formed on the cam 68. As previously described, for forward drive ratios the synchronising sleeve 36b and collar 37 are either both moved to the left or to the right from their neutral positions. This requires synchronisation of the rotation of cams 59 and 68. This synchronisation is achieved by virtue of the fact that both gear sectors 61 and 70 are rotated from the same splined connection 64 on the shaft 63.

When the input train Z is operated to give a reverse drive ratio the synchronising sleeve 36b and collar 37 are moved one to the left and one to the right of their neutral positions in order to transmit drive to the idler gears 33 and 34.

In order that the synchronising sleeve 36b and collar 37 can occupy positions on opposite sides of their neutral position it is necessary to break the synchronisation of the rotation of cams 59 and 68. This is achieved by axially displacing the shaft 63 so that the splines 64 disengage the gear sector 61 whilst remaining engaged with the sector 70. This sliding of the shaft 63 is achieved by either pulling or pushing on the cable 72 which operates the toggle linkage 73 secured to the end of the shaft 63.

Thus, for example, when reverse range R1 is selected on the gate 66 this is achieved in two states. Firstly if the lever is not already in the range A position it is moved to this position and in so doing rotates the two cams 59 and 68 in synchronism under the control of shaft 63 to the appropriate position for range A. Next the lever is moved from the range A position to the reverse range R1 position. This movement firstly displaces the cable 72 which in turn moves the shaft 63 thus disengaging sector 61 and hence leaving the output set Y and collar 37 in the range A position and secondly rotates the cam 68 in the reverse direction to move

the synchronising sleeve 36b from the range A position to the range R1 position.

As will be appreciated the transmission provides four manual forward/reverse shuttle changes between the A, R1 : B, R3 and C, R4 positions. Each of these shuttle changes involves the movement of only the synchronising coupling sleeve 36b to the right or left as the case may be.

Figure 17 and 18 show in tabular form the gear wheels used in the transmission shown in the drawings to provide each of the transmission's thirty-two ratios. It has been found possible to arrange for several of the gear wheels used in the transmission to have the same number of teeth enabling either actual common gear wheels or at least common gear wheel hobbing machinery to be used to provide these gear wheels thus giving a significant economy in the manufacture of the transmission by still further reducing the number of different gear wheels provided. In one example of the transmission described, gear wheel 11 has the same number of teeth as gear wheel 32, gear wheel 13 has the same number of teeth as gear wheel 28, gear wheel 16 has the same number of teeth as gear wheel 29, and gear wheel 18 has the same number of teeth as gear wheel 31.

As stated above ranges B and C are the two field working ranges while range D is the road speed range. Thus, for example, when a tractor is being operated in a field with a particular implement it is normally operating in either range B or range C and there is normally little requirement to switch between these two ranges although the operator will require the facility to switch from which ever

of these ranges is being used to the road speed D range on, for example, his journey to and from the field. For this reason the range selection gate 66 shown in Figure 12 is laid-out with the road speed range D positioned between the two field working ranges B and C so that range D can be reached directly from either range B or range C. It will also be seen from a consideration of Figure 17 that changing to range D from range B or range C requires only one change in the transmission coupling. For example, changing to range C from range D only involves the sliding of coupling sleeve 36b and changing to range B from range D only involves the sliding of gear 23. This compares favourably with changes between ranges B and C which involve sliding of both coupling sleeve 36b and gear 23. Thus, with the range D position between the range B and C positions, changes between each of the adjacent ranges on the gate 66 only involves one change in the transmission coupling.

The profiles of cam grooves 56 and 57 are basically straight or large radius curved tracks jointed together smoothly by the use of appropriate radii 56a, 56b and 57a, 57b (see Figure 10). This simple profile is possible since the ratio changes controlled by these grooves are not synchronised.

However, the grooves 51 and 67 which control the synchronised changes are "wavy" in nature. Thus for example, referring to Figure 13 the groove 67 makes the change from portion 67a to 67b by way of radiused portions 67c, 67d, 67e and 67f on the left side of the groove and complementary radiused portion 67g, 67h, 67i, and 67j on the other side of the groove. The wavy shape of these grooves is the subject of the Applicants co-pending Application No. 7925588. (Based on U.K. Patent Application 7925588).



Comparison of Figures 10 and 13, which are laid out on the same scale, indicates that after a given cam movement R of cam 68 a sideshift S away from neutral of the follower engaged in the groove 67 has occurred whereas for the same movement R of cam 59 a larger sideshift S1 is obtained. This ensures that the sleeve 37 is engaged with teeth 31a or 32a before the synchronising unit 36 couples the gear 28 or 29 to the shaft 30.

In practice the sideshift S is arranged to take up the clearances in the synchronising unit and bring the synchronising clutch parts 36a into engagement while the sideshift S1 is sufficient to partially engage the sleeve 37 with either teeth 31a or 32a. After synchronisation has taken place the groove 67 effects further axial sliding of the synchronising coupling sleeve 36b thus coupling gear 28 or 29 to the shaft 30. During this further movement along groove 67 the sleeve 37 is moved to its full engaged position by groove 57 completing a total sideshift movement of S2 as shown in Figure 10.

The shape of groove 67 and the manner in which it effects movement of the associated follower and sleeve will now be discussed in more detail. Figure 19 shows part of the groove 67 of Figure 13 on an enlarged scale. Dotted circle 100 indicates the neutral position of the cam follower which engages the groove 67 at contact point L. If a force F is now applied to the cam 68 this will cause the cam follower to move the distance S to the right as viewed in Figure 19, as a result of contact with the zone P of the side of the groove 67, to take up the clearances in the synchronising clutch parts into frictional engagement in order to carry out their synchronising action. Dotted circle 101 shows the position of the follower when the synchronising clutch parts are actually carrying out the synchronising action and the follower is contacting the groove 67 at the point M on zone Q of the cam.

As can be seen from Figure 19 tangents 102 and 103 to the side of the groove 67 at contact points L and M respectively are inclined at angles α' and α respectively to the line of action of the force F applied to the cam from the selector lever. Typically angle α' will be 45 degrees and angle α will be less than 20 degrees and typically 8 to 13 degrees (say 10 degrees). The use of a small angle α during synchronisation ensures that the axial force FF actually applied to the follower and hence to the associated selector fork is as large as possible so that the effort which must be applied to the gear selector lever in order to engage any synchromesh gear is maintained as low as possible.

The fact that the force FF is larger for smaller angles of α can be readily seen from the simplified two dimensional representations of the geometry of cam follower and groove as shown in Figure 19 in which the cam groove wall is represented by the straight line β at an angle α to the direction of application of the force F applied to the cam.

If the cam follower initially contacts the wall (line β) at point O and the F force moves the cam through a small peripheral distance OO' so that the wall occupies the dotted line position β' it will be seen that the point of contact of the follower with the groove wall will have moved axially to the position O''.

Equating the work input and output of the cam and roller system we have:-

$F \times \text{cam movement} = FF \times \text{axial displacement of cam follower}$

$F \times OO' = FF \times OO''$

$$F = \frac{FF \times OO''}{OO'}$$

$$\underline{F = FF \tan \alpha}$$

Thus as α decreases so the value of FF increases for a given value of F.

After synchronisation has taken place the synchronising coupler is free to move axially and engage the desired gear ratio, circle 104 in Figure 19 showing the fully engaged position. This movement of the synchronising coupler is brought about by the contact of the zone N of the side of the groove 67 (corresponding to say portion 67d or Figure 13) with the groove follower. Since it is not necessary to apply the same level of force to the synchronising coupler after synchronisation has occurred the curved zone N of the side of the groove is generally inclined at a larger angle. This larger inclination also means that a larger axial movement of the selector fork and associated coupler can be obtained for a given amount of rotation of the cam when the follower is operating on the zone N of the side of the groove.

Thus the shape of the zones P and N of the side of the groove 67 are chosen to give a large axial movement of the cam follower for a given amount of rotation of the cam while the shape of zone Q adjacent the contact point M is chosen to provide the greatest axial force during actual synchronisation.

It will be appreciated that at the contact point

$$L \quad FF_L = F/\tan 45^\circ = F/1$$

Similarly at the contact point M

$$FF_M = F/\tan 10^\circ = F/.1736$$

Thus the force generated at the follower is approximately 5.7 times greater at contact point M. Since the force required during synchronisation is approximately five times more than required at the neutral L position this results

in a substantially constant load being required at the selector lever for all selector lever positions.

Typically the mean force multiplication ratio of the selector mechanism (that is the ratio $\frac{\text{Force at the selector fork}}{\text{Force at the drivers hand}}$) is about 5 to 1 while this ratio is about 2.3 to 1 at the neutral position and about 13 to 1 when synchronisation is occurring. The average multiplication ratio of the cam on its whole travel is

$$\frac{\text{total cam displacement}}{\text{total selector fork displacement}} = C/T \text{ from Figure 19}$$

Typically this ratio is of the order of 2 to 1.

The above described "wavy" cam shape is also employed in the other parts of cam 68 and on cam 50 which controls synchronising units 21 and 22.

Also, although in the construction described above, the cam tracks engaged by the various followers are provided by grooves cut into cam members it will be understood that the tracks could be provided by raised circumferentially extending projections formed on the peripheral surfaces of the cams. Additionally instead of each follower moving between opposed walls provided by a groove or raised projections, the follower could be biased into engagement with a single circumferentially extending wall.

Figure 21 shows an alternative form of ratio selection arrangement for input set Z and main change speed gear set X.

The input set Z is controlled by a selector member 130 which is pivotally supported at 131 on a rotatable sleeve 132 carried by a removable cover 133 which closes a transmission casing aperture similar to the aperture 123 referred to above. The lower end of member 130 is connected at 134 with a twin pronged selector member 135 which is splined at 136 for

axial sliding movement within sleeve 132.

The prongs 137 and 138 of selector member 135 engage recesses 139 and 140 in members 141 and 142 carried by selector rails 143 and 144 respectively. Rails 143 and 144 are connected with synchronising unit 36 and collar 37 respectively.

Selector member 130 is connected with a selector lever 145 as shown diagrammatically at 146 in Figure 24, this lever being movable along an S - shaped gate shown diagrammatically at 147.

Figure 21 shows the lever in a neutral position in which neither synchronising unit 36 nor collar 37 is coupling any of the gears 28, 29, 31, 32 of input set Z to their associated shafts. In order to couple gears 29 and 32 with shafts 30 and 19 the selector member 130 is rotated with the sleeve 132 and member 135 about axis 148 from the position shown in Figure 21 in a counter clockwise sense when viewed in the direction of arrow C by the movement of lever 145 to the position A/C of gate 147. This moves both selector rails 143 and 144 rearwardly thus coupling gears 29 and 32 to shafts 30 and 19. As indicated by the gate marking A/C either range A or range C is engaged by this movement of lever 145 depending on the position of gear 23 of set Y. In this alternative selection arrangement the movement of gear 23 can be achieved by a convenient means, for example, this can be achieved electro-hydraulically at the press of a button which operates a solenoid-operate valve controlling the supply of hydraulic fluid to a hydraulic actuator.

In order to ensure that collar 37 engages before synchronising unit 36 the clearances in the connecting linkage (not shown) between prong 137 and the synchronising unit 36 are arranged to be greater than the clearances in

the connecting linkage (not shown) between prong 138 and the collar 37.

In a similar fashion movement of lever 145 to the B/D position rotates the selector member 135 in a clockwise sense about axis 148 thus coupling gears 28 and 31 to shafts 30 and 19 and engaging range B or D depending on the position of gear 23.

A reverse RA is obtained by pivoting lever 145 to the left from the B/D position to pivot member 130 in an anti-clockwise sense about pivot 131 and thus disengaging prong 138 from recess 140. This disconnects the rail 144 from the selector mechanism and allows the selection of reverse range RA to be completed by the movement of the lever 145 to the RA position of gate 147 which rotates member 135 in a counter clockwise sense about axis 148 and moves sleeve 36b rearwardly to couple gear 29 to shaft 30.

A further reverse range RB is obtained by pivoting lever 145 to the right from the A/C position to pivot member 130 in a clockwise sense about pivot 131 and thus disengage prong 138 from recess 140 into recess 139 with prong 137. This disconnects the rail 144 from the selector mechanism and allows the selection of reverse range RB to be completed by the movement of the lever 145 to the RB position of gate 147 which rotates member 135 and a clockwise sense about axis 148 and moves sleeve 36b forwardly to couple gear 28 to shaft 30.

As will be appreciated two reverse ranges are selectable with the gear lever in the RA position dependent on the position of gear 23 and similarly two reverse ranges are selectable with the gear lever in the RB position dependent on the position of gear 23.

The four speed main change speed gear set X is con-

rolled by a rotary selector member 150 which is supported by the cover 133 and is connected (as shown diagrammatically at 151) with a further selector lever 152 which moves in a straight gate 153. Member 150 is connected by shaft 154 with a plate-type cam member 155 (in a manner not shown) so that rotation of member 150 rotates shaft 154 and thus cam 155 about an axis 156.

Cam member 155 is shown schematically in Figure 22 when viewed in the direction of arrow C and includes a slot 157 for the passage of selector member 135 and two cam tracks 158 and 159 for the operation of synchronising units 22 and 21 respectively. Each cam track is engaged by a separate follower 160, 161, only the follower 161 of cam track 158 being visible in Figure 21, and the centres of both followers 160, 161 are located and maintained on line 170 in Figure 22.

With the lever 152 in the position shown in Figure 21 both followers line in the neutral positions indicated by dotted circles 160 and 161 in Figure 21. Each follower is connected with the associated synchronising unit by an arm and shift rod as shown by arm 162 and rod 163 of follower 161.

As will be appreciated if the lever 152 is rotated rearwardly to the second speed position the cam member 155 is rotated counter clockwise as viewed in Figure 22 and the followers occupy the position 160' and 161' respectively this moving the sleeve 21a rearwardly to engage the second speed of the main change speed gear set X.

In a similar fashion if lever 152 is rotated forwardly from the neutral position shown in Figure 21 to the third speed position cam member 155 is rotated in a clockwise sense as viewed in Figure 22 and the followers occupy the positions 160" and 161" in the cam tracks thus moving the

sleeve 22a forwardly to engage the third speed of the gear set X.

As will be appreciated the first and fourth speeds of gear set X can be selected by movement of the lever 152 to the appropriate positions of gate 153 and results in follower positions 160''', 161''', and 160'''' and 161'''' respectively in Figure 22.

As indicated above Figure 22 shows the cam member 155 schematically and the two cam tracks 158 and 159 are not depicted as having the 'wavy' cam shape described above in detail with reference to Figure 19 and 20. It will be understood, however, that in practice the wavy cam shape will be used on cam tracks 158 and 159 to reduce the lever effort required at synchronisation.

CLAIMS:

1. A transmission ratio selecting mechanism including a ratio selector means, first and second ratio coupling members (36b, 37) movable to select a number of ratios of an associated transmission, and linkage means (65, 63, 54, 61, 62, 59, 57, 60 : 65, 63, 64, 70, 71, 68, 67, 69) for moving the ratio coupling members in response to movement of the ratio selector means, the ratio selecting mechanism being characterised in that the linkage means includes disconnecting means (72, 73, 63, 64) for disconnecting one (37) of the ratio coupling members from the selector means during selection of at least one of the transmission ratios, the arrangement being such that for the selection of said at least one ratio both the gear coupling means are initially moved in synchronism in response to movement of the selector means to complete the first part of the selection of said at least one ratio, the disconnecting means is then operated, and selection of at least one ratio is completed by further movement of only one (36b) of the ratio coupling means in response to further movement of the selector means, the selector means being arranged to return the ratio coupling members to synchronism on movement of the selector means to disengage said at least one ratio.
2. A selecting mechanism according to claim 1 characterised in that the linkage means includes a member (63) which is angularly movable in response to movements of the selector means, first (68) and second (59) cam members being arranged to be moved by the angularly movable member to move said first (36b) and second (37) ratio coupling members respectively, and the disconnecting means (72, 73, 63, 64) is arranged to disconnect drive from the angularly movable member to one (59) of the cam members during selection of said at least one ratio.
3. A selecting mechanism according to claim 2 characterised

- in that the disconnecting means (72, 73, 63, 64) is arranged to displace the angularly movable member (63) in a direction generally parallel to its axis of angular movement to disconnect drive to said one cam member (59).
4. A selecting mechanism according to claim 3 characterised in that the disconnecting means includes a toggle linkage (72, 73) connected with the selector means for displacing the angularly movable member (63).
5. A selecting mechanism according to claim 3 or claim 4 characterised in that the angularly movable member comprises a shaft (63) with a splined portion (64) which engages first and second drive members (61, 70) for angularly displacing the first and second cam (68, 59) respectively, the disconnecting means (72, 73) being arranged to axially displace the shaft to disengage one (61) of the drive members from the splined portion (64).
6. A selecting mechanism according to claim 5 characterised in that the drive members each comprise a toothed sector (61, 70) which engages the splined portion (64) and gear teeth (62, 71) associated with each respective cam (59, 68).
7. A selecting mechanism according to any one of claims 2 to 6 characterised in that the cam members (59, 68) each comprise a cylindrical member with a cam formation (57, 67) formed around its periphery, each formation being engaged by a cam follower (60, 69) arranged to move the associated engaging member (36b, 37).
8. A selecting mechanism according to claim 1 characterised in that the linkage means includes two generally parallel shift rails (143, 144) one for each ratio coupling member (36b, 37), and a selector member 135 connected with the ratio selector means (145), the ratio selector member having two formations (137, 138) engagable with cooperating formations (139, 140) associated with the two rails (143, 144),

the formations on the selector member being movable in directions generally parallel to directions of extension of the rails to move said rails and also being movable during the selection of said at least one ratio in directions generally perpendicularly to said directions of extension in order to disconnect one (138) of the formations on the selector means from its cooperating rail formation (140) thus disconnecting the associated ratio coupling member (37) from the ratio selector means (145).

9. A selecting mechanism according to any one of claims 1 to 8 characterised in that the coupling members (36b, 37) are required to be moved in opposite directions to select said at least one ratio, the selector means being arranged on initial movement to move both coupling members in the same direction to couple a gear wheel associated with one (37) of said coupling members with an associated shaft (19) and on further movement to operate the disconnecting means (72, 73, 63, 64) to move only the other coupling member 36b) in the opposite direction to couple a gear associated with said other coupling member with a further shaft (30) to complete the selection of said at least one ratio.

10. A selecting mechanism according to any one of claims 1 to 9 characterised in that the first ratio coupling member comprises a coupling sleeve (37) forming part of a non-synchromesh clutch unit and the second ratio coupling member comprises a coupling sleeve (36b) forming part of a synchromesh clutch unit of the type specified, the linkage means ensuring that the non-synchromesh coupling sleeve (37) is brought into engagement first during the selection of each ratio of the associated transmission.

11. A selecting mechanism according to claim 10 when directly or indirectly dependent on claim 2 characterised in that the first and second cam members (68, 59) are arranged to be rotated at the same speed when moving in synchronism



and the relative configurations of said first and second cam members ensures engagement of the non-synchromesh coupling sleeve (37) first.

12. A selecting mechanism according to claim 10 or 11 when directly or indirectly dependent on claim 2 characterised in that the cam member (68) associated with the synchromesh sleeve (36b) has a cam formation (67) for engagement by a follower (69) connected with the synchromesh sleeve, the cam formation having three zones, a first zone (P) contacted by the follower during movement of the coupling member towards the synchronising position, a second zone (Q) contacted by the follower during synchronisation and a third zone (N) contacted by the follower after synchronisation has taken place and as the coupling member is moved towards the fully engaged position, the first, second and third zones being shaped so that a tangent (103) to the cam surface at the point of contact (M) with the follower during synchronisation makes a smaller angle (α) with the direction of movement (F) of the cam member than tangents (102) drawn to points of contact (L) with the first and third zones of the cam surface so that for a given selection force applied to the cam member a larger ratio engagement (FF) is applied to the follower during synchronisation than when the follower is in contact with the first and third zones.

13. A transmission ratio selecting mechanism including the disconnecting means of claim 1 and being constructed and arranged substantially as hereinbefore described with reference to and as shown in Figures 8 and 9 or 21 of the accompanying drawings.



AMENDED CLAIMS

(received by the International Bureau on 24 December 1980 (24.12.80))

1. A transmission ratio selecting mechanism including a ratio selector means, first and second ratio coupling members (36b, 37) movable to couple associated gear wheels (28, 29 : 31, 32) with first (30) and second (19) shafts respectively to select a number of ratios of an associated transmission, and linkage means (65, 63, 54, 61, 62, 59, 57, 60 : 65, 63, 64, 70, 71, 68, 67, 69) for moving the ratio coupling members in response to movement of the ratio selector means, the ratio selecting mechanism being characterised in that the linkage means includes disconnecting means (72, 73, 63, 64) for disconnecting one (37) of the ratio coupling members from the selector means during selection of at least one of the transmission ratios, the selecting mechanism being arranged so that for the selection of said at least one ratio both the gear coupling members (36b, 37) are initially moved axially of their respective shafts (30, 19) in synchronism in the same direction by the selector means so that one coupling member (37) couples one of the associated gear wheels (31, 32) with one (19) of the shafts thus completing the first part of the selection of said at least one ratio, the disconnecting means is then operated, and selection of said at least one ratio is completed by further movement of only the other (36b) coupling member axially of its respective shaft (30) in the opposite direction in response to further movement of the selector means to couple another of the associated gear wheels (28, 29) with the other shaft (30), the selector means being arranged to return the ratio coupling members to synchronism on movement of the selector means to select another ratio.

2. A selecting mechanism according to claim 1 characterised in that the linkage means includes a member (63) which is angularly movable in response to movements of the selector



means, first (68) and second (59) cam members being arranged to be moved by the angularly movable member to move said first (36b) and second (37) ratio coupling members respectively, and the disconnecting means (72, 73, 63, 64) is arranged to disconnect drive from the angularly movable member to one (59) of the cam members during selection of said at least one ratio.

3. A selecting mechanism according to claim 2 characterised in that the disconnecting means (72, 73, 63, 64) is arranged to displace the angularly movable member (63) in a direction generally parallel to its axis of angular movement to disconnect drive to said one cam member (59).

4. A selecting mechanism according to claim 3 characterised in that the disconnecting means includes a toggle linkage (72, 73) connected with the selector means for displacing the angularly movable member (63).

5. A selecting mechanism according to claim 3 or claim 4 characterised in that the angularly movable member comprises a shaft (63) with a splined portion (64) which engages first and second drive members (61, 70) for angularly displacing the first and second cam (68, 59) respectively, the disconnecting means (72, 73) being arranged to axially displace the shaft to disengage one (61) of the drive members from the splined portion (64).

6. A selecting mechanism according to claim 5 characterised in that the drive members each comprise a toothed sector (61, 70) which engages the splined portion (64) and gear teeth (62, 71) associated with each respective cam (59, 68)

7. A selecting mechanism according to any one of claims 2 to 6 characterised in that the cam members (59, 68) each



comprise a cylindrical member with a cam formation (57, 67) formed around its periphery, each formation being engaged by a cam follower (60, 69) arranged to move the associated coupling member (36b, 37).

8. A selecting mechanism according to claim 1 characterised in that the linkage means includes two generally parallel shift rails (143, 144) one for each ratio coupling member (36b, 37) and a selector member (135) connected with the ratio selector means (145), the ratio selector member having two formations (137, 138) engageable with co-operating formations (139, 140) associated with the two rails (143, 144), the formations on the selector member being movable in directions generally parallel to directions of extension of the rails to move said rails and also being movable during the selection of said at least one ratio in directions generally perpendicularly to said directions of extension in order to disconnect one (138) of the formations on the selector means from its co-operating rail formation (140) thus disconnecting the associated ratio coupling member (37) from the ratio selector means (145).

9. A selecting mechanism according to any one of claims 1 to 8 characterised in that the first ratio coupling member comprises a coupling sleeve (37) forming part of a non-synchromesh clutch unit and the second ratio coupling member comprises a coupling sleeve (36b) forming part of a synchromesh clutch unit of the type specified, the linkage means ensuring that the non-synchromesh coupling sleeve (37) is brought into engagement first during the selection of each ratio of the associated transmission.

10. A selecting mechanism according to claim 9 when directly or indirectly dependent on claim 2 characterised in that the first and second cam members (68, 59) are



arranged to be rotated at the same speed when moving in synchronism and the relative configurations of said first and second cam members ensures engagement of the non-synchromesh coupling sleeve (37) first.

11. A selecting mechanism according to claim 9 or 10 when directly or indirectly dependent on claim 2 characterised in that the cam member (68) associated with the synchromesh sleeve (36b) has a cam formation (67) for engagement by a follower (69) connected with the synchromesh sleeve, the cam formation having three zones, a first zone (P) contacted by the follower during movement of the coupling member towards the synchronising position, a second zone (Q) contacted by the follower during synchronisation and a third zone (N) contacted by the follower after synchronisation has taken place and as the coupling member is moved towards the fully engaged position, the first, second and third zones being shaped so that a tangent (103) to the cam surface at the point of contact (M) with the follower during synchronisation makes a smaller angle (α) with the direction of movement (F) of the cam member than tangents (102) drawn to points of contact (L) with the first and third zones of the cam surface so that for a given selection force applied to the cam member a larger ratio engagement (FF) is applied to the follower during synchronisation than when the follower is in contact with the first and third zones.

12. A transmission ratio selecting mechanism including the disconnecting means of claim 1 and being constructed and arranged substantially as hereinbefore described with reference to and as shown in Figures 8 and 9 or 21 of the accompanying drawings.



EDITORIAL NOTE

The claims amended by the applicant under Article 19 (1) of the PCT have not been re-numbered in accordance with Section 205 of the Administrative Instructions under the PCT.

The following information is given hereafter in order to facilitate the understanding of the claims:

Correspondence between original and amended claims:

<u>Original claims</u>	<u>Amended claims</u>
1	1 (amended)
2	2
3	3
4	4
5	5
6	6
7	7 (amended)
8	8
9 (cancelled)	
10	9 (amended)
11	10 (amended)
12	11 (amended)
13	12

1/20

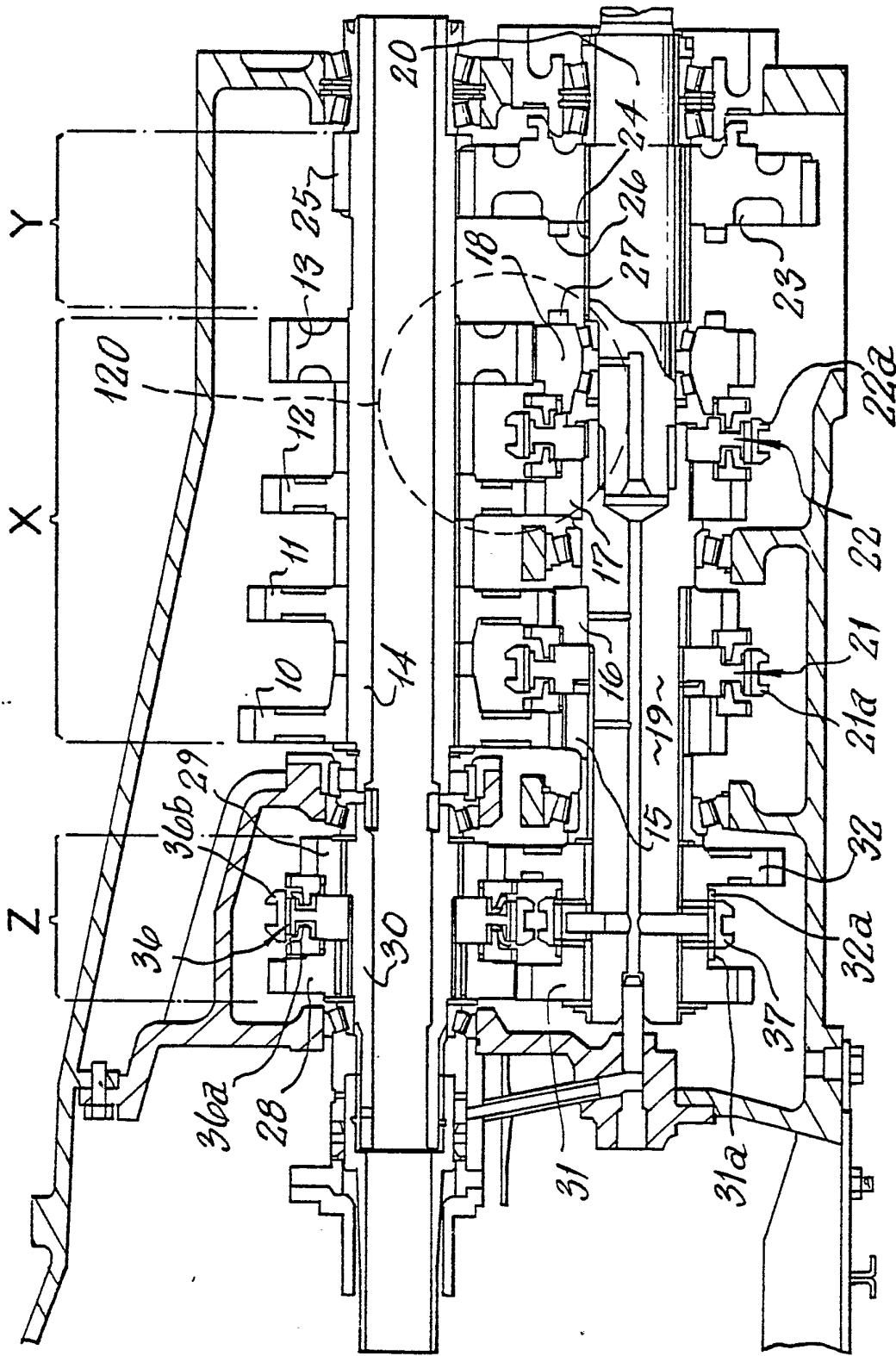

FIG. 1

2/20

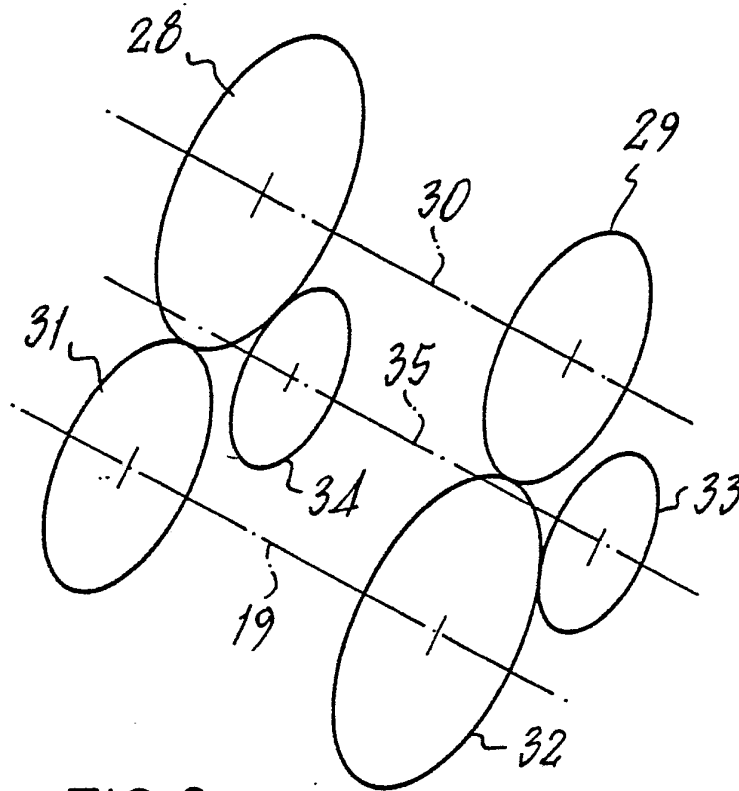

FIG.2

3/20

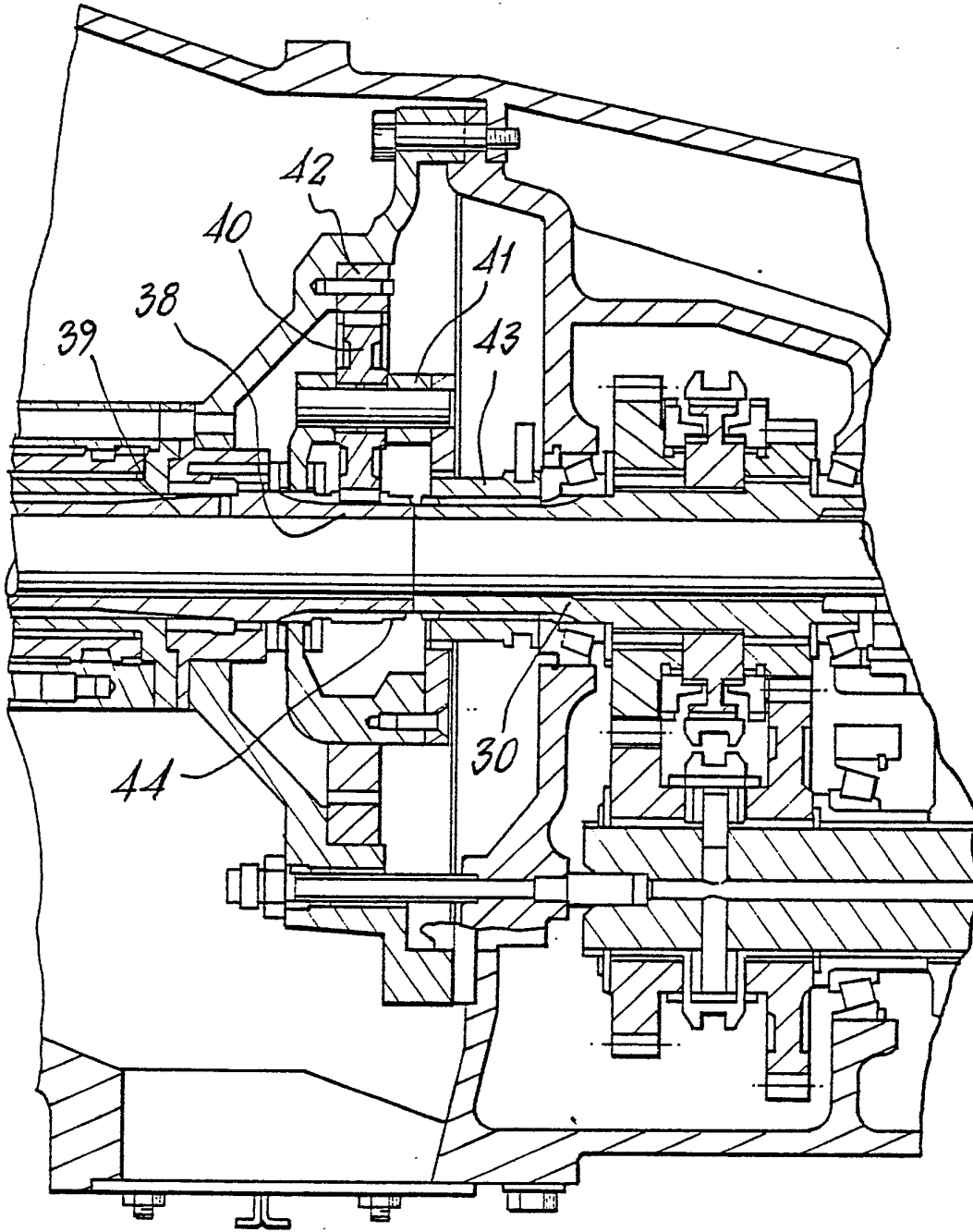

FIG. 3

4/20

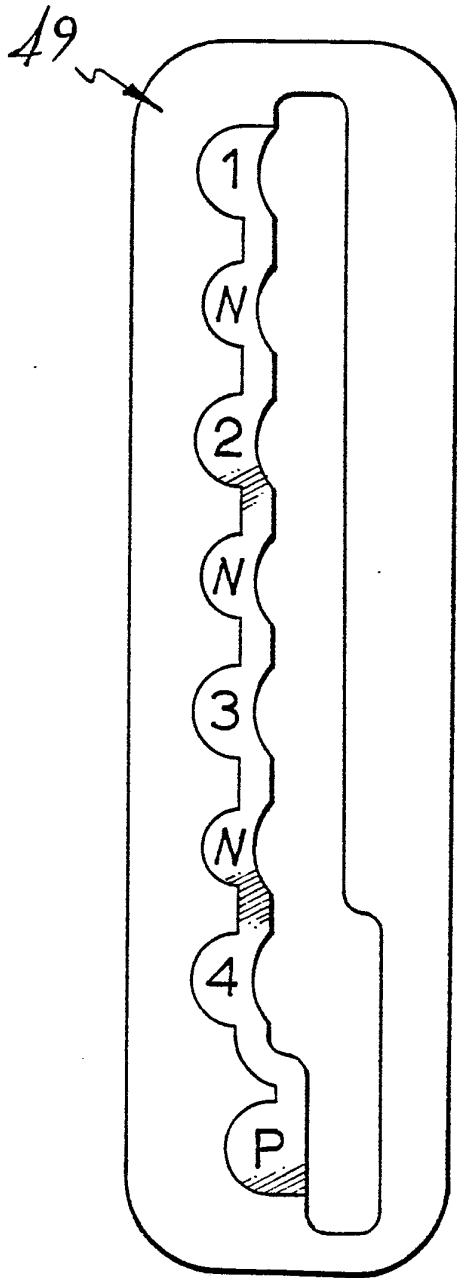

FIG. 4

5/20

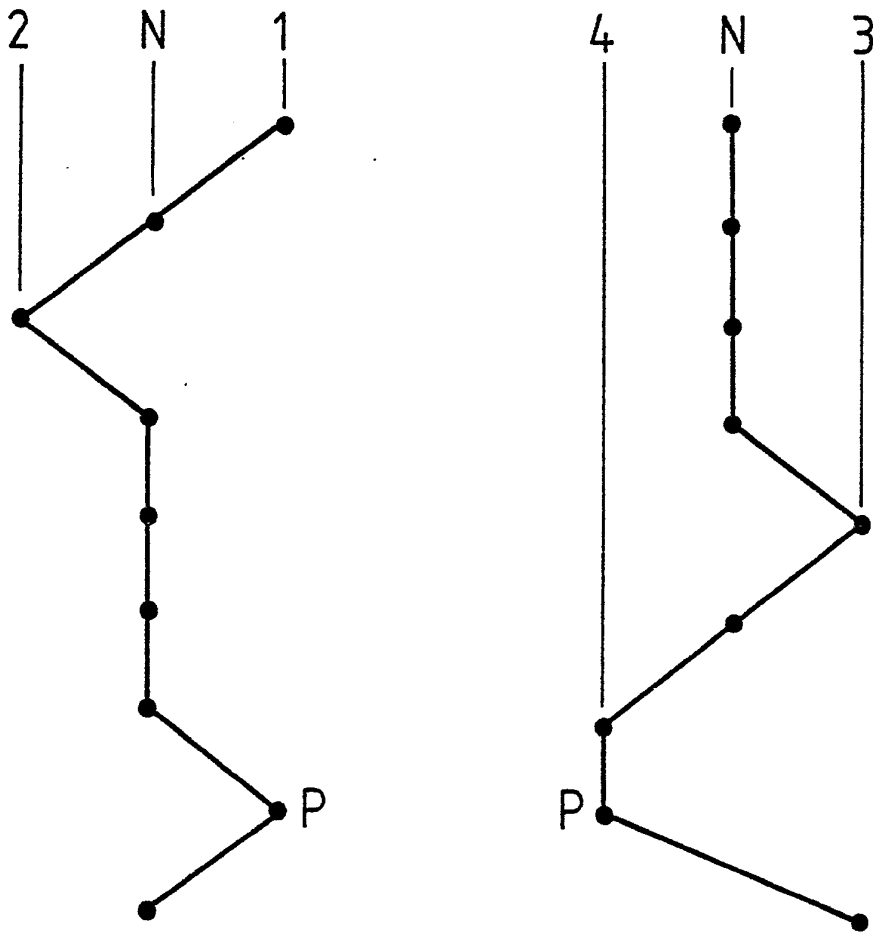

FIG.5

6120

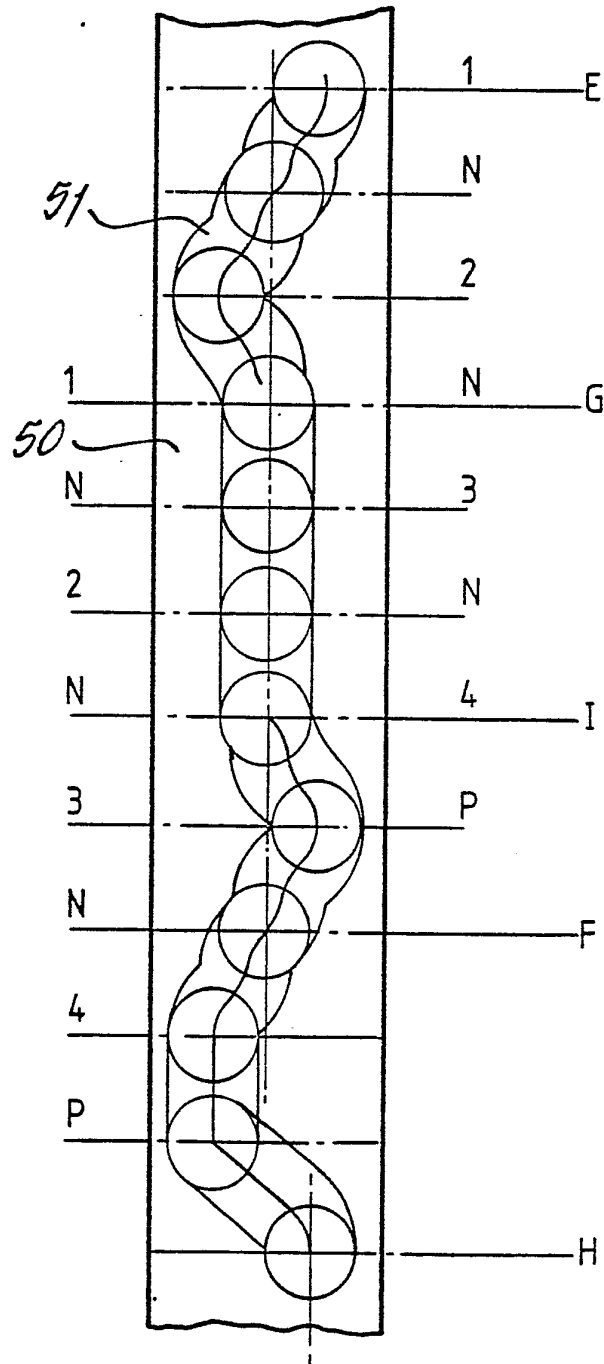

FIG. 6

7120

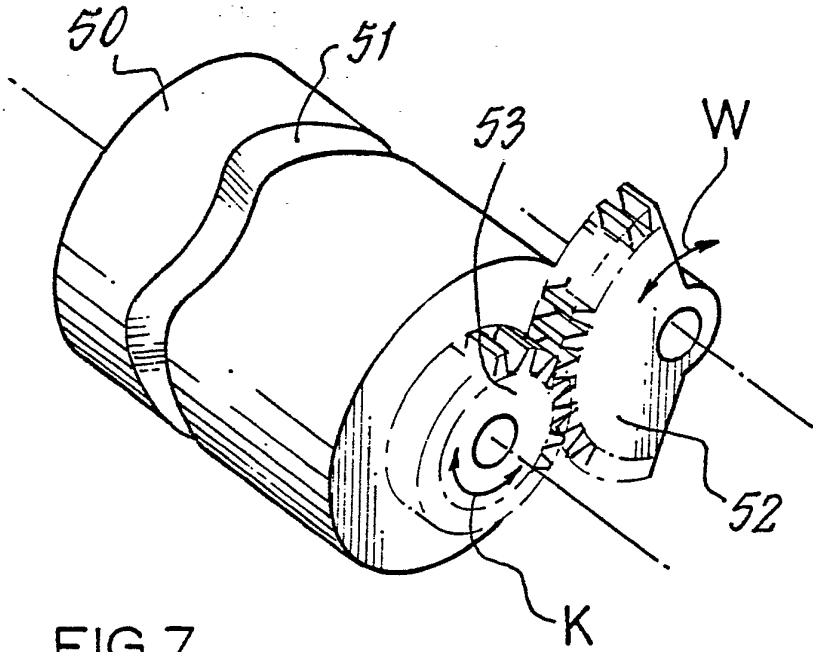

FIG. 7

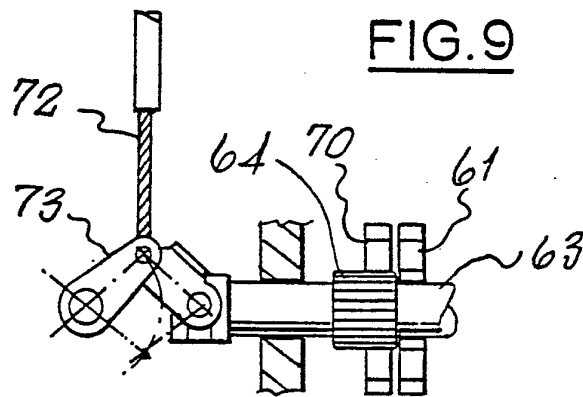

FIG. 9

8120

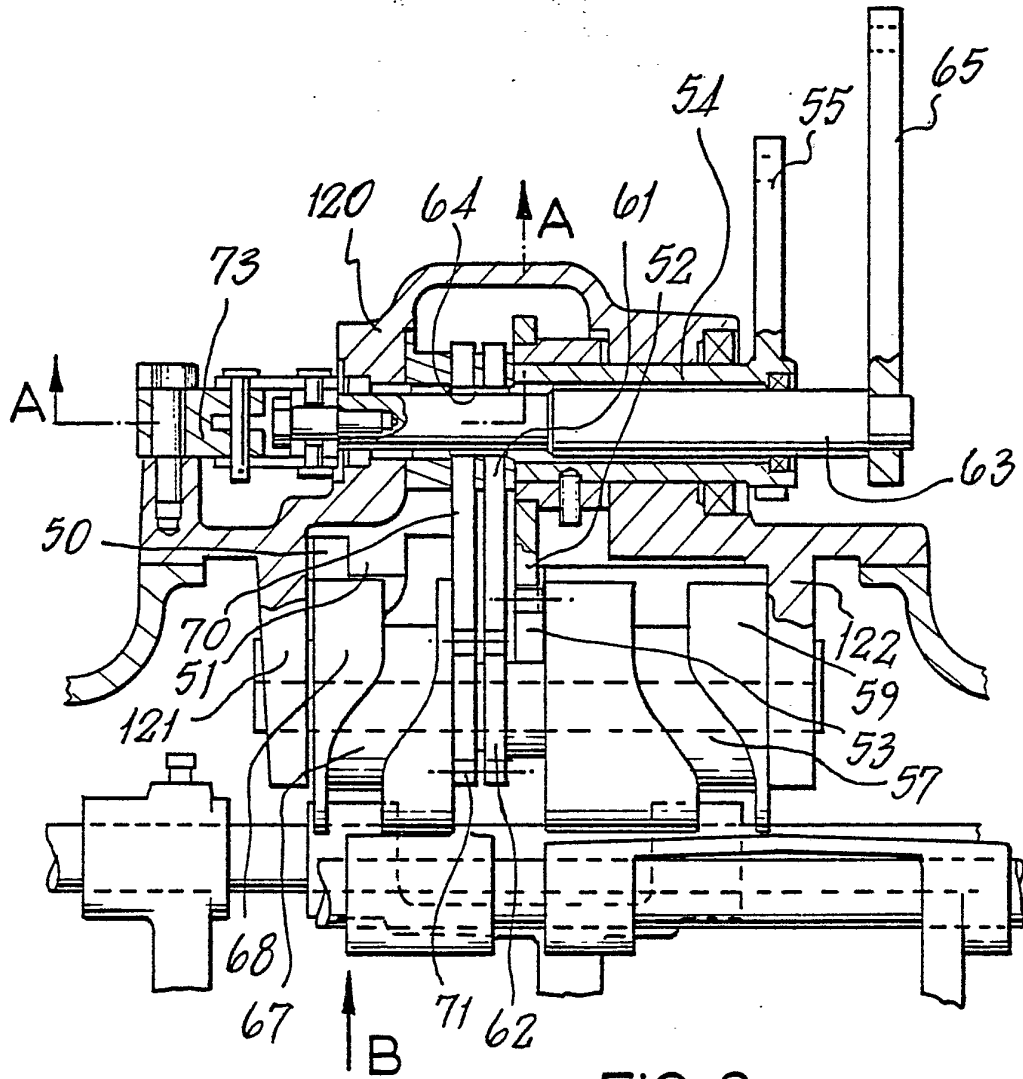

FIG. 8

9120

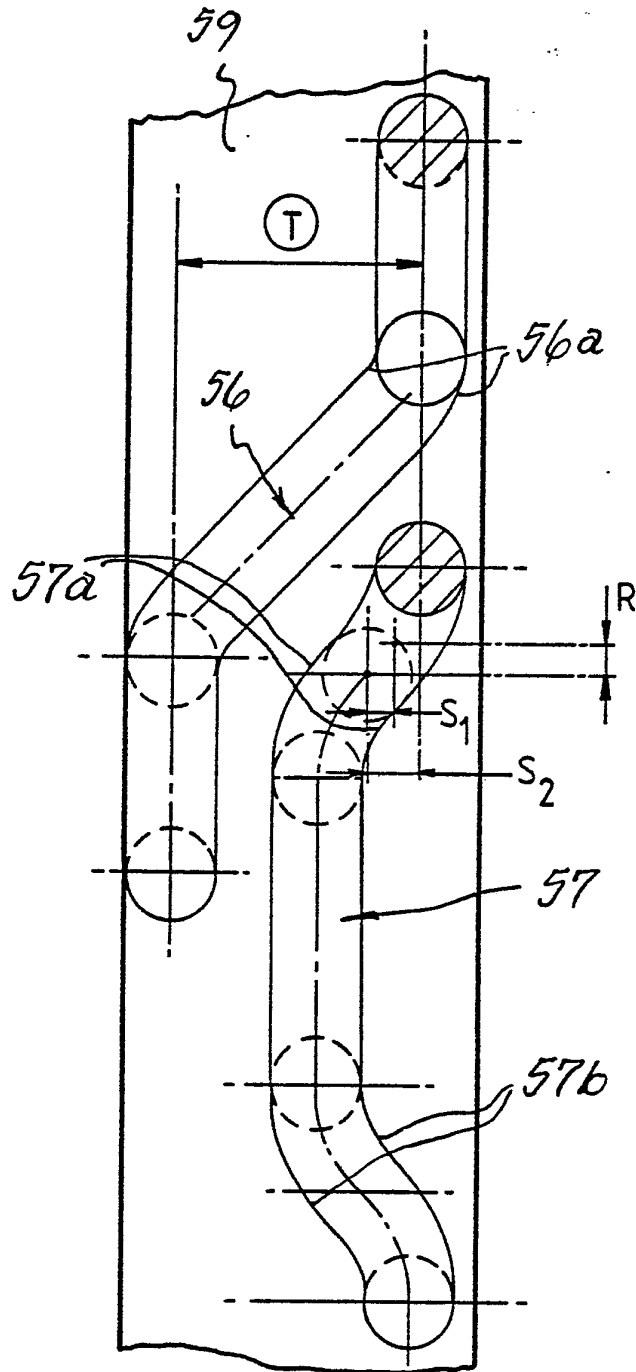

FIG. 10

10120

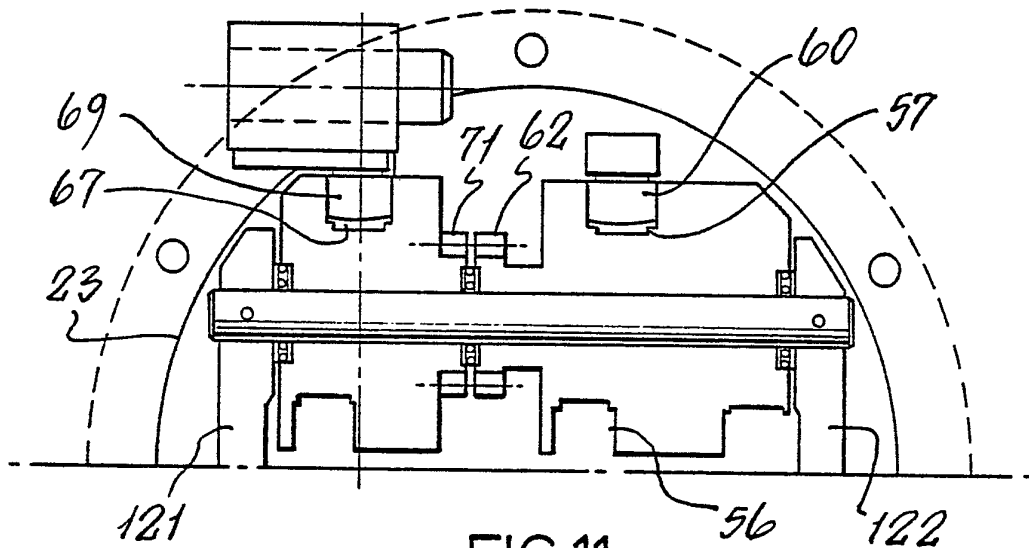

FIG.11

11/20

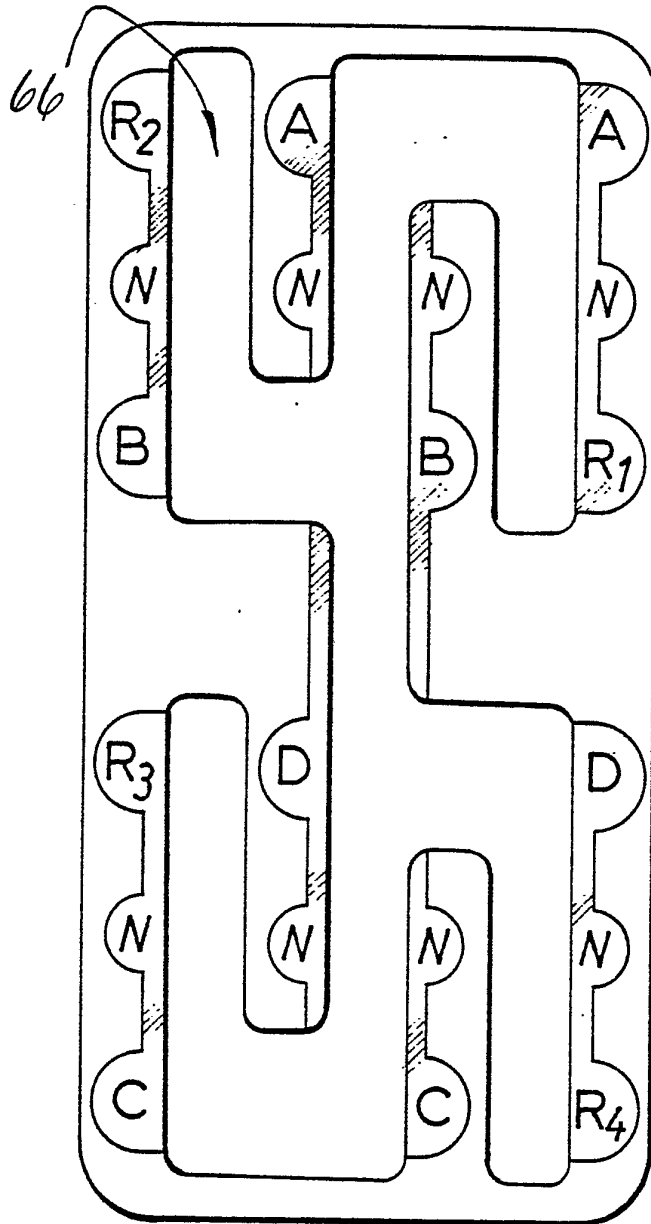

FIG. 12

12120

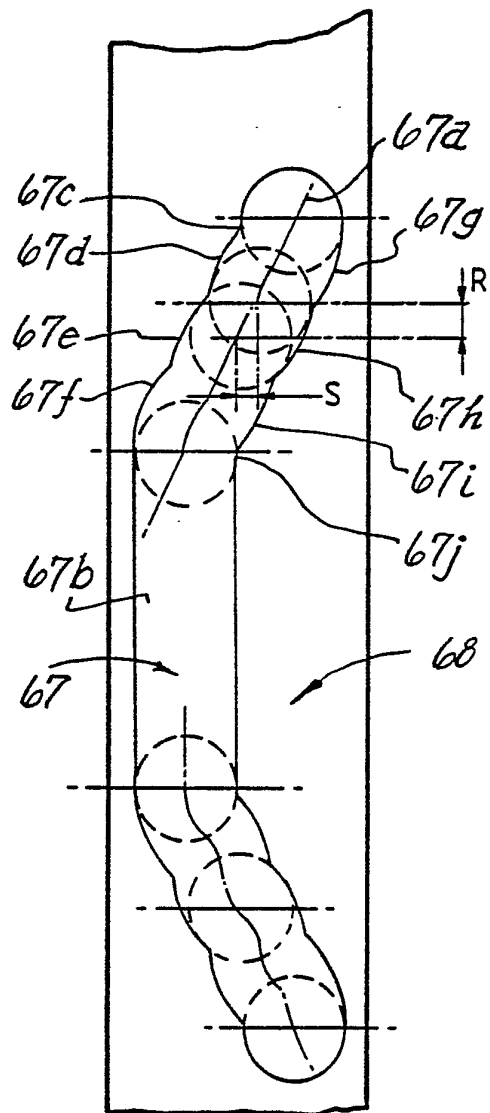

FIG.13

13/20

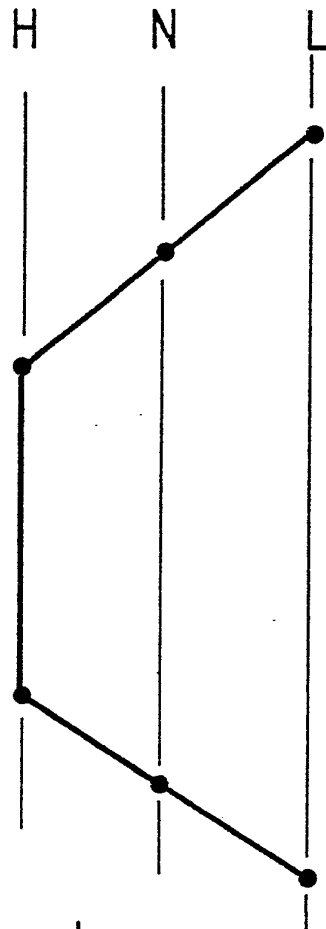

FIG. 14

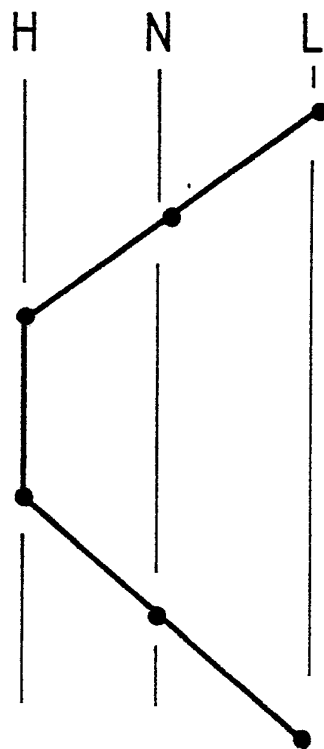
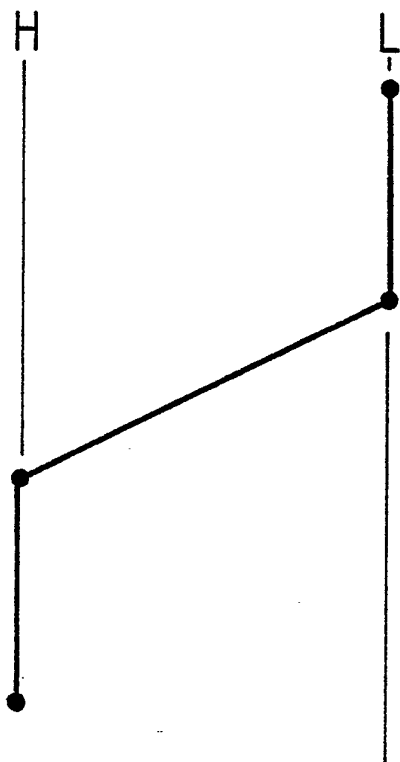

FIG. 16

14120

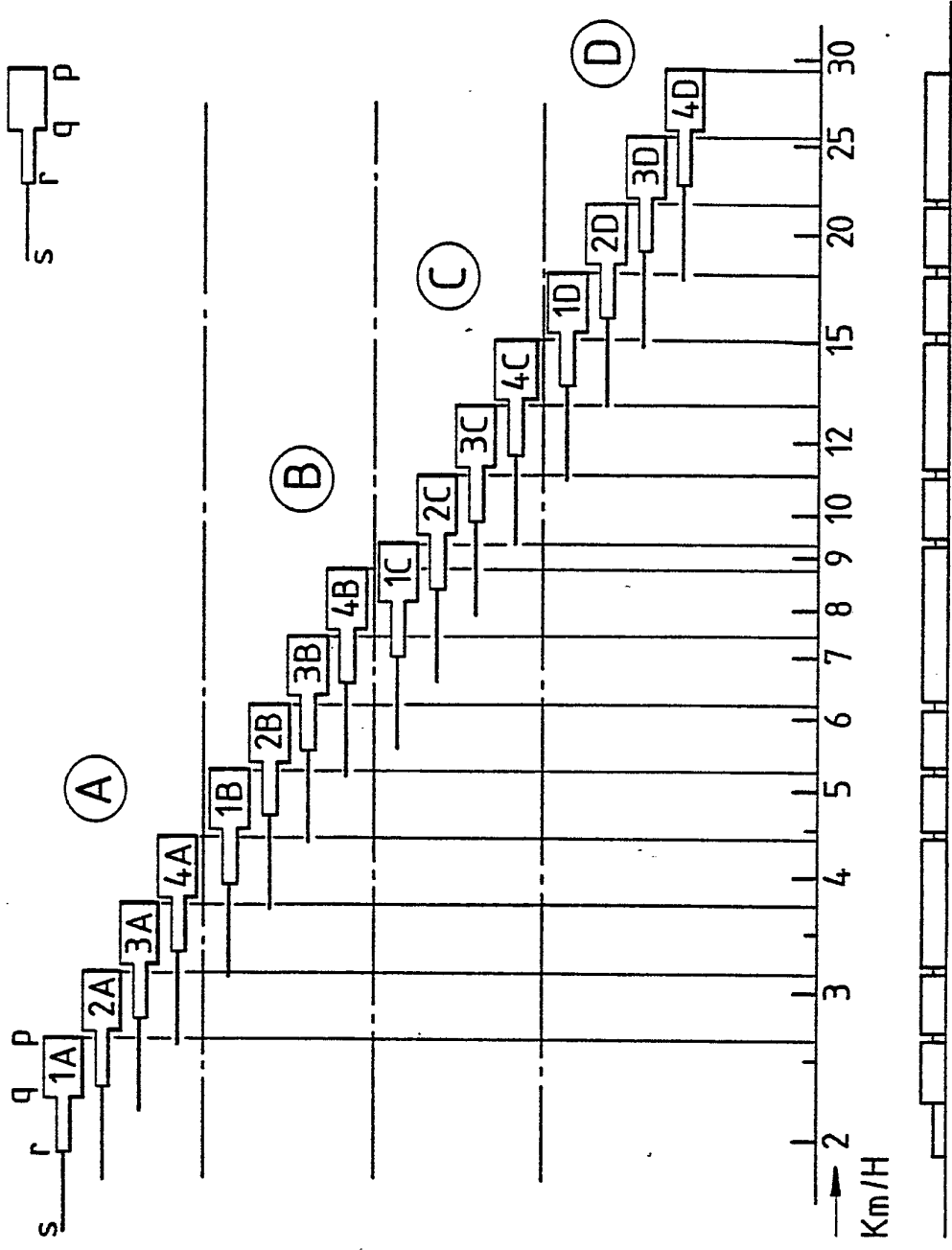

FIG.15

15/20

FORWARD RANGE	FORWARD RATIO No.	INPUT TRAIN Z GEARS USED BY REFERENCE No.		MAIN TRAIN X GEARS USED BY REFERENCE No.				OUTPUT TRAIN Y GEARS USED BY REFERENCE No.	
		29,32	28,31	10,15	11,16	12,17	13,18	23, 25	13,18,23
A	1	X		X				X	
	2	X			X			X	
	3	X				X		X	
	4	X					X	X	
B	5		X	X				X	
	6		X		X			X	
	7		X			X		X	
	8		X				X	X	
C	9	X		X					X
	10	X			X				X
	11	X				X			X
	12	X					X		X
D	13		X	X					X
	14		X		X				X
	15		X			X			X
	16		X				X		X

FIG. 17

16/20

REVERSE RANGE	REVERSE RATIO No.	INPUT TRAIN Z GEARS USED BY REFERENCE No.		MAIN TRAIN X GEARS USED BY REFERENCE No.				OUTPUT TRAIN Y GEARS USED BY REFERENCE No.	
		28 34 33 32	29,32,33, 34,28,31	10,15	11,16	12,17	13,18	23,25	13,18, 23
R ₁	1	X		X				X	
	2	X			X			X	
	3	X				X		X	
	4	X					X	X	
R ₂	5		X	X				X	
	6		X		X			X	
	7		X			X		X	
	8		X	-			X	X	
R ₃	9	X		X					X
	10	X			X				X
	11	X				X			X
	12	X					X		X
R ₄	13		X	X					X
	14		X		X				X
	15		X			X			X
	16		X				X		X

FIG. 18

18/20

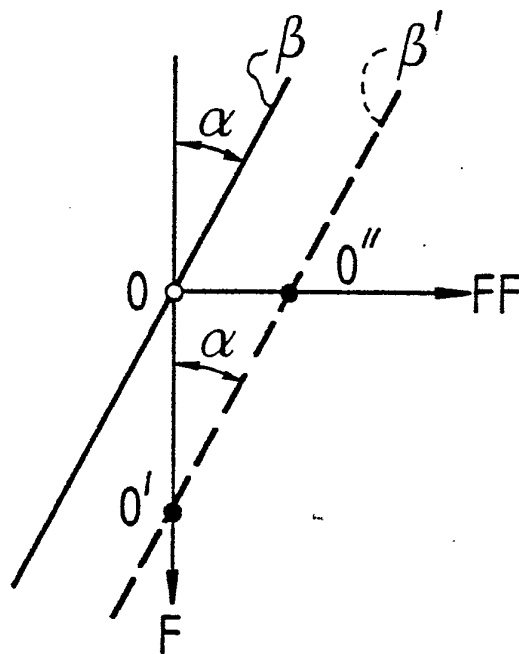

FIG.20

19120

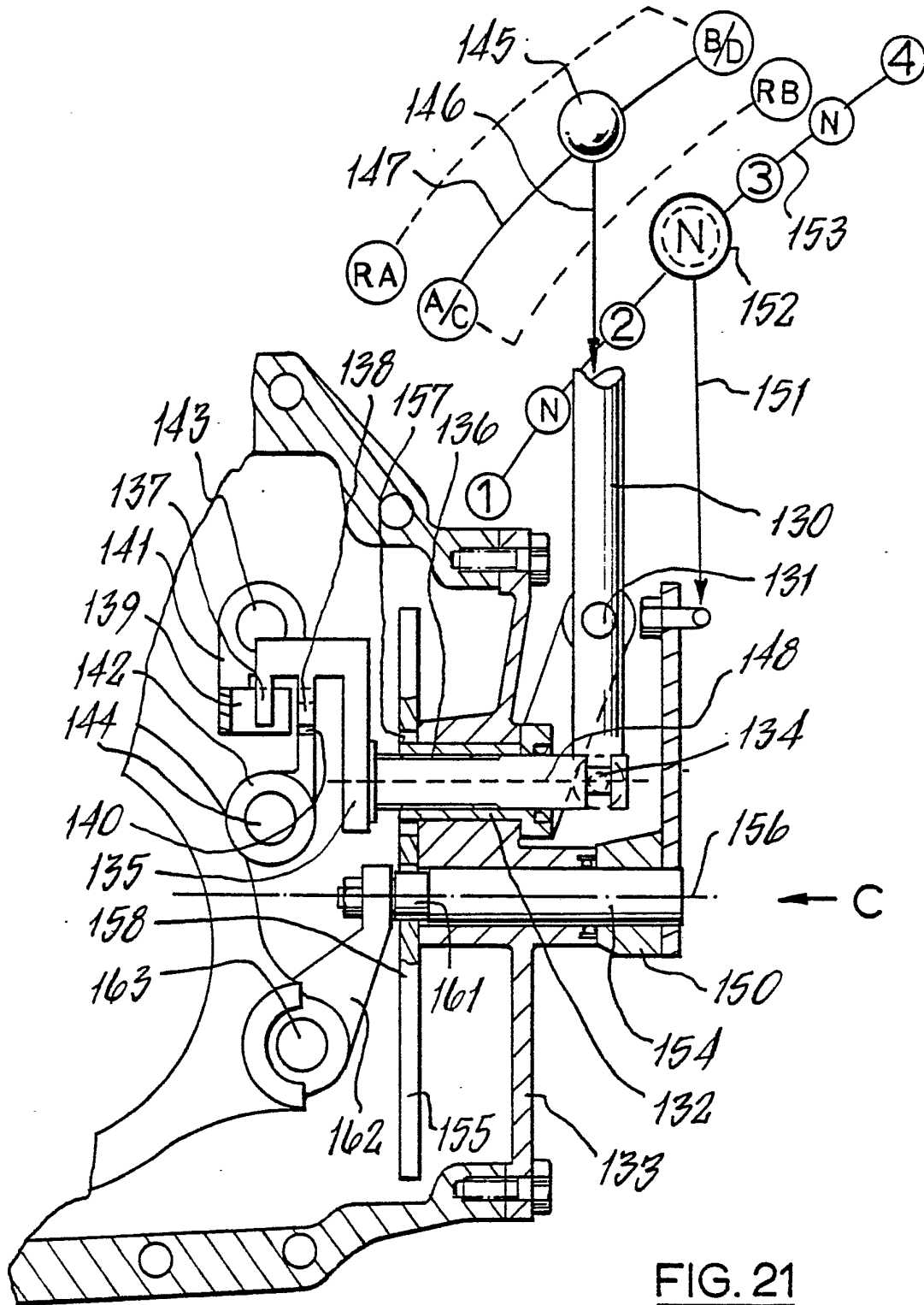

FIG. 21

20120

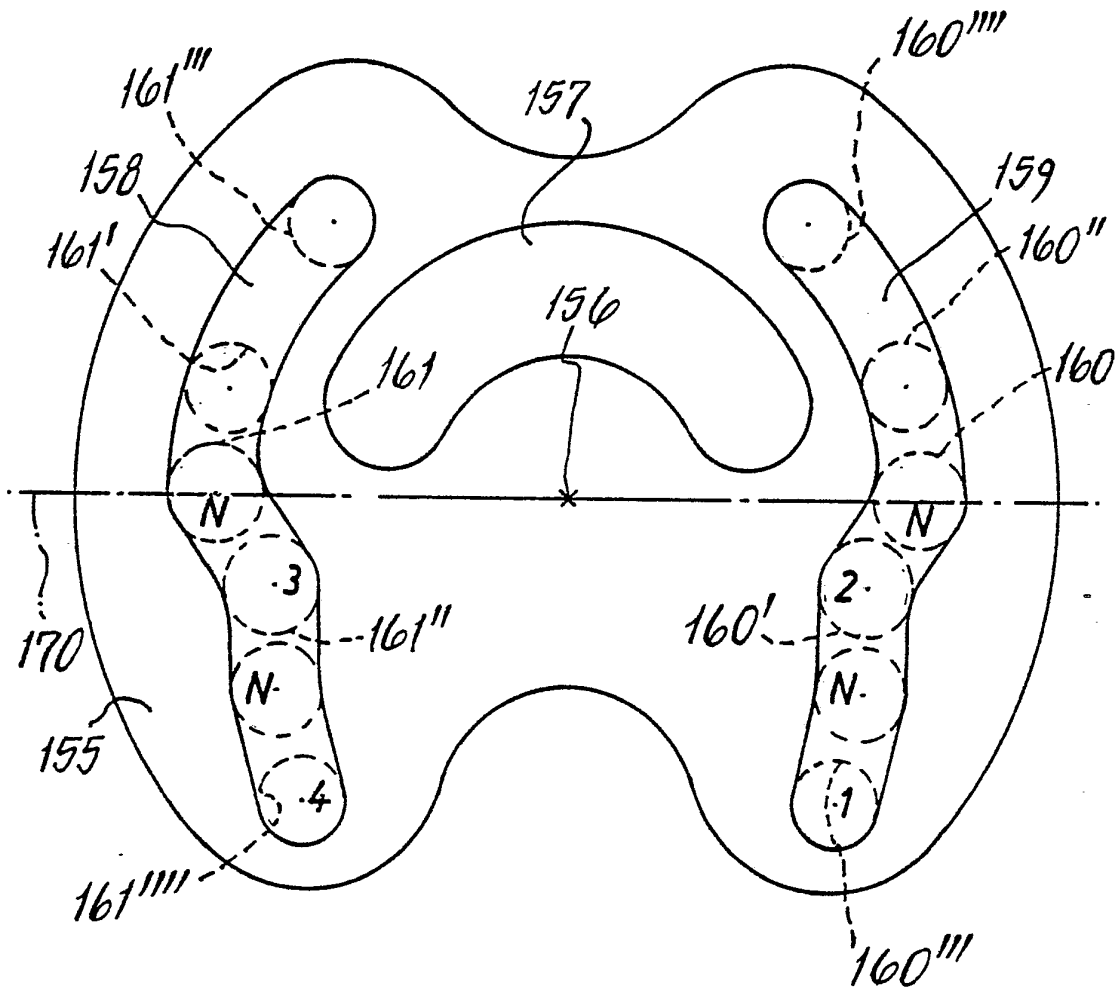

FIG.22

INTERNATIONAL SEARCH REPORT

International Application No PCT/EP 80/00054

I. CLASSIFICATION OF SUBJECT MATTER (if several classification symbols apply, indicate all) ³
 According to International Patent Classification (IPC) or to both National Classification and IPC

Int. Cl. ³: G 05 G 9/08; F 16 H 3/08

II. FIELDS SEARCHED

Minimum Documentation Searched ⁴

Classification System

Classification Symbols

Int. Cl. ³

F 16 H; G 05 G

Documentation Searched other than Minimum Documentation
to the extent that such Documents are Included in the Fields Searched ⁵

III. DOCUMENTS CONSIDERED TO BE RELEVANT ¹⁴

Category ¹⁵	Citation of Document, ¹⁶ with indication, where appropriate, of the relevant passages ¹⁷	Relevant to Claim No. ¹³
A	FR, A, 2299562, published August 27, 1976, see page 5, lines 1 to 18, Honda ---	1
A	US, A, 1716335, published April 23, 1927, see page 2, line 117 to page 3, line 35, figures 3 to 5, Ahlm ---	1
A	FR, A, 853448, published March 19, 1940, see the entire document, Zanosco ---	1
A	FR, A, 929534, published December 30, 1947, see the entire document, Gillet ---	1
A	FR, A, 470486, published September 12, 1914, see the entire document, Degory ---	1
A	FR, A, 794846, published February 26, 1936, see the entire document, Zurcher ---	1
A	GB, A, 346255, published April 30, 1931, see the entire document, Sturmey-Archer Gears Ltd. -----	1

* Special categories of cited documents: ¹⁵

"A" document defining the general state of the art

"E" earlier document but published on or after the international filing date

"L" document cited for special reason other than those referred to in the other categories

"O" document referring to an oral disclosure, use, exhibition or other means

"P" document published prior to the international filing date but on or after the priority date claimed

"T" later document published on or after the international filing date or priority date and not in conflict with the application, but cited to understand the principle or theory underlying the invention

"X" document of particular relevance

IV. CERTIFICATION

Date of the Actual Completion of the International Search ¹⁸

November 12, 1980

Date of Mailing of this International Search Report ¹⁹

November 21, 1980

International Searching Authority ¹

European Patent Office

Signature of Authorized Officer ²⁰

G.L.M. KRUYDENBERG *[Signature]*