

R. A. McEACHEN.

CABINET FOR THE SACRISTY.

APPLICATION FILED MAR. 5, 1908. RENEWED JUNE 14, 1909.

931,462.

Patented Aug. 17, 1909.

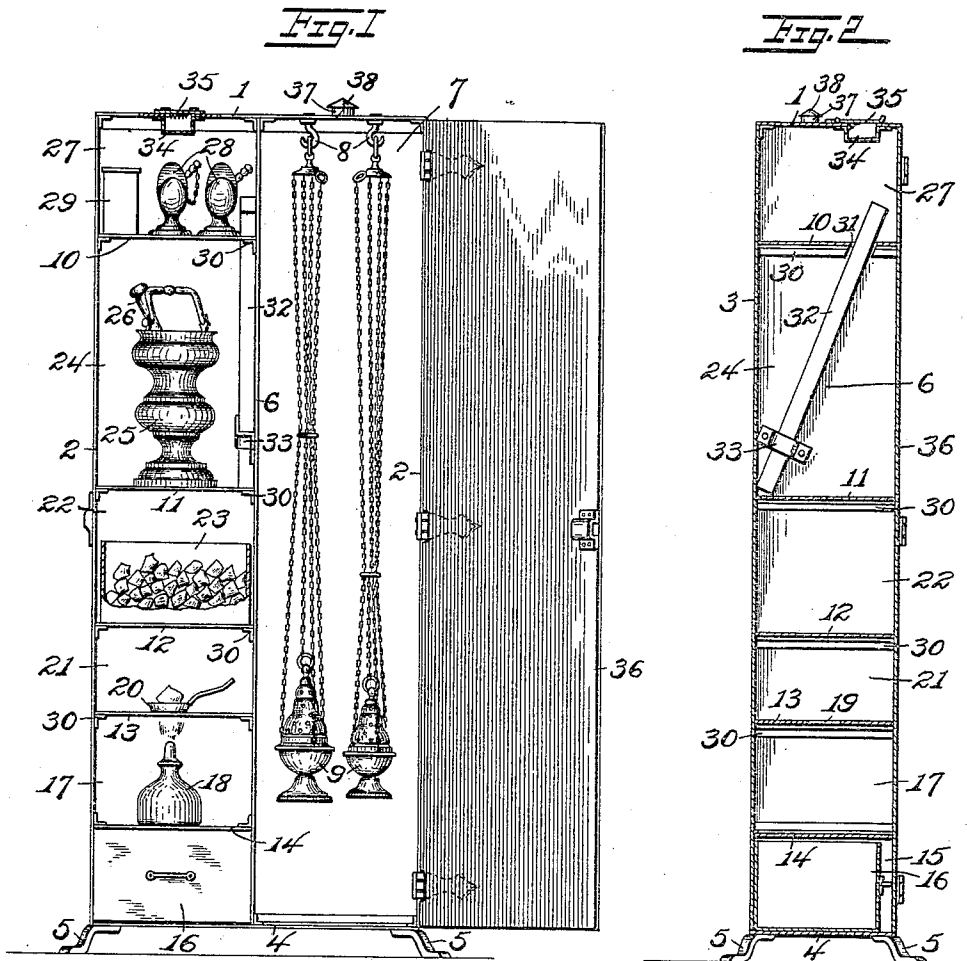

WITNESSES:
J. E. Arthur,
J. C. Gibson.

INVENTOR
Roderick A. McEachen.
BY
A. E. Dunlop.
ATTORNEY.

UNITED STATES PATENT OFFICE.

RODERICK A. McEACHEN, OF BARTON, OHIO.

CABINET FOR THE SACRISTY.

No. 931,462.

Specification of Letters Patent.

Patented Aug. 17, 1909.

Application filed March 5, 1908, Serial No. 419,397. Renewed June 14, 1909. Serial No. 502,134.

To all whom it may concern:

Be it known that I, RODERICK A. McEACHEN, a citizen of the United States of America, and resident of Barton, county of Belmont, and State of Ohio, have invented certain new and useful Improvements in Cabinets for the Sacristy, of which the following is a specification.

This invention relates to a fire-protection cabinet designed for the sacristy.

The primary object of the invention is to provide a comparatively simple and inexpensive fire-protection cabinet which is adapted for serving as a receptacle for certain accessories employed in the ritual of the Roman Catholic church.

A further object is to provide a receptacle of the character mentioned which is particularly adapted for the purpose for which it is designed, inasmuch as its arrangement is most convenient.

The novelty of the invention resides in certain improvements the exact nature of which will hereinafter appear, reference being had to the accompanying drawing, forming a part of this specification, in which—

Figure 1 is a front elevation of the cabinet, with its door open, showing the interior arrangement, and—Fig. 2 is a vertical sectional view of the same.

Referring to said drawing, in which like reference characters designate like parts throughout the several views—1 indicates the top, 2 the sides, 3 the rear wall, and 4 the bottom of a rectangular cabinet, preferably composed wholly of sheet metal, said cabinet having supporting legs 5 and having its interior centrally divided by a vertical partition-wall 6. A compartment 7 is formed at one side of said partition-wall, which compartment extends from the top 1 to the bottom 4, and rigidly attached to the top on the under side thereof and within said compartment are supporting-hooks 8 which are adapted for having censers 9 suspended therefrom. The opposite side of the cabinet is divided into a plurality of superposed compartments by shelves 10, 11, 12, 13 and 14, said compartments being of varying heights to suit the character of the various articles which are to be contained therein. The lower compartment 15 has removably mounted therein a tray or pan 16 for containing ashes, while the compartment 17 next thereabove is adapted for containing a spirit-lamp 18. An aperture 19 provided

in the shelf 13 admits the flame from the lighted lamp to a charcoal-holder or lighter 20 located over said aperture within the compartment 21. The compartment 22 next above is adapted for containing a supply of charcoal, or a receptacle 23 for same. The next above compartment 24 is relatively higher than those before described and is adapted for containing a holy-water pot 25 and sprinkler 26, and the uppermost compartment 27 is adapted for containing censers 28, incense 29, etc. The shelves are preferably removable, being mounted on angle-iron cleats 30 secured to the face of the partition-wall 6 and the side-wall 2.

The upper shelf 10 has a slot therein at the end thereof adjacent to the partition-wall 6, and the under-lying cleat 30 attached to said partition-wall is cut away, an aperture 31 being thus formed in which is held the upper end of a box 32 for containing wax tapers, while the lower end of said box rests upon the shelf 11 adjacent to the rear wall 3. A keeper 33 fixed to the partition-wall 6 in an inclined position serves to hold the box 32 close against said partition-wall. The aperture 31 and keeper 33 are so located with respect to each other and to the junction of the shelf 11 and rear wall 3 that the box 32 is held in a forwardly-inclined position which readily admits of the withdrawal of tapers therefrom without interference from the top 1.

On the under side of the top 1 is a match-receptacle 34, and a spring-closed lid 35 closes an aperture in said top through which access is had to said box.

A hinged metal door 36 is provided on the front of the cabinet.

In the top of the cabinet is a flue 37 through which products of combustion from any of the compartments escape to the atmosphere, and a hood 38 is supported over the top of said flue whereby extraneous or foreign matter is prevented from entering the cabinet.

Having thus described my invention, what I claim as new, and desire to secure by Letters Patent, is—

1. A cabinet for the sacristy comprising a casing, a vertical partition-wall dividing said casing into two sides, shelves dividing one of said sides into a plurality of compartments, an inclined keeper carried by said partition-wall in one of said compartments, and a slot in the shelf next above said keeper at the end

adjacent to said partition-wall, said keeper and said slot being so arranged with respect to each other and the next shelf therebelow that a taper-box mounted therein is held in a forwardly-inclined position close against said partition-wall.

2. A cabinet for the sacristy comprising a casing, a vertical partition-wall dividing said casing into two sides, shelves dividing one of said sides into a plurality of compartments, an inclined keeper carried by said partition-wall in one of said compartments, a slot in the shelf next above said keeper at the end adjacent to said partition-wall, said keeper and said slot being so arranged with respect to each other and the next shelf therebelow that a taper-box mounted therein with its lower end upon the last-mentioned shelf is held in a forwardly-inclined position against said partition-wall, and censer-supporting hooks carried on the under side of the top of the casing at the opposite side of said partition-wall.

3. A cabinet for the sacristy comprising a casing, a vertical partition-wall dividing said casing into two sides, shelves dividing one of said sides into a plurality of compartments, one of said shelves having an aperture therein for admitting of the passage of heat from a lighted spirit-lamp contained in the next compartment therebelow for igniting a superposed charcoal-block, an inclined keeper carried by said partition-wall in one of said compartments, and a slot in the shelf next above said keeper at the end adjacent

to said partition-wall, said keeper and said slot being so arranged with respect to each other and to the next shelf therebelow that a taper-box mounted therein is held in a forwardly-inclined position against said partition-wall.

4. A cabinet for the sacristy comprising a casing, a vertical partition-wall dividing said casing into two sides, shelves dividing one of said sides into a plurality of compartments, one of said shelves having an aperture therein for admitting of the passage of heat from a lighted spirit-lamp contained in the next compartment therebelow for igniting a superposed charcoal-block, an inclined keeper carried by said partition-wall in one of said compartments, and a slot in the shelf next above said keeper at the end adjacent to said partition-wall, said keeper and said slot being so arranged with respect to each other and to the next shelf therebelow that a taper-box mounted therein is held in a forwardly-inclined position against said partition-wall, a match-receptacle on the under side of the top of the casing, said top having an aperture therein through which access is had to said receptacle, and a spring-closed lid covering said aperture.

In testimony whereof I affix my signature in presence of two subscribing witnesses.

RODERICK A. McEACHEN.

Witnesses:

H. E. DUNLAP,
J. C. GIBSON.