

[54] REMOTE-CONTROLLED CIRCUIT BREAKER

[75] Inventors: Hirotohi Ohishi; Tatunori Ikeda; Manabu Sogabe, all of Fukuyama, Japan

[73] Assignee: Mitsubishi Denki Kabushiki Kaisha, Tokyo, Japan

[21] Appl. No.: 416,660

[22] Filed: Oct. 3, 1989

[30] Foreign Application Priority Data

Oct. 6, 1988 [JP]	Japan	63-131088[U]
Oct. 6, 1988 [JP]	Japan	63-131090[U]
Oct. 6, 1988 [JP]	Japan	63-131091[U]
Jul. 25, 1989 [JP]	Japan	1-193545

[51] Int. Cl.⁵ H01H 75/00

[52] U.S. Cl. 335/14; 335/6; 335/20

[58] Field of Search 335/6, 16, 14, 20, 17

[56] References Cited

U.S. PATENT DOCUMENTS

4,855,698	8/1989	Cohen et al.	335/14
4,897,625	1/1990	Yokoyama et al.	335/14

Primary Examiner—Benjamin R. Fuller
Assistant Examiner—Lincoln Donovan
Attorney, Agent, or Firm—Burns, Doane, Swecker & Mathis

[57] ABSTRACT

A remote-controlled circuit breaker has an operation mechanism unit, for selected one of an off state and a remote-controllable state of the circuit breaker, and a movable contact which makes/breaks contact with a fixed contact in connection with a motion of an electromagnetic unit only in the remote-controllable state; and the movable contact breaks contact with the fixed contact irrespective of the motion of the electromagnetic unit at the time when an overcurrent tripping unit is operated by a fault. A push rods acts in conjunction with a transmission lever to either provide an indication of the state of contact connection or to actuate tripping. An indication mechanism is also disclosed.

8 Claims, 25 Drawing Sheets

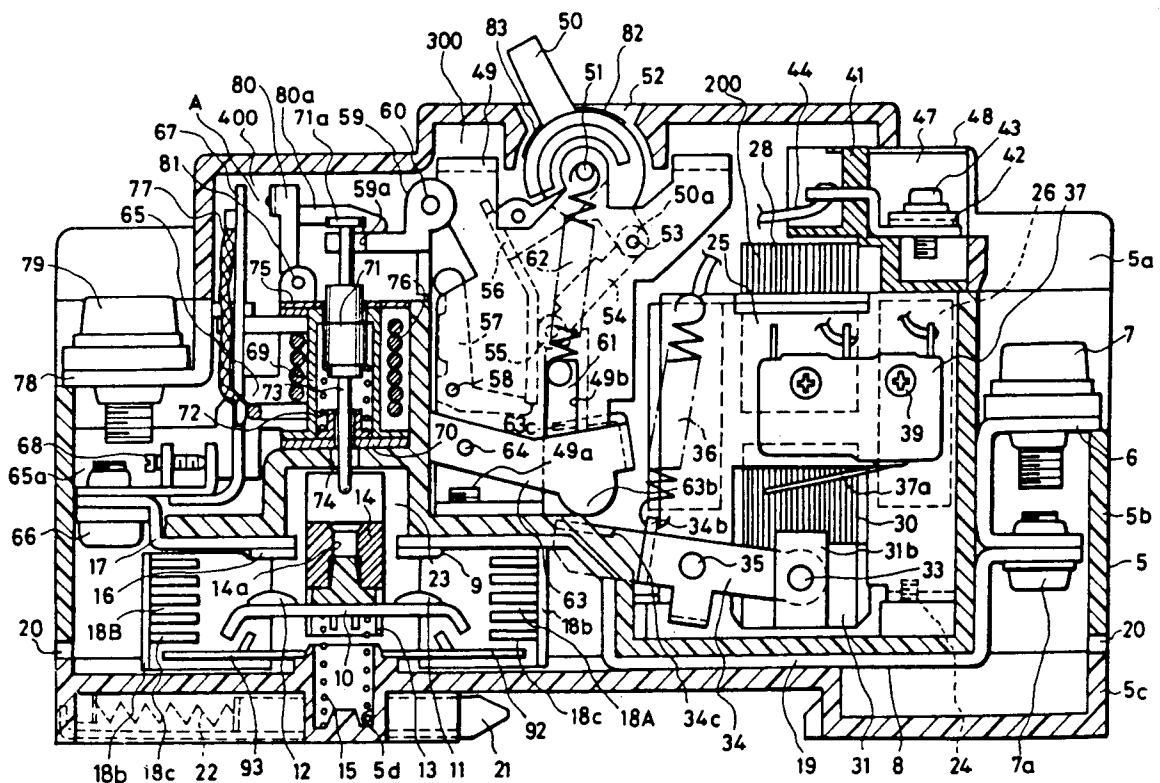
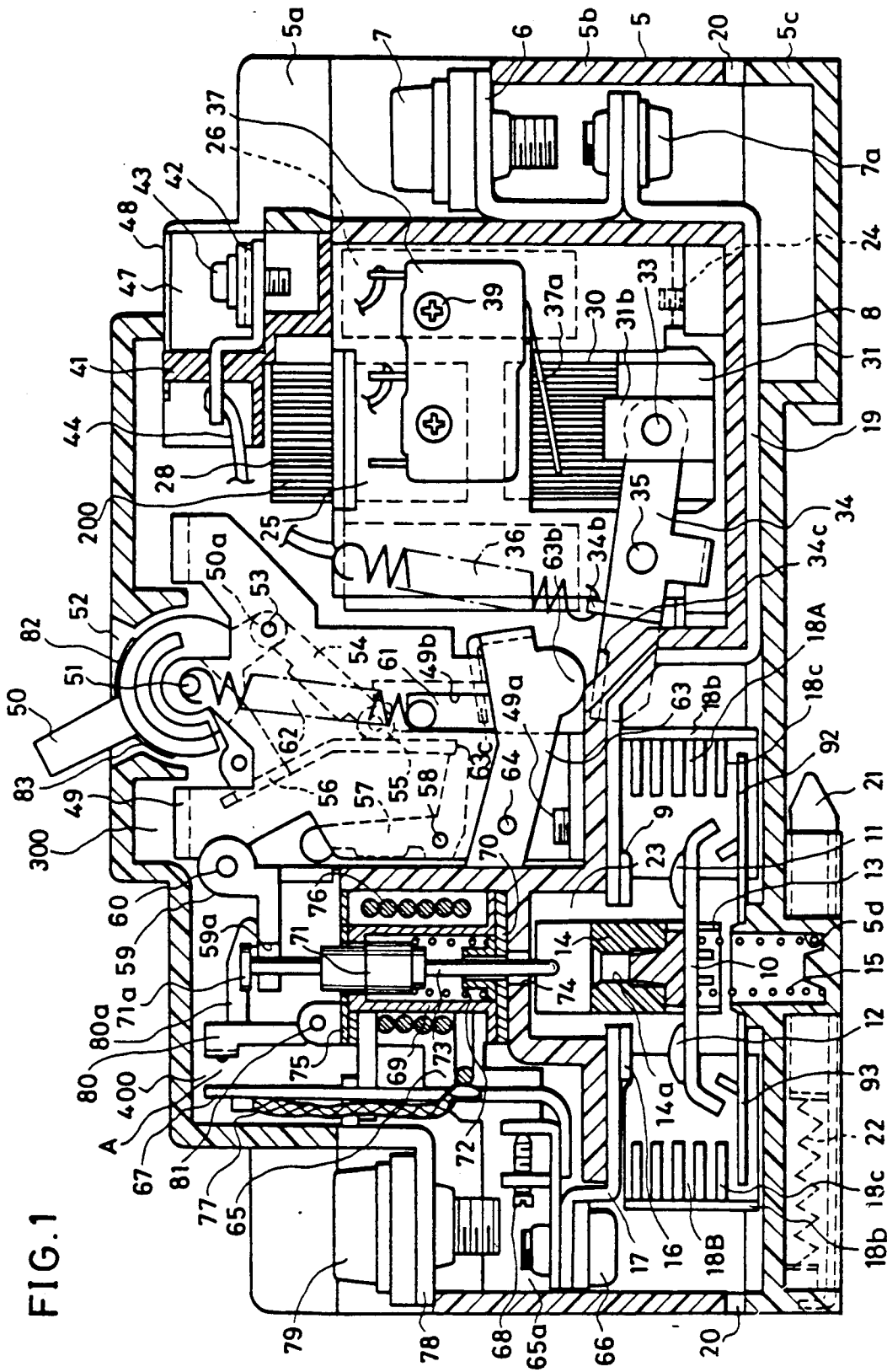
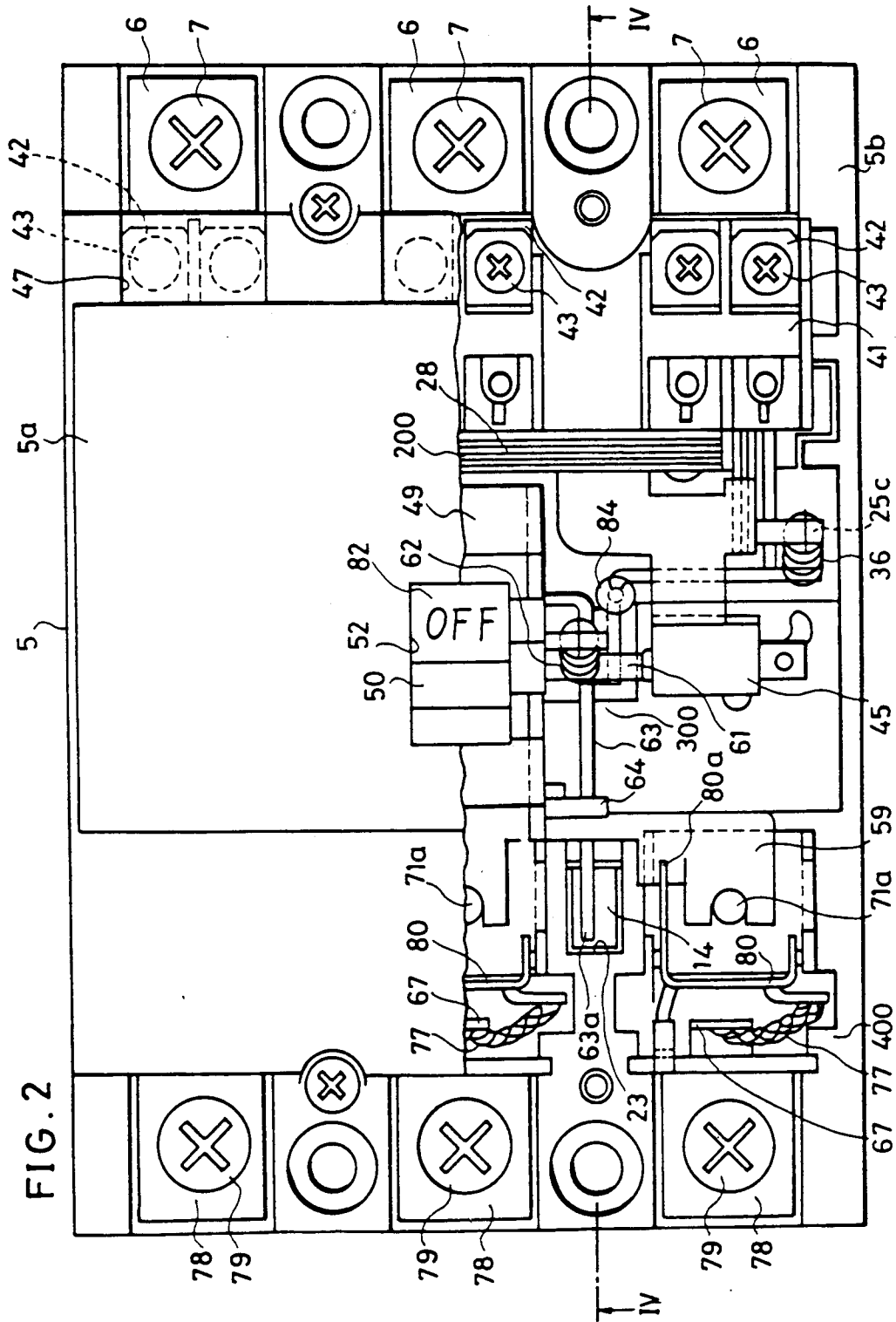

FIG. 1





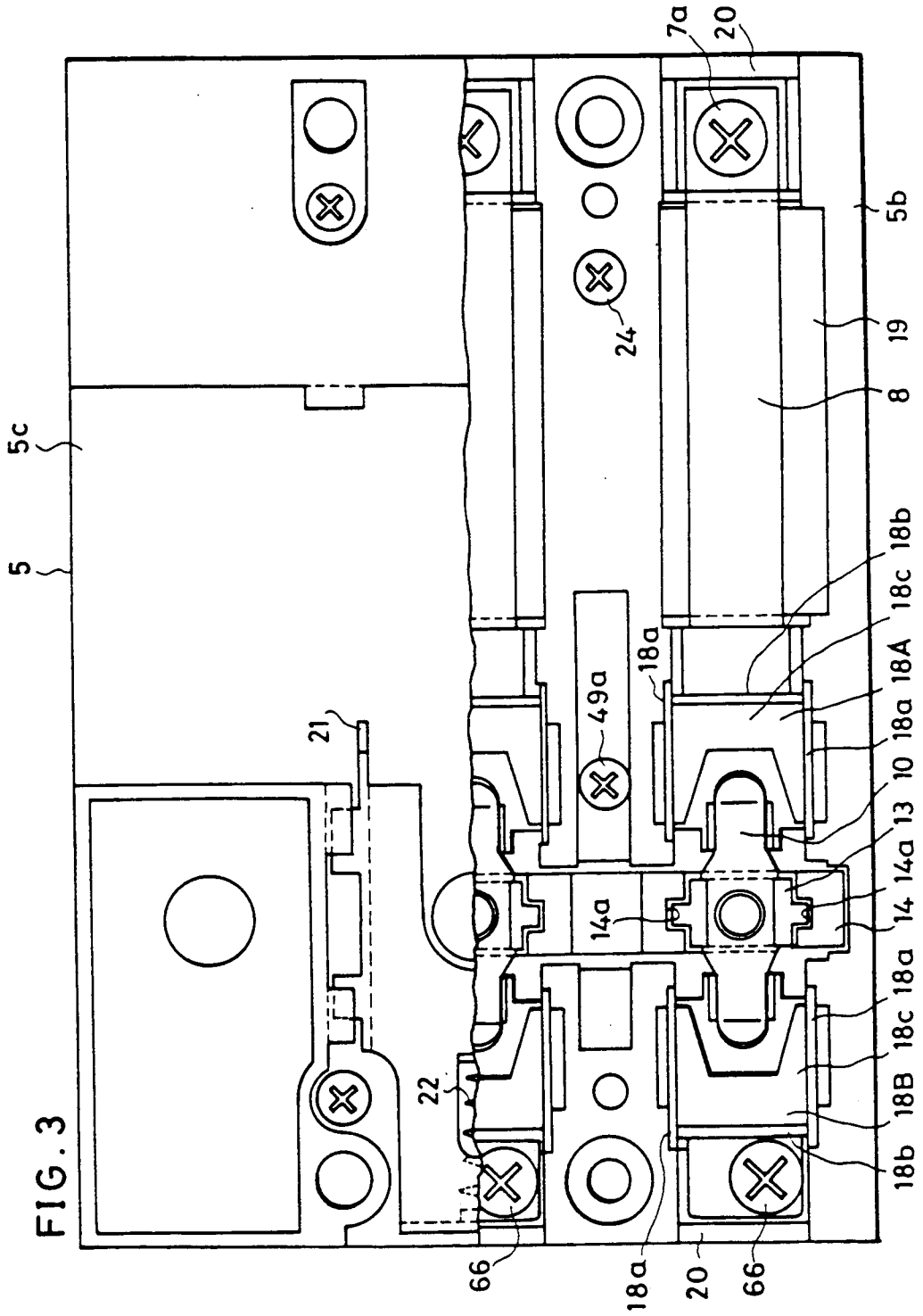

FIG. 4

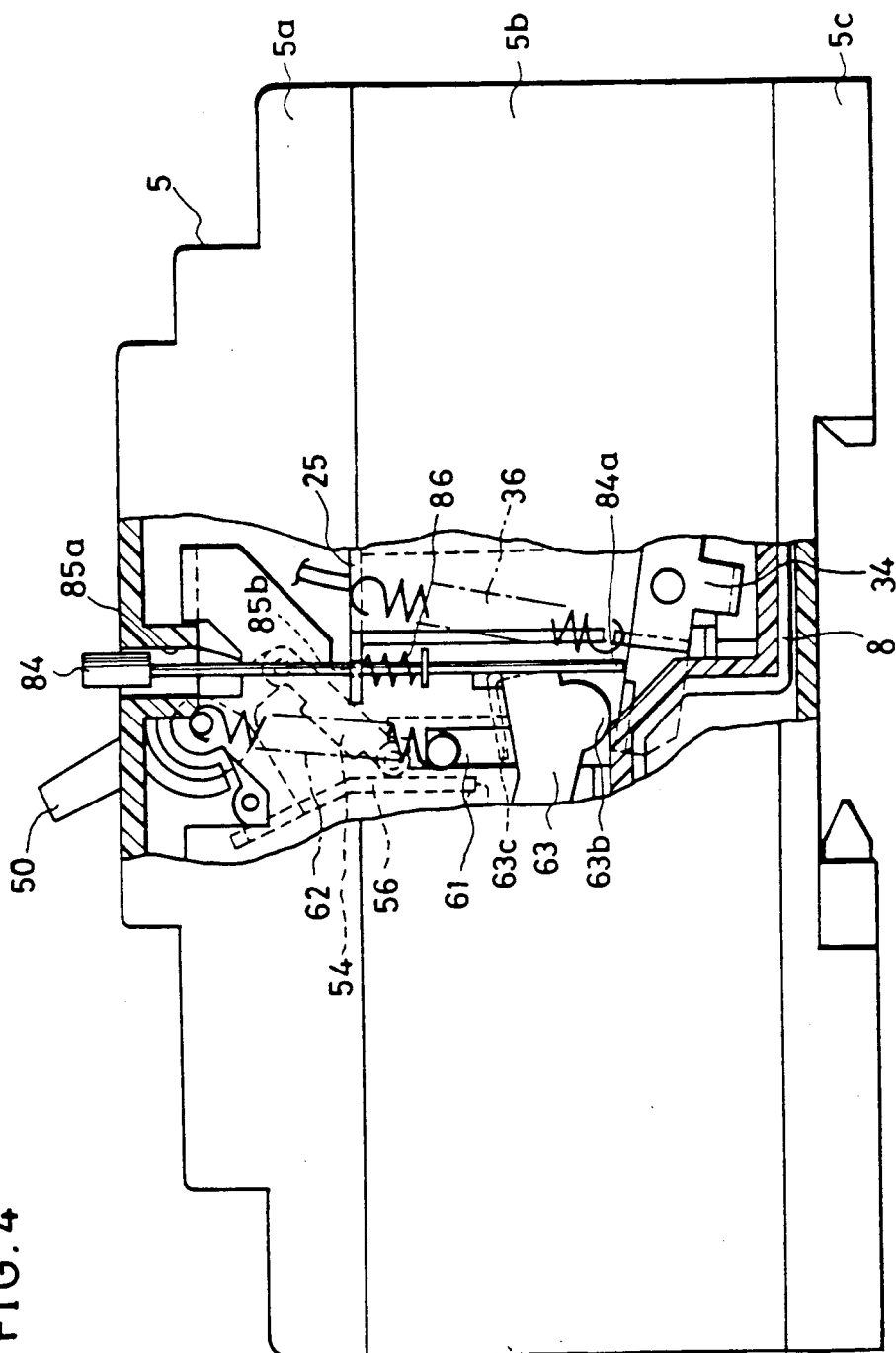
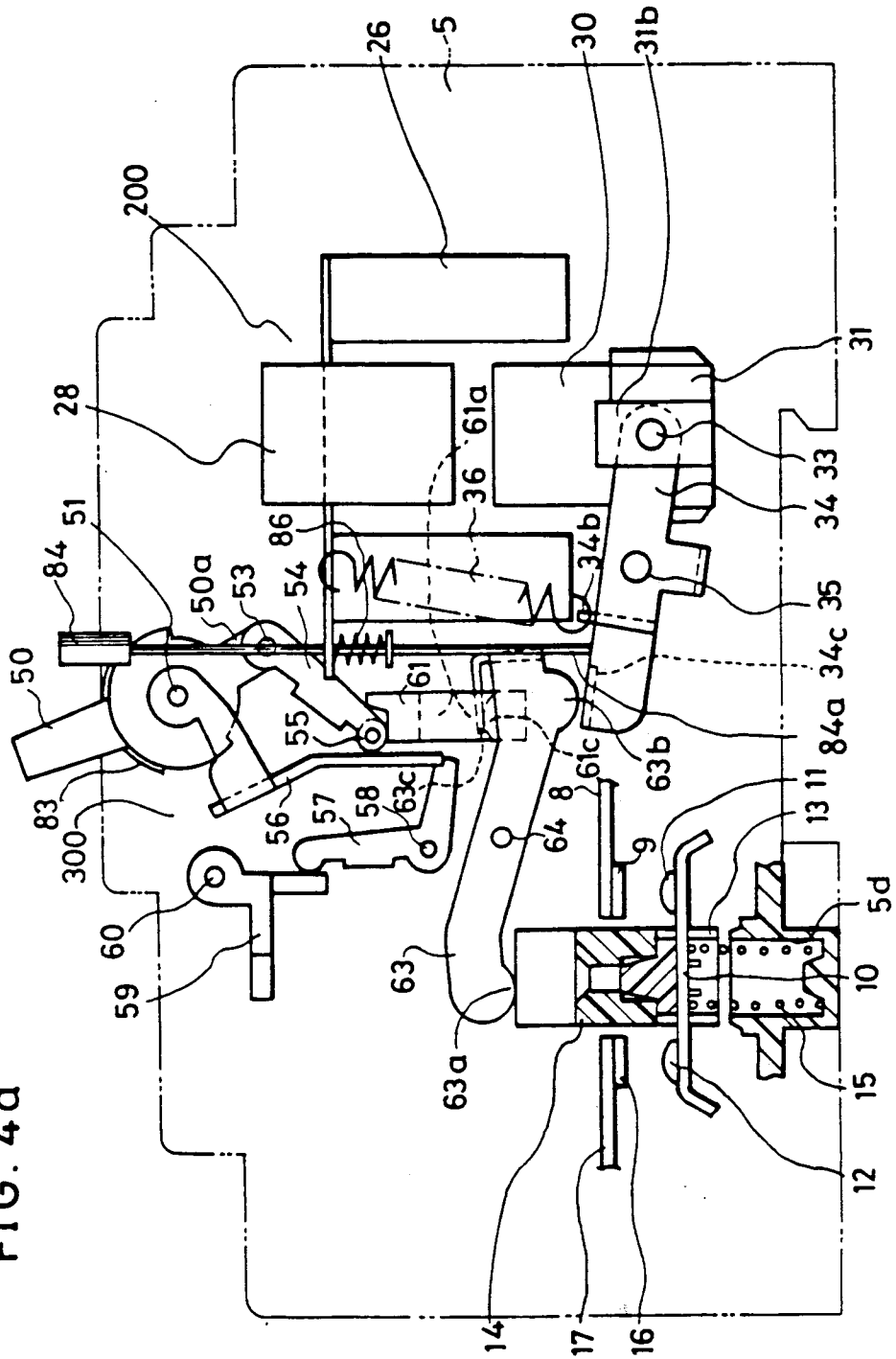
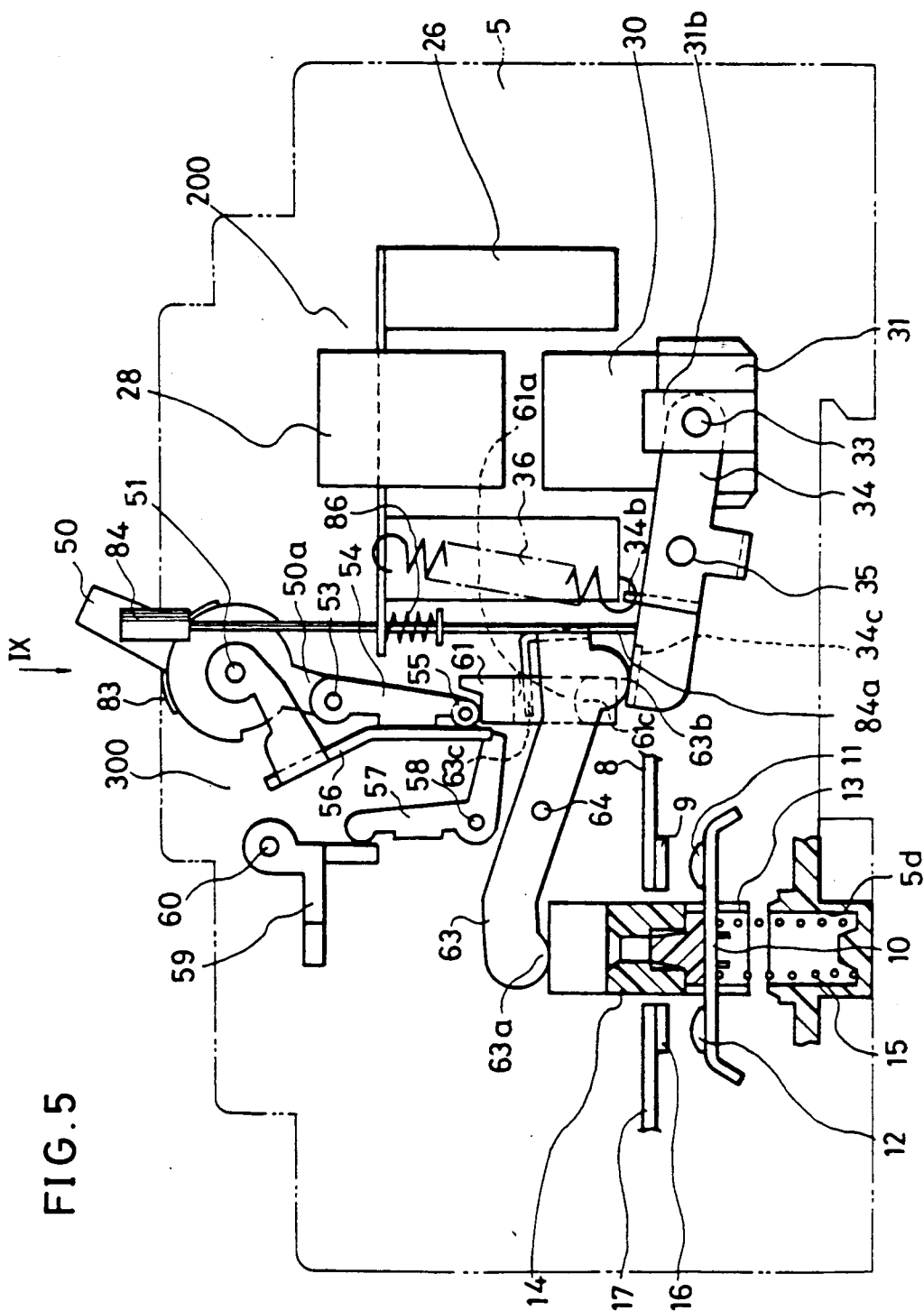

FIG. 4a





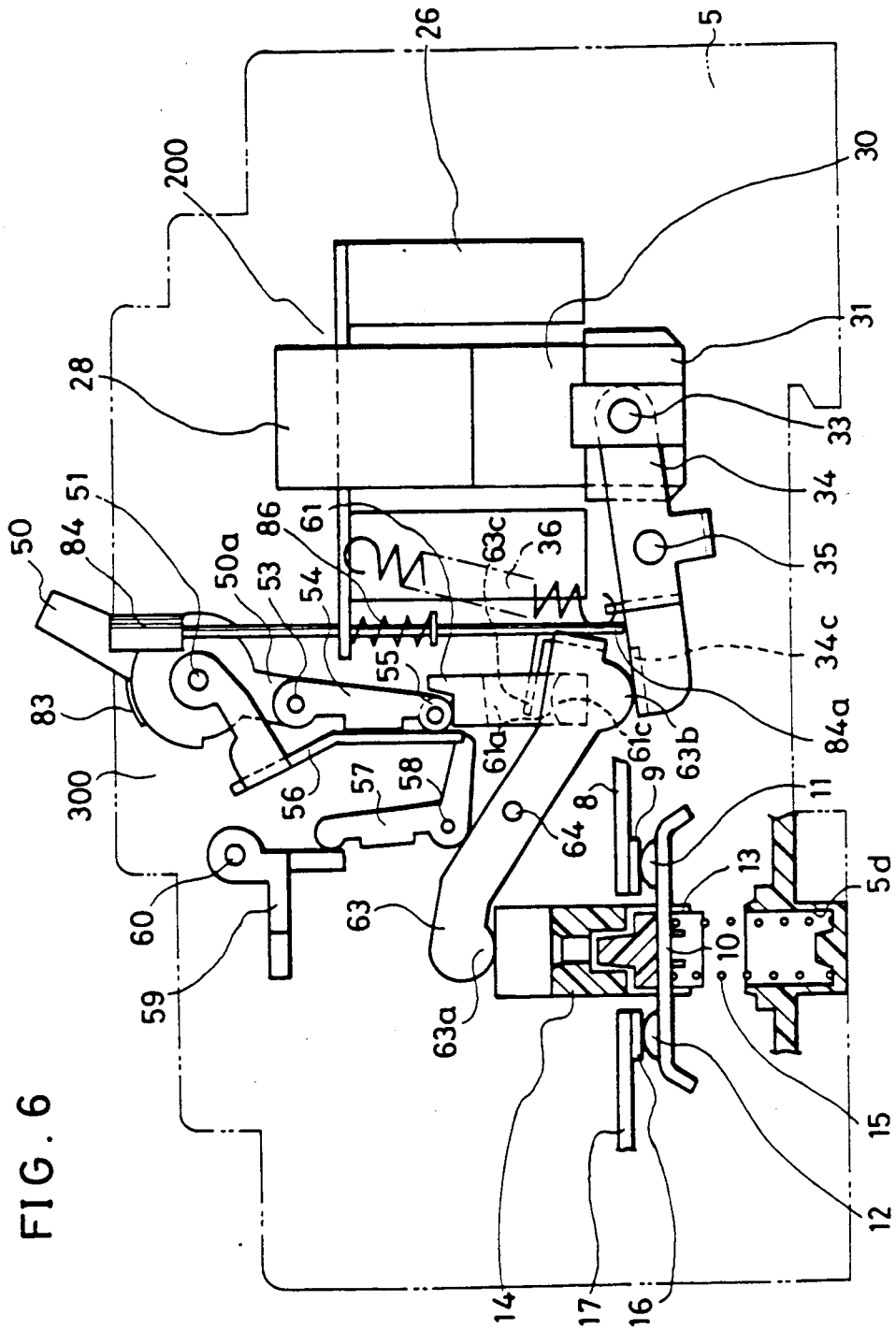

FIG. 6

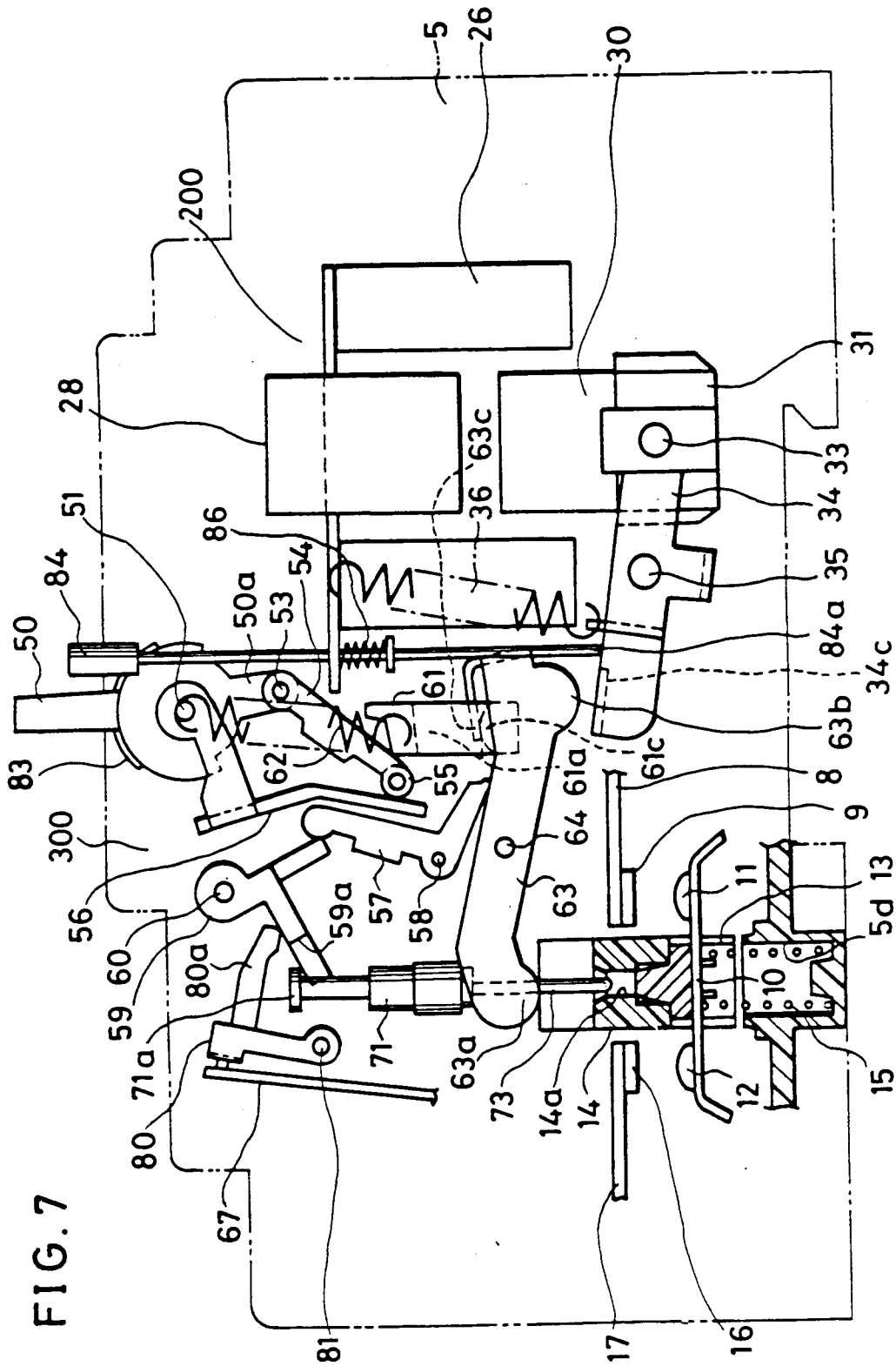

FIG. 8

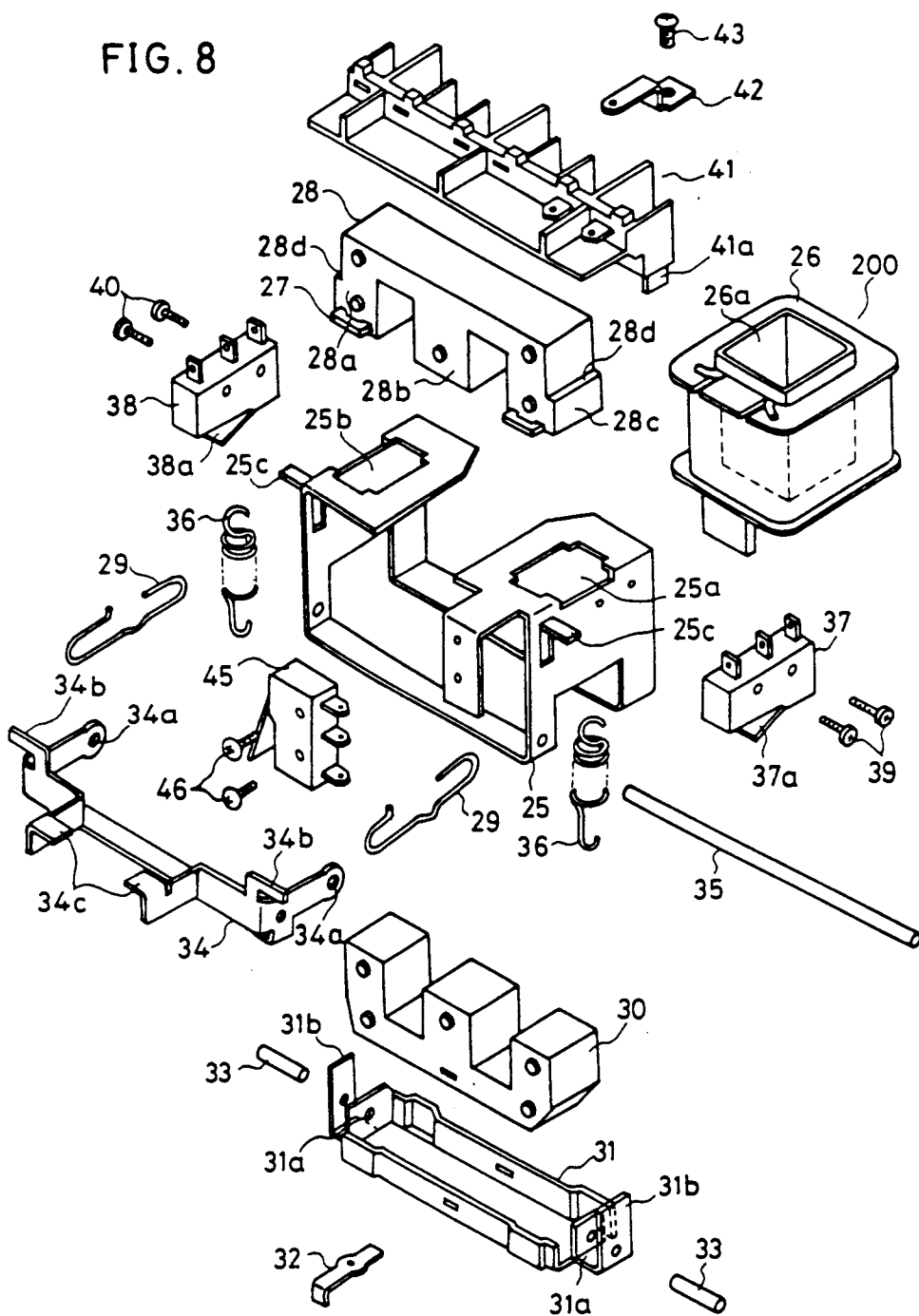

FIG. 9

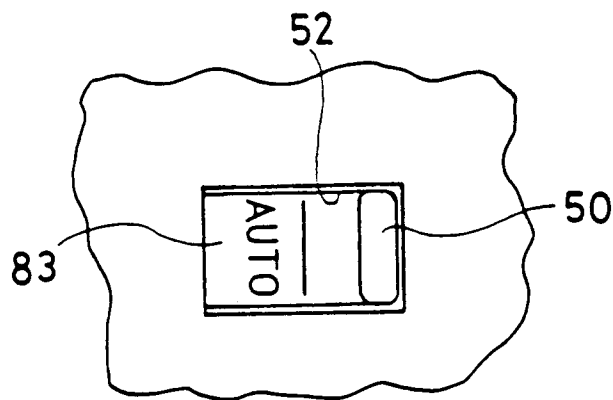
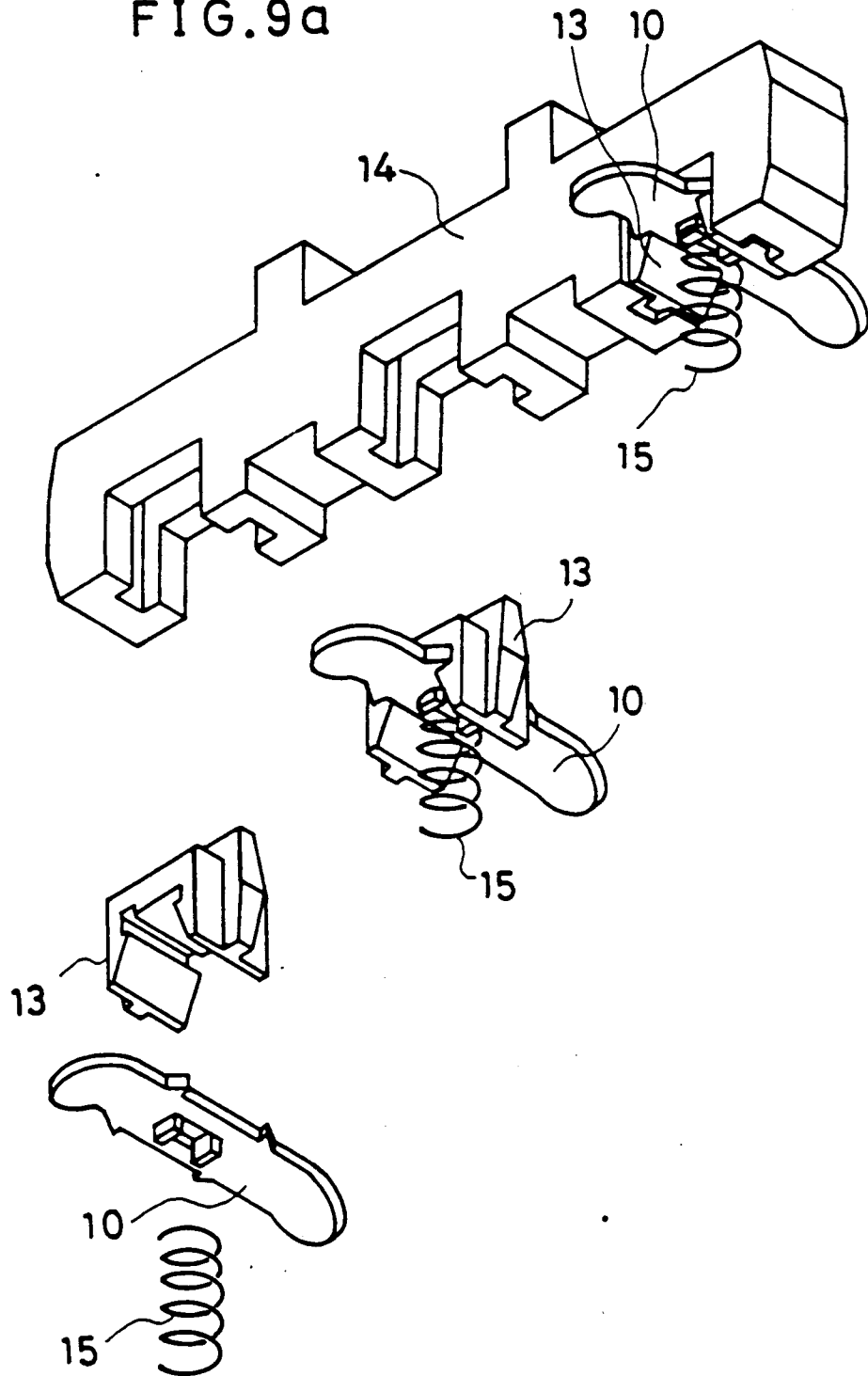
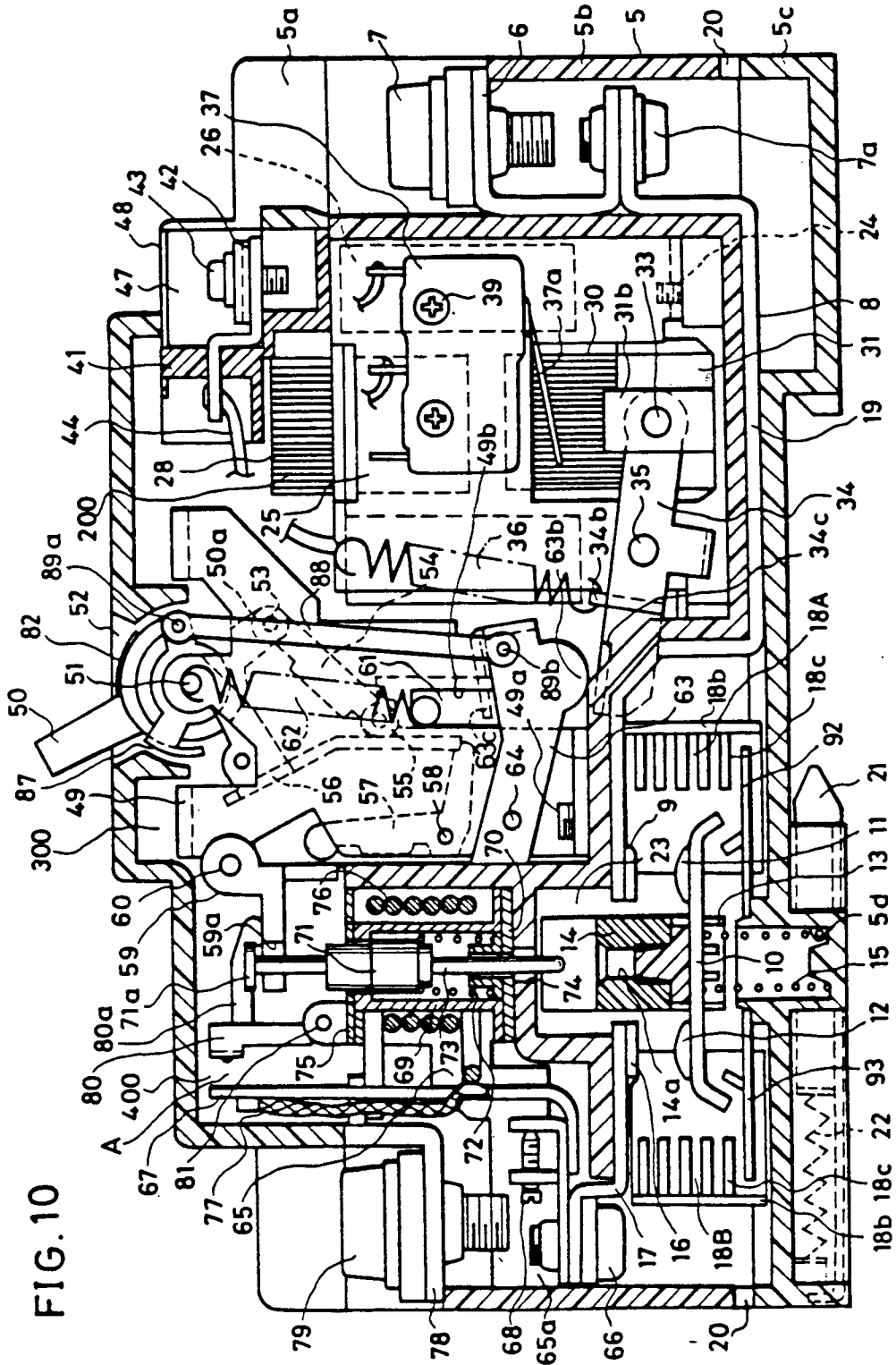

FIG. 9a





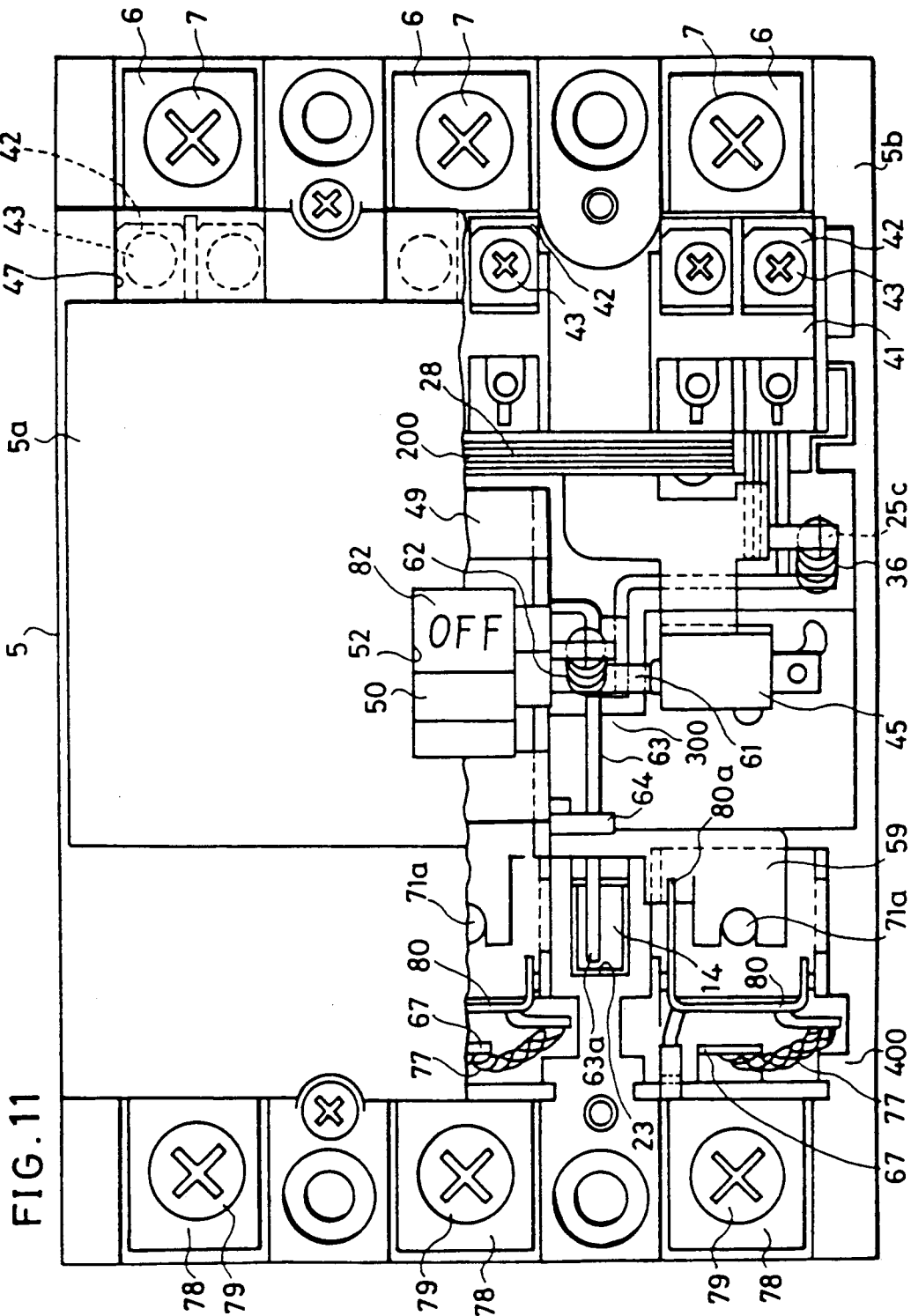

FIG. 11

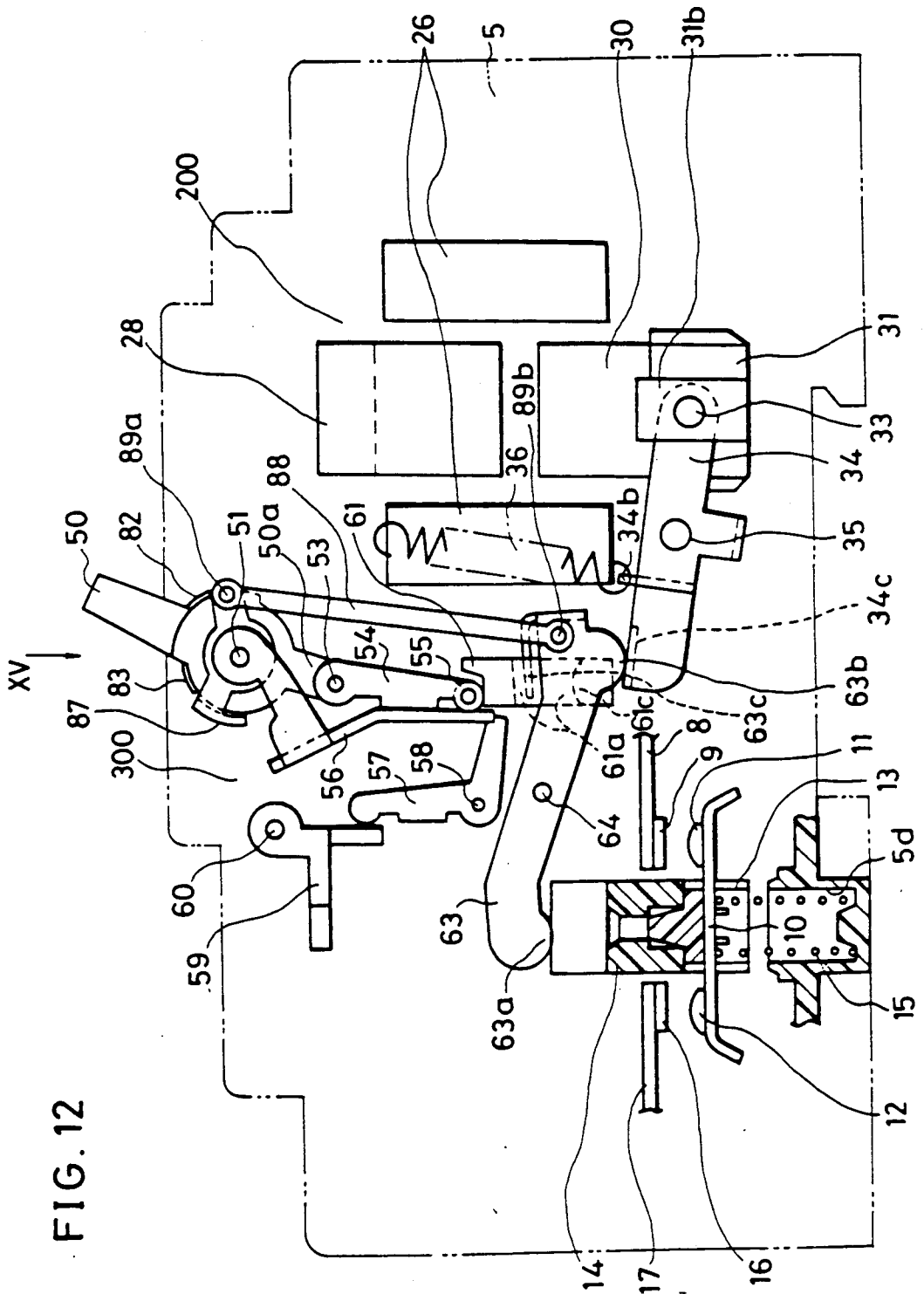
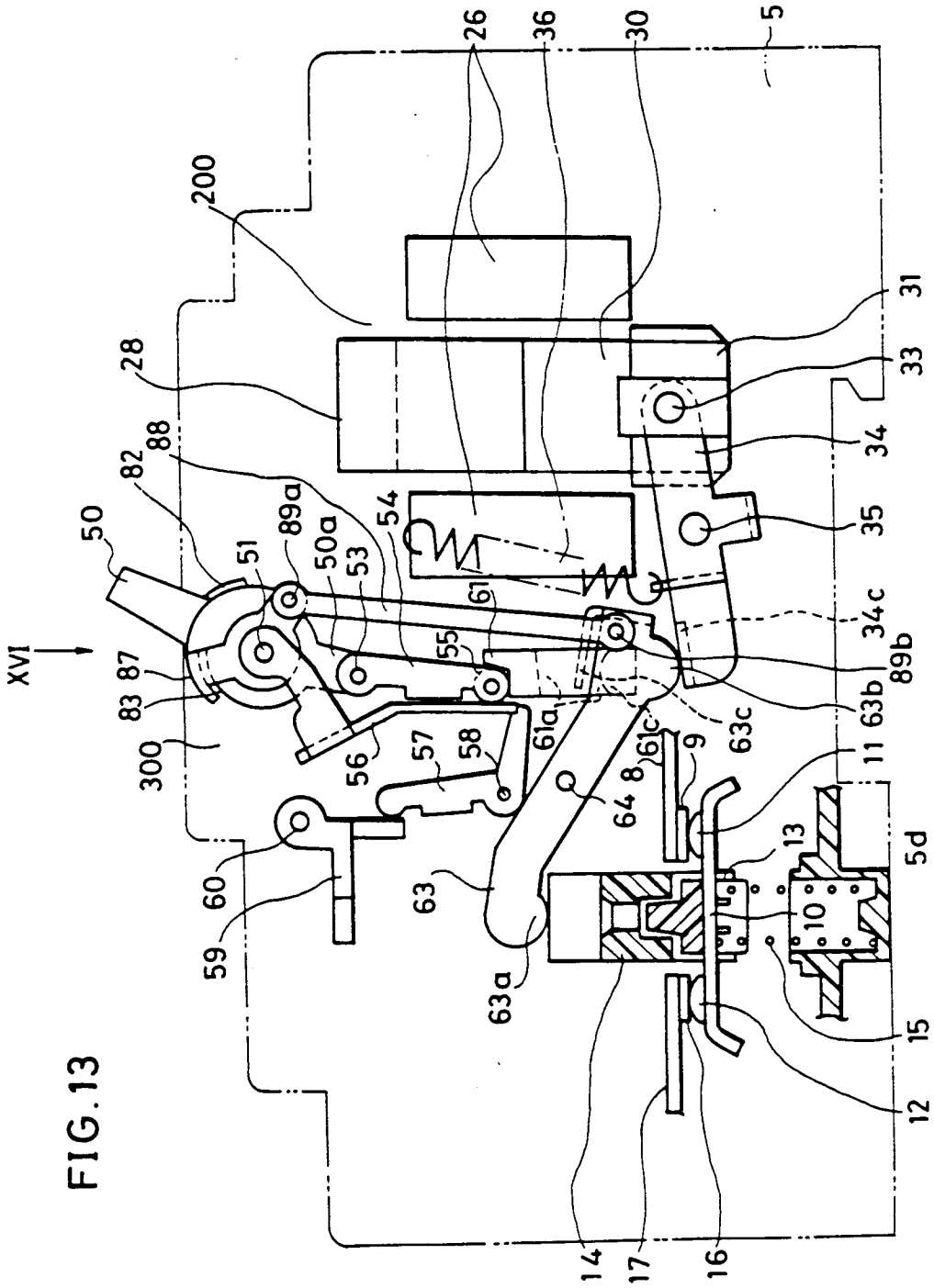

FIG. 12



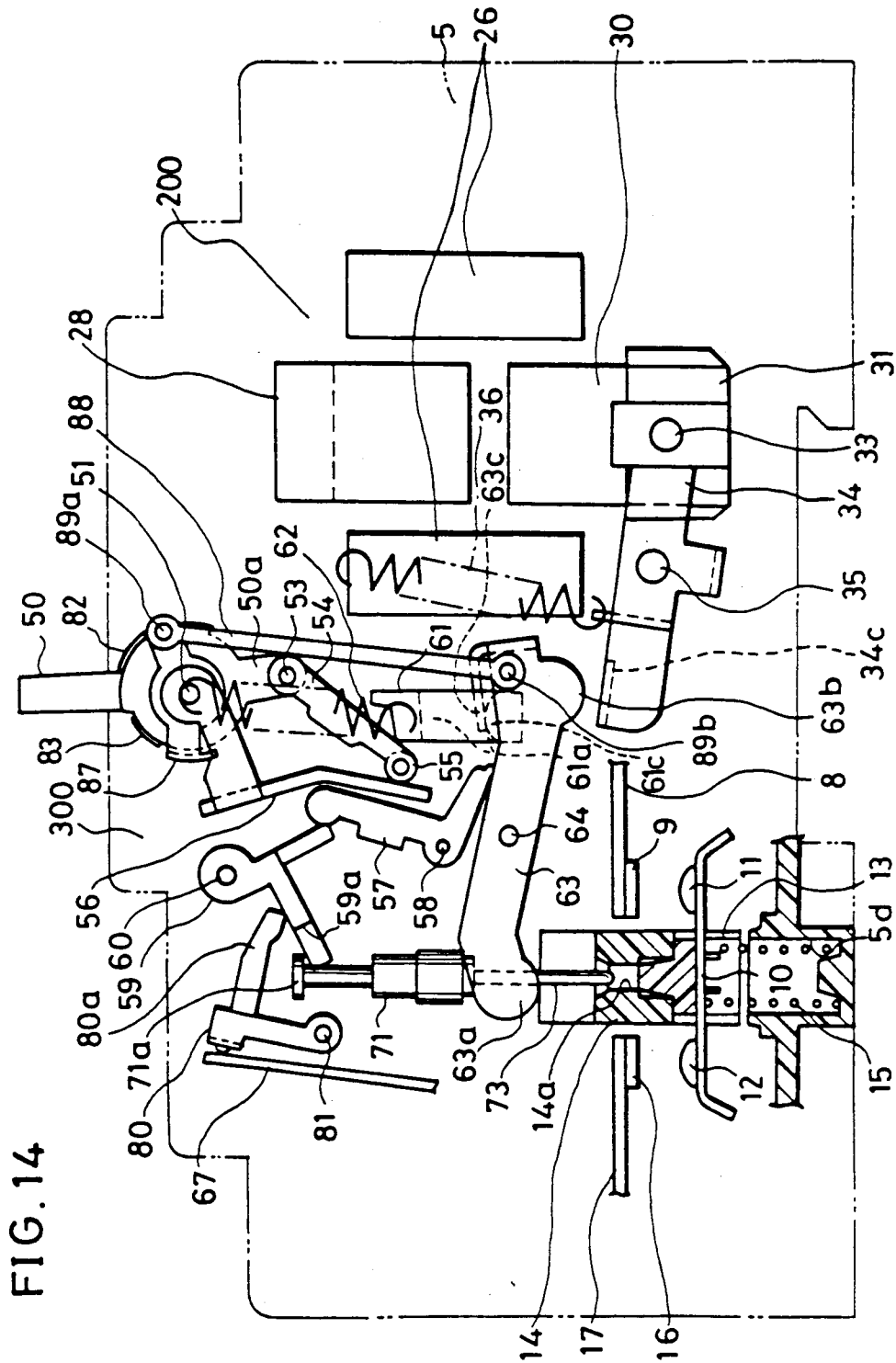

FIG. 14

FIG. 16

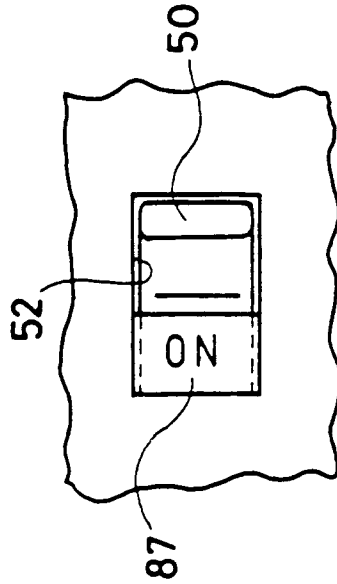
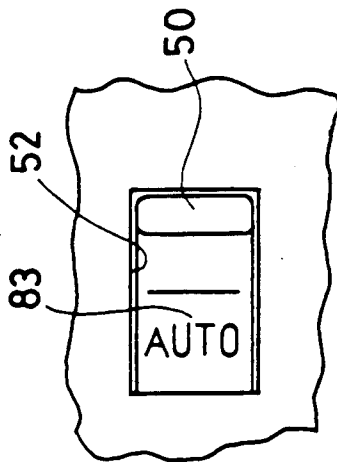

FIG. 15



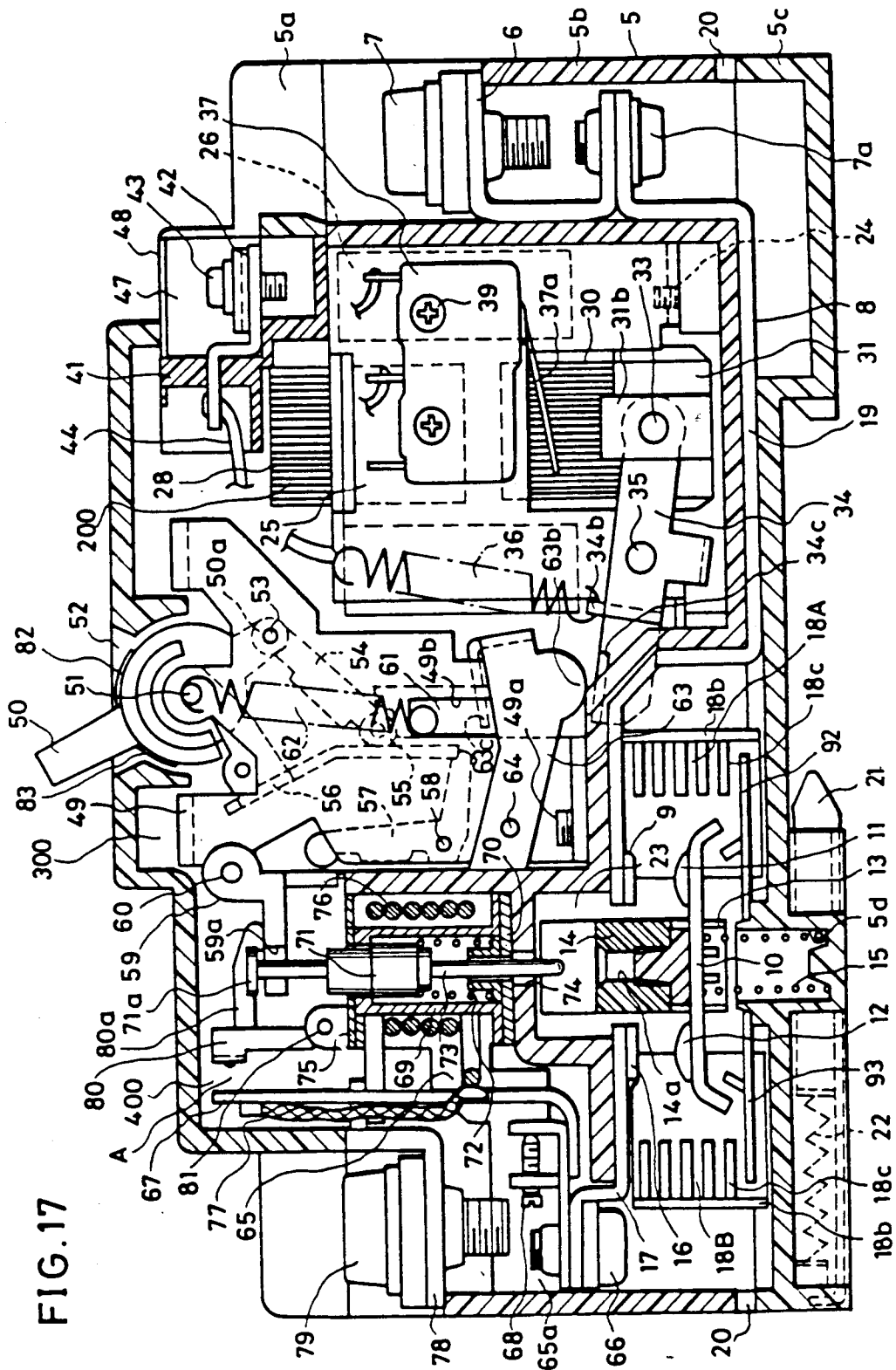

FIG. 17

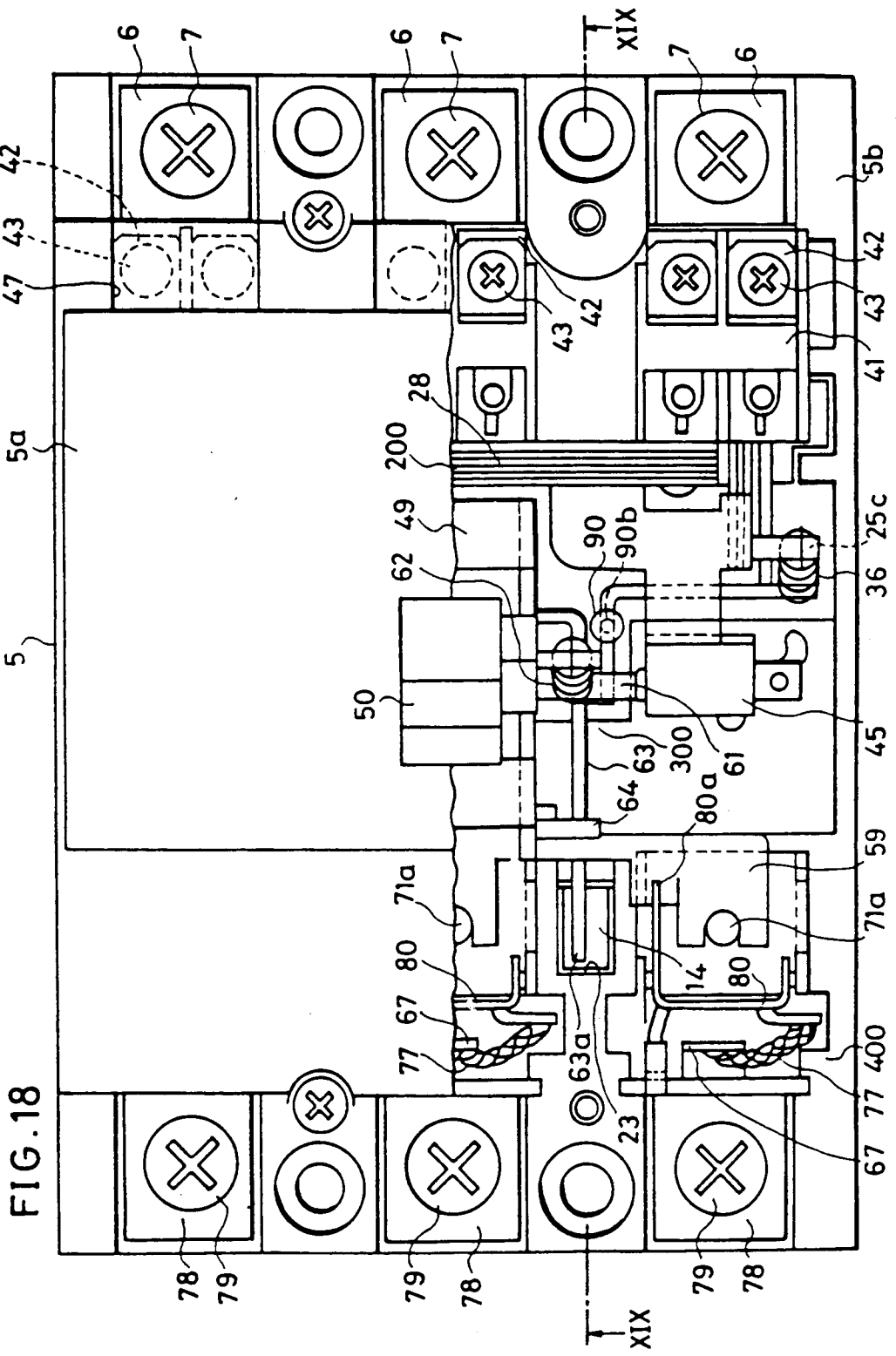
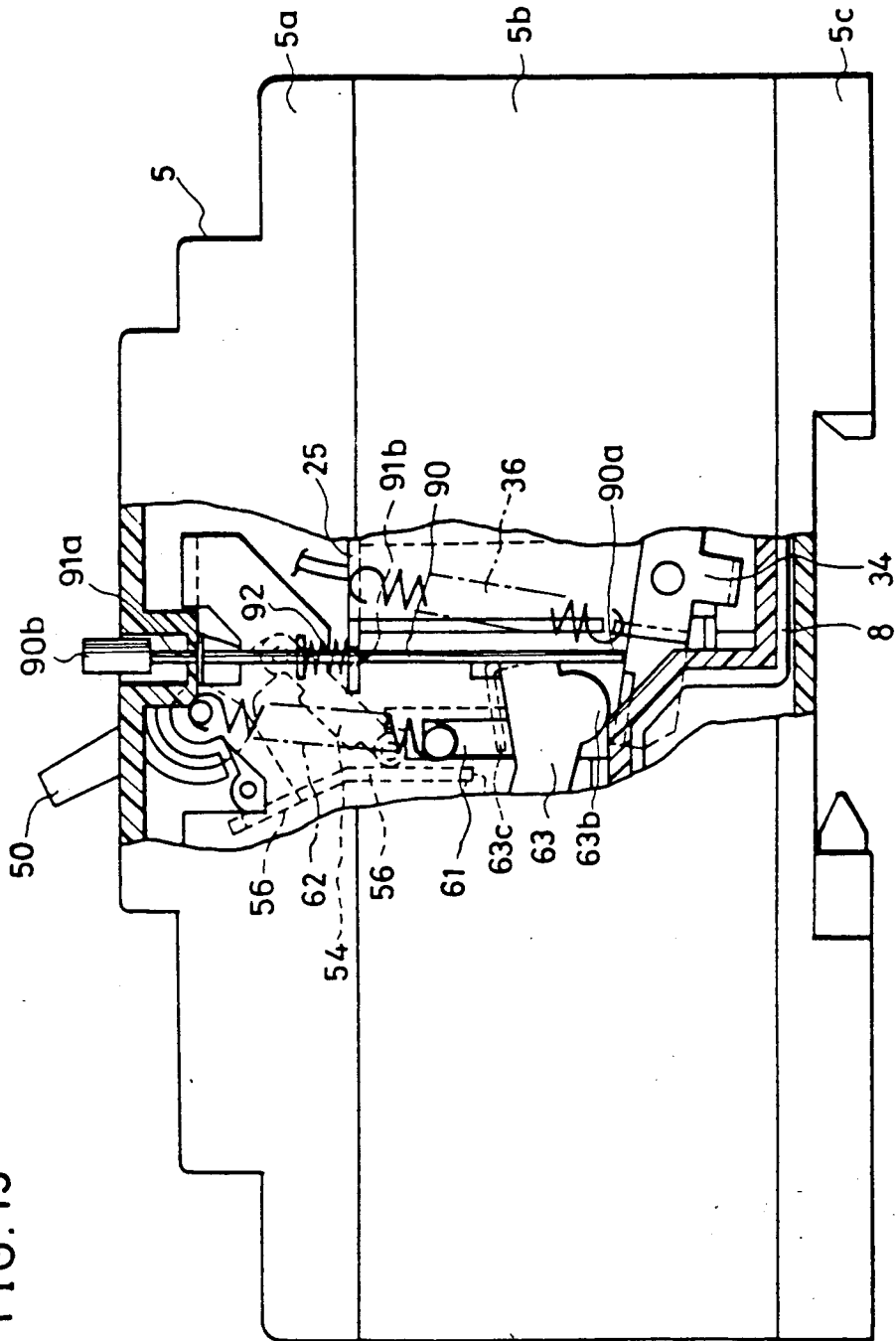

FIG. 19



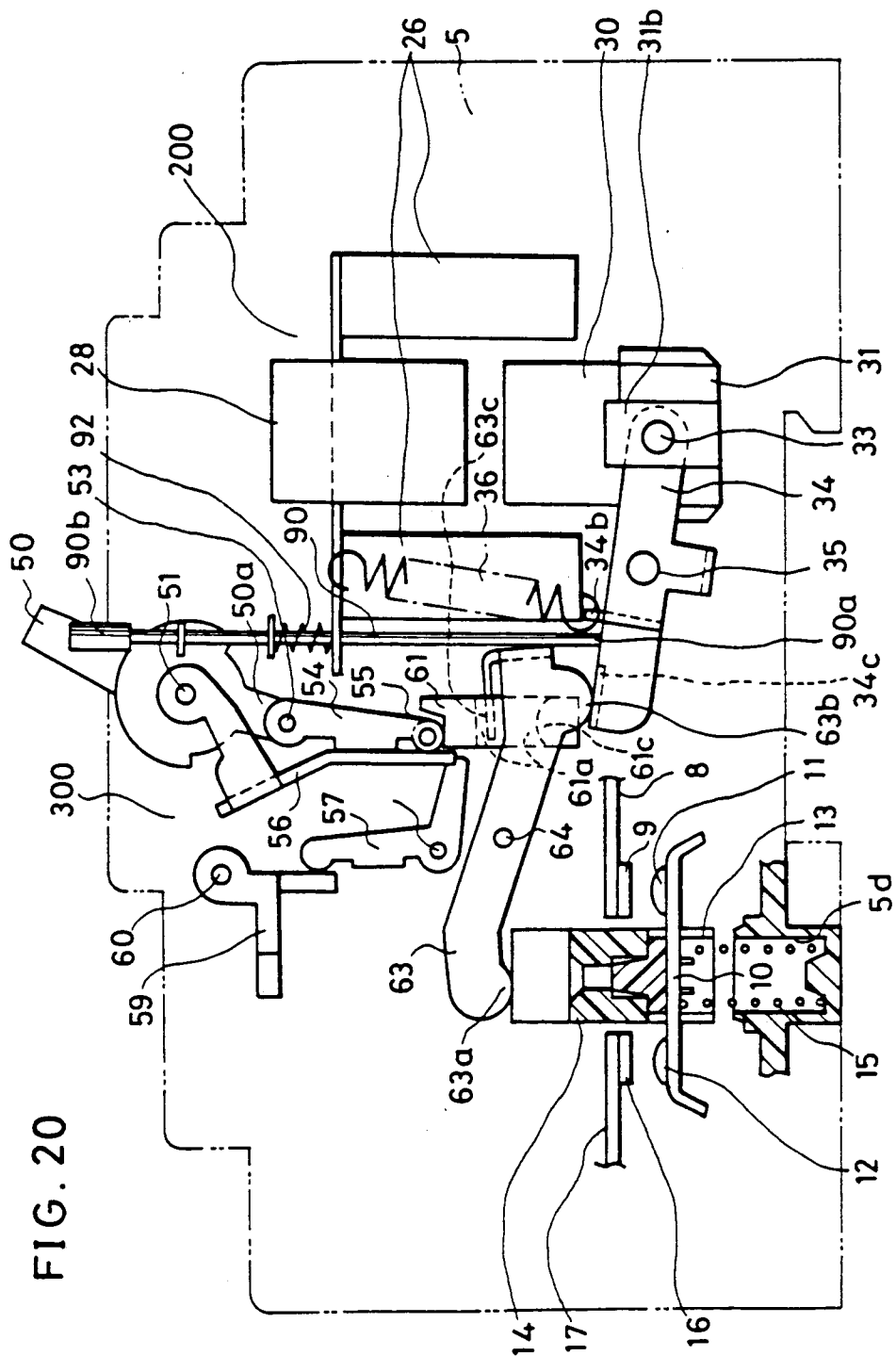
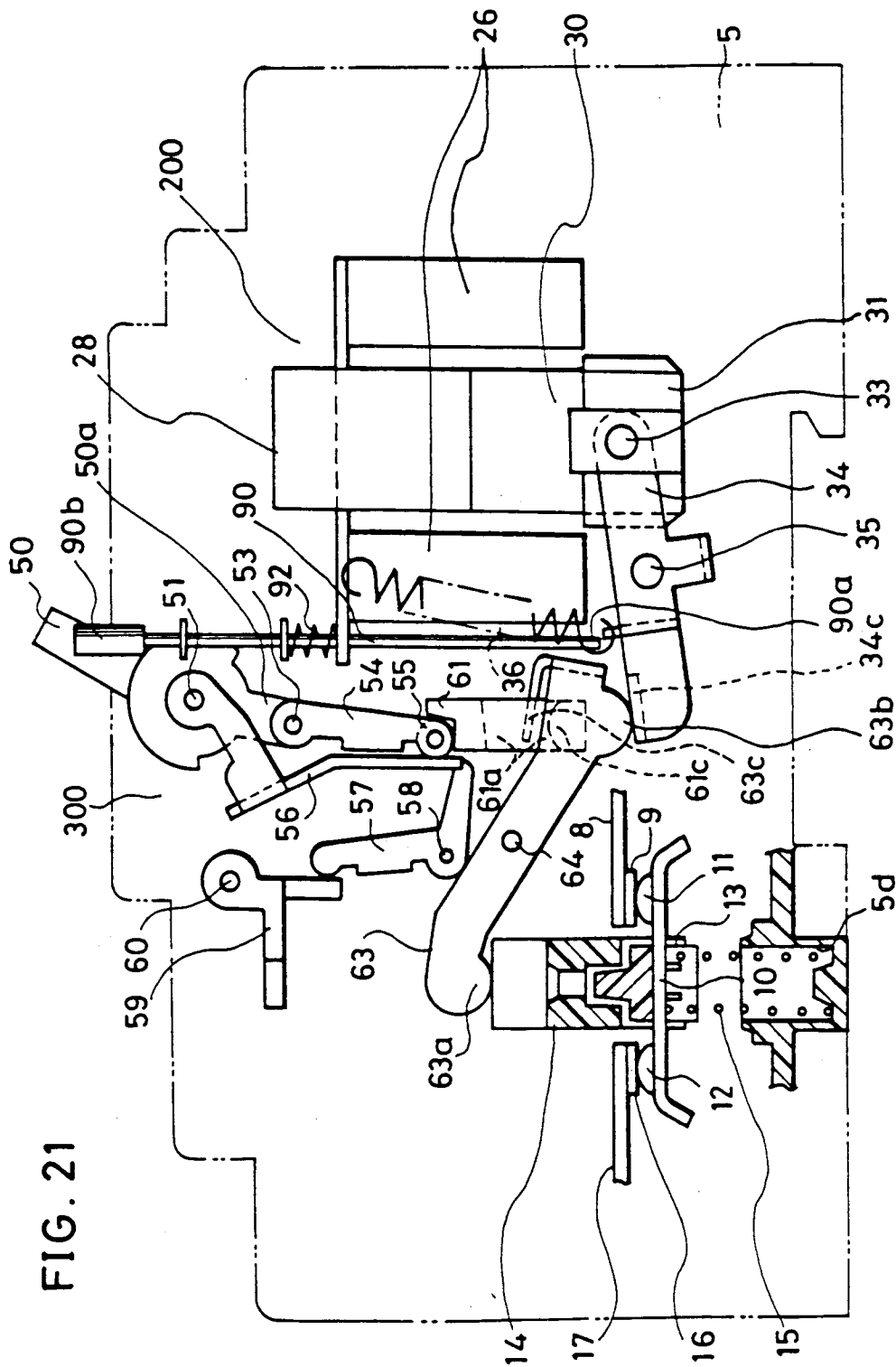
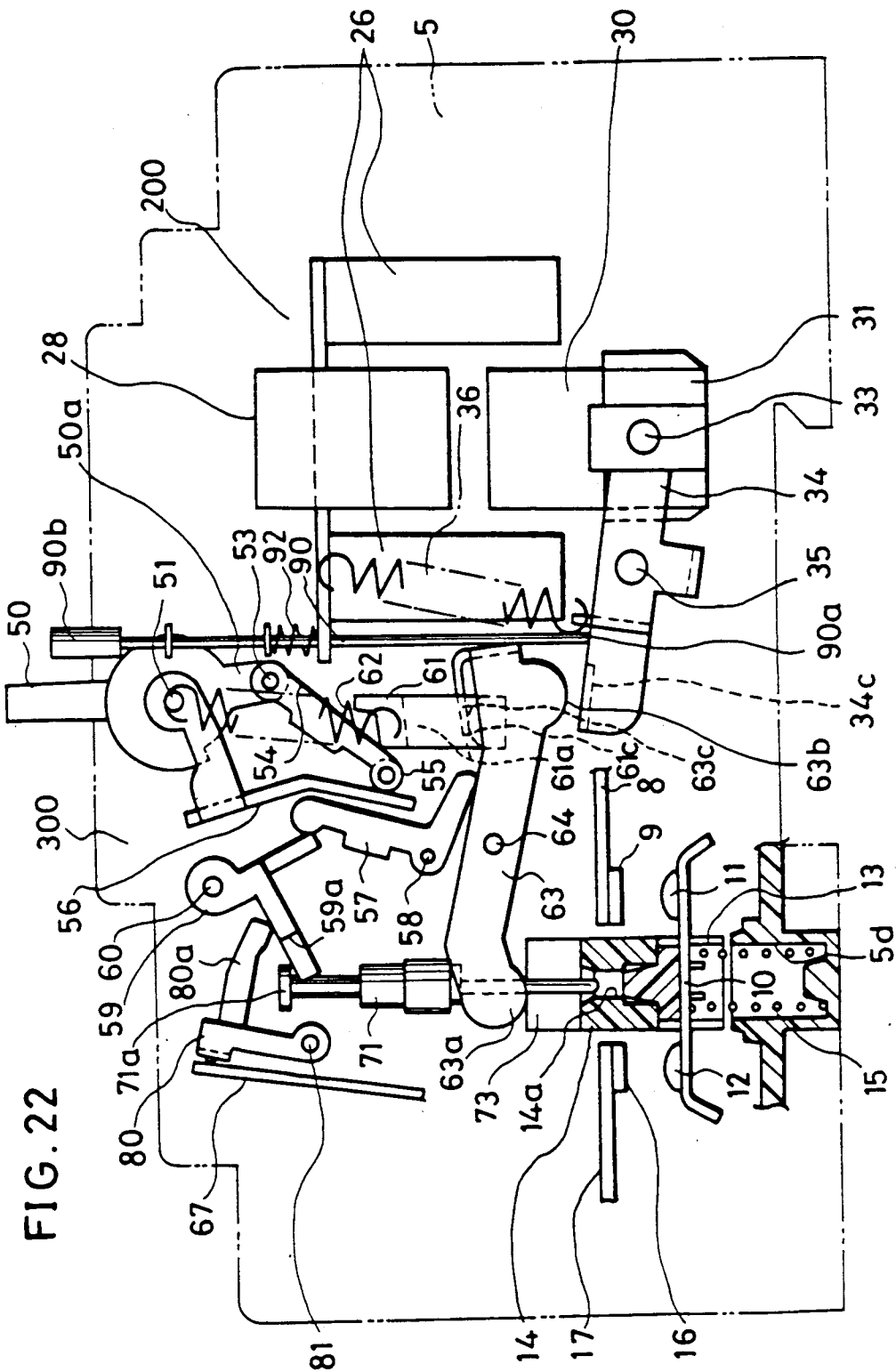

FIG. 21





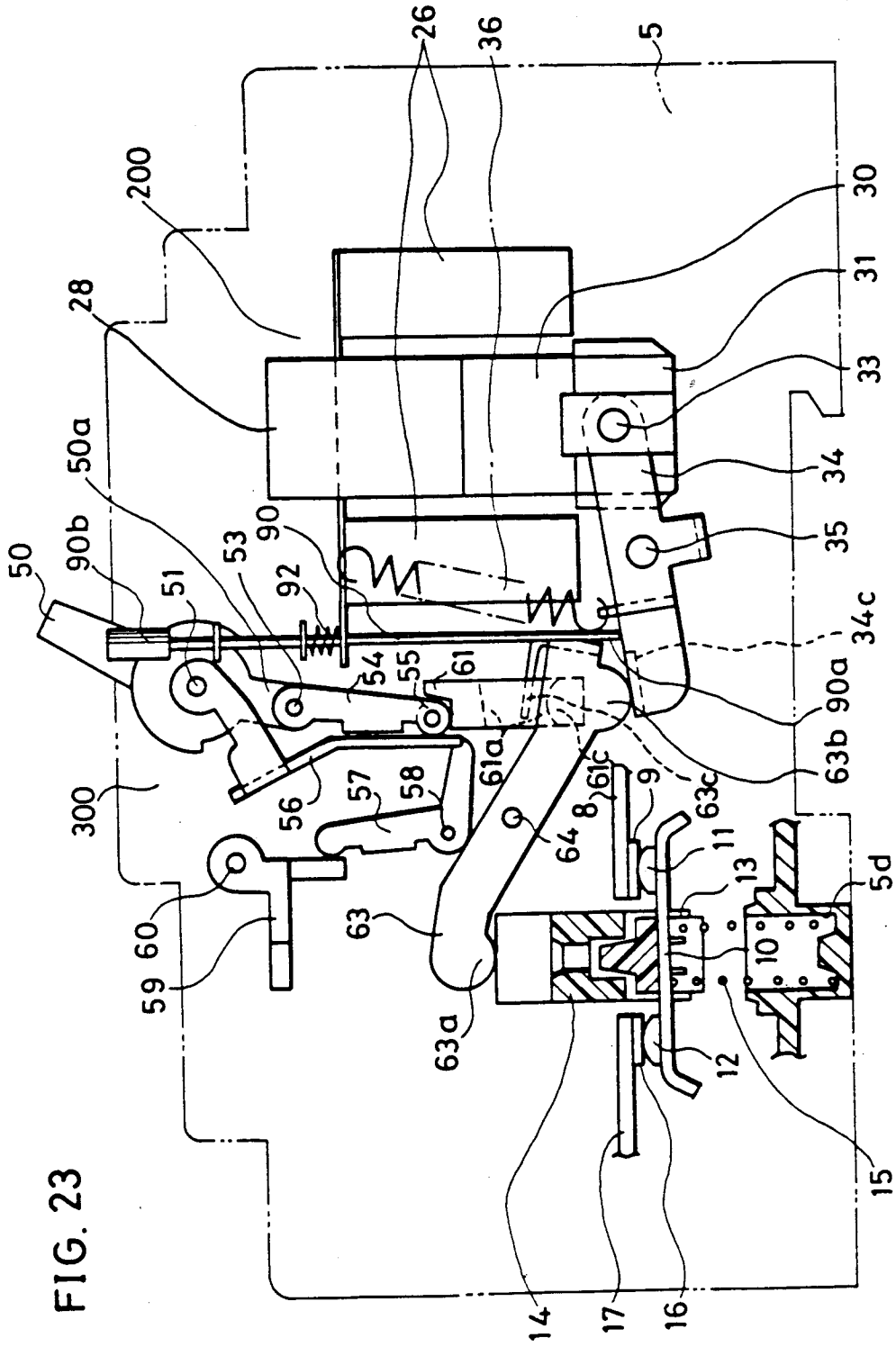

FIG. 23

FIG. 24 (Prior Art)

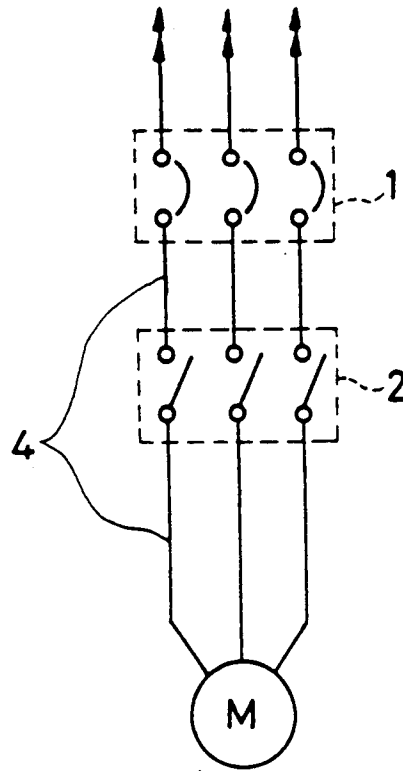
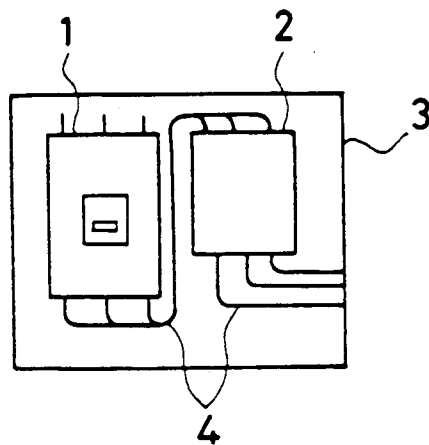

FIG. 25 (Prior Art)



REMOTE-CONTROLLED CIRCUIT BREAKER

BACKGROUND OF THE INVENTION

1. Field of the Invention

The present invention relates to a remote-controlled circuit breaker and more particularly to a remote-controlled circuit breaker having an improved high-frequency making/breaking operation.

2. Description of the Related Art

FIG. 24 is a schematic diagram showing a conventional driving circuit for a three-phase induction motor M. An A.C. voltage is applied to the motor M through electric power lines (not shown) via a conventional circuit breaker 1 and a magnetic contactor 2 connected in series with each other. The circuit breaker 1 is provided primarily to protect the motor M and connection wires 4 from heat damage caused by a short-circuit or an overload. Since the rated lifetime of the contacts of a conventional circuit breaker is generally under 10,000 switching cycles, the circuit breaker 1 is not suitable for making/breaking its contacts with high frequency. Further, it is difficult to effect remote-control operation of a conventional circuit breaker such as the circuit breaker 1.

On the other hand, the magnetic contactor 2 is suitable for making/breaking its contacts with fairly high frequency. If only the magnetic contactor 2 were used to drive the motor M, however, without the series-connected circuit breaker 1, welding of contacts in the magnetic contactor 2 could occur when a large current flows through the contacts as a result, for example, of a short circuit, rendering the magnetic contactor useless. For the above-mentioned reasons, the circuit breaker 1 and the magnetic contactor 2 are connected in series with each other, thereby realizing both a breaking function in response to an excessive current and a high-frequency making/breaking function susceptible to remote control.

As shown in FIG. 25, both the circuit breaker 1 and the magnetic contactor 2 are conventionally fixed to a common casing 3 to constitute a protection and control unit.

However, since the circuit breaker 1 and the magnetic contactor 2 are separate devices, many interconnecting wires 4 are necessary in the casing 3. In order to provide sufficient space to accommodate both devices (the circuit breaker 1 and the magnetic contactor 2), the interconnecting wires 4, and various wire connecting devices, the casing 3 must unavoidably be large.

U.S. Pat. No. 4,631,507 discloses a switching device having contacts which are actuated either by an armature of a remote-controllable electromagnet or by a tripping device. However, the mechanism for transmitting motion of the armature is provided independently of that for transmitting motion of the tripping device to the contacts without any substantial common component. Therefore, construction of the switching device is complicated, and the switching device is still not as compact as possible.

SUMMARY OF THE INVENTION

An object of the present invention is to provide a remote-controlled circuit breaker having breaking ability for large current and an ability for making/breaking contact with high frequency for the ordinary current

within a small-sized single integrated casing therefor, and, in particular, in a molded case circuit breaker.

In order to achieve the above-mentioned object, the remote-controlled circuit breaker of the present invention comprises:

a casing;

a fixed contact fixedly mounted to said casing;

a movable contact movably mounted to said casing to move in and out of contact with said fixed contact;

an electromagnetic unit comprising an electromagnetic coil and a fixed iron core which are fixedly mounted to said casing and a movable iron core movably mounted to said casing to be attracted to said fixed iron core;

a control lever which is pivotally mounted to said casing to move said movable contact into and out of contact with said fixed contact;

operation means, including an operation handle, for releasably holding said control lever, said operation means forming a toggle and holding said control lever in a position for moving said movable contact out of contact with said fixed contact when said operation handle is in a first position and releasing said control lever to allow a predetermined rotation thereof when said operation handle is in a second position;

an overcurrent tripping unit for causing said operation means and said control lever to actuate to move said movable contact out of contact with said fixed contact when a current greater than a predetermined value flows through said circuit breaker;

a transmission lever which is pivotally mounted to said casing to transmit a motion of said movable iron core to said control lever; and

a push rod movably mounted in said casing and having a first position in which said push rod projects out of said casing and a second position in which said push rod contacts said transmission lever.

In another aspect, the invention comprises:

a casing;

a fixed contact fixedly mounted to said casing;

a movable contact movably mounted to said casing to move in and out of contact with said fixed contact;

an electromagnetic unit comprising an electromagnetic coil and a fixed iron core which are fixedly mounted to said casing and a movable iron core movably mounted to said casing to be attracted to said fixed iron core;

a control lever which is pivotally mounted to said casing to actuate said movable contact into and out of contact with said fixed contact;

operation means, which includes an operation handle having a position indicator for indicating an off position of said circuit breaker and a remote-controllable position of said circuit breaker and forms a toggle for releasably holding said control lever, for holding said control lever in a position for moving said movable contact out of contact with said fixed contact at said off position of said operation handle and for releasing said control lever to allow a predetermined rotation thereof at said remote-controllable position of said operation handle;

an overcurrent tripping unit for causing said operation means and said control lever to actuate to separate said movable contact from said fixed contact when a current greater than a predetermined value flows through said circuit breaker;

a transmission lever which is pivotally mounted to said casing to transmit a motion of said movable iron core to said control lever;

an indicator which moves in accordance with said control lever to provide a visual indication of whether said movable contact makes contact with said fixed contact or not; and

a link lever for connecting said indicator with said control lever.

While the novel features of the invention are set forth particularly in the appended claims, the invention, both as to organization and content, will be better understood and appreciated, along with other objects and features thereof, from the following detailed description taken in conjunction with the drawings.

BRIEF DESCRIPTION OF THE DRAWINGS

FIGS. 1-9 are concerned with a first embodiment of the present invention.

FIG. 1 is a cross-sectional side view showing a remote-controlled circuit breaker with an operation handle 50 in its OFF-position and wherein a remote control command commands an OFF state.

FIG. 2 is a plan view of the circuit breaker with its front cover 5a partially removed.

FIG. 3 is a bottom view of the circuit breaker with its rear cover 5c partially removed.

FIG. 4 is a partially cross-sectional side view of the circuit breaker taken on line IV—IV in FIG. 2.

FIG. 4a is an internal side view showing main parts of the circuit breaker in an OFF state.

FIG. 5 is an internal side view showing main parts of the circuit breaker with the operation handle 50 in its AUTO-position and wherein the remote control command is for an OFF state.

FIG. 6 is an internal side view showing main parts of the circuit breaker with the operation handle 50 in the AUTO-position and wherein the remote control command an ON state.

FIG. 7 is an internal side view showing main parts of the circuit breaker in a trip state.

FIG. 8 is a perspective view showing components of an electromagnetic unit 200 in FIG. 1.

FIG. 9 is a partially plan view from IX (FIG. 5) showing the operation handle, etc.

FIG. 9a is a perspective view showing a movable conductor 10, a tension spring 15, a holder 13 and a crossbar 14 of a first embodiment of the present invention.

FIGS. 10-16 are concerned with a second embodiment of the present invention.

FIG. 10 is a cross-sectional side view showing a remote-controlled circuit breaker with an operation handle 50 its OFF-position and wherein a remote control commands an OFF state.

FIG. 11 is a plan view of the circuit breaker of FIG. 10 with its front cover 5a partially removed.

FIG. 12 is an internal side view showing main parts of the circuit breaker with the operation handle 50 in its AUTO position and wherein the remote control command is for the OFF state.

FIG. 13 is an internal side view showing main parts of the circuit breaker with the operation handle 50 in the AUTO-position and wherein the remote control command commands an ON state.

FIG. 14 is an internal side view showing main parts of the circuit breaker in a trip state.

FIG. 15 is a partially plan view from XV (FIG. 12) showing the operation handle 50 etc.

FIG. 16 is a plan view from XVI(FIG. 13) showing the operation handle 50 etc.

FIGS. 17-23 are concerned with a third embodiment of the present invention.

FIG. 17 is a cross-sectional side view showing a remote-controlled circuit breaker with an operational handle 50 in its OFF-position and wherein a remote control command commands an OFF state.

FIG. 18 is a plan view of the circuit breaker with its front cover 5a partially removed.

FIG. 19 is a partially cross-sectional side view of the circuit breaker taken on line XIX—XIX in FIG. 18.

FIG. 20 is an internal side view showing main parts of the circuit breaker with the operation handle 50 in its AUTO-position and wherein the remote control command is for an OFF state.

FIG. 21 is an internal side view viewing main parts of the circuit breaker with the operation handle 50 in the AUTO-position and wherein the remote control command commands an ON state.

FIG. 22 is an internal side view showing main parts of the circuit breaker in a trip state.

FIG. 23 is an internal side view showing main parts of the circuit breaker in a manual ON state.

FIG. 24 is a schematic diagram of a conventional driving circuit for a three-phase induction motor.

FIG. 25 is a plan view of the circuit breaker 1 and the magnetic contactor 2 which are mounted onto the casing 3.

It will be recognized that some or all of the Figures are schematic representations for purposes of illustration and do not necessarily depict the actual relative sizes or locations of the elements shown.

DESCRIPTION OF THE PREFERRED EMBODIMENTS

Hereafter, preferred embodiments of the present invention are described with reference to the accompanying drawings.

FIGS. 1-9 are concerned with a first embodiment of the present invention. FIG. 1 is a cross-sectional side view showing a remote-controlled circuit breaker with an operation handle 50 in its OFF-position and wherein a remote control commands an off state. FIG. 2 is a plan view of the circuit breaker with its front cover 5a partially removed. FIG. 3 is a bottom view of the circuit breaker with its rear cover 5c partially removed. FIG. 4 is a partially cross-sectional side view of the circuit breaker taken on line IV—IV in FIG. 2. FIG. 5 is an internal side view showing main parts of the circuit breaker with the operation handle 50 in its AUTO (automatic)-position and wherein the remote control command is for the off state. FIG. 6 is an internal side view showing main parts of the circuit breaker with the operation handle 50 in the AUTO-position and wherein the remote control command commands an on state. FIG. 7 is an internal side view showing main parts of the circuit breaker in a trip state.

In FIG. 1, a casing 5 comprises a front cover 5a, a base 5b and a rear cover 5c. A terminal 6 of power-source side is fixed in the base 5b and has a screw 7 thereon. A fixed conductor 8, one end of which is connected with the terminal 6 by a screw 7a, is held under the base 5b as a power-source side conductor. A fixed contact 9 of the power-source side is fixed on the other end of the fixed conductor 8. A movable conductor 10, which is movably mounted on the casing 5, has a pair of movable contacts 11 and 12. The movable contact 11 is disposed to make contact with the fixed contact 9, and the movable contact 12 is disposed to make contact with

a fixed contact 16 which is fixed to a fixed conductor 17 of load-side.

The movable conductor 10 is held by a holder 13 which is made of insulating material. A crossbar 14 is disposed to traverse the movable conductors 10 of all phases, thereby straddling over the movable conductors 10. The holder 13 is slidably fit in a groove 14a of the crossbar 14. A compression spring 15, which is mounted in a hole 5d formed in the rear cover 5c, urges the movable conductor 10 upward, thereby to make contact between the fixed contacts 9, 16 and the movable contacts 11, 12, respectively.

FIG. 9a is a perspective view showing detailed construction of the movable conductor 10, the holder 13, the crossbar 14 and the compression spring 15.

In FIG. 1, arc extinguishing chambers 18A and 18B are provided in a right-hand side and a left-hand side of the holder 13, respectively. Each of the arc extinguishing chambers 18A and 18B comprises a pair of insulating sheets 18a (FIG. 3), an exhaust sheet 18b (FIG. 3) and plural grids 18c encircled by the insulating sheets 18a and the exhaust sheet 18b. The grids 18c are made of a magnetically soft (low coercivity) substance such as iron sheet. An exhaust passage 19 (FIGS. 1 or 3) formed by the base 5b and the rear cover 5c communicates with a pair of vents 20 which are formed in right and left ends of the base 5b in FIG. 1. A metal finger 21, which is slidably held by the rear cover 5c, is urged by a spring 22 rightward in FIG. 1.

The above-mentioned parts 8-17 constitute a contact part in a space partitioned by the base 5b and the rear cover 5c. The crossbar 14 is actuated by a control lever 63 and an overcurrent tripping part 400 within a space 23.

In the front part of the power-source side of the circuit breaker, an electromagnetic unit 200 is fixed on the base 5b by a screw 24. FIG. 8 is a perspective view showing components of the electromagnetic unit 200. An assembling procedure for the electromagnetic unit 200 is described with reference to FIG. 8. First, an electromagnetic coil 26 is inserted into a channel-shaped magnet frame 25. Next, leg numbers 28a, 28b and 28c of a fixed iron core 28 are inserted into an opening 25b, an opening 26a, and an opening 25a, respectively. Each of the leg members 28a and 28c has a shading coil 27 at an end part thereof. An elastic element 29 such as a spring is provided between a projecting part 28d of the fixed iron core 28 and the magnet frame 25 to prevent the fixed iron core 28 from coming out of the magnet frame 25 and to absorb any shock caused by attracting a movable iron core 30. The movable iron core 30 is fixed to a holder 31 by a stopper 32. A pair of bearing members 31a are provided at both ends of the holder 31, and these bearing members 31a are rotatably held by a pair of bearing members 34a of a transmission lever 34 with a pair of pins 33. The transmission lever 34 is held by the magnet frame 25 with a shaft 35. A pair of tension springs 36 are extended between respective projections 34b of the transmission lever 34 and respective projections 25c of the magnet frame 25 to thereby move the movable iron core 30 away from the fixed iron core 28.

A pair of auxiliary switches 37 and 38 are secured to the magnet frame 25 by screws 39 and 40. A pair of projections 31b of the holder 31 are disposed to engage with actuator 37a and 38a, respectively. In response to the movement of the movable iron core 30, the respective actuators 37a and 38a are actuated, thereby ma-

king/breaking contact in the auxiliary switches 37 and 38.

A terminal block 41 has plural terminals 42 inserted thereto, and plural screws 43 for connecting external wires (not shown) are provided. Some of the terminals 42 are connected to the auxiliary switches 37 and 38 via lead wires 44 (FIG. 1), and the other terminals 42 are connected to the electromagnetic coil 26 directly and via a limit switch 45. That is, the limit switch 45 and the electromagnetic coil 26 of the electromagnetic unit 200 are connected in series with each other. The limit switch 45 is fixed to the magnet frame 25 by screws 46. The screws 43 are accessible through an opening 47 (FIG. 1) in the front cover 5a to enable connection to external wires. The terminal block 41 is fixed on the magnet frame 25 by leg members 41a. The terminal block 41 is usually covered with a terminal cover 48 (FIG. 1) to prevent accidental contact.

An operation mechanism unit 300 is located in the front-mid part of the circuit breaker in FIG. 1. A frame 49 is fixed to the base 5b by a screw 49a. The operation handle 50, which projects out of an opening 52, is rotatably held to the frame 49 by a pin 51. An inner protuberance 50a of the operation handle 50 is connected with one end of a link 54 by a pin 53, thereby constituting a toggle link mechanism. A roller 55 is pivotally mounted on the other end of the link 54. A lever 56 is pivotally mounted to the frame 49 by the pin 51. A lower end of the lever 56 is engaged with a latch 57. The latch 57 is pivotally mounted to the frame 49 by a pin 58 and is biased to rotate counterclockwise by a torsion spring (not shown). A trip bar 59 is pivotally mounted to the frame 49 by a pin 60 and is urged to rotate clockwise by a torsion spring (not shown), thereby engaging with the latch 57. A pusher plate 61 is movably mounted in each of holes 49b of the frame 49 in the up and down direction. The pusher plate 61 is biased to move upward by a tension spring 62. The roller 55 rides on an upper end of the pusher plate 61, and the lever 56 is engaged with the roller 55. The control lever 63 is pivotally mounted to the frame 49 by a pin 64. In FIG. 5, one end 63a of the control lever 63 is engaged with the crossbar 14, and the other end 63b thereof is engaged with an engaging member 34c of a transmission lever 34. A bearing surface 63c of the control lever 63 is disposed between contacting surfaces 61a of the pusher plate 61 so that the control lever 63 is allowed to rotate only within a predetermined angular range. In the state of FIG. 1, namely in the OFF-position of the operation handle 50, the right end 63b of the control lever is lifted by the tension spring 62 via the pusher plate 61. Since the urging force applied to the movable conductor 10 by the tension spring 62 is larger than that by the compression spring 15, the control lever 63 is held in a state of FIG. 1. Therefore, both the movable contacts 11 and 12 are detached from the fixed contacts 9 and 16, respectively. At that time, there is a gap between the end 63b of the control lever 63 and the engaging member 34c of the transmission lever 34 as shown in FIG. 1.

Towards the front of the load-side of the circuit breaker, an overcurrent tripping unit 400 having a bimetal and a plunger-shaped electromagnet is provided. The fixed conductor 17 of the load side is secured to an end 65a of a first yoke 65 by a screw 66, and the first yoke 65 has the bimetal 67 welded thereto and an adjusting screw 68. In a bobbin 69, a hollow core 70 secured to the first yoke 65 and a plunger 71 are provided. The plunger 71 is urged to move upward by a compres-

sion spring 72. An upper end part 71a of the plunger 71 is engaged with a hole 59a of the trip bar 59. When the plunger 71 is attracted to the core 70, the trip bar 59 is rotated against the torsion spring (not shown). A rod 73 is disposed to pass through a hollow of the core 70 and an opening 74 of the base 5b. When the plunger 71 is attracted to the core 70, the rod 73 lowers through a groove 14a of the crossbar 14 and hits the holder 13, thereby breaking contact between the contacts 9 and 11 and between contacts 16 and 12. A second yoke 75 is secured to the first yoke 65. One end of the coil 76 is connected to an upper end part of the bimetal 67 via a flexible copper wire 77, and the other end thereof is connected to a terminal 78 of the load side. The terminal 78 has a screw 79 for securing an external wire (now shown). An actuator 80 is pivotally mounted to the first yoke 65 by a pin 81 and is urged to move counterclockwise by a spring (now shown). An arm member 80a of the actuator 80 is provided to engage with the trip bar 59. Delay time for tripping the circuit breaker is adjusted by varying the width of a gap A between the upper end part of the bimetal 67 and the opposing actuator 80. The gap A is made larger or smaller by turning the adjusting screw 68.

An indication label 82 for indicating an off state of the circuit breaker is provided on the operation handle 50, and an indication label 83 for indicating an automatic (remote-controllable) state of the circuit breaker is provided on the operation handle 50. In FIG. 4, a push rod 84 is slidably held in the vertical direction by a hole 85b of the magnet frame 25 and a hole 85a of the front cover 5a. The push rod 84 is always biased downward by a weak spring 86. Therefore, a lower end 84a of the push rod 84 abuts onto the transmission lever 34, thereby following the motion of the transmission lever 34.

Next, operation of the above-mentioned circuit breaker is described.

In the off state of the circuit breaker as shown in FIGS. 1-4a, the indication label 82 for indicating the off state can be observed through the opening 52 of the front cover 5a (FIG. 2). Therefore, the on or off state of the circuit breaker can be visually confirmed by an operator. When the operation handle 50 is pushed to the right to thereby set it in the AUTO-position, the link 54 and the operation handle 50 are disposed on an approximately straight line as shown in FIG. 5. The pusher plate 61 is thereby lowered against a force of the spring 62 (FIG. 1), and the bearing surface 63c of the control lever 63 relatively comes into a high position between contacting surfaces 61a of the pusher plate 61. Accordingly, the control lever 63 is released from a state in which clockwise rotation is restricted by presence of the contacting surface 61c, which is the lower of the contacting surfaces 61a. As a result, the control lever 63 receives the force of the spring 15 via the crossbar 14 and is thereby rotated clockwise. When the control lever 63 abuts on the transmission lever 34, rotation of the control lever 63 is stopped by the tension spring 36 which urges the transmission lever 34 to rotate clockwise. This is because the force due to the spring 36 is selected to be greater than that due to the spring 15. At that time, the movable conductor 10 is allowed to slightly rise due to the above-mentioned clockwise rotation of the control lever 63. As a result, a distance between the fixed contact 9 (or 16) and the movable contact 11 (or 12) decreases a little from the state shown in FIGS. 1-4.

In the AUTO-position of the operation handle 50, the indication label 83 for indicating the AUTO-position of the circuit breaker can be observed through the opening 52 as shown in FIG. 9, which is a plane view seen from IX of FIG. 5. The off state under the AUTO-position is thus acknowledged by the operator. Since the transmission lever 34 is not actuated, the push rod 84 does not move and is projected out of the front cover 5a.

In the AUTO-position of the operation handle 50 as shown by FIG. 5, when the electromagnetic unit 200 is not excited, the limit switch 45 (FIG. 8) is actuated by receiving motion of the pusher plate 61, thereby making contact therein. When a voltage is applied to the terminal 42 (FIG. 1), the coil 26 is excited, and the movable iron core 30 is attracted by the fixed iron core 28. As the movable iron core 30 moves, the transmission lever 34 rotates counterclockwise against the force of the tension spring 36, thereby releasing the control lever 63. Therefore, the movable conductor 10 rises by expansion of the compression spring, and the movable contacts 11 and 12 make the contact with the fixed contacts 9 and 16, respectively. This state is shown by FIG. 8. In this state, a pair of the projections 31b (FIG. 8) of the holder 31 push the actuators 37a and 38a (FIG. 8), thereby actuating contacts in the auxiliary switches 37 and 38, respectively. At the time when the movable iron core 30 impacts upon the fixed iron core 28, shock is absorbed by the elastic member 29. In response to rotation of the transmission lever 34, the push bar 84, which is urged to move downward by the spring 86, goes down to follow the motion of the transmission lever 34. An upper end of the push bar 84 is thereby pulled into the hole 85a of the front cover 5a. Therefore, the state in which the movable contacts 11 and 12 make contact with the fixed contacts 9 and 16 can be visually confirmed by the operator.

In FIG. 8, when the voltage supplied to the terminal 42 (FIG. 1) is removed, the movable iron core 30 separates from the fixed iron core 28 by the force of the tension spring 36. Further, the control lever 63 is rotated counterclockwise by receiving torque of the transmission lever 34 which is biased by the tension spring 36. Since the force to rotate the control lever 63 is larger than the force due to the spring 15 acting on the movable conductor 10, one end 63a of the control lever 63 pushes the crossbar 14, thereby breaking contact between the fixed contacts 9 and 16 and the movable contacts 11 and 12, respectively. Thus, the circuit breaker returns to the state shown by FIG. 5. According to the above mentioned operation, opening/closing of contacts is carried out by the remote control (i.e., voltage is supplied or not) through repetition of the states shown by FIGS. 5 and 6 without any operation of the operation mechanism unit 300.

In the state shown in FIG. 6, current flows from the terminal 6 (FIG. 1) of the power-source side to the terminal 78 (FIG. 1) of the power-source side to the terminal 78 (FIG. 1) of the load side through the fixed conductor 8, the fixed contact 9, the movable contact 11, the movable conductor 10, the movable contact 12, the fixed contact 16, the fixed conductor 17, the first yoke 65 (FIG. 1), the bimetal 67 (FIG. 1), the flexible copper wire 77 (FIG. 1) and the coil 76 (FIG. 1), in this order.

Next, tripping operation from the state (remote-on) of FIG. 6 to the state (trip) of FIG. 7 is described. When an overcurrent flows through the circuit breaker under the state of FIG. 6, the bimetal 67 (FIG. 1) bends right-

ward and pushes the actuator 80 (FIG. 1). The trip bar 59 is thereby rotated counterclockwise against the force of the torsion spring (now shown), and the latch 57 is rotated clockwise against the force of the torsion spring (not shown). When the lever 56 is disengaged from the latch 57 by rotation of the latch 57, the roller 53 and the lever 56 are permitted to move leftward. Therefore, the pusher plate 61, which is pulled upward by the tension spring 62 (FIG. 1), pushes the roller 55 and the lever 56 aside and rises, thereby causing counterclockwise rotation of the control lever 63 against the force of the compression spring 15. Accordingly, the movable contacts 11 and 12 separate from the fixed contacts 9 and 16, respectively. The resultant state is shown in FIG. 7. In this state, a distance between the fixed contact 9 (or 16) and the movable contact 11 (or 12) is larger than that in the state of FIG. 5. As shown in FIG. 7, the operation handle 50 is positioned at an intermediate position after the trip operation, thereby informing the operator that the circuit breaker has tripped.

When the pusher plate 61 rises, the limit switch 45 (FIG. 8) is actuated and breaks its contact. Excitation of the coil 26 is thereby lost, and the ordinary opening operation is carried out as a result. That is, the movable iron core 30 separates from the fixed iron core 28, and the control lever 63 rotates to break contacts between the fixed contacts 9 and 16 and the movable contacts 11 and 12, respectively, via rotation of the transmission lever 34. As a result, the forces of both of the tension springs 62 and 36 are applied to the movable conductor 10. The movable contacts 11 and 12 separate from the fixed contacts 9 and 16 by extremely strong force against the force of the compression spring 15, respectively.

When a short-circuit current flows through the circuit breaker shown in FIG. 6, the coil 76 (FIG. 1) is excited and the plunger 71 (FIG. 1) is instantaneously attracted to the core 70 (FIG. 1). The trip bar 59 is thereby rotated counterclockwise against the force of the torsion spring (not shown). Thereafter, tripping operation is carried out in the same way as that caused by bending of the bimetal 67, thereby breaking contact of the circuit breaker. At the same time, as shown in FIG. 7, the rod 73 connected with the plunger 71 directly hits the holder 13, thereby separating the movable contacts 11 and 12 from the fixed contacts 9 and 16, respectively.

Breaking contact generates arcs between the movable contacts 11, 12 and the fixed contacts 9, 16, respectively. These arcs move between the movable conductor 10 and the fixed conductors 8 and 17, respectively. Further, the arcs move between a pair of arc runners 92, 93 (FIG. 1) and the fixed conductors 8, 17, respectively. The arcs are thereby divided and extinguished as a result. Hot gas generated in the arc extinguishing chambers 18A and 18B is exhausted out of the vents 20 through holes (not shown) of the exhaust sheets 18b and the exhaust passage 19.

When the operation handle 50 is pushed to the left to thereby put it in the OFF-position from the trip state (FIG. 7), the lever 56 pushes the roller 55 rightward. The roller 55 thereby comes into contact with the pusher plate 61, and the lever 56 is engaged with the latch 57. Resetting operation is thus completed.

When the operation handle 50 is put in the OFF-position or AUTO-position, the indication label 82 (OFF) or the indication label 83 (AUTO) is exposed through the opening 52 of the front cover 5a, respectively.

Therefore, the operator can visually confirm an "OFF" or "AUTO" state of the circuit breaker. Further, when the circuit breaker makes contact under the AUTO-position, the push bar 84 lowers to the predetermined position by the spring 86 to follow the motion of the transmission lever 34. The operator perceives a state of contact in the circuit breaker by the position of the upper end of the push rod 84.

In the description made above, making/breaking contact of the circuit breaker is carried out in response to the remote control. On the other hand, when it is desired to activate the circuit breaker manually, such as during inspection of the circuit breaker, manual operation of contact is possible by pushing the push rod 84 in the state (AUTO-OFF) of FIG. 5. When the push rod 84 is pushed down against the force of the tension spring 36, the transmission lever 34 is rotated counterclockwise, thereby resulting in the same state (FIG. 6) as that when the movable iron core 30 is attracted. That is, the movable conductor 10 and the crossbar 14 rise by the force of the compression spring 15 until the movable contact 11 and 12 make contact with the fixed contact 9 and 12, respectively. At the same time, the control lever 63 is rotated clockwise. Under the state of FIG. 6, when the finger is detached from the push rod 84, the transmission lever 34 returns to the state of FIG. 5 by the force of the tension spring 36. By the returning motion of the transmission lever 34, the push rod 84, the movable iron core 30 and the control lever 63 return to the state of FIG. 5.

Next, a second embodiment of the present invention is described with reference to FIGS. 10-16.

FIG. 10 is a cross-section view showing the remote-controlled circuit breaker with an operation handle 50 in its OFF-position and wherein a remote control command commands an off state. FIG. 11 is a plan view of the circuit breaker of FIG. 10 with its front cover 5a partially removed. FIG. 12 is an internal side view showing main parts of the circuit breaker with the operation handle 50 in its AUTO-position and wherein the remote control command commands an off state. FIG. 13 is an internal side view showing main parts of the circuit breaker with the operation handle 50 in the AUTO-position and wherein the remote control command commands an on state. FIG. 14 is an internal side view showing main parts of the circuit breaker in a trip state. FIG. 15 is a plan view from XV (FIG. 12) showing the operation handle 50. FIG. 18 is a plan view from XVI (FIG. 13) showing the operation handle 50. Corresponding parts and components to the first embodiment are shown by the same numerals and marks, and the description thereof made in the first embodiment similarly applies. Differences and features of this second embodiment from the first embodiment are as follows.

In FIG. 10, an on-indicator 87 for indicating the on state of the circuit breaker is rotatably held by the pin 51 and linked to the control lever 63 by means of a link lever 88. The link lever 88 is rotatably connected to the on-indicator 87 and the control lever 63 by a pair of pins 89a and 89b.

In the off state of the circuit breaker shown in FIGS. 10 and 11, the indication label 82 for indicating the off state is exposed through the opening 52 of the front cover 5a. The operator is thereby provided a visual indication of the off state of the circuit breaker.

In the AUTO (remote-controllable) state of the circuit breaker shown in FIGS. 12 and 15, the indication label 83 for indicating AUTO state is exposed through

the opening 52 of the front cover 5a. The operator thereby obtains a visual indication of the AUTO-and-off state of the circuit breaker. At that time, since the control lever 63 is not actuated, the on-indicator 87 does not move.

In the on state of the circuit breaker shown in FIG. 13, the link lever 88 is lowered in response to rotation of the control lever 63, and the on-indicator 87 is thereby rotated clockwise. Therefore, the on-indicator 87 is observed through the opening 52.

In the trip state of the circuit breaker shown in FIG. 14, since the operation handle 50 is positioned at its intermediate position, the operator can determine that the circuit breaker is in the trip state.

As mentioned above, the circuit breaker of this second embodiment is capable of indicating all states shown in the following Table 1.

TABLE 1

Position of the operation handle 50	State of contacts	Indication
OFF	off	OFF
AUTO	off	AUTO
AUTO	on	ON
Intermediate	trip	—

Next, a third embodiment of the present invention is described with reference to FIGS. 17-23.

FIG. 17 is cross-sectional view showing a remote-controlled circuit breaker with an operation handle 50 in its OFF-position and wherein a remote control command commands an off state. FIG. 18 is a plan view of the circuit breaker with its front cover 5a partially removed. FIG. 19 is a partially cross-sectional view of the circuit breaker taken on line XIX-XIX in FIG. 18. FIG. 20 is an internal side view showing main parts of the circuit breaker with the operation handle 50 in its AUTO-position and wherein the remote control commands an off state. FIG. 21 is an internal side view showing main parts of the circuit breaker with the operating handle 50 in the AUTO-position and wherein the remote control command commands an on state. FIG. 22 is an internal side view showing main parts of the circuit breaker in a trip state. FIG. 23 is an internal side view showing main parts of the circuit breaker in a manual state. Corresponding parts and components to the first embodiment are shown by the same numerals and marks, and the description thereof made in the first embodiment similarly applies. Differences and features of this third embodiment from the first embodiment are as follows.

In FIG. 19, a push rod 90 is slidably held in the vertical direction by a hole 91b of the magnet frame 25 and a hole 91a of the front cover 5a and is urged upwards by a spring 92. A lower end 90a of the push rod 90 abuts onto the transmission lever 34 which is in the upper position, and an upper end 90b projects out of the front casing 5a.

In the above-mentioned construction of the push rod 90, the operator can manually actuate the electromagnetic unit 200 even after installation of the circuit breaker, for example, to check the circuit. Such manual operation is carried out by pushing the push rod 90 down in the remote-off state with the operation handle 50 in the AUTO-position as shown in FIG. 20. When the push rod 90 is pushed down against the spring 92 in the state of FIG. 20, the transmission lever 34 is rotated counterclockwise against the spring 36 as shown in FIG. 23, thereby resulting in a state the same as that

when the movable iron core 30 is attracted to the fixed iron core 28. That is, the movable contacts 11 and 12 make contact with the fixed contacts 9 and 16 by the force of the compression spring 15, respectively, and the crossbar 14 rotates the control lever 63 clockwise. When the operator ceases pushing the push rod 90 in the manual-on state shown in FIG. 23, the push rod 90 returns to the former position (FIG. 20) by the spring 92. At the same time, the transmission lever 34 returns to its former position (FIG. 20) by the tension spring 36, and the control lever 63 is rotated counterclockwise. The movable contacts 11 and 12 thereby separate from the fixed contacts 9 and 16, respectively. Furthermore, the movable iron core 30 separates from the fixed iron core 28. Thus, the circuit breaker returns to the state of FIG. 20.

Although the invention has been particularly described in terms of preferred forms, it is understood that variations in the details of construction and the combination and arrangement of parts may be resorted to without departing from the spirit and the scope of the invention as hereinafter claimed.

What is claimed is:

1. A remote-controlled circuit breaker comprising;
 - a casing;
 - a fixed contact fixedly mounted to said casing;
 - a movable contact movably mounted to said casing to move in and out of contact with said fixed contact;
 - an electromagnetic unit comprising an electromagnetic coil and a fixed iron core which are fixedly mounted to said casing and a movable iron core movably mounted to said casing to be attracted to said fixed iron core;
 - a control lever which is pivotally mounted to said casing to move said movable contact into and out of contact with said fixed contact;
 - operation means, including an operation handle, for releasably holding said control lever, said operation means forming a toggle and holding said control lever in a position for moving said movable contact out of contact with said fixed contact when said operation handle is in a first position and releasing said control lever to allow a predetermined rotation thereof when said operation handle is in a second position;
 - an overcurrent tripping unit for causing said operation means and said control lever to actuate to move said movable contact out of contact with said fixed contact when a current greater than a predetermined value flows through said circuit breaker;
 - a transmission lever which is pivotally mounted to said casing to transmit a motion of said movable iron core to said control lever; and
 - a push rod movably mounted in said casing and having a first position in which said push rod projects out of said casing and a second position in which said push rod contacts said transmission lever.
2. A remote-controlled circuit breaker in accordance with claim 1, wherein
 - said first position of the operation handle is an off position of said circuit breaker, and said second position of the operation handle is a remote-controllable position of said circuit breaker.
3. A remote-controlled circuit breaker in accordance with claim 1 further comprising a spring for urging said push rod constantly into contact with said transmission lever.

13

- 4. A remote-controlled circuit breaker in accordance with claim 3, wherein said first position of the operation handle is an off position of said circuit breaker, and said second position of the operation handle is a remote-controllable position of said circuit breaker. 5
- 5. A remote-controlled circuit breaker in accordance with claim 1 further comprising a spring for urging said push rod constantly to project from said casing. 10
- 6. A remote-controlled circuit breaker in accordance with claim 5, wherein said first position of the operation handle is an off position of said circuit breaker, and said second position of the operation handle is a remote-controllable position of said circuit breaker. 15
- 7. A remote-controlled circuit breaker comprising:
 - a casing;
 - a fixed contact fixedly mounted to said casing;
 - a movable contact movably mounted to said casing to move in and out of contact with said fixed contact;
 - an electromagnetic unit comprising an electromagnetic coil and a fixed iron core which are fixedly mounted to said casing and a movable iron core movably mounted to said casing to be attracted to said fixed iron core; 20
 - a control lever which is pivotally mounted to said casing to actuate said movable contact into and out of contact with said fixed contact;
 - operation means, which includes an operation handle having a position indicator for indicating an off position of said circuit breaker and a remote-con-

14

- trollable position of said circuit breaker and forms a toggle for releasably holding said control lever, for holding said control lever in a position for moving said movable contact out of contact with said fixed contact at said off position of said operation handle and for releasing said control lever to allow a predetermined rotation thereof at said remote-controllable position of said operation handle;
- an overcurrent tripping unit for causing said operation means and said control lever to actuate to separate said movable contact from said fixed contact when a current greater than a predetermined value flows through said circuit breaker;
- a transmission lever which is pivotally mounted to said casing to transmit a motion of said movable iron core to said control lever;
- an indicator which moves in accordance with said control lever to provide a visual indication of whether said movable contact makes contact with said fixed contact or not; and
- a link lever for connecting said indicator with said control lever.
- 8. A remote-controlled circuit breaker in accordance with claim 7, wherein said indicator and said operation handle are pivotally mounted to said casing around a common pin, and wherein said indicator covers said position indicator with an on-indication in a state in which said movable contact makes contact with said fixed contact.

* * * * *

35

40

45

50

55

60

65